



GREEN ELECTRONICS

Distributed by:



www.texim-europe.com

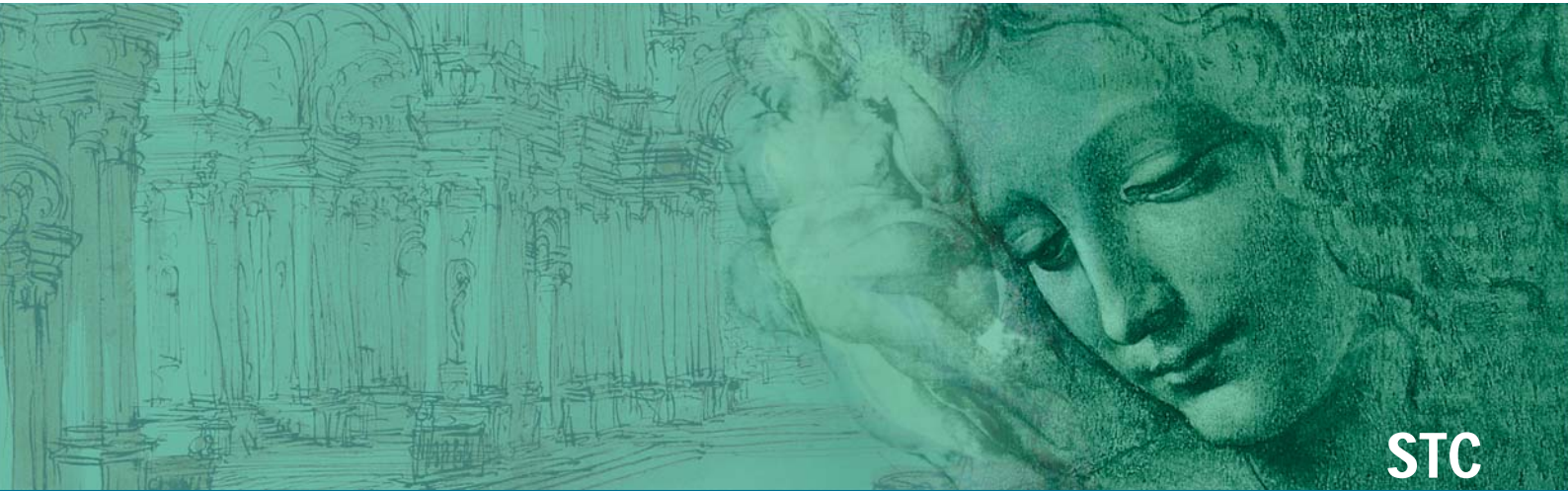

STC

Supports



ISO
9001



ISO
14001



BS OHSAS
18001:2007



SAURO®

ELECTRONIC CONNECTORS

by the law

PCB SUPPORTS

English Extruded and Modular Supports

The recent development of electronic equipment used in industrial automation requires a PCB to be mounted in a safe way according to the updated legislative regulations.

In order to comply with these requirements SAURO offers a safe and rational solution: self-extinguishing plastic PCB Supports.

Two **Support** types are available: **Extruded Supports** (STC072 and STC107 Series) and **Modular Supports** (SMC072 and SMC107 Series). Both allow the PCB to be mounted on DIN EN 50022, DIN EN 50035, DIN EN 50045 rails.

Extruded Supports are composed of a base element, obtained from an **extruded bar, cut to standard or custom length**, and equipped with **accessories for rail mounting**. An accessory for Mounting on the Wall is also available.

Modular Supports are composed of a **reduced number of moulded plastic components that can be combined together** to obtain **Supports for a variety of PCB lengths**.

Two dimensional Series of Supports are available, respectively for **72 mm (2.835 in) wide boards** (STC072 and SMC072 Series) and for **107.5 mm (4.232 in) wide boards** (STC107 and SMC107 Series).

With the use of **adapters, 100 mm (3.937 in) and 68 mm (2.677 in) wide PCBs** can be mounted respectively on STC107 and STC072 Series Supports.

It is also possible to mount a **transparent plastic Protection Cover** that limits the access to the electronic circuit (available only for STC107 Series).

The typical configuration is composed of two Lateral Elements, a Central Body and one or more Hooks for mounting on DIN Rail.

With short Supports for lightweight boards, Lateral Elements with right-hand and left-hand Hooks can be used, therefore it is not necessary to use Hooks for mounting on DIN Rail.

The Central Body can be cut from an Extruded bar or built from a number of Base Elements (Modular), depending on the Support length desired, as explained in the tables on the following pages.

The assembling sequence is as follows:

- assemble all the support components except for one of the Lateral Elements;
- insert the PCB from the open end;
- close the support with the remaining Lateral Element;
- snap mount onto the DIN rail;
- apply the Protection Cover, if needed.

In order to remove the Support from the omega-shaped DIN rail, lever on the back hook.

Extruded Supports can be supplied, with a surcharge, with one Lateral Element already assembled; this option must be clearly requested.

Italiano Supporti estrusi e modulari

Il recente sviluppo degli apparati elettronici impiegati nell'automazione industriale richiede di poter appoggiare i circuiti elettronici su scheda in modo sicuro, secondo le più aggiornate prescrizioni legislative.

SAURO, a questo scopo, propone una soluzione sicura e razionale: i Supporti Portaschede in materiale plastico autoestinguente.

I **Supporti** sono realizzati in due tipologie costruttive: **Supporti Estrusi** (Serie STC072 e STC107) e **Supporti Modulari** (Serie SMC072 e SMC107), che consentono di montare delle schede elettroniche su guide DIN EN 50022, DIN EN 50035, DIN EN 50045.

I **Supporti Estrusi** sono composti da un elemento base, ricavato da una **barra estrusa, tagliato a misura standard o su richiesta**, corredato di **accessori per il montaggio**. E' disponibile un accessorio particolare per consentire il fissaggio a parete.

I **Supporti Modulari** sono composti da un **numero ridotto di particolari plastici stampati, componibili ad incastro** per ottenere dei **Supporti Portaschede di varia lunghezza**.

Sono disponibili due Serie dimensionali di Supporti, rispettivamente per **schede da 72 mm (2.825 in) di larghezza** (Serie STC072 e SMC072) e per **schede da 107,5 mm (4.232 in) di larghezza** (Serie STC107 e SMC107).

Con gli **adattatori** è possibile utilizzare le Serie STC107 e STC072 per alloggiare rispettivamente **schede con larghezza 100 mm e 68 mm**.

E' possibile montare una **Copertura di Protezione in materiale plastico trasparente** al fine di limitare l'accessibilità al circuito elettronico (solo Serie STC107).

La configurazione tipica è composta da due Testate Laterali, dal Corpo Centrale e da uno o più Agganci per Guida DIN.

Con i Supporti corti per schede di peso modesto si possono usare le Testate con Aggancio Destra e Sinistra, evitando perciò l'impiego dell'Aggancio per Guida DIN.

Il Corpo Centrale può essere il Profilo tagliato a Misura (Estruso) oppure un certo numero di Elementi Base (Modulare) composti, come spiegato nelle tabelle alle pagine successive, secondo la lunghezza da ottenere.

Il montaggio avviene secondo la seguente sequenza:

- montaggio di tutti gli elementi del supporto tranne una delle testate;
- inserimento della scheda dall'estremità aperta;
- chiusura con la testata libera;
- aggancio a scatto sulla guida DIN;
- montaggio dell'eventuale protezione.

Per smontare il Supporto dalle guide DIN a omega è sufficiente far leva sul gancio sporgente dal retro.

I Supporti Estrusi possono essere forniti, con sovrapprezzo, anche con una delle testate già assemblata; questa opzione deve essere richiesta in modo esplicito.

Deutsch Strangprofile und modulare Leiterplattenmodule

Die jüngste Entwicklung elektronischer Geräte in der industriellen Automation erfordert, dass die Leiterplatten auf sichere Art und nach den neusten gesetzlichen Vorschriften platziert werden können

SAURO schlägt zu diesem Zweck eine sichere und zweckmäßige Lösung vor: Leiterplattenmodule in selbstverlöschendem Plastikmaterial.

Die **Module** sind in 2 Bauarten aufgeteilt: **Strangprofile** (Serie STC072 und STC107) und **modulare Module** (Serie SMC072 und SMC107), die es ermöglichen, Leiterplatten auf DIN EN 50022, DIN EN 50035, DIN EN 50045 Schienen zu montieren.

Die **Strangprofile** bestehen aus einem Baseelement, das aus einer **Extrusionsstange gefertigt und nach Standard- oder kundenspezifischem Maß zugeschnitten wird**, ausgestattet mit **Zubehör für die Montage**. Es ist außerdem ein spezielles Zubehör zur Wand-Fixierung erhältlich.

Die **modularen Module** bestehen aus einer geringen **Anzahl Plastikelemente, welche kombinierbar sind, um Leiterplattenmodule unterschiedlicher Art zu erhalten**.

Es sind zwei verschiedene dimensionale Serien von Modulen erhältlich, für **Leiterplatten von 72 mm** (Serie STC072 und SMC072) und für **Leiterplatten von 107,5 mm** (Serie STC107 und SMC107) **Breite**.

Mit den **Adaptern** ist es möglich, die Serie STC107 und STC072 zu verwenden, für Leiterplatten mit einer **Breite von 100 mm und 68 mm**.

Es ist möglich, eine **transparente Plastikschutzabdeckung aufzubringen**, um die Zugänglichkeit zum Stromkreis einzuschränken (nur Serie STC107).

Die typische Darstellung besteht aus 2 Seitenelementen, dem mittleren Teil, und einem oder mehreren Fußelementen für DIN Schienen.

Bei kurzen Modulen für leichtgewichtige Leiterplatten, können die linken und rechten Seitenelemente mit Anrastung verwendet werden, ohne die Fußelemente für DIN Schienen benutzen zu müssen.

Der mittlere Teil kann das nach Maß zugeschnittene Profil (Strangprofil) oder eine bestimmte Anzahl kombinierter Baseelemente (modular) sein, je nach gewünschter Länge, wie auf den Tabellen der folgenden Seiten erklärt wird.

Die Reihenfolge der Montage ist wie folgt:

- Montage aller Modulelemente, außer einem Seitenelement;
- Einfügen der Leiterplatte von der offenen Seite her;
- Schließung mit dem anderen Seitenelement;
- Schnapp-Anrastung auf der DIN Schiene;
- Montage der eventuellen Schutzabdeckung.

Um den Halter aus der Omega-förmigen DIN Schiene abzumontieren, genügt es, auf die hintere Anrastung zu drücken.

Die Strangprofile können, zu einem Aufpreis, auch mit einem schon montierten Seitenelement geliefert werden; diese Option muss ausdrücklich verlangt werden.

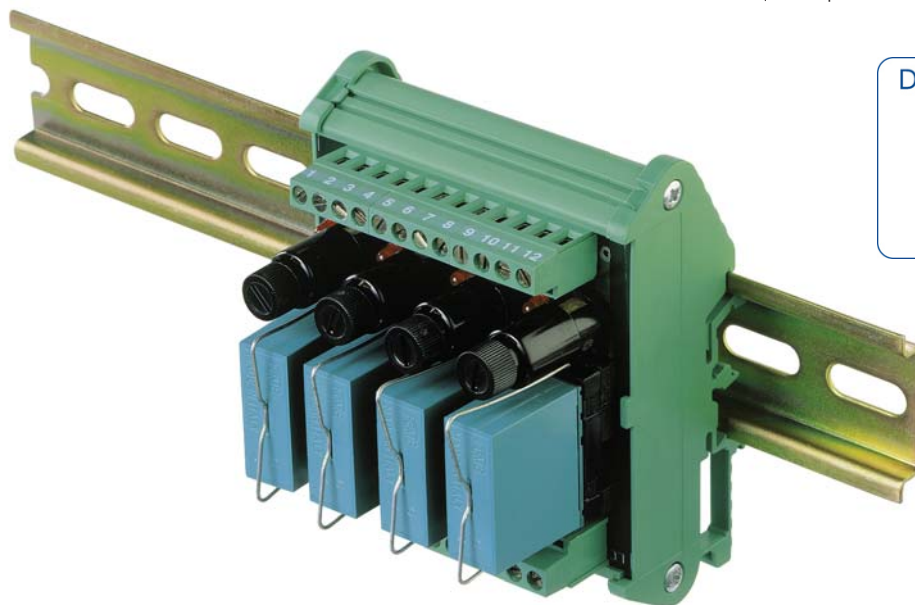

Distributed by:



www.texim-europe.com

Français Supports Extrudés et Modulaires

Le développement récent de l'utilisation d'appareils électroniques au sein des équipements automatiques industriels implique que les C.I. utilisés soient fixés d'une manière sûre et conforme aux législations actuelles.

Afin de répondre à ces exigences, SAURO vous propose une solution sûre et rationnelle : les Supports pour C.I. en plastique auto-extinguible.

Ces **Supports** sont divisés en deux catégories : les **Supports Extrudés** (Séries STC072 et STC107) et les **Supports Modulaires** (Séries SMC072 et SMC107), qui permettent de monter les C.I. sur des rails DIN EN 50022, DIN EN 50035 et DIN EN 50045.

Les **Supports Extrudés** se composent d'une embase extrudée, **disponible en longueur standard ou sur mesure**, et sont équipés d'**accessoires pour le montage sur rail**. Un accessoire particulier est également disponible en cas de montage mural.

Le **Supports Modulaires** se composent eux de **pièces en plastique moulée**, qui peuvent être assemblées afin d'obtenir des **Supports pour C.I. de différentes longueurs**.

Deux Classes Dimensionnelles de Supports sont disponibles afin d'être utilisées avec les **C.I. de 72 mm (2.825 in) de large** (Séries STC072 et SMC072) ou de **107.5mm (4.232 in) de large** (Séries STC107 et SMC107). Grâce à l'utilisation d'**adaptateurs**, il est possible d'utiliser les Séries STC107 et STC072 afin de monter des C.I. de largeur **100 et 68 mm**.

Il est également possible de fixer un **Couvercle de Protection en plastique transparent** afin de limiter l'accessibilité au circuit électronique (uniquement sur la Série STC107).

En règle générale le support est constitué de Deux Eléments Latéraux, d'une Embase Centrale et d'un ou plusieurs Pieds pour le montage sur Rail DIN.

Avec les Supports courts pour C.I. légers, il est possible d'utiliser des Eléments Latéraux déjà pourvus de Pieds (à Droite et à Gauche) permettant la fixation du C.I. sans avoir recours aux Attaches pour le montage sur Rail DIN.

L'Embase Centrale peut être conçue sur Mesure (modèle Extrudé) ou bien composée d'Eléments de Base à assembler (modèle Modulaire) selon la longueur désirée, comme illustré sur les pages suivantes.

Le montage s'effectue comme suit :

- assemblage de tous les Eléments du Support à part l'un d'eux ;
- insertion du C.I. par l'extrémité ouverte ;
- fermeture du Support avec l'Elément restant ;
- accrochage sur le rail DIN ;
- montage de l'éventuel Couvercle de protection.

Faire lever sur le pied ressortant à l'arrière du Support pour le démonter du Rail DIN.

Les Supports Extrudés peuvent également être fournis avec un des Eléments Latéraux pré-assemblé, sur demande du client et moyennant un surcoût.

Español Soportes extruidos y modulares

La reciente evolución de los aparados electrónicos en la automatización industrial pide que se pueda poner a los circuitos electrónicos sobre la placa con seguridad, haciendo referencia a las últimas prescripciones legislativas.

Por eso Sauro propone una solución segura y racional: los soportes que contienen las placas son de material plástico autoextinguible.

Los **soportes** están contruidos de dos formas: **Soportes extruidos** (serie STC072 y STC107) y **Soportes modulares** (serie SMC072 y SMC107) que permiten de montar las placas electrónicas sobre guías DIN EN 50022, DIN EN 50035, DIN EN 50045.

Los **Soportes Extruidos** están compuestos de un elemento base, obtenido de una **barra extruida, cortada de una medida estándar o personalizada** y equipado de **accesorios para el montaje**. Está disponible también un accesorio particular que permite la fijación a la pared.

Los **Soportes Modulares** están compuestos de **algunas piezas plásticas especiales a partir de muelles**, que pueden ir encajándose para que se pueda obtener **portaplacas de varias longitudes**.

Están disponibles dos tipos de dimensiones de soportes: para **placas desde 72 mm (2.825 in)** (serie STC072 y SMC072) y para **placas desde 107,5 mm (4.232 in)** (serie STC107 y SMC107) de anchura.

Con los **adaptadores** es posible utilizar la serie STC107 y STC072 para alojar placas con anchura **100 mm y 68 mm**.

También es posible montar una **cobertura de protección en material plástico transparente** para limitar el acceso al circuito electrónico (sólo serie STC107).

La configuración típica está compuesta por dos elementos laterales, por una parte central y por uno o más enganches por guía DIN.

Con soportes cortos, para placas de peso modesto se pueden utilizar elementos laterales con enganches derecha y izquierda evitando la utilización del enganche para la guía DIN.

La parte central puede ser el perfil cortado a medida (extruido) o otros componiendo diferentes elementos (modular), como explicaremos en las páginas siguientes a través de tablas; según la longitud que se debe obtener.

El montaje se desarrolla en esta secuencia:

- montaje de todos los elementos del soporte menos uno de los extremos laterales;
- introducción de la placa desde la extremidad abierta;
- cierre con el elemento lateral libre;
- enganche encajado sobre guía DIN;
- montaje de la protección (optional).

Para desmontar el soporte desde guía DIN hasta el tipo omega será suficiente apretar el enganche especialmente visible en la parte de atrás.

Los soportes extruidos pueden ser entregados con un sobrepeso, también con uno de los dos elementos laterales ensablados; esta opción debe ser pedida de manera explícita.

Chinese 挤压型支座与组合型支座

鉴于工业自动化领域不断更新的技术规范要求，电子设备的发展趋势需要将PCB放置于更安全的工业环境中。

为了符合这些规范要求，SAURO提供了一个安全且理性的解决方案：自熄灭式塑料制成的PCB支座。

有两种类型的支座：挤压型（STC072系列和STC107系列）和组合型（SMC072系列和SMC107系列），这两种支座均可放置于DIN EN 50022、DIN EN 50035和DIN EN 50045导轨上。

挤压型支座由一块挤压型材按标准长度或客户定制的长度切割而成，且提供封装用附件，也可提供壁挂用附件。

组合型支座由几个塑料模件相互组合而成，适用于各种长度的PCB。

可提供两大尺寸规格，分别适用于宽度为72mm（STC072系列和SMC072系列）的线路板和宽度为107.5mm（STC107系列和SMC107系列）的线路板。

若使用适配件，则可以将宽度为100mm和68mm的PCB分别放置于STC107系列和STC072系列支座。

还可使用一个透明的保护罩，这样可以更好地保护印刷电路板（只适用于STC107系列）。

典型配置包括两个侧面组件，一个主体部件以及一个或多个安装脚，以便安装在DIN导轨上。

要固定轻量级的支座，可使用带导轨安装脚的侧面组件，无需使用额外的安装脚。

主体部件由一块挤压型材切割而成，或由一些基座组件（可组合式模件）构成。这都取决于所需的支座长度，可参考以下各页列表格。

装配的顺序如下：

- 装配除一个侧面组件以外的其余部件；
- 将PCB从开口处嵌入；
- 用剩余的那个侧面组件封闭支座；
- 将支座安装在DIN导轨上；
- 视具体情况，可加装保护罩。

要从omega形状DIN导轨上卸载支座，只需抬起后侧的安装脚即可卸载。

可提供已装配有一个侧面组件的挤压型支座，价格会有一些上浮；这一配置须由客户明确提出。

Application sample

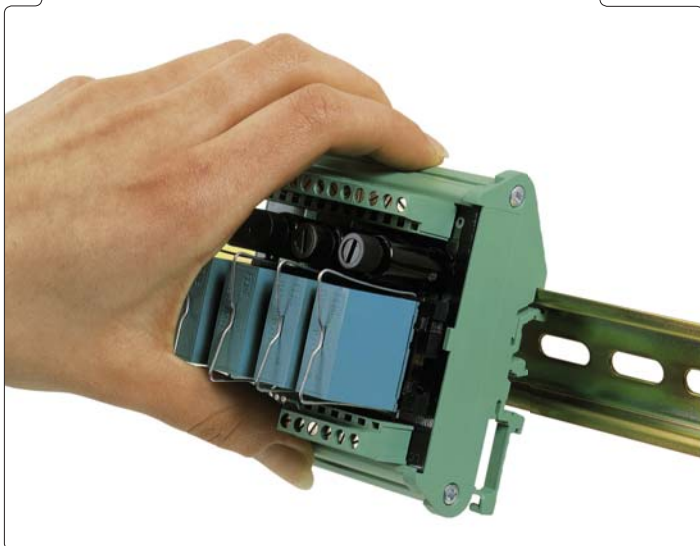

Application sample

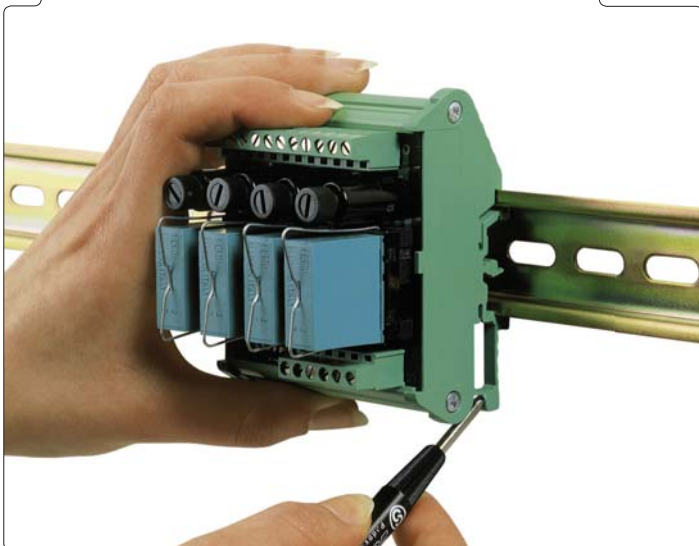

Distributed by:



STC072

Extruded Supports



Width of PCB:
68 mm - 72 mm (2.677 in - 2.835 in)



Support Type:
EXTRUDED



Standard Colour:
GREEN



Thickness of PCB:
1.6 ÷ 2.8 mm (.063 ÷ .110 in)



Material:
PA6.6 (UL94-V0) and PVC (UL94-V1)



STC072



Extruded Supports for 72 mm (2.835 in)

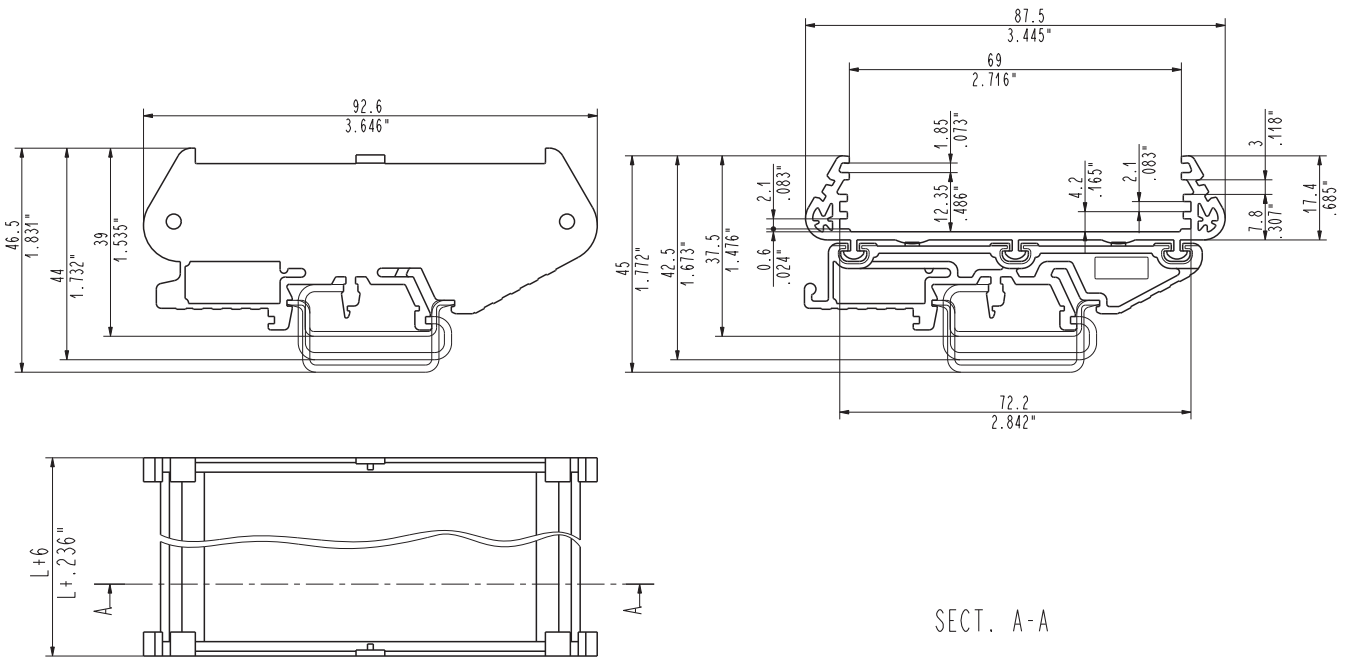

STC Parts

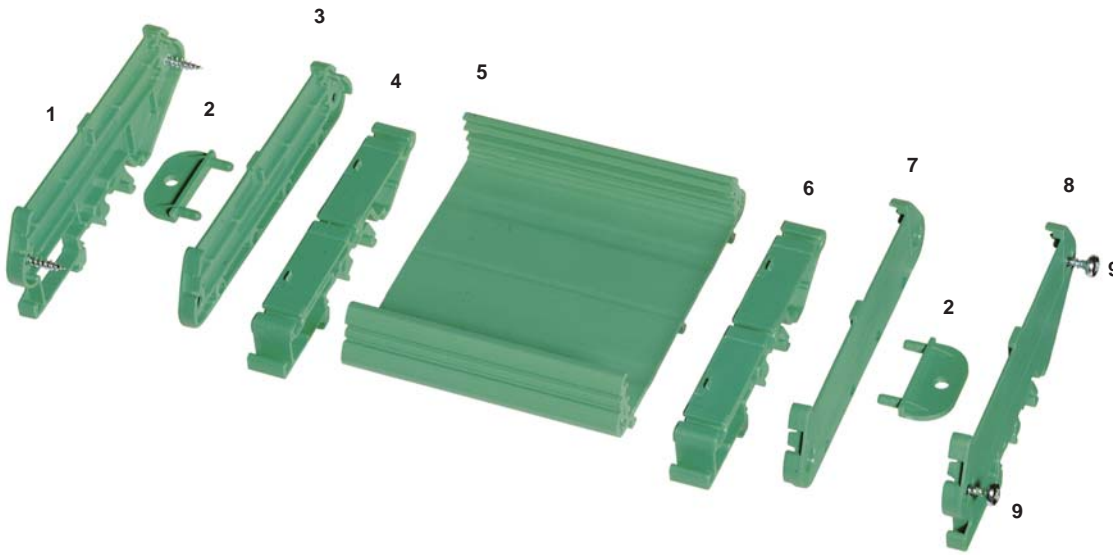

- 1 STC072TSX0
- 2 STC000F000
- 3 STC072T000
- 4 STC072P011
- 5 STC072S_ _ _
- STC0722000
- STC072L_ _ _
- 6 STC072P011
- 7 STC072T000
- 8 STC072TDX0
- 9 STC000V015

Custom Size Cut Extruded Profile

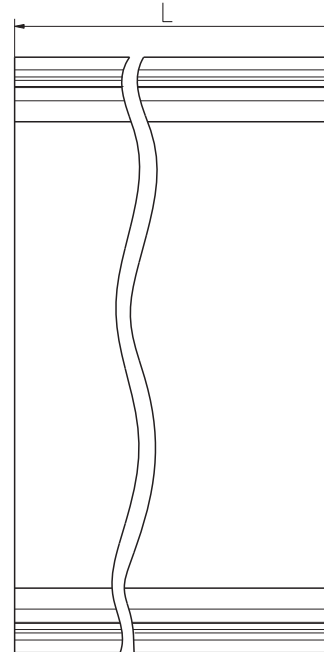
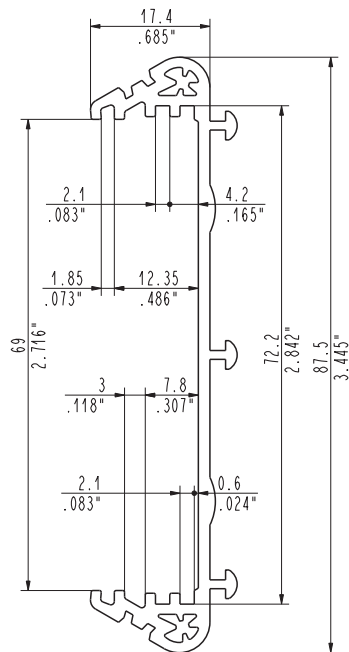

STC072S_ _ _
 STC0722000
 STC072L_ _ _

Distributed by:



STC072S_ _ _ / STC0722000 / STC072L_ _ _

Custom Sized Cut Profile

For a Custom Sized Cut Profile, the length of the Central Body must be equal to the length of the PCB minus 3.5 mm (.138 inch). It's advised to round off the figure to the higher whole number.

The length of the support, including the Lateral Elements, is equal to the length of the Profile plus 6 mm (.236 inch).

Cut Profile sizes L		Part-Number	Pcs / pack	For PCB		Length of support	
(mm)	(in)			(mm)	(in)	(mm)	(in)
16,50	.650	STC072S016	50	20,00	.787	22,50	.886
27,75	1.093	STC072S028	50	31,25	1.230	33,75	1.329
39,00	1.535	STC072S039	50	42,50	1.673	45,00	1.772
50,25	1.978	STC072S050	50	53,75	2.116	56,25	2.215
61,50	2.421	STC072S061	50	65,00	2.559	67,50	2.657
72,75	2.864	STC072S073	50	76,25	3.002	78,75	3.100
84,00	3.307	STC072S084	50	87,50	3.445	90,00	3.543
95,25	3.750	STC072S095	50	98,75	3.888	101,25	3.986
106,50	4.193	STC072S106	50	110,00	4.331	112,50	4.429
117,75	4.636	STC072S118	50	121,25	4.774	123,75	4.872
129,00	5.079	STC072S129	50	132,50	5.217	135,00	5.315
140,25	5.522	STC072S140	50	143,75	5.659	146,25	5.758
151,50	5.965	STC072S151	50	155,00	6.102	157,50	6.201
162,75	6.407	STC072S163	50	166,25	6.545	168,75	6.644
174,00	6.850	STC072S174	50	177,50	6.988	180,00	7.087
Profile for PCB with L = 2 m (78.740 in)		STC0722000	10	-----	-----	-----	-----
Custom	Custom	STC072L_ _ _	100	L + 3,5	L +.137	L + 6	L +.236

Extruded Supports

Lateral Element with Left Rail Hook

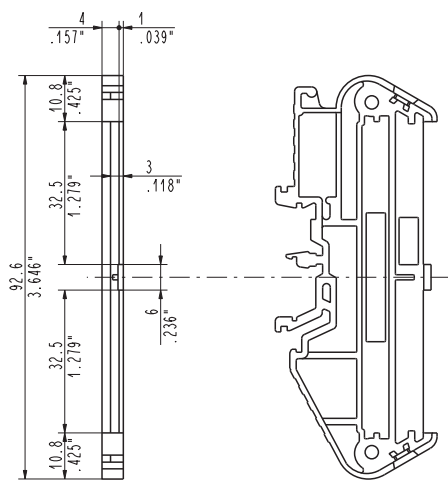

STC072TSX0

Lateral Element with Right Rail Hook

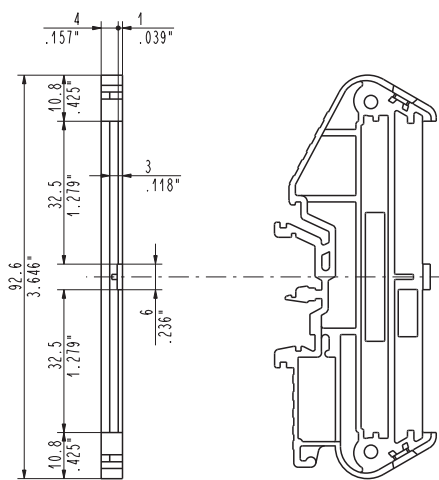

STC072TDX0

STC072TSX0 / STC072TDX0

Lateral Elements with Left and Right Rail Hook

Lateral Elements with Left and Right Rail Hook can be used to hook the Extruded Profile to the DIN rails to hold PCB Supports that are quite short and quite lightweight. Alternatively, it's possible to use 2 Lateral Elements Without Hooks by placing the required number of DIN Rail Hooks directly under the Extruded Profile.

To fasten each Lateral Element to the Extruded Profile, 2 Screws must be used.

For customer convenience, the Support can be supplied with one Lateral Element already assembled. This option, if desired, must be clearly requested.

Distributed by:



www.texim-europe.com

Description	Part-Number	Pcs / pack
Left Lateral Element with Rail Hook	STC072TSX0	50
Right Lateral Element with Rail Hook	STC072TDX0	50
Head Without Rail Hook	STC072T000	100
DIN Rail Hook	STC072P011	50
Screw for Head Fastening	STC000V015	100
Screw for Head Fastening	STC000V025	100

Lateral Element without Rail Hook

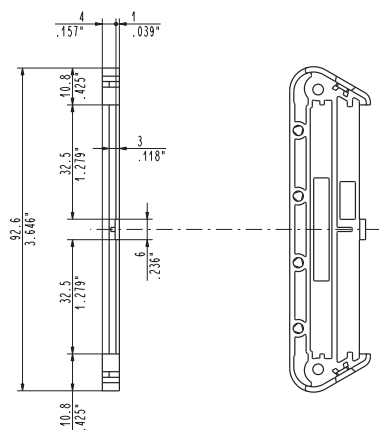

STC072T000

DIN Rail Hook

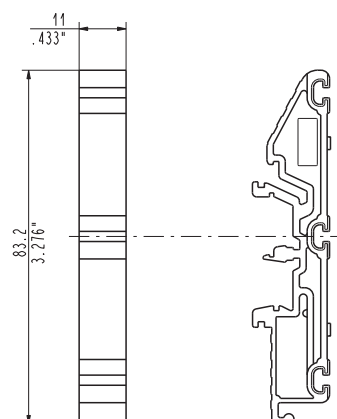

STC072P011

Bracket for Mounting on the Wall

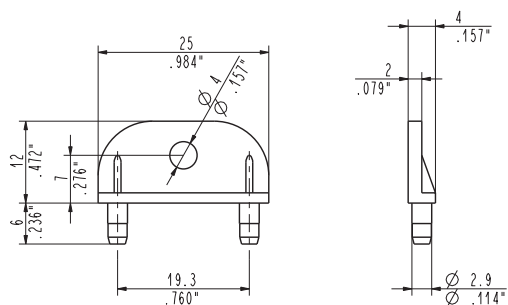

STC000F000

Size Adapter for 2.677 in (68 mm) PCB

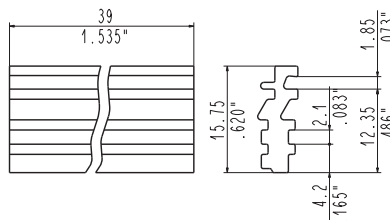

STC072A026

STC000F000

UL 94 V-0 Self-Extinguishing Polyamide PA 6.6

A **Bracket for Mounting on the Wall** can be used to fasten the PCB Support to a flat surface rather than hooking it to a DIN rail. The **Bracket** is suitable only for **Lateral Elements Without a Rail Hook**. One **Bracket** for each Lateral Element is needed and it is snapped on. The **Bracket for Mounting on the Wall** can be used with both **STC072** and **STC107** Series.

STC072A026

The **Adapter for 68 mm (2.677 in) PCBs** is necessary when mounting 68 mm (2.677 in) wide boards on the **STC072** Series Supports. It must be inserted lengthwise into the Profile, in the desired side and it doesn't need fastening. The board will be offset in relation to the centerline of the profile. This position must be taken into consideration if the Protection Cover is used. The **Adapter for 2.677 in (68 mm) PCBs** is available in **1.024 in (26 mm) standard length**. It must be used in a quantity that does not exceed the correspondent length of the Profile.

Distributed by:



Description	Part-Number	Pcs / pack
Bracket for Mounting on the Wall	STC000F000	100
Size of STD Adapter for 68 mm (2.677 in) Boards	STC072A026	50

In the following table some indicative examples of configuration are shown, as might occur in some practical applications.

Example	Extruded Profile	Left Lat. Element with Rail Hook	Right Lat. Element with Rail Hook	Head Without Rail Hook	DIN Rail Hook	Screw for Head Fastening	Bracket for Mounting on the Wall
	STC072 _____	STC072TSX0	STC072TDX0	STC072T000	STC072P011	STC000V015	STC000F000
Lightweight	1	1	1			4	
Medium Weight	1			2	1	4	
Medium-Heavyweight	1			2	2	4	
Heavyweight	1			2	3	4	
Support to be fastened on a flat surface	1			2		4	2 ÷ 4

Distributed by:



www.texim-europe.com

STC 107

Extruded Supports



Width of PCB:
100 mm - 107.5 mm (3.937 in - 4.232 in)



Support Type:
EXTRUDED



Standard Colour:
GREEN



Thickness of PCB:
1.6 ÷ 2.8 mm (.063 ÷ .110 in)



Material:
PA6.6 (UL94-V0) and PVC (UL94-V1)

STC107

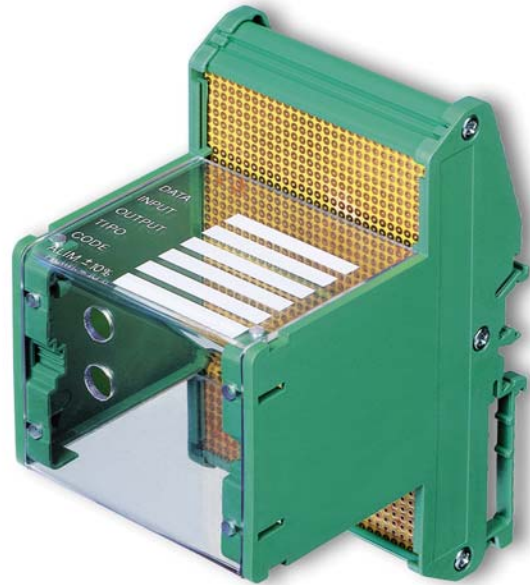

Extruded Supports for Boards 107.5 mm (4.232 in) Wide

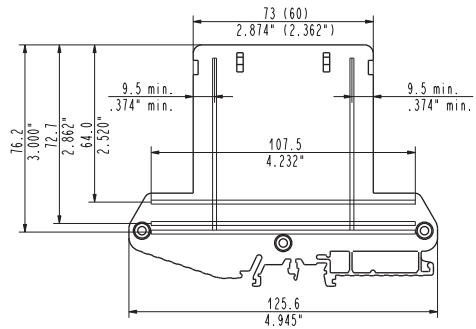
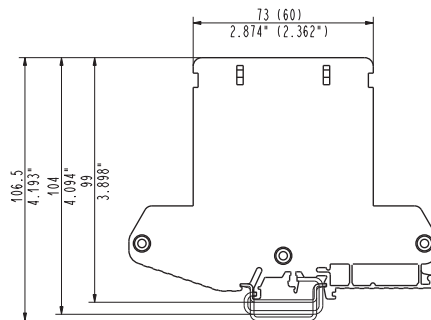
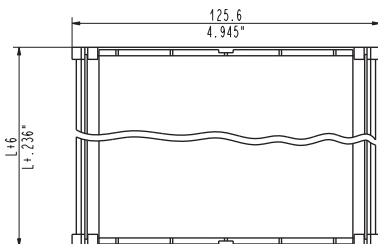
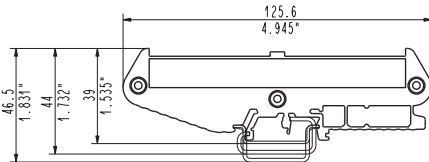
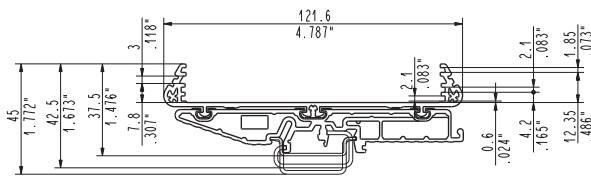

STC PARTS

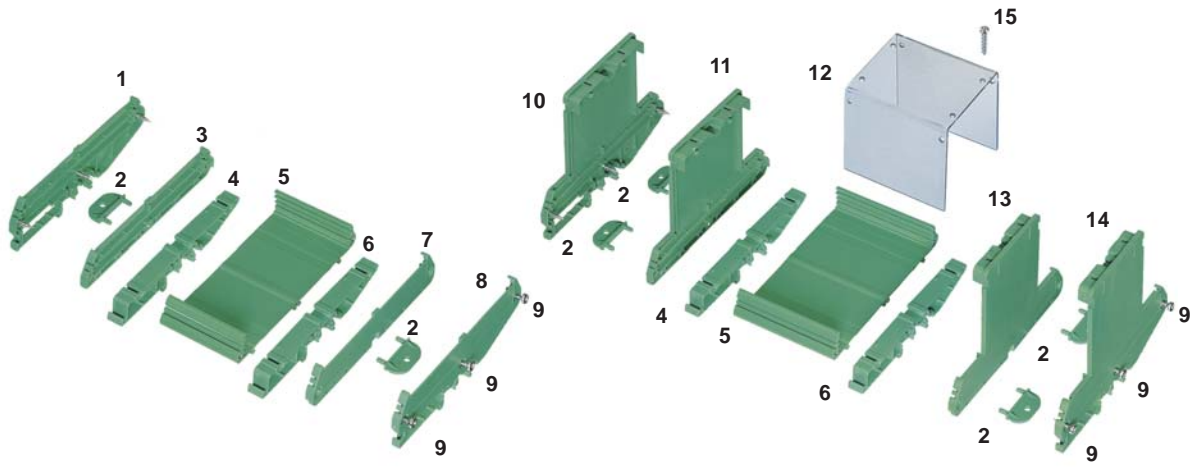

- 1 STC107TSX0
- 2 STC000F000
- 3 STC107T000
- 4 STC107P011
- 5 STC107S_ _ _
- STC1072000
- STC107L_ _ _
- 6 STC107P011
- 7 STC107T000
- 8 STC107TDX0
- 9 STC000V015
- 10 STC107TS73
- 11 STC107T073
- 12 STC107C_ _ _
- STC107D_ _ _
- 13 STC107T060
- 14 STC107TD60
- 15 STC000VC15

Custom sized Cut Extruded Profile

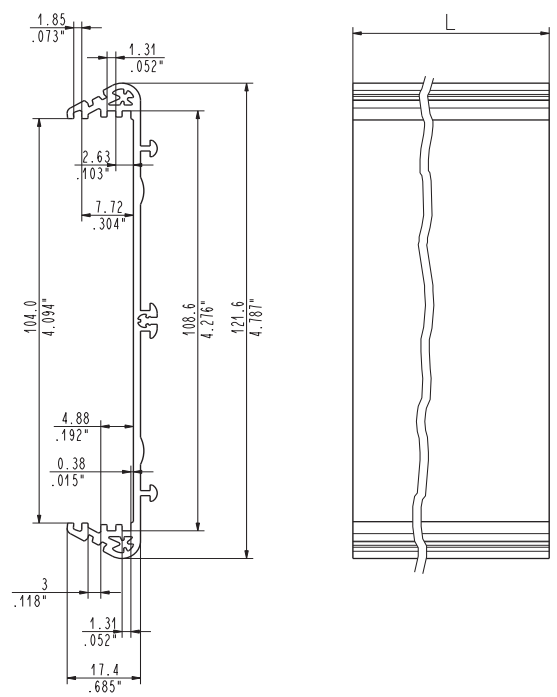

STC107S_ _ _
STC1072000
STC107L_ _ _

Distributed by:

www.texim-europe.com

STC107S_ _ _ / STC1072000 / STC107L_ _ _

Custom sized Cut Extruded Profile

For a Custom Sized Cut Profile, the length of the Central Body must be equal to the length of the PCB minus 3.5 mm (.138 inch). It's advised to round off the figure to the higher whole number.

The length of the support, including the Lateral Elements, is equal to the length of the Profile plus 6 mm (.236 inch).

Cut Profile sizes L		Part-Number	Pcs / pack	For PCB		Support Length	
(mm)	(in)			(mm)	(in)	(mm)	(in)
35,00	1.378	STC107S035	50	38.50	1.516	41.00	1.614
51,50	2.028	STC107S051	50	55.00	2.165	57.50	2.264
70,00	2.756	STC107S070	50	73.50	2.894	76.00	2.992
86,50	3.406	STC107S086	50	90.00	3.543	92.50	3.642
105,00	4.134	STC107S105	50	108.50	4.272	111.00	4.370
121,50	4.783	STC107S121	50	125.00	4.921	127.50	5.020
140,00	5.512	STC107S140	40	143.50	5.650	146.00	5.748
156,50	6.161	STC107S156	50	160.00	6.299	162.50	6.398
175,00	6.890	STC107S175	40	178.50	7.026	181.00	7.126
191,50	7.539	STC107S191	50	195.00	7.677	197.50	7.776
210,00	8.268	STC107S210	50	213.50	8.406	216.00	8.504
226,50	8.898	STC107S226	50	230.00	9.055	232.50	9.154
245,00	9.646	STC107S245	50	248.50	9.783	251.00	9.882
261,50	10.295	STC107S261	50	265.00	10.433	267.50	10.531
280,00	11.024	STC107S280	50	283.50	11.161	286.50	11.260
Profile for PCB with L = 2 m (78.740 in)		STC1072000	10	-----	-----	-----	-----
Custom		STC107L_ _ _	100	L + 3.5	L + .137	L + 6	L + .236

Extruded Supports

Left Lateral Element with Rail Hook

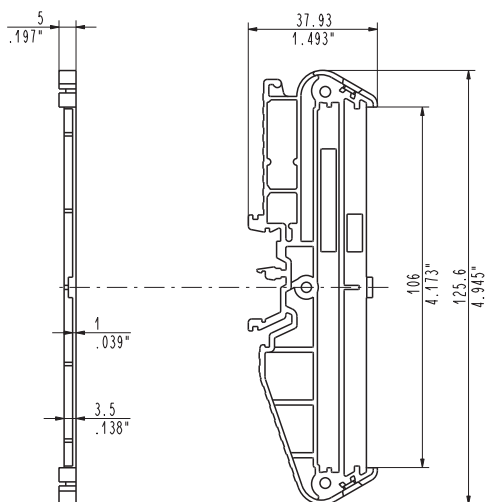

STC107TSX0

Right Lateral Element with Rail Hook

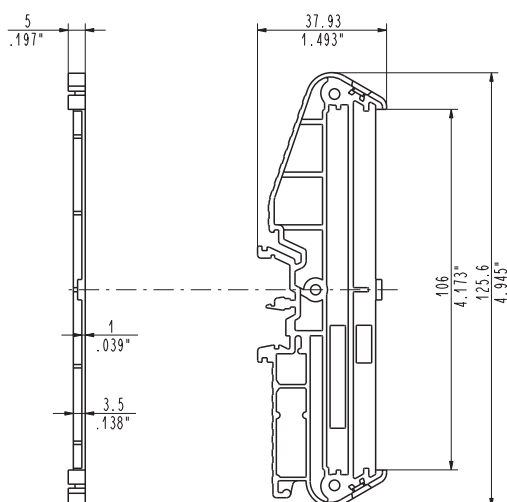

STC107TDX0

STC107TSX0 / STC107TD0

Lateral Elements with Left and Right Rail Hook

Lateral Elements with Left and Right Rail Hook can be used to hook the **Extruded Profile** to the DIN rails to hold PCB Supports that are quite short and quite lightweight. Alternatively, it's possible to use 2 **Lateral Elements Without Hooks** by placing the required number of **DIN Rail Hooks** directly under the Extruded Profile.

To fasten each Lateral Element to the Extruded Profile, 3 **Screws** must be used.

For customer convenience, the Support can be supplied with one Lateral Element already assembled. This option, if desired, must be clearly requested.

Description	Part-Number	Pcs / pack
Left Lateral Element with Rail Hook	STC107TSX0	50
Right Lateral Element with Rail Hook	STC107TDX0	50
Head Without Rail Hook	STC107T000	100
DIN Rail Hook	STC107P011	100
Screw for Head Fastening (L=15mm)	STC000V015	100
Screw for Head Fastening (L=15mm)	STC000VC15	100
Screw for Head Fastening (L=15mm)	STC000V025	100

Head Without Rail Hook

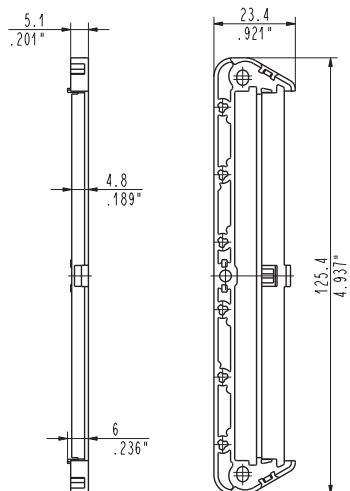

STC107T000

DIN Rail Hook

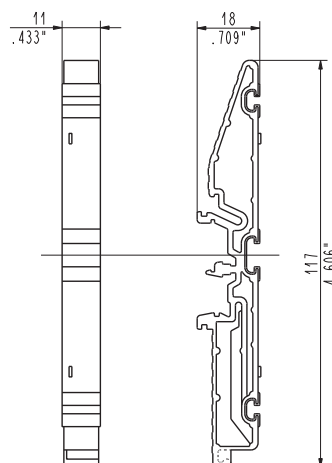

STC107P011

Left High Lateral Element with Rail Hook

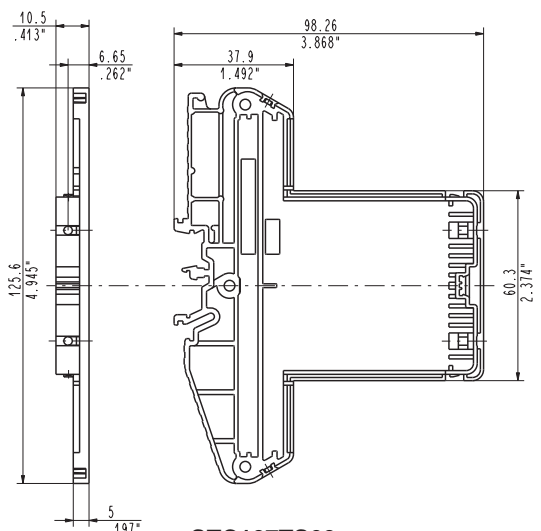

STC107TS60

Left High Lateral Element with Rail Hook

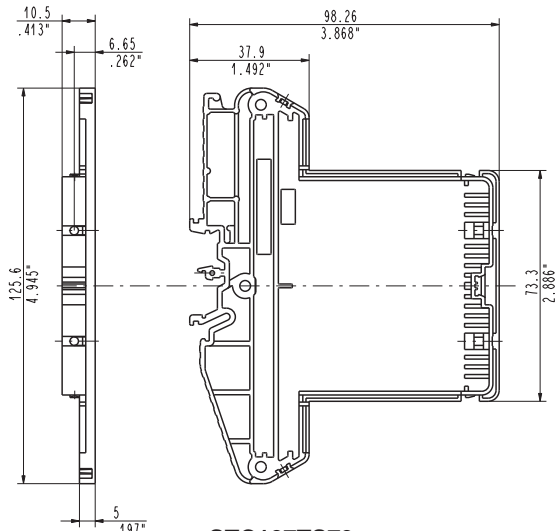

STC107TS73

Right High Lateral Element with Rail Hook

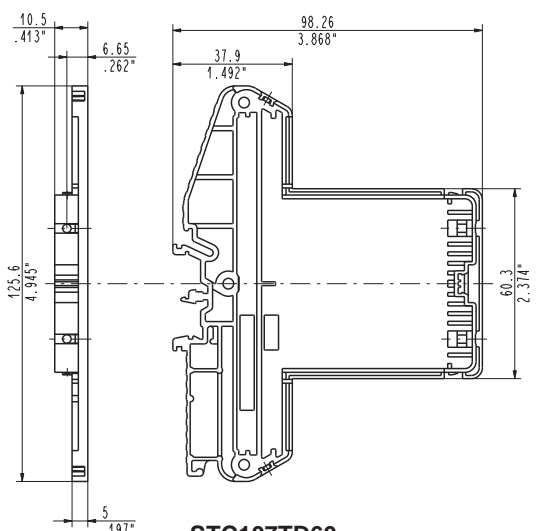

STC107TD60

Right High Lateral Element with Rail Hook

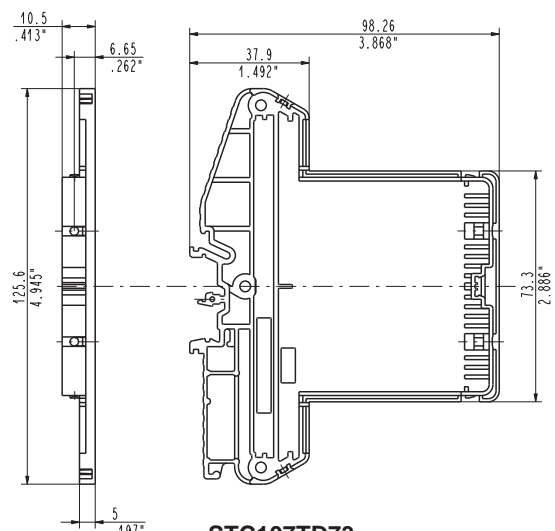

STC107TD73

High Lateral Element Without Rail Hook

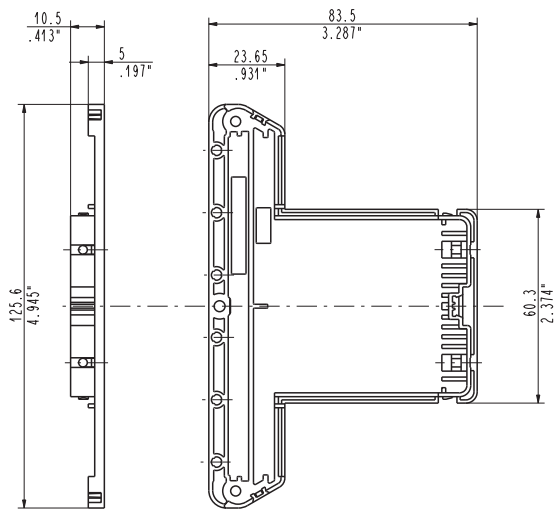

STC107T060

High Lateral Element Without Rail Hook

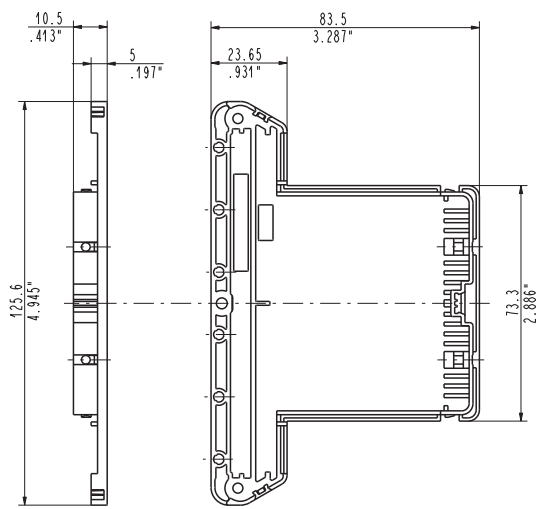

STC107T073

Extruded Supports**STC107T****High Lateral Elements**

High Lateral Elements are necessary if the transparent **Protection Cover** is used and they **differ if a 60 mm (2.362 in) wide Cover or a 73 mm (2.874 in) wide Cover is used**. 4 **Screws** are required to fasten each Protection Cover to the two High Lateral Elements.

High Lateral Elements with Left and Right Rail Hook can be used to fasten the **Extruded PCB Supports** that are quite short and quite lightweight to the DIN rail. Alternatively, it's possible to use 2 **Elements**

Without Hooks by placing the required number of **DIN Rail Hooks** directly under the Extruded Profile.

To fasten each Lateral Element to the Extruded Profile, 3 **Screws** must be used.

For customer convenience, the Support can be supplied with one Lateral Element already assembled. This option, if desired, must be clearly requested.

Description	Part-Number	Pcs / pack
Left High Lateral Element with Rail Hook	STC107TS60	25
Left High Lateral Element with Rail Hook	STC107TS73	25
Right High Lateral Element with Rail Hook	STC107TD60	25
Right High Lateral Element with Rail Hook	STC107TD73	25
High Lateral Element Without Rail Hook	STC107T060	100
High Lateral Element Without Rail Hook	STC107T073	100

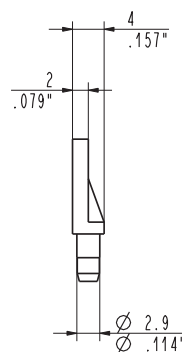
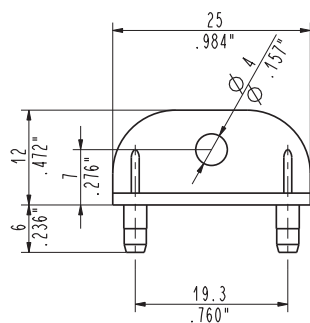
Bracket for Mounting on the Wall

Distributed by:



STC000F000

STC000F000**Bracket for Mounting on the Wall**

A **Bracket for Mounting on the Wall** can be used to fasten the PCB Support to a flat surface rather than hooking it to a DIN rail.

The **Bracket** is suitable only for the **Lateral Elements Without a Rail Hook**, by snapping on, one per Lateral Element.

The **Bracket for Mounting on the Wall** can be used with both **STC072** and **STC107** Series.

Description	Part-Number	Pcs / pack
Bracket for Mounting on the Wall	STC000F000	100

Custom sized 60 mm (2.362 in) Protection Cover

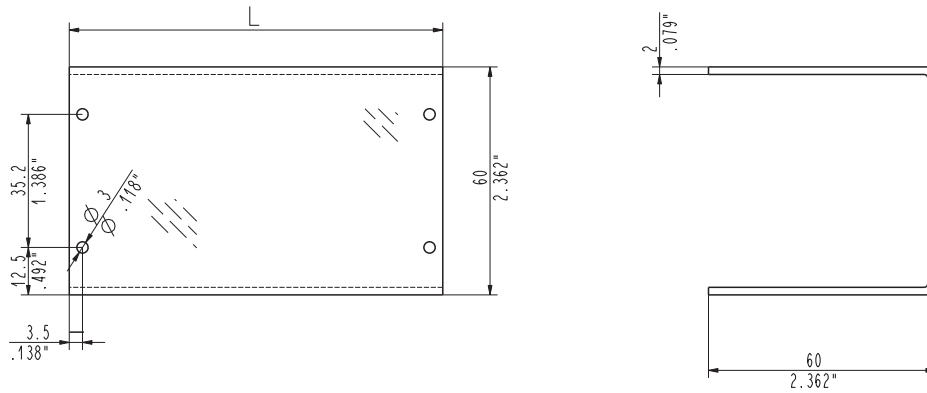

STC107C_ _ _

Custom sized 73 mm (2.874 in) Protection Cover

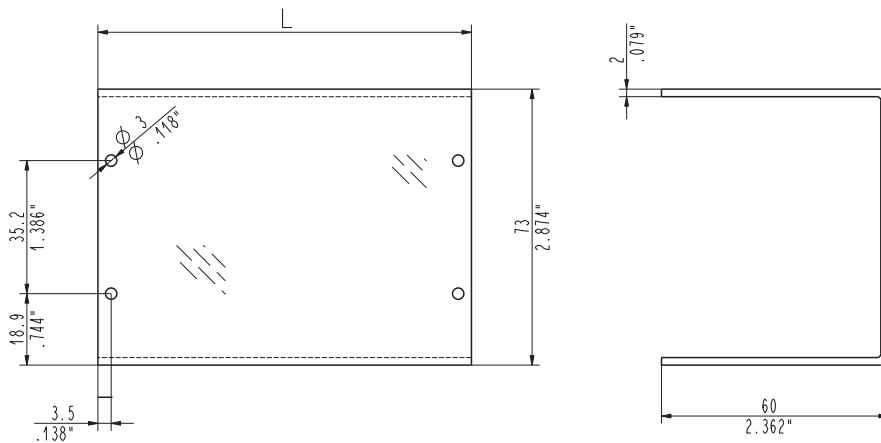

STC107D_ _ _

STC107C_ _ _ / STC107D_ _ _

Custom sized Protection Cover

For Custom sized Protection Cover, length of the piece must be equal to the corresponding length of the Profile, that is the length of the PCB minus 3.5 mm (.137 in). It's advised to round off the figure to the higher whole number.

The Length of the Support, including the Lateral Elements, is equal to the Length of the Profile plus 6 mm (.236 in).

	L	Part-Number	Pcs / pack	For PCB		Support Length	
				(mm)	(in)	(mm)	(in)
Custom size	(for 73 mm (2.874 in) Protection Cover)	STC 107D_ _ _	50	L + 3.5	L +.137	L + 6	L +.236
70 mm	(for 60 mm (2.362 in) Protection Cover)	STC 107C070	50	73.5	2.894	76	2.992
Custom size	(for 73 mm (2.874 in) Protection Cover)	STC 107D_ _ _	50	L + 3.5	L +.137	L + 6	L +.236
70 mm	(for 73 mm (2.874 in) Protection Cover)	STC 107D070	50	73.5	2.894	75	2.992

Extruded Supports

▶ Size Adapter for 100 mm (3.937 in) PCBs

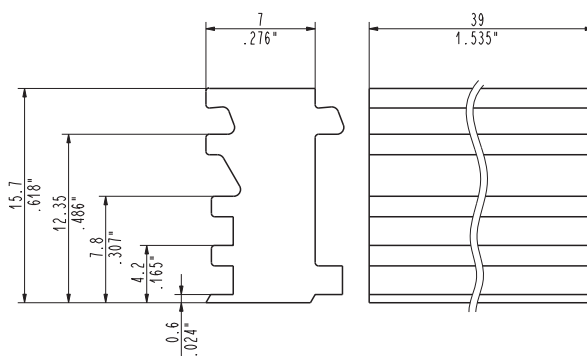

STC107A039

Distributed by:



STC107A039

▶ Adapter for 100 mm (3.937 in) PCBs

The **Adapter for 100 mm (3.937 in) PCBs** is necessary when mounting boards 100 mm (3.937 in) wide on the **STC107** Series Supports. It must be inserted in the Profile lengthwise in the desired side and it doesn't need fastening.

The board will be offset in relation to the centerline of the profile. This position must be taken into consideration if the Protection Cover is used.

The **Adapter for 100 mm (3.937 in) PCBs** is available in **1.535 in (39 mm) standard length**.

It must be used in a quantity that does not exceed the corresponding length of the Profile.

Description	Part-Number	Pcs / pack
Size of STD Adapter for 3.937 in (100 mm) PCB	STC107A039	50

▶ In the following tables some indicative examples of configuration are shown, as might occur in some practical applications.

Example	Extruded Profile	Left Lat. Element	Right Lat. Element	Head Without	DIN Rail	Screw for Head	Bracket for
Without Protection		with Rail Hook	with Rail Hook	Rail Hook	Hook	Fastening	Mounting on the Wall
	STC107_ _ _ _	STC107TSX0	STC107TDX0	STC107T000	STC107P011	STC000V015	STC000F000
Lightweight	1	1	1			6	
Medium Weight	1			2	1	6	
Medium-Heavyweight	1			2	2	6	
Heavyweight	1			2	3	6	
Support to be fastened on a flat surface	1			2		6	2 ÷ 6

Example	Extruded Profile	High Left Lat. Element	High Right Lat. Element	High Head Without	DIN Rail	Screw for Head	Screw for	Bracket for
With Protection	Protection Cover	with Rail Hook	with Rail Hook	Rail Hook	Hook	Fastening	Protection Cover	Mounting on the Wall
	STC107_ _ _ _	STC107TS_ _	STC107TD_ _	STC107T0_ _	STC107P011	STC000V015	STC000VC15	STC000F000
Lightweight	1 + 1	1	1			6	4	
Medium Weight	1 + 1			2	1	6	4	
Medium-Heavyweight	1 + 1			2	2	6	4	
Heavyweight	1 + 1			2	3	6	4	
Support to be fastened on a flat surface	1 + 1			2		6	4	2 ÷ 6

EXAMPLES OF INSTALLATION

STC107 Extruded support

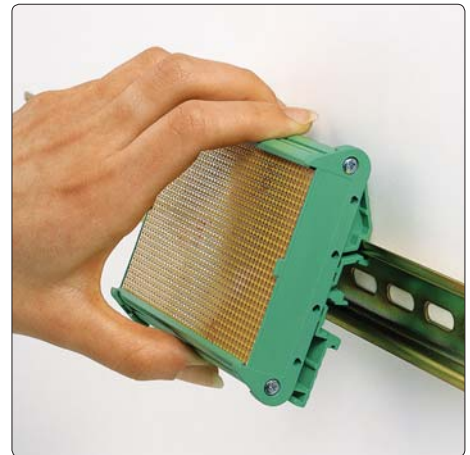
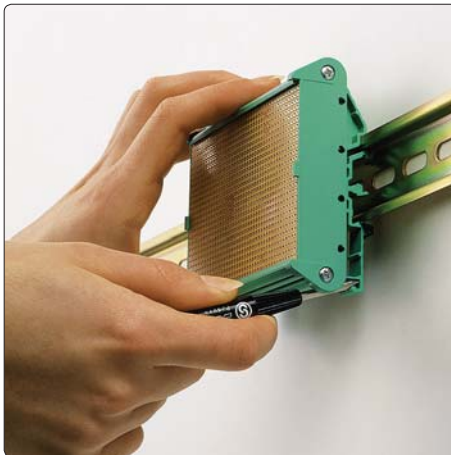
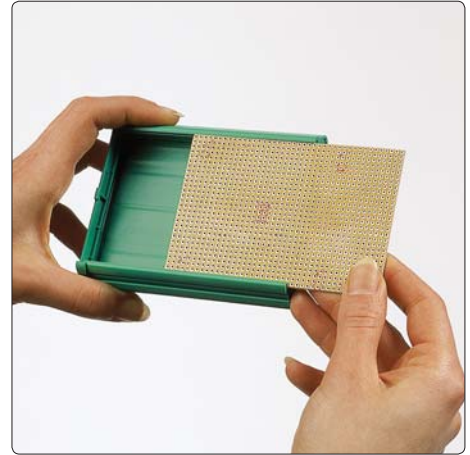

STC107 Extruded support

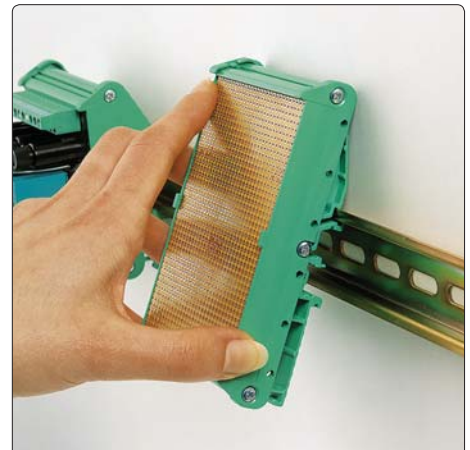

Distributed by:



TEXIM EUROPE

Partner in Electronic Components & Supply Chain Solutions



The Netherlands

Elektrostraat 17
NL-7483 PG Haaksbergen
Tel: +31 (0)53 573 33 33
Fax: +31 (0)53 573 33 30
nl@texim-europe.com



Denmark

Nørregade 15
DK-9240 Nibe
Tel: +45 88 20 26 30
Fax: +45 88 20 26 39
nordic@texim-europe.com



Belgium

Gentsesteenweg 1154-C22
Chaussée de Gand 1154-C22
B-1082 Brussel / Bruxelles
Tel: +32 (0)2 462 01 00
Fax: +32 (0)2 462 01 25
belgium@texim-europe.com



United Kingdom

St. Mary's House, Church Lane
Carlton Le Moorland
Lincoln LN5 9HS
Tel: +44 (0)1522 789 555
Fax: +44 (0)845 299 22 26
uk@texim-europe.com



Germany

Justus-von-Liebig-Ring 7-9
D-25451 Quickborn
Tel: +49 (0)4106 627 07-0
Fax: +49 (0)4106 627 07-20
germany@texim-europe.com



Germany

Martin-Kollar-Strasse 9
D-81829 München
Tel: +49 (0)89 436 086-0
Fax: +49 (0)89 436 086-19
germany@texim-europe.com



Austria

Warwitzstrasse 9
A-5020 Salzburg
Tel: +43 (0)662 216026
Fax: +43 (0)662 216026-66
austria@texim-europe.com

Texim Europe B.V.

Elektrostraat 17
NL-7483 PG Haaksbergen
Tel: +31 (0)53 573 33 33
info@texim-europe.com
www.texim-europe.com

