



**CUSTOMER' S APPROVAL SPECIFICATIONS**

**MODEL: CH%\$%@ L-00%**

**(Complied with RoHS)**

ISSUE:LCP.38.2016

**Spec Condition: preliminary**

No.	ITEM	PAGE
1	COVER	--
2	RECORD OF REVISION	0-1
3	MECHANICAL SPECIFICATIONS	1
4	OUTLINE DIMENSIONS	2
5	INTERFACE PIN CONNECTION	3
6	BLOCK DIAGRAM	4
7	ABSOLUTE MAXIMUM RATINGS	4
8	ELECTRICAL CHARACTERISTICS	5
9	OPTICAL CHARACTERISTICS	6~8
10	TIMING SPECIFICATIONS	9~10
11	RELIABILITY TEST	11
12	PRECAUTIONS FOR USE	12~13
13	LCM INSPECTION STANDARD	14~19

CUSTOMER	CHEFREE		
APPROVAL	APPROVAL	CHECKER	PREPARE
	ch lee	kevin	kevin



### 3.MECHANICAL SPECIFICATIONS

(1)	Number Of Dots (Dots)	1024(R.G.B) X 600
(2)	Module Size(mm)	235.0(W) X 143.0(H) X 7.54(D)
(3)	Active Area(mm)	222.72(H) X 125.28(V)
(4)	Pixel Pitch(mm)	0.2175 (H) X 0.2088(V)
(5)	LCD Model	TFT , Transmissive, Normally/White
(6)	Polarizer Model	Anti-glare(3H)
(7)	LED Backlight Color	White
(8)	Viewing Direction	Wide Viewing Angle
(9)	Gray Scale Inversion Direction	12 O'CLOCK
(10)	Color Configuration	R.G.B Stripe
(11)	Module Weight(g)	310±10%

4. OUTLINE DIMENSIONS

1 文件題目	2 圖號	3 頁	4 次頁
發行日	舊版日	登入號碼	機密等級

7		8 樣式 QT2-RD02-008	
No.	修定區塊	修訂內容	作成
		新版	Swallow
			修訂日期
			2014.01.16

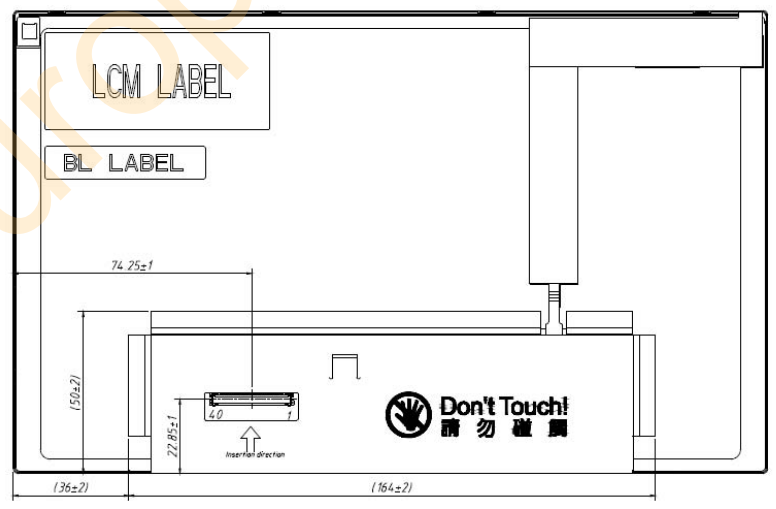
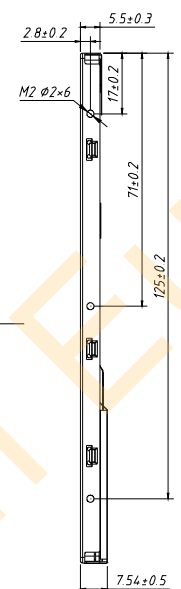
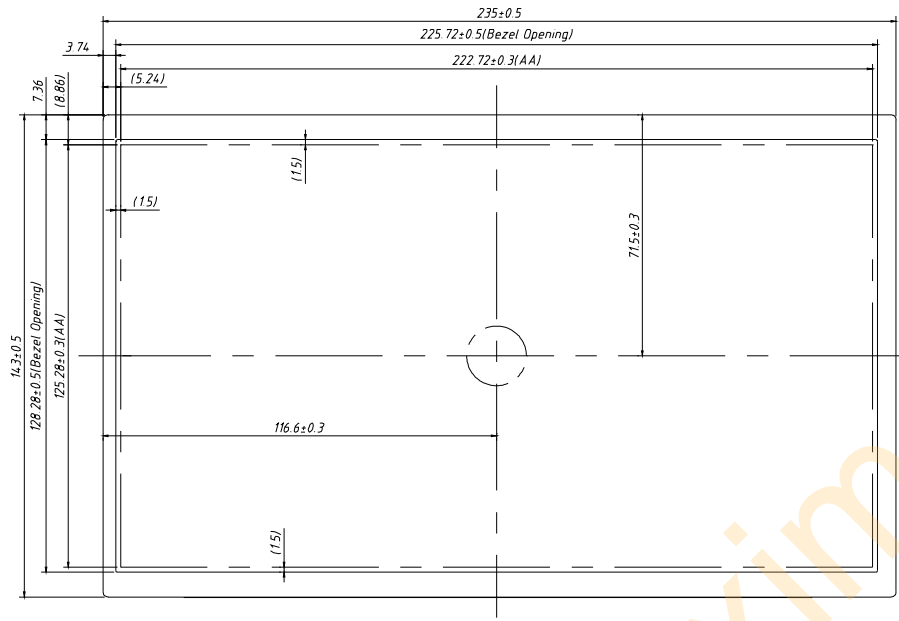

NOTE:  
 1. Unit: mm  
 2. Tolerance is ±0.3 mm unless noted.

備考	單位: mm	投影法:	比例尺:
入庫	製圖 Swallow 140116	名稱: 10.1"	圖號: CH1011LFL-001
	審查		
	承認		

## 5. INTERFACE PIN CONNECTION

### 5.1 LCM PANEL DRIVING SECTION

CN1:STM MSAK24025P40D or equivalent

Pin #	Signal Name	Description	Remarks
1	BIST	BIST MODE SELECT(High Enable)	FOR INTERNAL TEST
2	VDD	LCD power supply (Typ. +3.3V)	
3	VDD	LCD power supply (Typ. +3.3V)	
4	V_EDID	EDID power supply	
5	NC	No connection	
6	CLK_EDID	EDID CLK signal	
7	Data_EDID	EDID Data signal	
8	LVDS input 0-	LVDS CH0 data signal(-) 、 R0~R5 、 G0	
9	LVDS input 0+	LVDS CH0 data signal(+) 、 R0~R5 、 G0	
10	GND	GND	
11	LVDS input 1-	LVDS CH1 data signal(-) 、 G1~G5 、 B0 、 B1	
12	LVDS input 1+	LVDS CH1 data signal(+) 、 G1~G5 、 B0 、 B1	
13	GND	GND	
14	LVDS input 2-	LVDS CH2 data signal(-) 、 B2~B5 、 DE	
15	LVDS input 2+	LVDS CH0 data signal(+) 、 B2~B5 、 DE	
16	GND	GND	
17	LVDS CLK -	LVDS CLK data signal(-)	
18	LVDS CLK +	LVDS CLK data signal(+)	
19	GND	GND	
20	LVDS input 3-	LVDS CH3 data signal(-) 、 R6~R7 、 G6~G7 、 B6~B7	
21	LVDS input 3+	LVDS CH3 data signal(+) 、 R6~R7 、 G6~G7 、 B6~B7	
22	GND	GND	
23	NC	No connection	
24	NC	No connection	
25	GND	GND	
26	NC	No connection	
27	NC	No connection	
28	GND	GND	
29	NC	No connection	
30	NC	No connection	
31	GND	GND	
32	GND	GND	

33	GND	GND	
34	NC	No connection	
35	PWM	LED dimming signal	
36	LED_EN	LED Enable signal	
37	NC	No connection	
38	VLED	LED power supply (Typ. 5V)	
39	VLED	LED power supply (Typ. 5V)	
40	VLED	LED power supply (Typ. 5V)	

## 6. BLOCK DIAGRAM

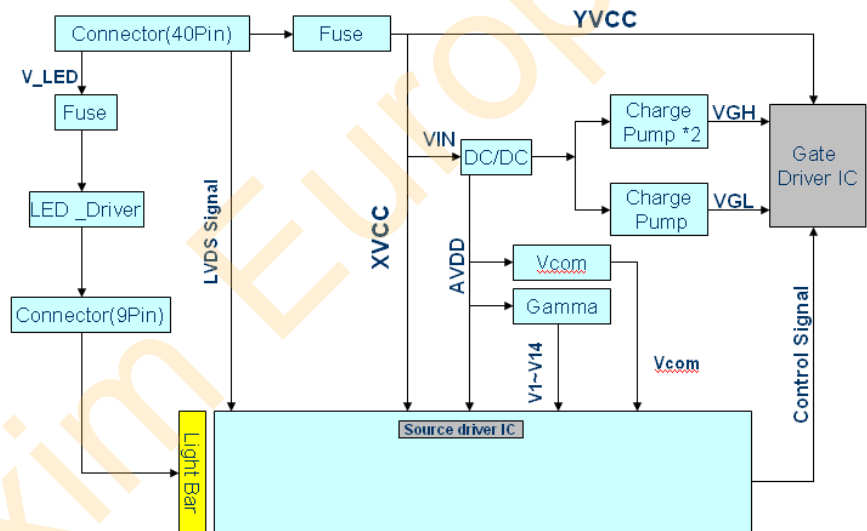

## 7. ABSOLUTE MAXIMUM RATINGS

### 7.1 ELECTRICAL ABSOLUTE MAXIMUM RATINGS

ITEM	SYMBOL	MIN.	MAX.	UNIT	REMARK
Logic Power Supply Voltage	VDD	3.0	3.6	V	
LED Backlight Drive Voltage	VLED	-0.3	12	V	
LVDS Input Signal	V <sub>S</sub>	-0.3	3.6	V	
PWM Dimming Voltage	V <sub>PWM</sub>	-0.3	12	V	

### 7.2 ENVIRONMENTAL ABSOLUTE MAXIMUM RATINGS

ITEM	OPERATING		STORAGE		REMARK
	MIN	MAX	MIN	MAX	
Ambient Temperature(°C)	-20	70	-30	80	Note 1,2

Note 1 : The response time will become lower when operated at low temperature.

Note 2 : Background color changes slightly depending on ambient temperature.

## 8. ELECTRICAL CHARACTERISTICS

### 8.1 ELECTRICAL CHARACTERISTICS OF LCD

ITEM	SYMBOL	MIN.	TYP.	MAX.	UNIT	CONDITIONS
System Power Supply						
Input Power Supply Voltage	$V_{IN}$	3.0	3.3	3.6	V	
Input Power Supply Current	$I_{VIN}$	-	-	217	mA	Black pattern · 60Hz
Input Inrush Current	$I_{RUSH}$	-	-	1.5	A	0.5ms rise time (10%~90%)
Input Power Voltage Ripple	$V_{RPL}$	-	-	200	mV	Vp-p
LED Power Supply						
Input Power Supply Voltage	$V_{LED-IN}$	4.5	5	5.5	V	
Input Power Supply Current	$I_{IN}$	-	-	586	mA	$V_{LED}=4.5V, \eta=85\%$
EN/PWM	VH	2.0	-	5.0	V	
	VL	0	-	0.5	V	
LVDS Signals						
Differential Input High Threshold	$V_{th}$	-	-	+100	mV	$V_{cm}=+1.2V$
Differential Input Low Threshold	$V_{tl}$	-100	-	-	mV	$V_{cm}=+1.2V$
Magnitude Differential Input Voltage	$ V_{id} $	200	-	600	mV	
Common Mode Voltage	$V_{cm}$	1.0	1.2	1.4	V	$V_{th} - V_{tl} = 200mV$
Common Mode Voltage Offset	$\Delta V_{cm}$	-50	-	+50	mV	$V_{th} - V_{tl} = 200mV$
EDID Power Supply						
Input Power Supply Voltage	$V_{EDID}$	3.0		3.6	V	

Note: A. Input signals shall be low or Hi-Z state when VIN is off.

B. All electrical characteristics for LVDS signal are defined and shall be measured at the interface connector of LCD.

C. White Pattern at 3.3V driving voltage.

### 8.2 BACKLIGHT UNITS

$T_a=25^\circ C$

ITEM	SYMBOL	MIN.	TYP.	MAX.	UNIT	REMARK
LED Driving Voltage	VLED	4.5	5	5.5	V	
LED Driving Current	ILED	-	-	585	mA	
Brightness Control	VIH	2	3.3	5	V	
	VIL	0	-	0.8	V	
PWM Frequency	$F_{PWM}$	200		1K	Hz	
LED Life Time	-	30000	-	-	Hr	Note1

Note1 : The LED life time define as the estimated time to 50% degradation of the initial value.

9. OPTICAL CHARACTERISTICS

Ta=25°C

ITEM	SYMBOL	CONDITIONS	MIN.	TYP.	MAX.	UNIT	REMARK
Contrast Ratio	CR	Viewing	(400)	(500)	-	-	Note (1)
Response Time	T <sub>R</sub> + T <sub>F</sub>	Normal	-	16	20	ms	Note (2)
		Angle Θ <sub>x</sub> =Θ <sub>y</sub> =0°					
Chromaticity	White	x	(0.255)	(0.305)	(0.355)	-	Note (4)
		y	(0.275)	(0.325)	(0.375)		
Viewing Angle	Hor.	Θ <sub>x</sub> +	(70)	(80)	-	Deg.	Note (3)
		Θ <sub>x</sub> -	(70)	(80)	-		
	Ver.	Θ <sub>y</sub> +	(50)	(60)	-		
		Θ <sub>y</sub> -	(70)	(80)	-		
Luminance	L	Center	(280)	(350)	-	cd/m <sup>2</sup>	Note (4)
Luminance uniformity	YU	PWM=100%	70	80	-	%	Note (5)

\*Note (1) Definition of Contrast Ratio (CR):

The contrast ratio can be calculated by the following expression.

$$\text{Contrast Ratio (CR)} = L_{63} / L_0$$

L<sub>63</sub>: Luminance of gray level 63

L<sub>0</sub>: Luminance of gray level 0

$$CR = CR (5)$$

CR (X) is corresponding to the Contrast Ratio of the point X at Figure in Note (5).

\*Note (2) Definition of Response Time (T<sub>R</sub>, T<sub>F</sub>):

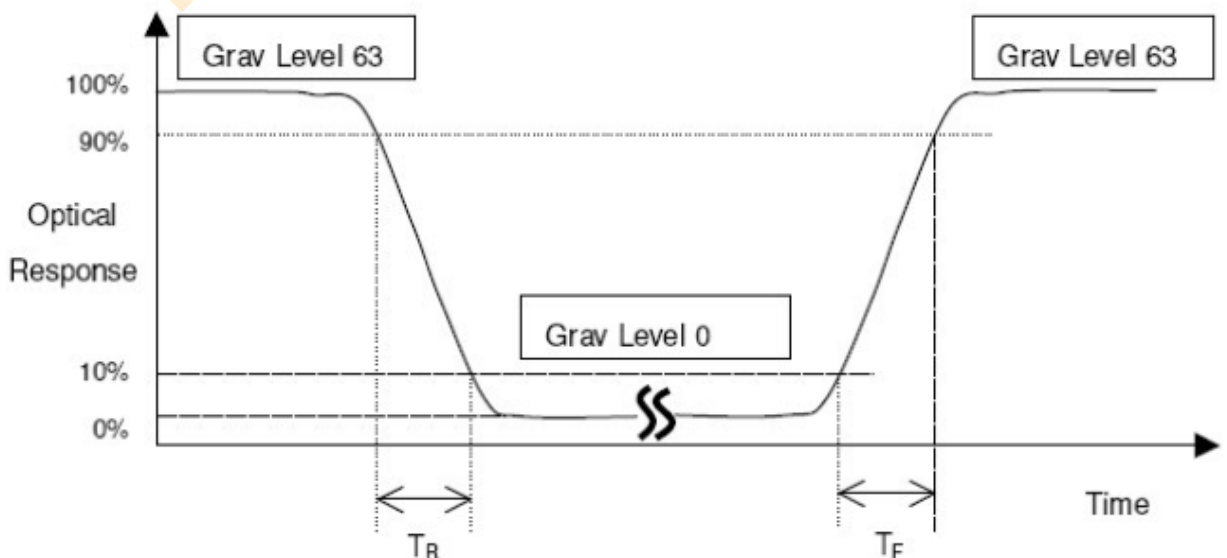



\*Note(3) Definition of Viewing Angle

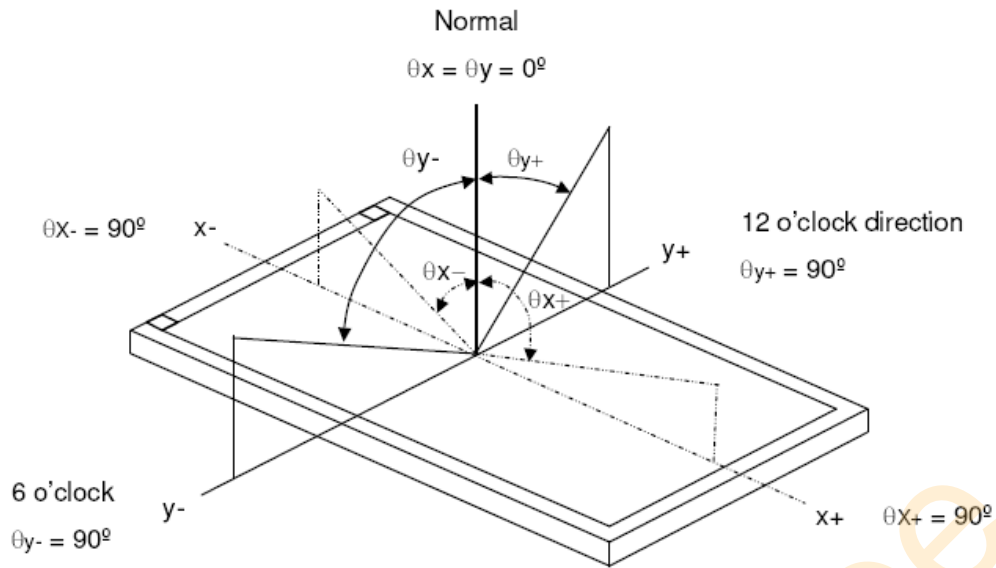

\*Note (4) Measurement Set-Up:

The LCD module should be stabilized at a given temperature for 20 minutes to avoid abrupt temperature change during measuring. In order to stabilize the luminance, the measurement should be executed after lighting Backlight for 20 minutes in a windless room.

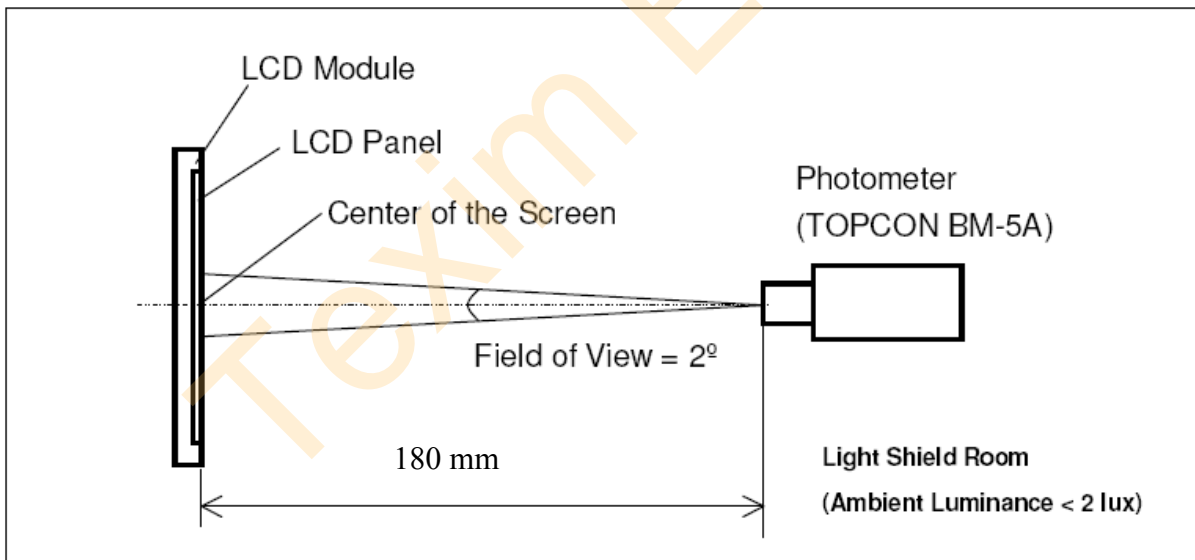

\*Note (5)

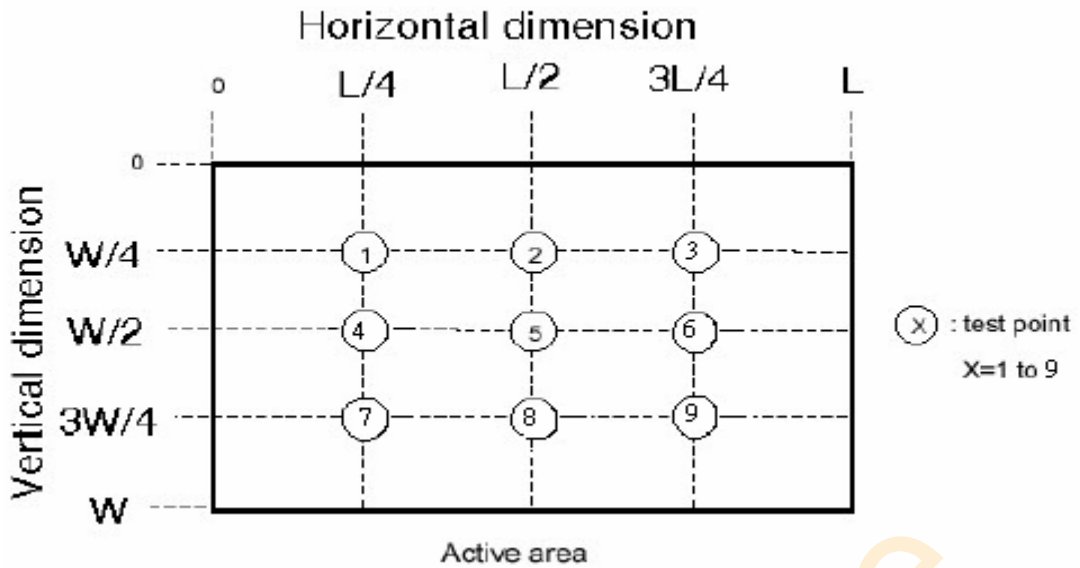

$$\left( 1 - \frac{\text{MAX Luminance} - \text{Average Luminance}}{\text{Average Luminance}} \right) \times 100\% > 70\%$$

### 3.0 Pixel Format Image

Figure 2 shows the relationship of the input signals and LCD pixel format image.

Figure 2 Pixel Format

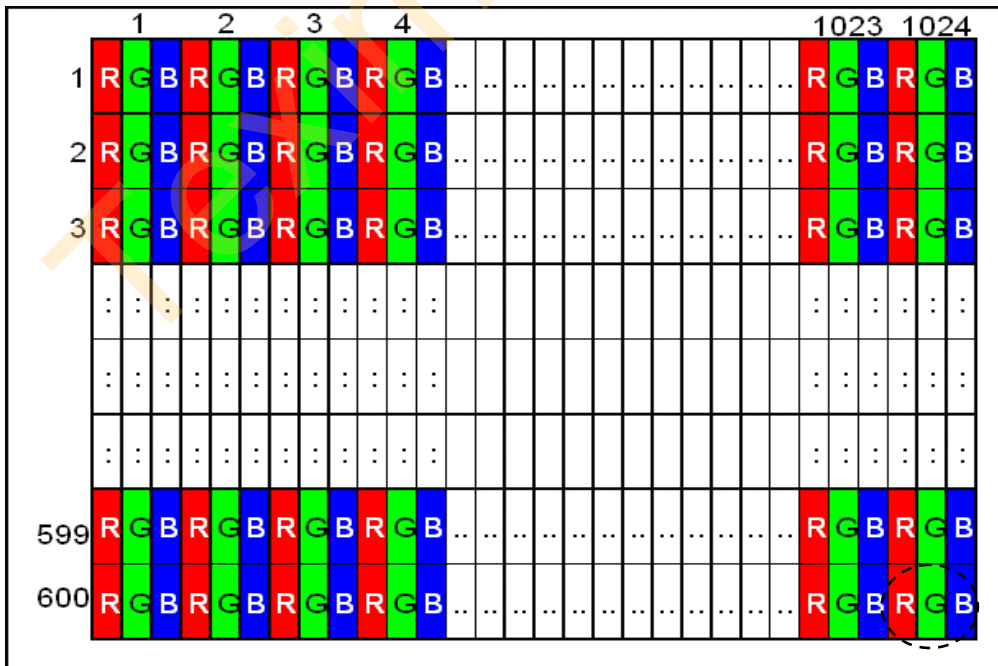

R+G+B dots =1 Pixel

# 10. TIMING SPECIFICATIONS

## 10.1 POWER ON/OFF SEQUENCE

Parameter	Symbol	Unit	min	Typ.	max
VDD rising Time	T1	ms	0.5	--	10
VDD Good to Signal Valid	T2	ms	30	--	90
Signal Valid to Backlight on	T3	ms	200	--	--
Backlight Power on time	T4	ms	0.5	--	--
Backlight VDD Good to System PWM on	T5	ms	10	--	--
System PWM on to Backlight Enable on	T6	ms	10	--	--
Backlight Enable off to System PWM off	T7	ms	0	--	--
System PWM off to B/L Power Disable	T8	ms	10	--	--
Backlight Power off time	T9	ms	1	10	30
Backlight off to signal Disable	T10	ms	200	--	--
Signal Disable to Power Down	T11	ms	0	--	50
VDD Falling Time	T12	ms	1	10	30
Power Off	T13	ms	500	--	--

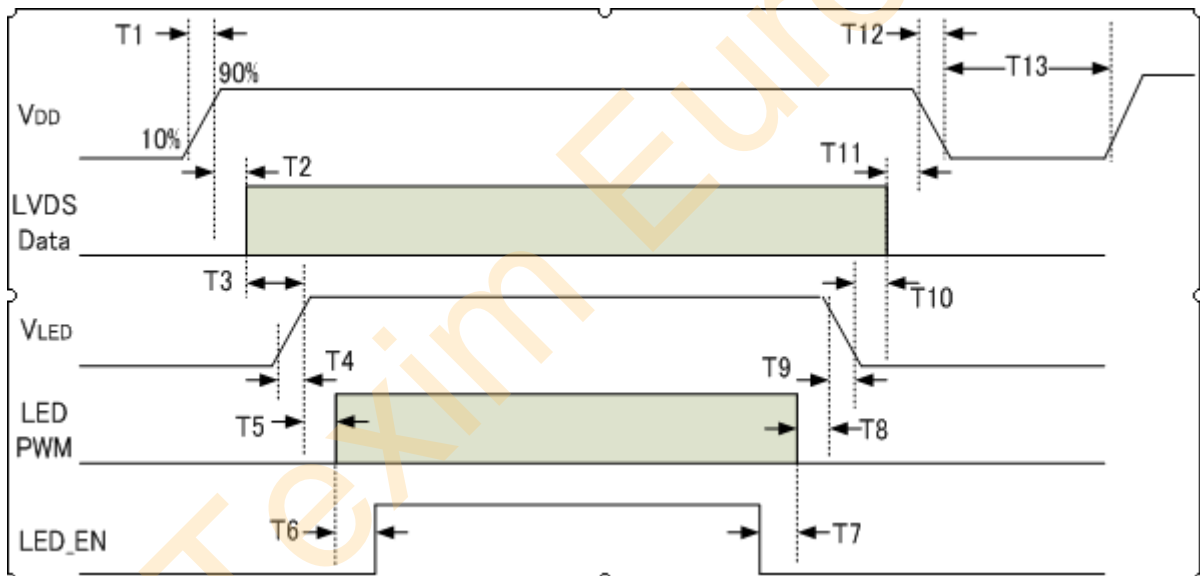

### Power Consumption

Input power specifications are as follows.

Item	Symbol	Min.	Typ.	Max.	Units	Note
Input Power Supply Voltage	$V_{IN}$	3.0	3.3	3.6	V	
Input Power Supply Current	$I_{VIN}$	-	-	217	mA	Black pattern , 60Hz
Input Inrush Current	$I_{RUSH}$	-	-	1.5	A	0.5ms rise time (10%~90%)
Input Power Voltage Ripple	$V_{RPL}$	-	-	200	mV	Vp-p

## 10.2 TIMING CHARACTERISTICS

Synchronization Method : DE only

Parameter	Symbol	Unit	Min.	Typ.	Max.
LVDS Clock Frequency <single>	$f_{dck}$	MHz	45	51.2	65
H Total Time	$T_{hp}$	clocks	1,324	1,344	1,364
H Active Time	HA	clocks	1,024	1,024	1,024
H Blanking Time	$TH_{BLANK}$	clocks	300	320	340
V Total Time	$T_{vp}$	lines	615	635	645
V Active Time	VA	lines	600	600	600
V Blanking Time	$TV_{BLANK}$	lines	15	35	45
V Frequency	$f_v$	Hz	55	60	65

Figure 7 DE-only timing mode

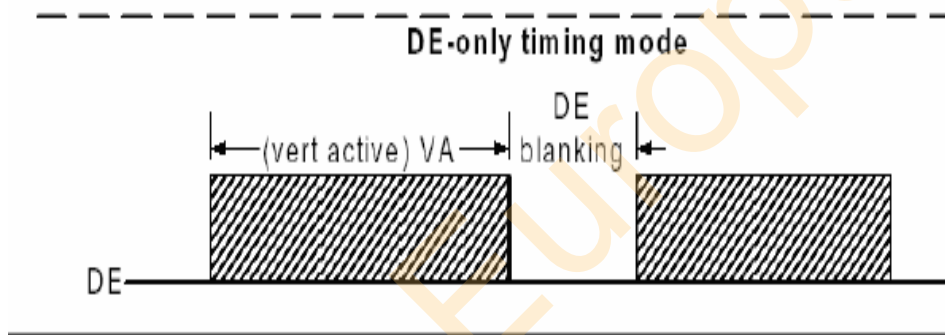

### Timing Diagram of Interface Signal

Figure 8 LVDS Data Mapping

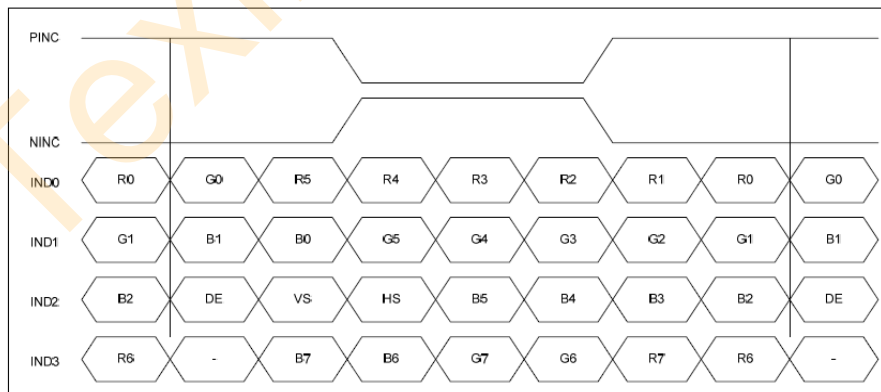

## 11. RELIABILITY TEST

ENVIRONMENTAL TEST FOR LCM				
NO.	ITEM	CONDITIONS	TIME PERIOD	REMARK
1	High Temperature Storage	80°C	300HRS	Note1,4
2	Low Temperature Storage	-30°C	300HRS	Note1,4
3	High Temperature Operation	70°C	300HRS	Note2,4
4	Low Temperature Operation	-20°C	300HRS	Note1,4
5	High Temperature Humidity Storage	50°C 85%RH	300HRS	Note2,4
6	Temperature Cycle	-20°C → 60°C (30min) (30min)	100CYCLE	Note1,4

Note1 : Ta is the ambient temperature of samples.

Note2 : Ts is the temperature of panel's surface.

Note3 : In the standard condition, there shall be no practical problem that may affect the display function. After the reliability test, the product only guarantees operation, but don't guarantee all of the cosmetic specification.

Note4 : Before cosmetic and function test, the product must have enough recovery time, at least 2 hours at room temperature.

Thermal Shock Test	-20°C~60°C, 1h/each cycle,100cycles	
Shock Test (Non-Operating)	50G,20ms,Half Sine Wave, (±X, ±Y,±Z)	
Vibration Test (Non-Operating)	1.5G ,10~200 Hz, x、 y、 z each axis/30min	
ESD test	Contact Discharge: ±8KV,150pF(330 Ω) ; Air Discharge: ±15KV,150pF(330 Ω)	Note 1

Note1: ESD class C: Performance could be recovered by reset if temporary failure happened.

## 12. PRECAUTIONS FOR USE

### 12.1 USE RESTRICTION

This product is not authorized for use in life supporting systems, aircraft navigation control systems, military systems and any other application where performance failure could be life-threatening or otherwise catastrophic.

### 12.2 HANDLING PRECAUTION

- (1) Please mount LCD module by using mounting holes arranged in four corners tightly.
- (2) Do not disassemble or modify the module. It may damage sensitive parts inside LCD module, and may cause scratches or dust on the display. CHEFREE does not warrant the module, if customers disassemble or modify the module.
- (3) If LCD panel is broken and liquid crystal spills out, do not ingest or inhale liquid Crystal, and do not contact liquid crystal with skin. If liquid crystal contacts mouth or eyes, rinse out with water immediately. If liquid crystal contacts skin or cloths, wash it off immediately with alcohol and Rinse thoroughly with water.
- (4) Disconnect power supply before handling LCD module
- (5) Refrain from strong mechanical shock and /or any force to the module.
- (6) Do not exceed the absolute maximum rating values, such as the supply voltage variation, input voltage variation, variation in parts' parameters, environmental temperature; etc otherwise LCD module may be damaged. It's recommended employing protection circuit for power supply.
- (7) Do not touch, push or rub the polarizer with anything harder than HB pencil lead. Use fingerstalls of soft gloves in order to keep clean display quality, when Persons handle the LCD module for incoming inspection or assembly.
- (8) When the surface is dusty, please wipe gently with absorbent cotton or other soft Material. When cleaning the adhesives, please use absorbent cotton wetted with a little Petroleum benzene or other adequate solvent.
- (9) Wipe off saliva or water drops as soon as possible. If saliva or water drops Contact with polarizer for a long time, they may causes deformation or color Fading.
- (10) Protection film must remove very slowly from the surface of LCD module to Prevent from electrostatic occurrence.
- (11) Because LCD module uses CMOS-IC on circuit board and TFT-LCD panel, it is Very weak to electrostatic discharge, Please be careful with electrostatic Discharge .Persons who handle the module should be grounded through adequate methods.
- (12) Do not adjust the variable resistor located on the module.

### 12.3 STORAGE PRECAUTION

- (1) Please do not leave LCD module in the environment of high humidity and high temperature for a long time.
- (2) The module shall not be exposed under strong light such as direct sunlight. Otherwise, Display characteristics may be changed.
- (3) The module should be stored in a dark place. It is prohibited to apply sunlight or fluorescent light in storage.

#### 12.4 OPERATION PRECAUTION

- (1) Do not connect or disconnect the module in the "Power On" condition.
- (2) Power supply should always be turned on/off by 9.0 "Power on/off sequence"
- (3) Module has high frequency circuits. Sufficient suppression to the electromagnetic interference should be done by system manufacturers. Grounding and shielding methods may be important to minimize the interference.
- (4) After installation of the TFT Module into an enclosure, do not twist nor bend the TFT Module even momentary. At designing the enclosure, it should be taken into consideration that no bending/twisting forces are applied to the TFT Module from outside. Otherwise the TFT Module may be damaged.

#### 12.5 OTHERS

- (1) Ultra-violet ray filter is necessary for outdoor operation.
- (2) Avoid condensation of water which may result in improper operation or disconnection of electrode
- (3) If the module keeps displaying the same pattern for a long period of time, the image may be "sticked" to the screen.
- (4) This module has its circuitry PCB's on the rear side and should be handled carefully in order not to be stressed.

#### 12.6 DISPOSAL

When disposing LCD module, obey the local environmental regulations.

# 13. LCM INSPECTION STANDARD

## 13.1 INSPECTION AND ENVIRONMENT CONDITIONS

### 13.1.1 Inspection Conditions:

(1) Inspection Distance: 35 cm±5cm

(2) View Angle:

Light-on Inspection Angle : ±10°

Cosmetic Inspection Angle : ±10°

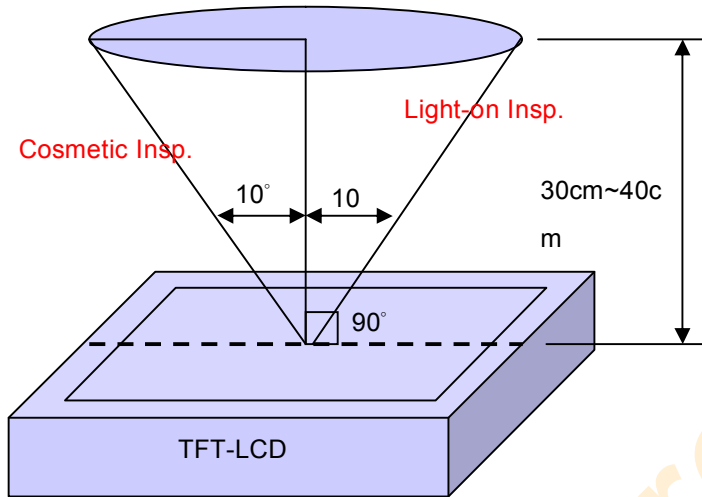

### 13.1.2 Environment Conditions:

Ambient Temperature		15~25°C
Ambient Humidity		25~75%RH
Ambient Illumination	Cosmetic Inspection	400~600 Lux
	Functional Inspection	100~200 Lux

### 13.1.3 Sampling Conditions:

(1) Lot Size: Quantity of shipment lot per model

(2) Sampling Method:

Sampling Plan		MIL-STD-105E
		Normal Inspection, Single Sampling
		Level II
AQL	Major Defect	0.5%
	Minor Defect	1.5%

(3) The classification of Major(MA) and Minor(MI) defects is shown as 4. Inspection Criteria.



## 13.2 INSPECTION CRITERIA

### 13.2.1 Cosmetic Inspection(Panel):

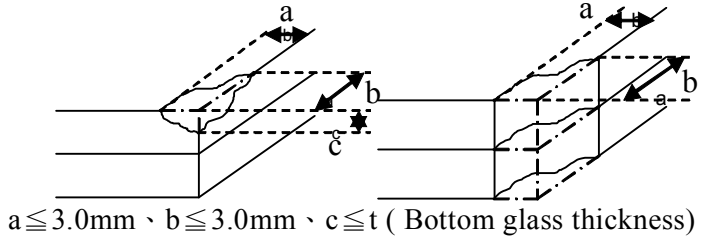
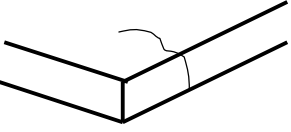
ITEM	JUDGMENT CRITERIA	CLASSIFICATION	ZONE
Chipping on Panel/Touch Panel	 <p><math>a \leq 3.0\text{mm}</math>、<math>b \leq 3.0\text{mm}</math>、<math>c \leq t</math> ( Bottom glass thickness)</p>	MA	C
Scratch on Panel/Touch Panel *Note-2	$W \leq 0.03\text{mm}$ : Ignored $0.03\text{mm} < W \leq 0.05\text{mm}$ and $L \leq 3.0\text{mm}$ : $N \leq 4$ $0.05\text{mm} < W \leq 0.1\text{mm}$ and $L \leq 2.0\text{mm}$ : $N \leq 2$ $W > 0.1\text{mm}$ : Not allowed	MI	C
Bubble or Dent on Panel/Touch Panel *Note-3	$D \leq 0.2\text{mm}$ : Ignored/不計 $0.2\text{mm} < D \leq 0.3\text{mm}$ : $N \leq 2$ $D > 0.3\text{mm}$ : Not allowed	MI	C
Panel/Touch Panel Crack	 <p>Not Allowed crack</p>	MA	C
Bezel Deformation	Obvious deformation is not allowed	MI	C
Bezel Oxidation	Not allowed if it rusts continuously over 1 cm (It is out of warranty with rusted tin plate)	MI	C
*Note-2 Bezel Scratch	Non-feeling abrasion: Ignored feeling abrasion , $L \leq 20\text{mm}$ , $W \leq 0.3\text{ mm}$ , $N \leq 7$ Not allowed	MI	C
*Note-3 Metal Squash Dent /Flange(Front Side)	$D(W) \leq 1\text{ mm}$ , $L \leq 3$ , $N \leq 4$ ;	MI	C
B/L High Voltage Wire Denudation	Not allowed	MA	C
Polarizer flaw or leak out resin	Defect is defined as the active area.	MI	C
Outline Dimension	Must in Spec, refer to related product spec.	MI	C

13.2.2 Functional Inspection:

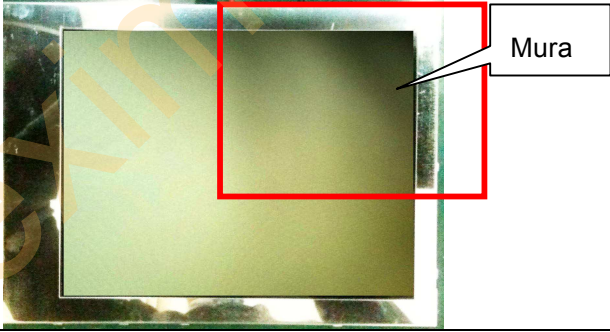
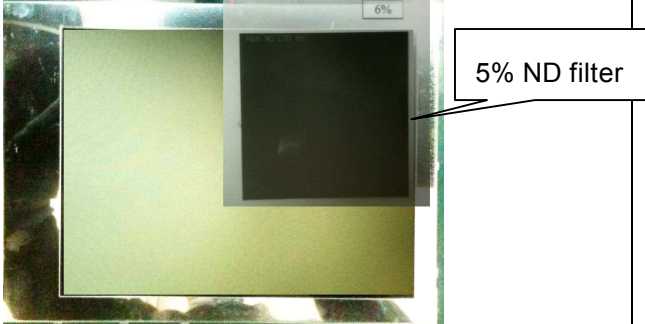
ITEM	JUDGMENT CRITERIA			CLASSIFICATION	ZONE	
Point Defect *Note-6~10	Bright dot	Random	3	MI	A	
		2 dots adjacent	1			
	Dark dot	Random	3			
		2 dots adjacent	1			
	Total Dot Defect					5
	Distance *Note-11	Distance between Bright and Bright dot	$L \geq 15\text{mm}$			
		Distance between Bright and Dark dot	$L \geq 15\text{mm}$			
		Distance between Dark dot	$L \geq 5\text{mm}$			
	Bubble	Average diameter D(mm)	Maximum number acceptable			
		$D \leq 0.15$	Ignore			
$0.15 < D \leq 0.5$		$N \leq 4$				
Line Defect	Obvious vertical or horizontal line defect is not allowed.			MA	A , B	
Mura	<p>1. Mura Definition: Under the normal examination angle of view, the picture has the non-uniform phenomenon.</p> 			MI	A , B	
	<p>2. Weak defect will be defined as Mura if it can be Observed through ND filter 5%</p> 					

ITEM	JUDGMENT CRITERIA	CLASSIFICATION	ZONE
*Note-4 Foreign Material in spot shape	$D \leq 0.15\text{mm}$ : Ignored $0.15\text{mm} < D \leq 0.5\text{mm}$ : $N \leq 4$ $D > 0.5\text{mm}$ : Not allowed	MI	A
*Note-3 Foreign Material in line or spiral shape	$W \leq 0.03\text{mm}$ : Ignored $0.05\text{mm} < W \leq 0.1\text{mm}$ and $L \leq 5\text{mm}$ : $N \leq 4$ $W > 0.1\text{mm}$ or $L > 5\text{mm}$ Not allowed	MI	
Display Function Abnormal	No Malfunction can be allowed	MA	A , B
Touch panel Malfunction	No Malfunction can be allowed in AA area.	MA	

Note 1 : I/O Area Definition

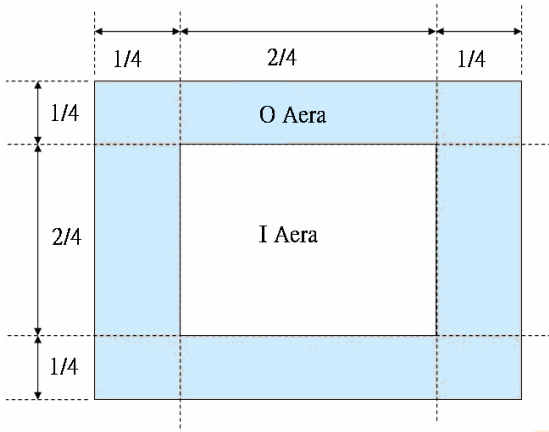

Note 2 : Polarizer Scratch

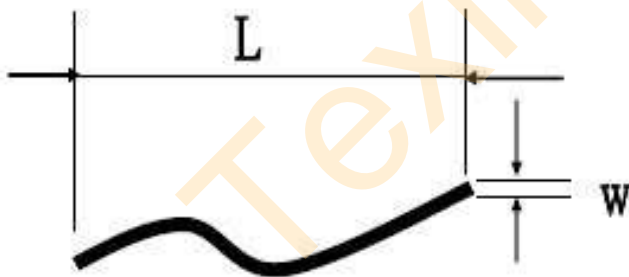

Note 3 : Line or Spiral Foreign Material

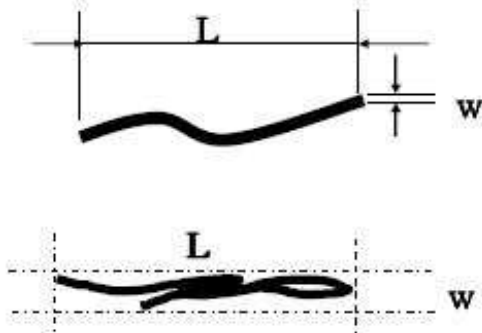

Note 4 : Spot Foreign Material

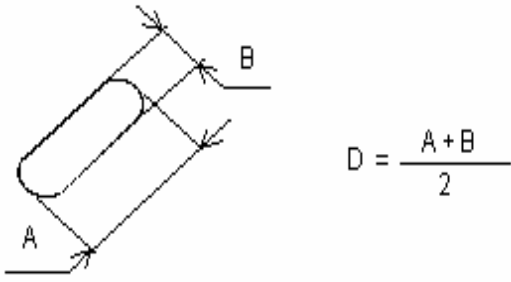

Note 5 : TP Inspection Area Definition

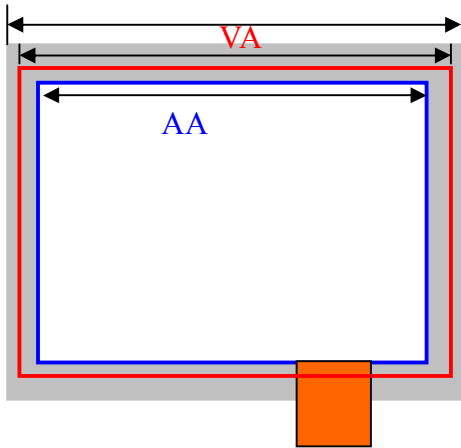

Note 6 : Bright dot defect description:



Note 7 : Dark dot defect description:

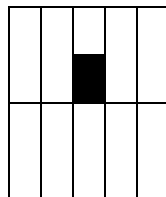

Note 8 : Bright dot defect description- Two adjacent.

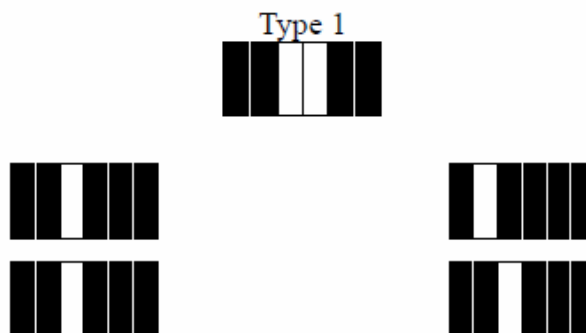

Note 9 : Dark dot defect description- Two adjacent.

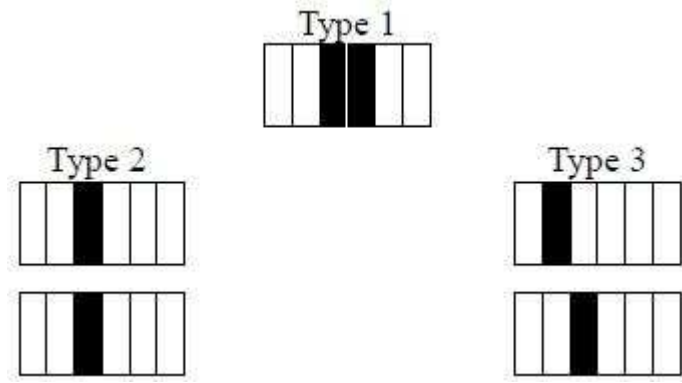

Note 10 : Dark dot defect description- Three adjacent.

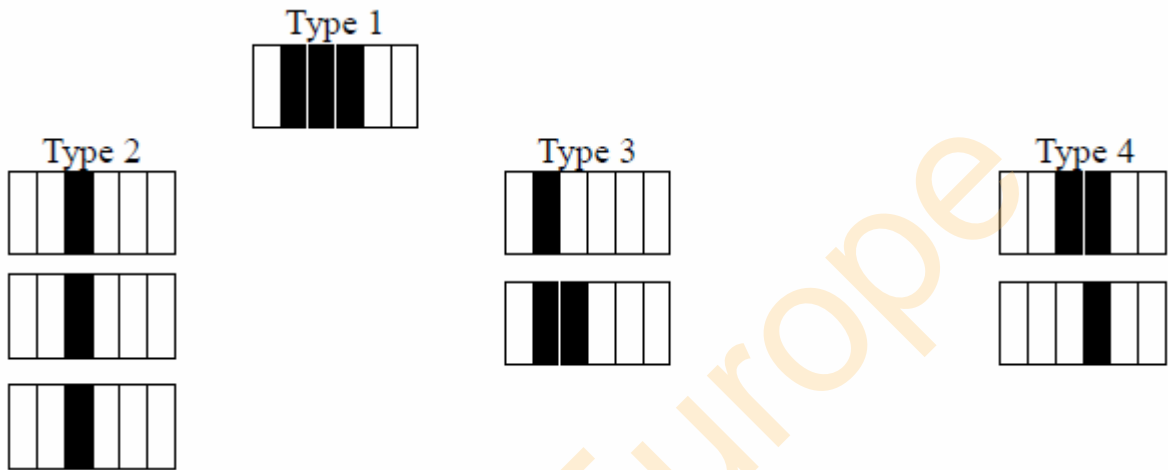

Note 11 : Distance between dot defects

Bright dot to bright dot.

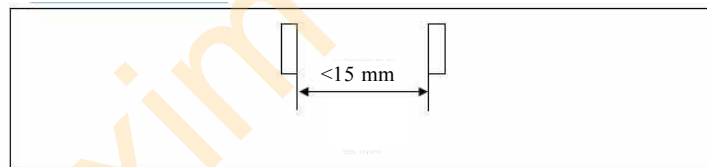

Dark dot to dark dot

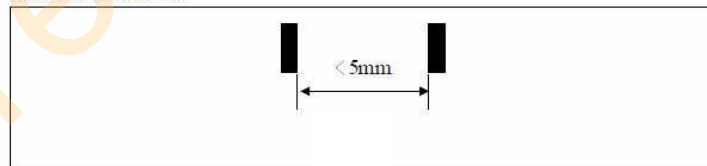

Bright dot to dark dot

