



Distributed by:



www.texim-europe.com

Product Specification

Part Name: 3.50 inch TFT Display Module

Customer Part ID:

Topovision Part ID: TVT0350AM (Mono TFT)

Ver: A

Customer:
Approved by

From: Topovision Technology Co., Ltd.
Approved by

Notes:

1. Please contact Topovision Technology Co., Ltd. before assigning your product based on this module specification
2. The information contained herein is presented merely to indicate the characteristics and performance of our products. No responsibility is assumed by Topovision Technology Co., Ltd. for any intellectual property claims or other problems that may result from application based on the module described herein.

Revision History

Rev.	Date	Contents	Written	Approved
A	2014/09/16	Preliminary Specification	Lemon	Sam

Special Notes

Note1.	

Contents

1	Introduction-----	4
2	General specification-----	5
3	Mechanical drawing-----	6
4	Absolute maximum ratings-----	7
5	Electrical characteristics-----	7
6	Backlight driving conditions -----	7
7	Optical characteristics -----	8
8	Pin Assignment -----	11
9	Block diagram -----	18
10	LCM quality criteria-----	19
11	Packing method-----	25

1. Introduction

1.1 Scope of application

This specification applies to the positive type TFT transmissive dot matrix LCD module. This LCD module should be designed for mobile phone use.

LCD specification: Dots 320xRGBx240.

As to basic specification of the driver IC, refer to the IC (SSD2119) specification and datasheet.

1.2 Structure:

Double display structure:

TFT Module + FPC +BL;

Mono LCD size for main LCD;

One bare chip with gold bump (COG) TECH;

1.3 TFT features:

Structure: TFT PANNEL+IC+FPC+BL;

Transmissive Type LCD;

320 dot-source and 240 dot-gate outputs;

White LED back light;

1.4 Applications:

Mobile phone

PSP

PDA

GPS

Etc...

2. General specification

ITEM	Standard value	UNIT
LCD Type	TFT Transmissive	---
Driver element	a-Si TFT Active matrix	
Number of Dots	320*240	Dots
Pixel Arrangement	WWW- Stripe	
Active Area	70.08 *52.56	mm
Viewing Direction	6 O'clock	
Driver IC	SSD2119	
Module Size(W*H*T)	76.9x63.9x3.1	mm
Approx. Weight	TBD	g
Back Light	White LED	
System interface	1. 8/ 9/ 16/ 18-bit 6800-series / 8080-series Parallel Interface 2. Serial Peripheral Interface (SPI) 3. 18-/6-bit RGB interface (DE, DOTCLK, HSYNC, VSYNC, DB[17:0]) 4. WSYNC interface (system interface + WSYNC)	

3. Mechanical drawing

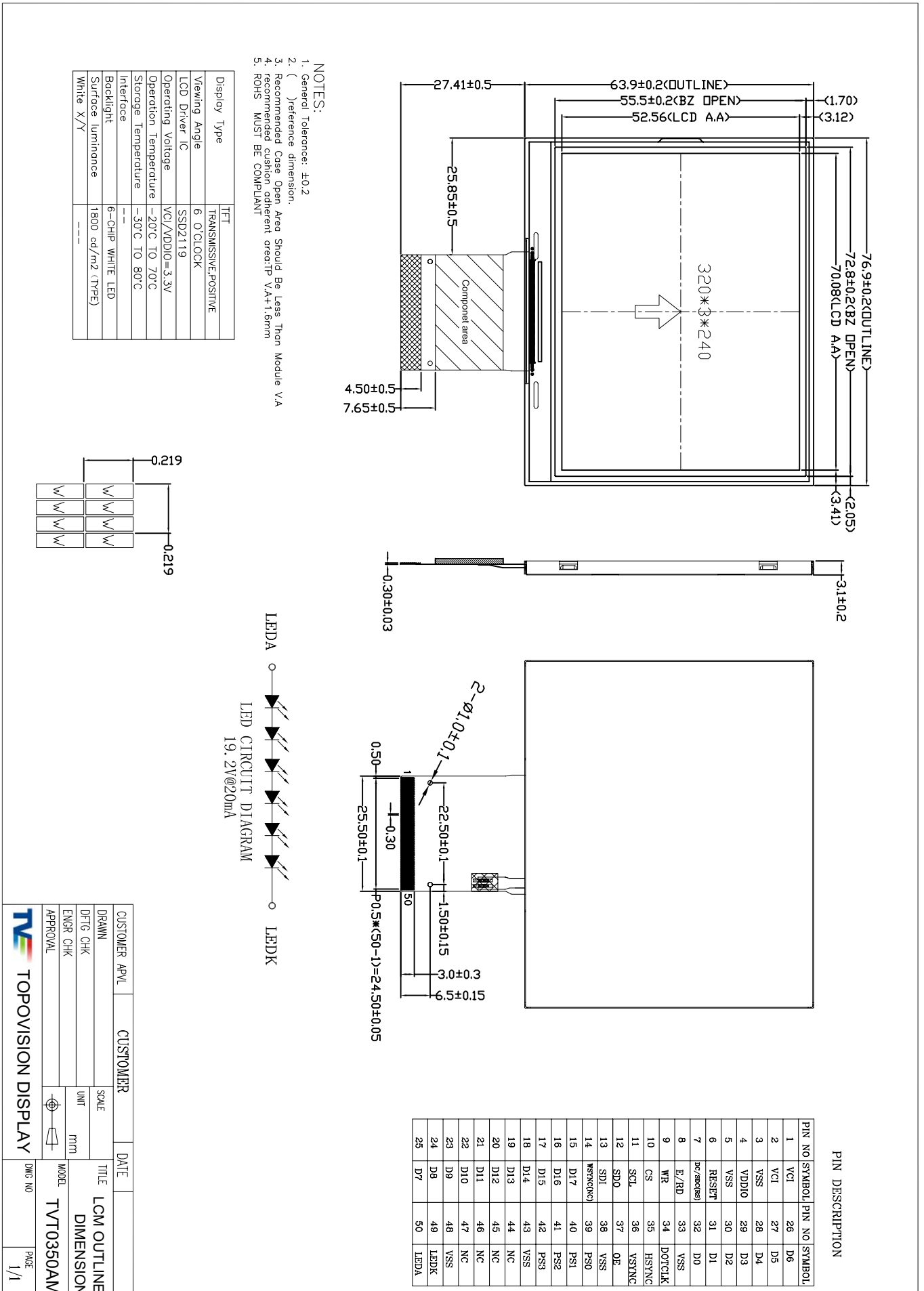

4. ABSOLUTE MAXIMUM RATINGS

Parameter	Symbol	Min	Max	Unit
Supply voltage for logic	VDDIO	-0.3	4.0	V
Supply voltage for analog	VCI	-0.5	5.0	V
Supply current (One LED)	I _{LED}		30	mA
Operating temperature	T _{OP}	-20	+70	°C
Storage temperature	T _{ST}	-30	+80	°C

5. ELECTRICAL CHARACTERISTICS

Item	Symbol	Min	Typ	Max	Unit	Applicable terminal
Supply voltage for logic	VDDIO	1.8	-	3.3	V	V _{DD}
Supply voltage for analog	VCI	2.5	3.3	3.6		
Input voltage	V _{IL}	-0.3	-	0.2 V _{CC}	V	
	V _{IH}	0.8 V _{CC}	-	V _{CC}	V	
Input leakage current	I _{LKG}	-	-	-	μA	
LED Forward voltage	V _f	3.0	3.2	3.4	V	With One LED
Input backlight current	I _{LED}	-	20	25	mA	With One LED

6. Backlight driving conditions

Item	Symbol	Values			Unit	Remark
		Min.	Typ.	Max.		
Voltage for LED backlight	V _L	18	19.2	20.4	V	
Current for LED backlight	I _L	-	20	25	mA	
LED life time	-	20,000	-	-	Hr	

7. OPTICAL CHARACTERISTICS

ITEM	SYMBOL	CONDITIONS	SPECIFICATIONS			UNIT	NOTE
			MIN.	TYP.	MAX		
Brightness	B	Viewing normal angle	-	1800	-	Cd/m ²	All left side data are based on LAIBAO's product reference only
Contrast Ratio	CR		200	300	--	--	
Response Time	Tr+Tf		--	35	50	ms	
Viewing Angle	White	X _w	--	0.32		Deg.	
		Y _w		0.39			
	Ver	θ_{y+}	-	35	--		
		θ_{y-}	-	15	--		
Hor	θ_{x+}	-	45	--			
	θ_{x-}	-	45				

Note 1 : Definition of Viewing Angle θ_x and θ_y :

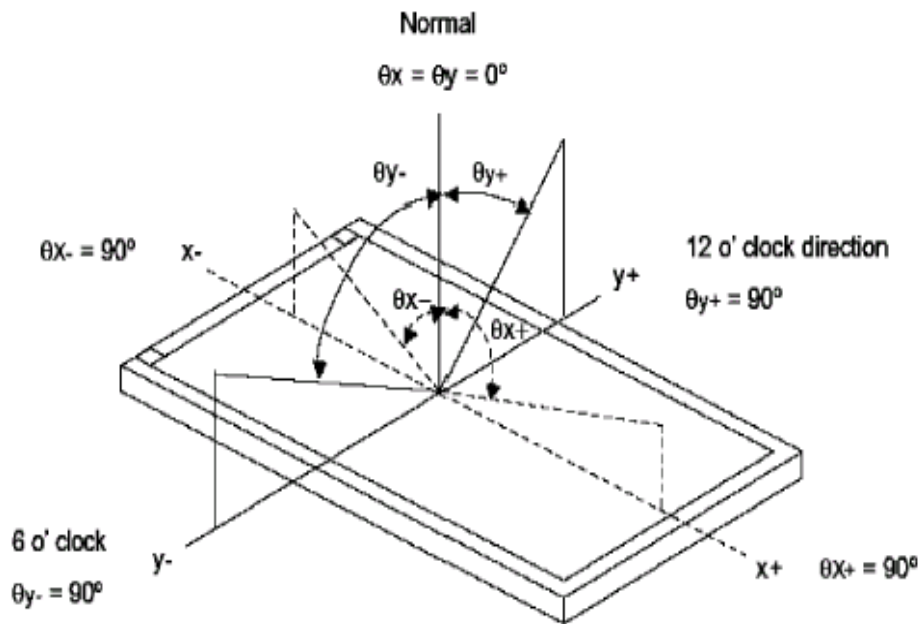

Note 2: Definition of contrast ratio CR:

$$CR = \frac{\text{Brightness of non-selected dots (white)}}{\text{Brightness of selected dots (black)}}$$

Note 3: Definition of response time (T_R , T_F)

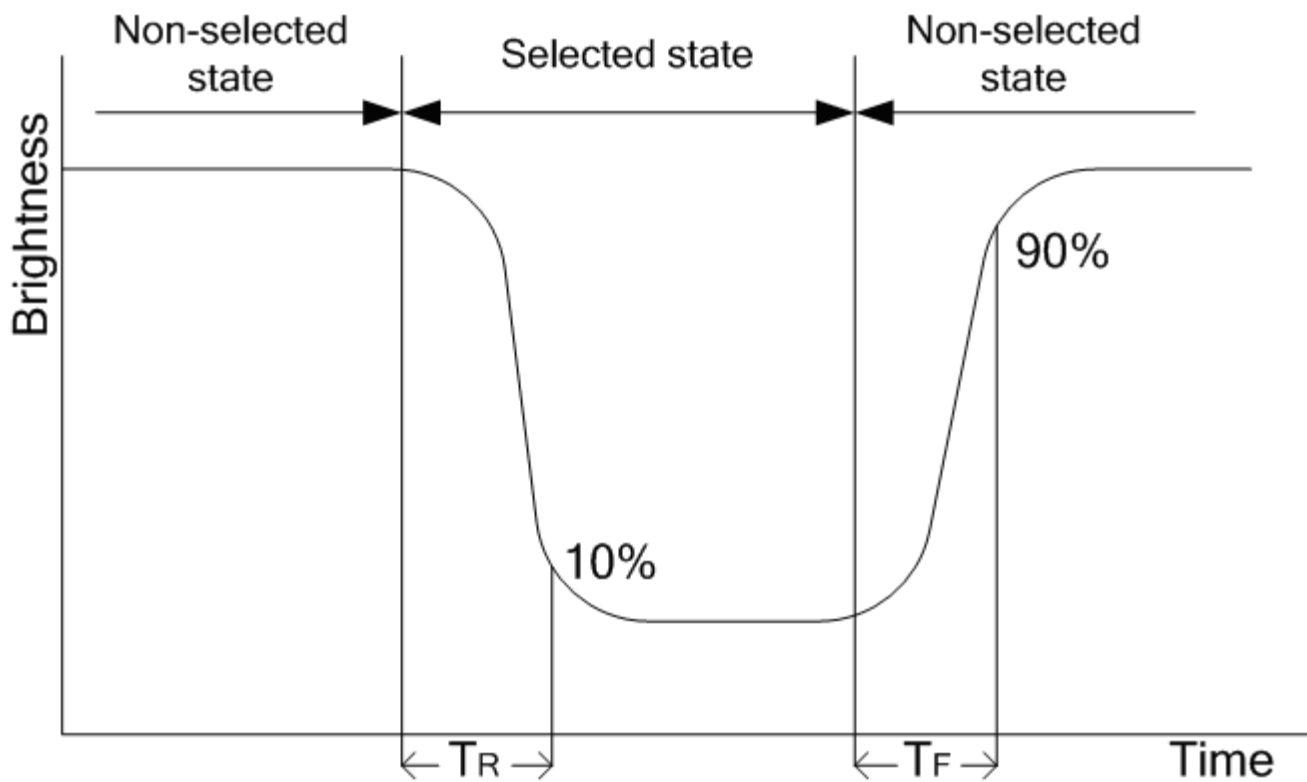

The brightness test equipment setup

20mA Field=2° (As measuring "black" image, field=2° is the best testing condition)

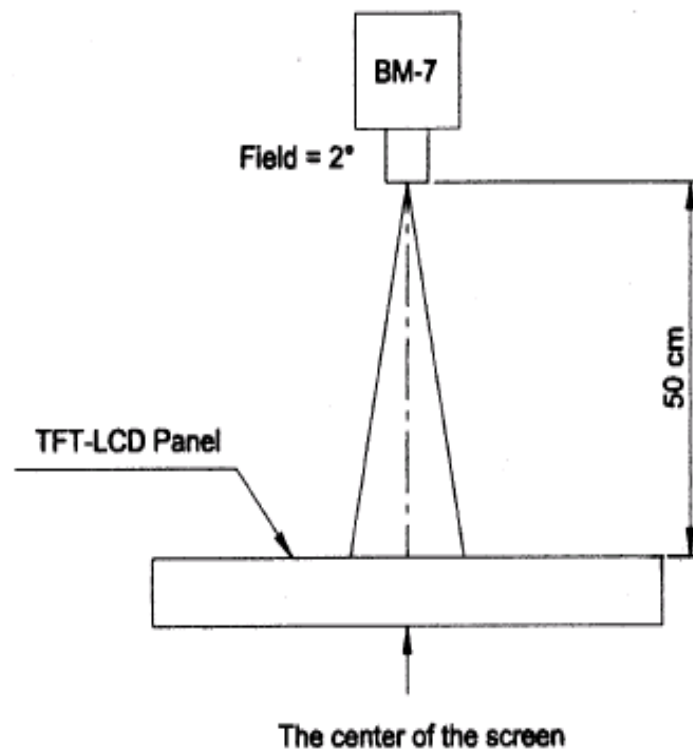

Note 4 :

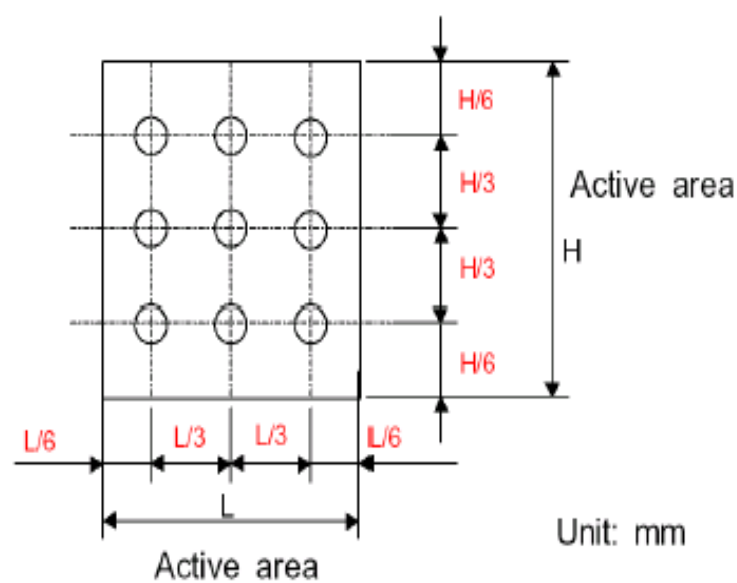

8. MCU Interface Pin Function

. Table 2: Pin assignment

Pin No.	Symbol	Description
1~2	VCI	Power supply for analog
3	VSS	Ground.
4	VDDIO	Voltage input pin for logic I/O
5	VSS	Ground.
6	RESB	System reset pin. - An active low pulse at this pin will reset the IC, Connect to VDDIO in normal operation
7	DC/SDC (RS)	A register select signal. Low: select an index or status register, High: select a control register.
8	E/ $\overline{\text{RD}}$	6800-system : E (enable signal) 8080-system : RD (read strobe signal) Serial mode : Not used and should be connected to VDDIO or Vss
9	WR	8080-system : WR (write strobe signal)
10	CS	CS : Chip select pin
11	SCL	Serial clock input
12	SDO	Data output pin in serial interface
13	SDI	Data input pin in serial interface
14	WSYNC	Ram Write Synchronization output -Leave it OPEN when not used
15~32	DB17~DB0	Data bus.
33	VSS	Ground.
34	DOTCLK	Dot-clock signal and oscillator source.
35	HSYNC	Line Synchronization input
36	VSYNC	Frame/Ram Write Synchronization input
37	OE	Display enable pin from controller.
38	VSS	Ground.
39	PS0	Refer of Table1
40	PS1	
41	PS2	
42	PS3	
43	VSS	Ground.
44~47	NC	Not Connection
48	VSS	Ground.
49	LEDK	Cathode of LED backlight.
50	LEDA	Anode of LED backlight.

Table1

PS 3	PS2	PS1	PS0	Interface Mode
0	0	0	0	16-bit 6800 parallel interface (DB1-DB8&DB10-DB17)
0	0	0	1	8-bit 6800 parallel interface (DB10-DB17)
0	0	1	0	16-bit 8080 parallel interface (DB1-DB8&DB10-DB17)
0	0	1	1	8-bit 8080 parallel interface (DB10-DB17)
0	1	0	0	9-bit generic D[17:9] (262k colour) + 3-wire SPI If 65K color, D12 shorts to D17 internally
0	1	0	1	16-bit generic (262k colour)+ 3-wire SPI
0	1	1	0	18-bit generic (262k colour)+ 3-wire SPI
0	1	1	1	6-bit generic D[17:12] (262k colour) + 3-wire SPI
1	0	0	0	18-bits 6800 parallel interface (DB0-17)
1	0	0	1	9-bits 6800 parallel interface (DB9-17)
1	0	1	0	18-bit 8080 parallel interface(DB0-17)
1	0	1	1	9-bit 8080 parallel interface (DB9-17)
1	1	1	0	3-wire SPI
1	1	1	1	4-wire SPI

8.1 Timing characteristics

8.1.1. Serial timing characteristics

Symbol	Parameter	Min	Typ	Max	Unit																														
t_{cycle}	Clock Cycle Time	77	-	-	ns																														
f_{CLK}	Serial Clock Cycle Time SPI Clock tolerance = +/- 2 ppm	-	-	15	MHz																														
t_{AS}	Register select Setup Time	4	-	-	ns																														
t_{AH}	Register select Hold Time	5	-	-	ns																														
t_{CSS}	Chip Select Setup Time	2	-	-	ns																														
t_{CSH}	Chip Select Hold Time	10	-	-	ns																														
t_{DSW}	Write Data Setup Time	5	-	-	ns </tr <tr> <td>t_{DHW}</td> <td>Write Data Hold Time</td> <td>10</td> <td>-</td> <td>-</td> <td>ns</td> </tr> <tr> <td>t_{CLKL}</td> <td>Clock Low Time</td> <td>38</td> <td>-</td> <td>-</td> <td>ns</td> </tr> <tr> <td>t_{CLKH}</td> <td>Clock High Time</td> <td>38</td> <td>-</td> <td>-</td> <td>ns</td> </tr> <tr> <td>t_{R}</td> <td>Rise time</td> <td>-</td> <td>-</td> <td>4</td> <td>ns</td> </tr> <tr> <td>t_{F}</td> <td>Fall time</td> <td>-</td> <td>-</td> <td>4</td> <td>ns</td> </tr>	t_{DHW}	Write Data Hold Time	10	-	-	ns	t_{CLKL}	Clock Low Time	38	-	-	ns	t_{CLKH}	Clock High Time	38	-	-	ns	t_{R}	Rise time	-	-	4	ns	t_{F}	Fall time	-	-	4	ns
t_{DHW}	Write Data Hold Time	10	-	-	ns																														
t_{CLKL}	Clock Low Time	38	-	-	ns																														
t_{CLKH}	Clock High Time	38	-	-	ns																														
t_{R}	Rise time	-	-	4	ns																														
t_{F}	Fall time	-	-	4	ns																														

4 wire serial timing characteristics

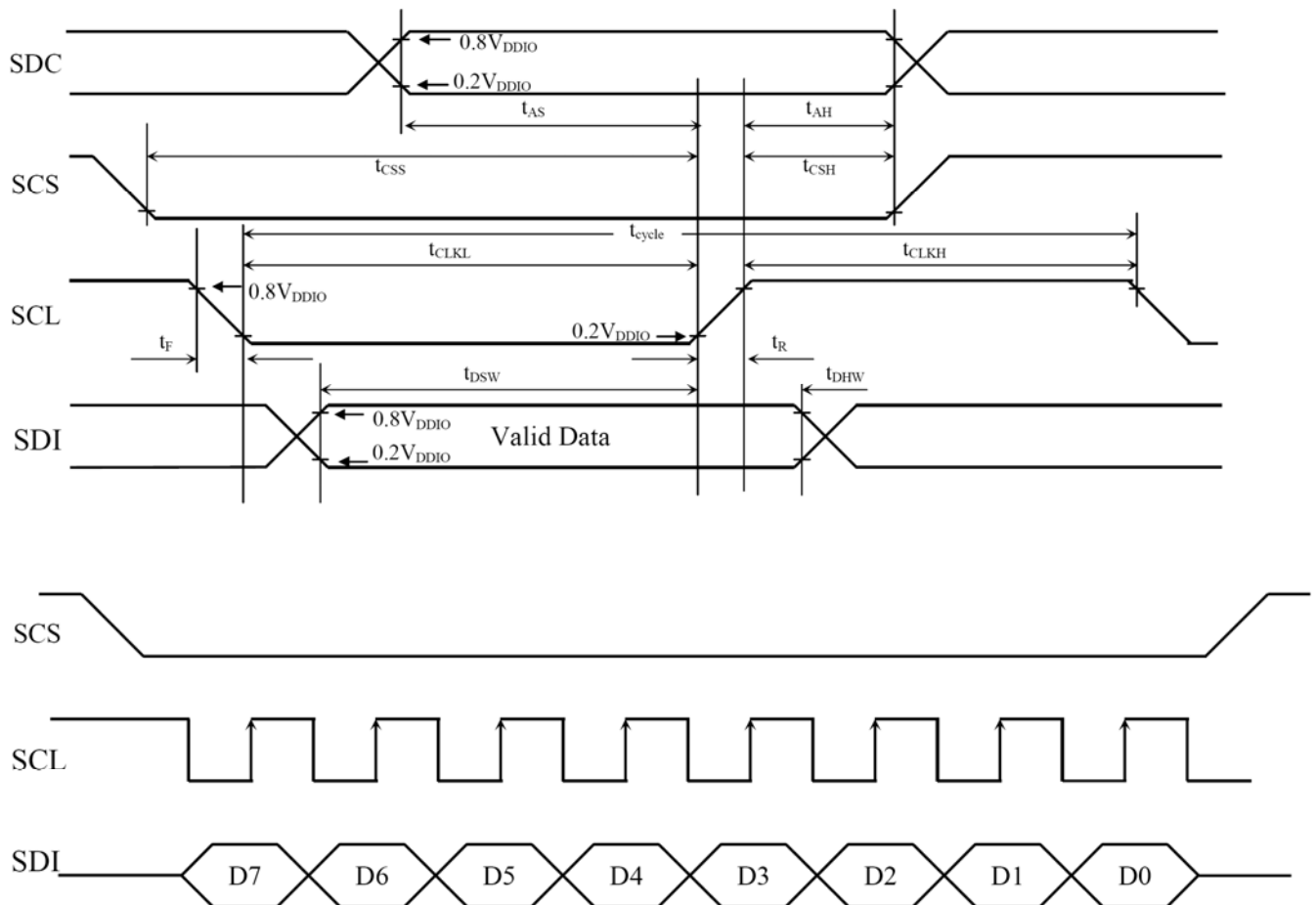

8.1.2. RGB timing characteristics

Symbol	Parameter	Min	Typ	Max	Unit
f_{DOTCLK}	DOTCLK Frequency (70Hz frame rate)	1	5.5	8.2	MHz
t_{DOTCLK}	DOTCLK Period	122	182	1000	ns
t_{VSYs}	Vertical Sync Setup Time	20	-	-	ns
t_{VSYH}	Vertical Sync Hold Time	20	-	-	ns
t_{HSYs}	Horizontal Sync Setup Time	20	-	-	ns
t_{HSYH}	Horizontal Sync Hold Time	20	-	-	ns
t_{HV}	Phase difference of Sync Signal Falling Edge	0	-	320	t_{DOTCLK}
t_{CLK}	DOTCLK Low Period	61	-	-	ns
t_{CKH}	DOTCLK High Period	61	-	-	ns
t_{DS}	Data Setup Time	25	-	-	ns
t_{DH}	Data hold Time	25	-	-	ns

Note: External clock source must be provided to DOTCLK pin of SSD2119. The driver will not operate in absence of the clocking signal.

RGB timing characteristics

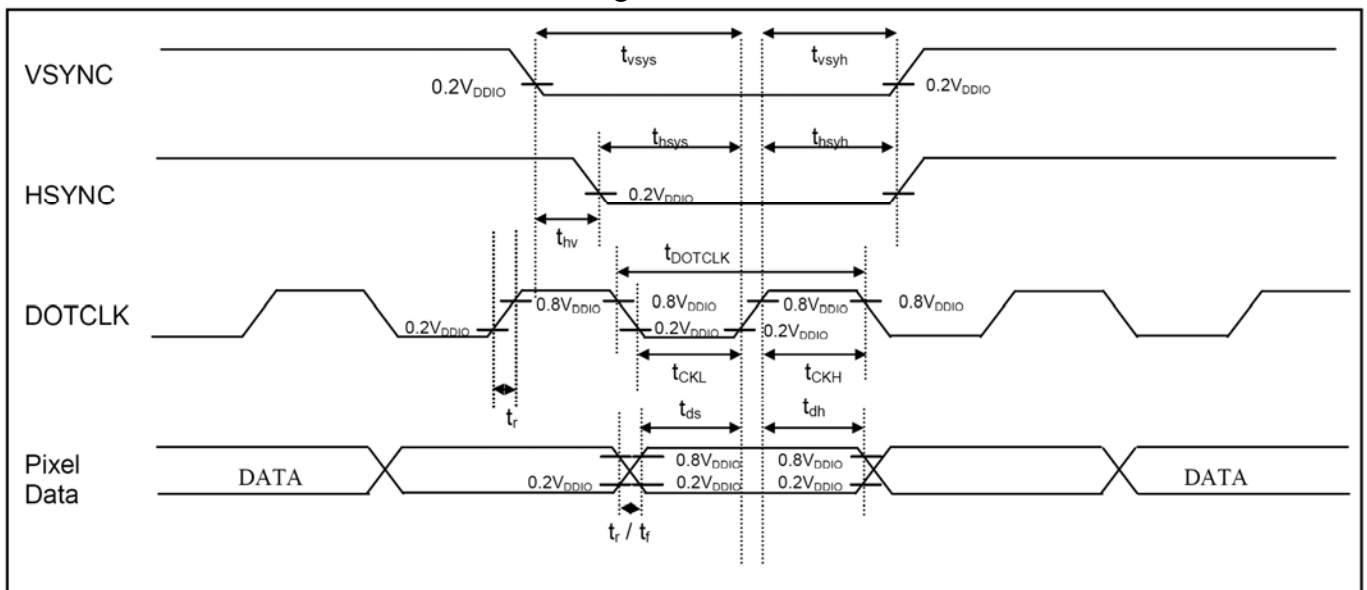

8.1.3. parallel 8080 MCU interface

Symbol	Parameter	Min	Typ	Max	Unit
t_{cycle}	Clock Cycle Time (write cycle)	75	-	-	ns
t_{cycle}	Clock Cycle Time (read cycle) (Based on $V_{OL}/V_{OH} = 0.3 \cdot V_{DDIO}/0.7 \cdot V_{DDIO}$)	450	-	-	ns
t_{AS1}	Address Setup Time between (R/\bar{W}) and D/\bar{C}	0	-	-	ns
t_{AH1}	Address Hold Time between (R/\bar{W}) and D/\bar{C}	0	-	-	ns
t_{AS2}	Address Setup Time between (R/\bar{W}) and \bar{CS}	0	-	-	ns
t_{AH2}	Address Hold Time between (R/\bar{W}) and \bar{CS}	0	-	-	ns
t_{DSW}	Data Setup Time (D0~D7, WRITE)	5	-	-	ns
t_{DHW}	Data Hold Time (D0~D7, WRITE)	5	-	-	ns
t_{ACC}	Data Access Time (D0~D7, READ)	250	-	-	ns
t_{OH}	Output Hold time (D0~D7, READ)	100	-	-	ns
PW_{CSL}	Pulse width /CS low (write cycle)	40	-	-	ns
PW_{CSH}	Pulse width /CS high (write cycle)	25	-	-	ns
PW_{CSL}	Pulse width /CS low (read cycle)	500	-	-	ns
PW_{CSH}	Pulse width /CS high (read cycle)	500	-	-	ns
t_R	Rise time	-	-	4	ns
t_F	Fall time	-	-	4	ns

parallel 8080 MCU interface timing characteristics

Write Cycle

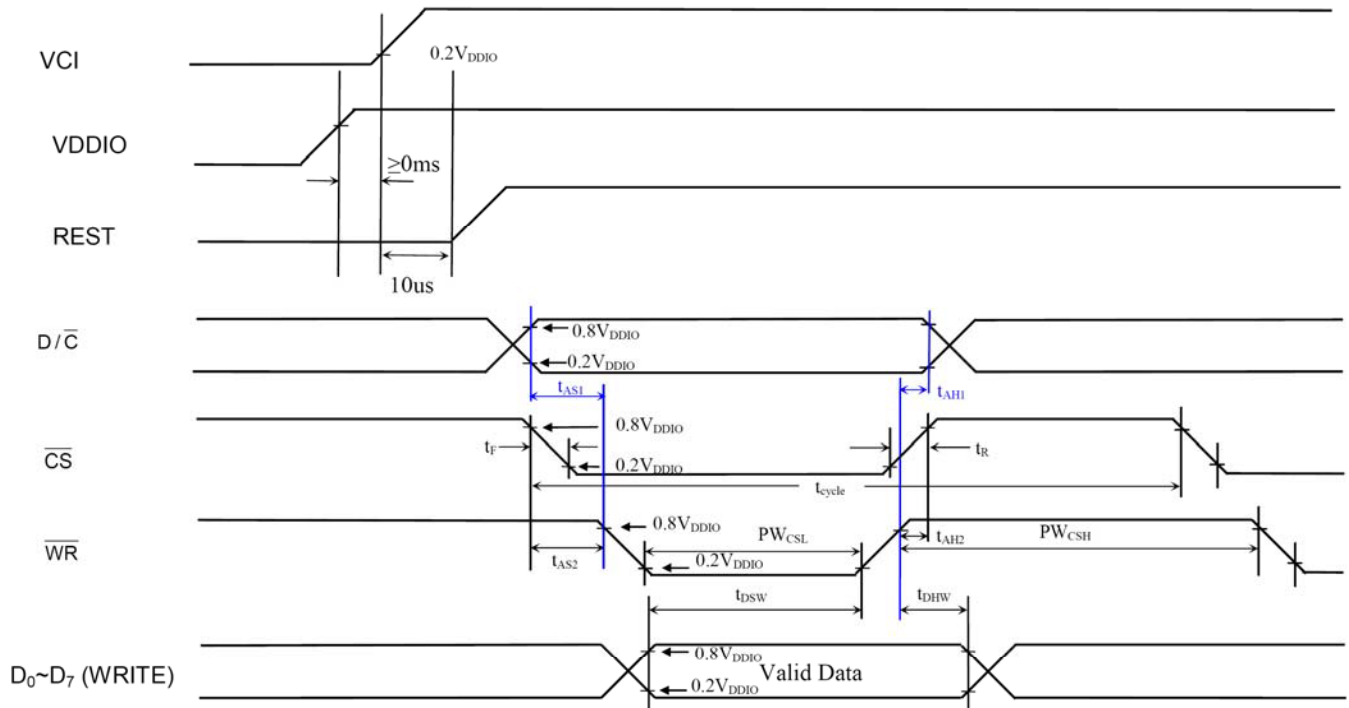

Remark: It's highly recommended that \overline{RD} remains high for the whole write cycle

Read Cycle

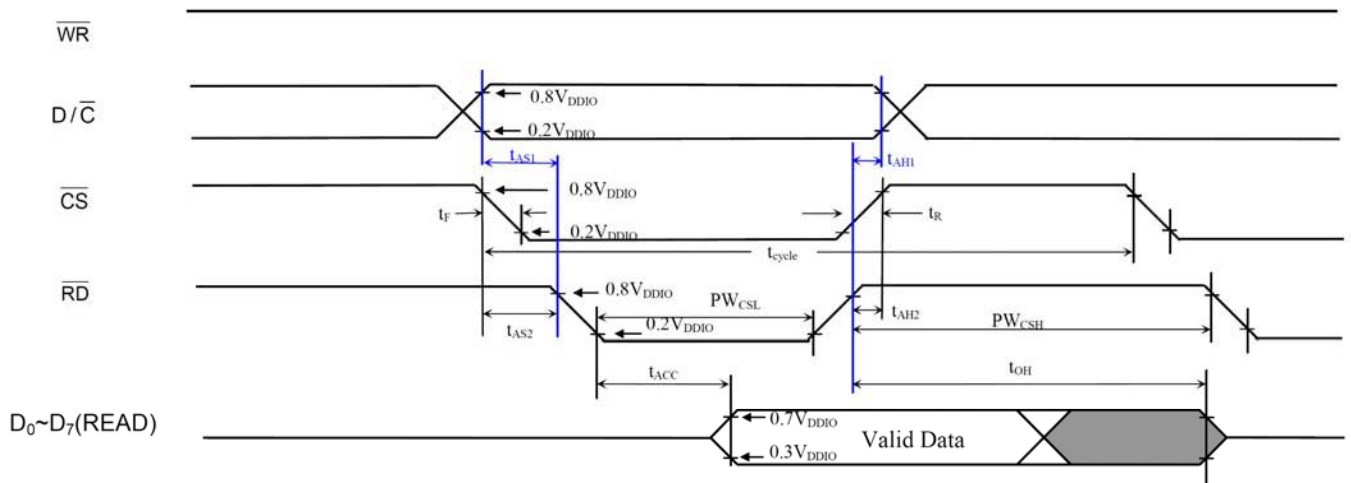

8.3.4 parallel 6800 interface

Symbol	Parameter	Min	Typ	Max	Unit
t_{cycle}	Clock Cycle Time (write cycle)	75	-	-	ns
t_{cycle}	Clock Cycle Time (read cycle) (Based on $V_{OL}/V_{OH} = 0.3 \cdot V_{DDIO}/0.7 \cdot V_{DDIO}$)	450	-	-	ns
t_{AS}	Address Setup Time (R/ \bar{W})	0	-	-	ns
t_{AH}	Address Hold Time (R/ \bar{W})	0	-	-	ns
t_{DSW}	Data Setup Time (D0~D7, WRITE)	5	-	-	ns
t_{DHW}	Data Hold Time (D0~D7, WRITE))	5	-	-	ns
t_{ACC}	Data Access Time (D0~D7, READ)	250	-	-	ns
t_{OH}	Output Hold time (D0~D7, READ)	100	-	-	ns
PW_{CSL}	Pulse width /CS low (write cycle)	40	-	-	ns
PW_{CSH}	Pulse width /CS high (write cycle)	25	-	-	ns
PW_{CSL}	Pulse width /CS low (read cycle)	500	-	-	ns
PW_{CSH}	Pulse width /CS high (read cycle)	500	-	-	ns
t_R	Rise time	-	-	4	ns
t_F	Fall time	-	-	4	ns

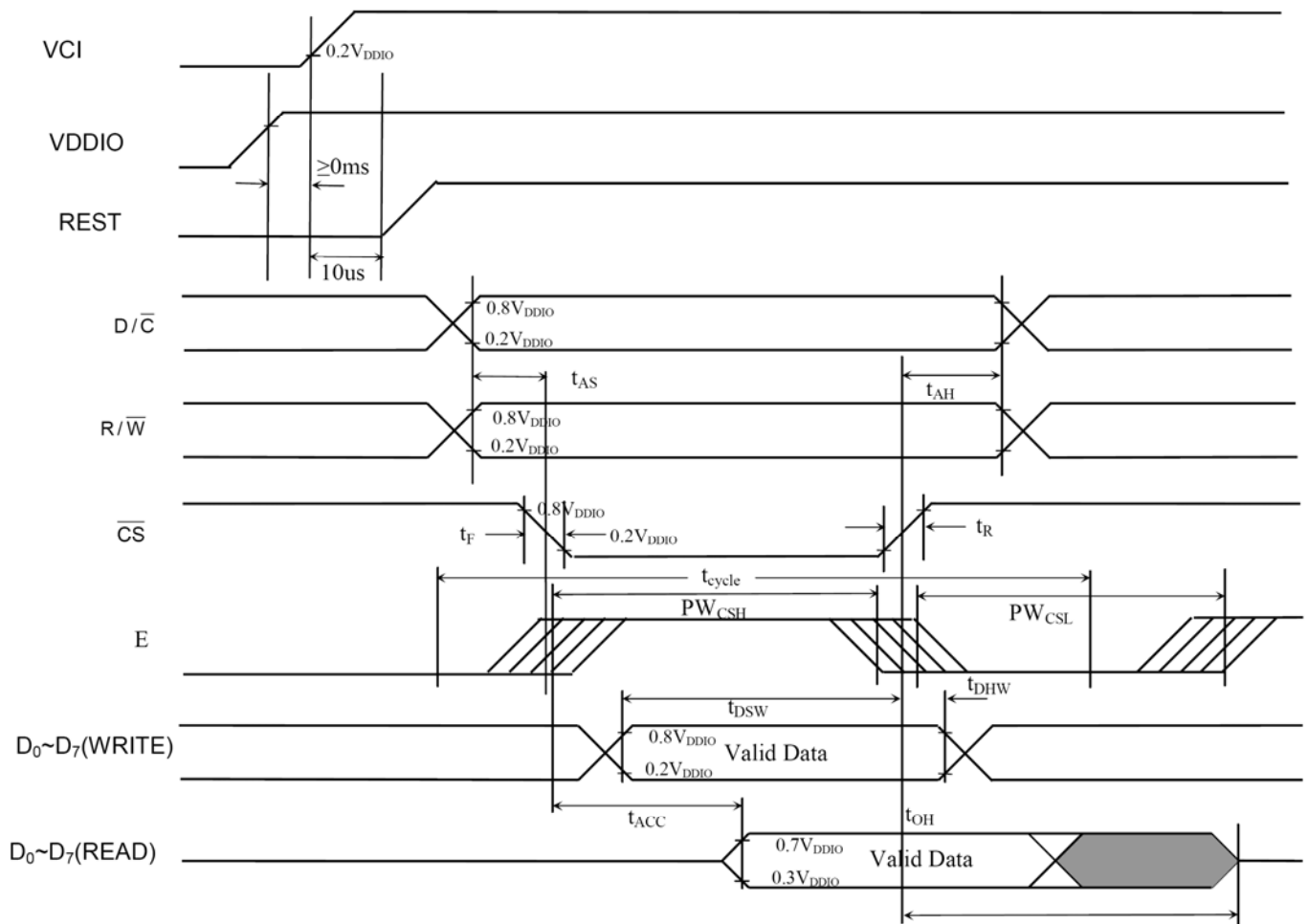

9. BLOCK DIAGRAM

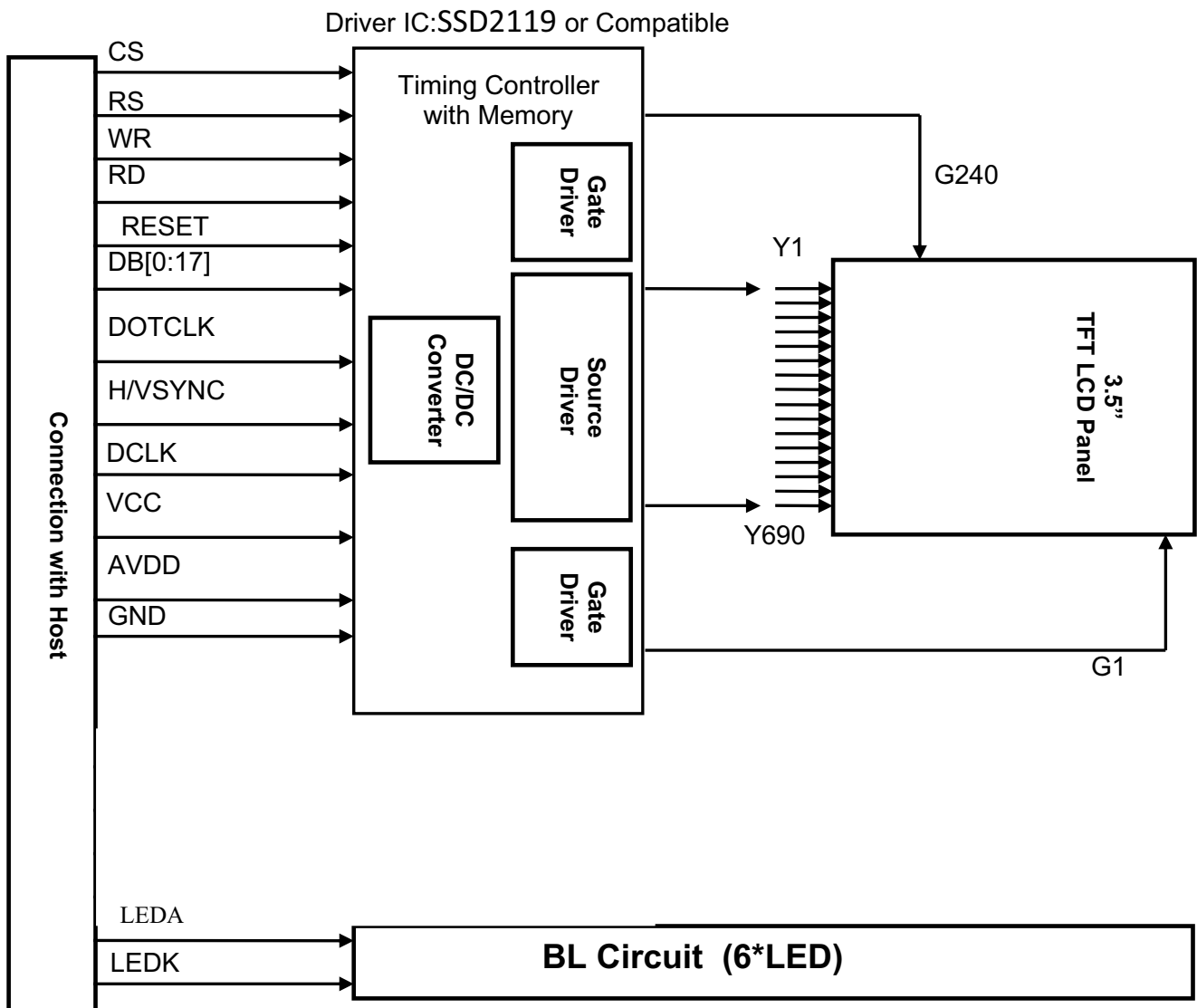

10. LCM Quality Criteria

10.1 VISUAL & FUNCTION INSPECTION STANDARD

10.1.1 Inspection conditions

Inspection performed under the following conditions is recommended.

Temperature : 25±5°C

Humidity : 65%±10%RH

Viewing Angle : Normal viewing Angle.

Illumination: Single fluorescent lamp (300 to 700Lux)

Viewing distance:30-50cm

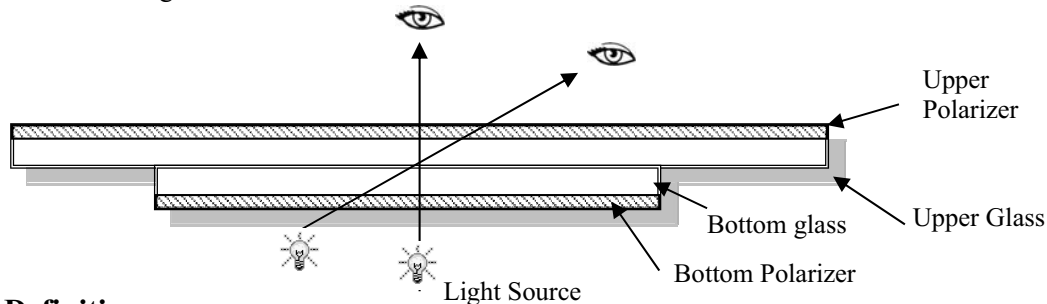

10.1.2 Definition

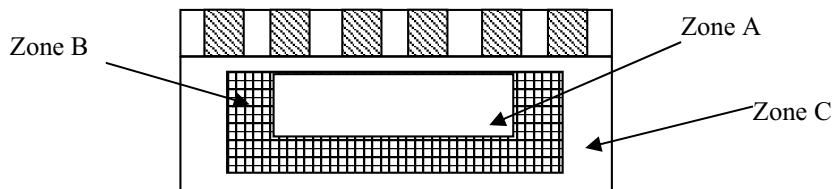

Zone A : Effective Viewing Area(Character or Digit can be seen)

Zone B : Viewing Area except Zone A

Zone C : Outside (Zone A+Zone B) which can not be seen after assembly by customer .)

Note:

As a general rule ,visual defects in Zone C can be ignored when it doesn't effect product function or appearance after assembly by customer.

10.1.3 Sampling Plan

According to GB/T 2828-2003 ; , normal inspection, Class II

AQL:

Major defect	Minor defect
0.65	1.5

LCD: Liquid Crystal Display , TP: Touch Panel , LCM: Liquid Crystal Module

No	Items to be inspected	Criteria	Classification of defects
1	Functional defects	1) No display, Open or miss line 2) Display abnormally, Short 3) Backlight no lighting, abnormal lighting. 4) TP no function	Major
2	Missing	Missing component	
3	Outline dimension	Overall outline dimension beyond the drawing is not allowed	Minor
4	Color tone	Color unevenness, refer to limited sample	
5	Soldering appearance	Good soldering , Peeling off is not allowed.	
6	LCD/Polarizer/TP	Black/White spot/line, scratch, crack, etc.	

10.1.4 Criteria (Visual)

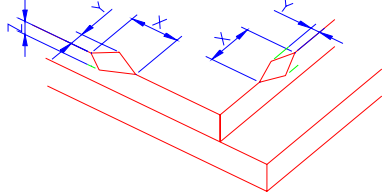
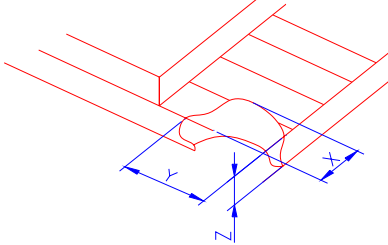
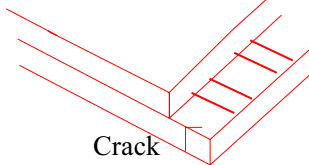
Number	Items	Criteria(mm)						
1.0 LCD Crack/Broken NOTE: X: Length Y: Width Z: Height L: Length of ITO, T: Height of LCD	(1) The edge of LCD broken	 <table border="1" data-bbox="853 568 1396 723"> <thead> <tr> <th>X</th> <th>Y</th> <th>Z</th> </tr> </thead> <tbody> <tr> <td>≤3.0mm</td> <td><Inner border line of the seal</td> <td>≤T</td> </tr> </tbody> </table>	X	Y	Z	≤3.0mm	<Inner border line of the seal	≤T
X	Y	Z						
≤3.0mm	<Inner border line of the seal	≤T						
	(2)LCD corner broken	 <table border="1" data-bbox="914 1010 1335 1077"> <thead> <tr> <th>X</th> <th>Y</th> <th>Z</th> </tr> </thead> <tbody> <tr> <td>≤3.0mm</td> <td>≤L</td> <td>≤T</td> </tr> </tbody> </table>	X	Y	Z	≤3.0mm	≤L	≤T
X	Y	Z						
≤3.0mm	≤L	≤T						
	(3) LCD crack	 <p style="text-align: center;">Crack Not allowed</p>						

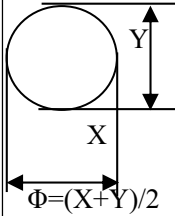
Number	Items	Criteria (mm)																									
2.0	Spot defect 	① light dot (LCD/TP/Polarizer black/white spot , light dot, pinhole, dent, stain)																									
		<table border="1"> <thead> <tr> <th rowspan="2">Zone Size (mm)</th> <th colspan="3">Acceptable Qty</th> </tr> <tr> <th>A</th> <th>B</th> <th>C</th> </tr> </thead> <tbody> <tr> <td>$\Phi \leq 0.10$</td> <td colspan="3">Ignore</td> </tr> <tr> <td>$0.10 < \Phi \leq 0.15$</td> <td colspan="3">3(distance $\geq 10\text{mm}$)</td> </tr> <tr> <td>$0.15 < \Phi \leq 0.2$</td> <td colspan="3">1</td> </tr> <tr> <td>$0.2 < \Phi$</td> <td colspan="3">0</td> </tr> </tbody> </table>	Zone Size (mm)	Acceptable Qty			A	B	C	$\Phi \leq 0.10$	Ignore			$0.10 < \Phi \leq 0.15$	3(distance $\geq 10\text{mm}$)			$0.15 < \Phi \leq 0.2$	1			$0.2 < \Phi$	0				
		Zone Size (mm)		Acceptable Qty																							
			A	B	C																						
		$\Phi \leq 0.10$	Ignore																								
		$0.10 < \Phi \leq 0.15$	3(distance $\geq 10\text{mm}$)																								
		$0.15 < \Phi \leq 0.2$	1																								
		$0.2 < \Phi$	0																								
		② Dim spot (LCD/TP/Polarizer dim dot, light leakage、dark spot)																									
		<table border="1"> <thead> <tr> <th rowspan="2">Zone Size (mm)</th> <th colspan="3">Acceptable Qty</th> </tr> <tr> <th>A</th> <th>B</th> <th>C</th> </tr> </thead> <tbody> <tr> <td>$\Phi \leq 0.1$</td> <td colspan="3">Ignore</td> </tr> <tr> <td>$0.1 < \Phi \leq 0.2$</td> <td colspan="3">2(distance $\geq 10\text{mm}$)</td> </tr> <tr> <td>$0.2 < \Phi \leq 0.3$</td> <td colspan="3">1</td> </tr> <tr> <td>$\Phi > 0.3$</td> <td colspan="3">0</td> </tr> </tbody> </table>	Zone Size (mm)	Acceptable Qty			A	B	C	$\Phi \leq 0.1$	Ignore			$0.1 < \Phi \leq 0.2$	2(distance $\geq 10\text{mm}$)			$0.2 < \Phi \leq 0.3$	1			$\Phi > 0.3$	0				
Zone Size (mm)	Acceptable Qty																										
	A	B	C																								
$\Phi \leq 0.1$	Ignore																										
$0.1 < \Phi \leq 0.2$	2(distance $\geq 10\text{mm}$)																										
$0.2 < \Phi \leq 0.3$	1																										
$\Phi > 0.3$	0																										
③ Polarizer accidented spot																											
<table border="1"> <thead> <tr> <th rowspan="2">Zone Size (mm)</th> <th colspan="3">Acceptable Qty</th> </tr> <tr> <th>A</th> <th>B</th> <th>C</th> </tr> </thead> <tbody> <tr> <td>$\Phi \leq 0.2$</td> <td colspan="3">Ignore</td> </tr> <tr> <td>$0.2 < \Phi \leq 0.5$</td> <td colspan="3">2(distance $\geq 10\text{mm}$)</td> </tr> <tr> <td>$\Phi > 0.5$</td> <td colspan="3">0</td> </tr> </tbody> </table>	Zone Size (mm)	Acceptable Qty			A	B	C	$\Phi \leq 0.2$	Ignore			$0.2 < \Phi \leq 0.5$	2(distance $\geq 10\text{mm}$)			$\Phi > 0.5$	0										
Zone Size (mm)		Acceptable Qty																									
	A	B	C																								
$\Phi \leq 0.2$	Ignore																										
$0.2 < \Phi \leq 0.5$	2(distance $\geq 10\text{mm}$)																										
$\Phi > 0.5$	0																										
Line defect (LCD/TP /Polarizer black/white line, scratch, stain)	<table border="1"> <thead> <tr> <th rowspan="2">Width(mm)</th> <th rowspan="2">Length(mm)</th> <th colspan="3">Acceptable Qty</th> </tr> <tr> <th>A</th> <th>B</th> <th>C</th> </tr> </thead> <tbody> <tr> <td>$\Phi \leq 0.03$</td> <td>Ignore</td> <td colspan="2">Ignore</td> <td rowspan="3">Ignore</td> </tr> <tr> <td>$0.03 < W \leq 0.05$</td> <td>$L \leq 3.0$</td> <td colspan="2">$N \leq 2$</td> </tr> <tr> <td>$0.05 < W \leq 0.08$</td> <td>$L \leq 2.0$</td> <td colspan="2">$N \leq 2$</td> </tr> <tr> <td>$0.08 < W$</td> <td colspan="4">Define as spot defect</td> </tr> </tbody> </table>	Width(mm)	Length(mm)	Acceptable Qty			A	B	C	$\Phi \leq 0.03$	Ignore	Ignore		Ignore	$0.03 < W \leq 0.05$	$L \leq 3.0$	$N \leq 2$		$0.05 < W \leq 0.08$	$L \leq 2.0$	$N \leq 2$		$0.08 < W$	Define as spot defect			
Width(mm)	Length(mm)			Acceptable Qty																							
		A	B	C																							
$\Phi \leq 0.03$	Ignore	Ignore		Ignore																							
$0.03 < W \leq 0.05$	$L \leq 3.0$	$N \leq 2$																									
$0.05 < W \leq 0.08$	$L \leq 2.0$	$N \leq 2$																									
$0.08 < W$	Define as spot defect																										

3.0	Polarizer Bubble	<table border="1"> <thead> <tr> <th rowspan="2">Zone Size (mm)</th> <th colspan="3">Acceptable Qty</th> </tr> <tr> <th>A</th> <th>B</th> <th>C</th> </tr> </thead> <tbody> <tr> <td>$\Phi \leq 0.2$</td> <td colspan="3">Ignore</td> </tr> <tr> <td>$0.2 < \Phi \leq 0.4$</td> <td colspan="3">2 (distance ≥ 10mm)</td> </tr> <tr> <td>$0.4 < \Phi \leq 0.6$</td> <td colspan="3">1</td> </tr> <tr> <td>$0.6 < \Phi$</td> <td colspan="3">0</td> </tr> </tbody> </table>			Zone Size (mm)	Acceptable Qty			A	B	C	$\Phi \leq 0.2$	Ignore			$0.2 < \Phi \leq 0.4$	2 (distance ≥ 10 mm)			$0.4 < \Phi \leq 0.6$	1			$0.6 < \Phi$	0			
		Zone Size (mm)	Acceptable Qty																									
			A	B	C																							
		$\Phi \leq 0.2$	Ignore																									
		$0.2 < \Phi \leq 0.4$	2 (distance ≥ 10 mm)																									
$0.4 < \Phi \leq 0.6$	1																											
$0.6 < \Phi$	0																											
4.0	SMT	According to IPC-A-610C class II standard . Function defect and missing part are major defect ,the others are minor defect.																										
5.0	TP Related	TP bubble/ accidented spot	<table border="1"> <thead> <tr> <th rowspan="2">Size Φ(mm)</th> <th colspan="3">Acceptable Qty</th> </tr> <tr> <th>A</th> <th>B</th> <th>C</th> </tr> </thead> <tbody> <tr> <td>$\Phi \leq 0.1$</td> <td colspan="3">Ignore</td> </tr> <tr> <td>$0.1 < \Phi \leq 0.2$</td> <td colspan="3">2</td> </tr> <tr> <td>$0.2 < \Phi \leq 0.3$</td> <td colspan="3">1</td> </tr> <tr> <td>$0.3 < \Phi$</td> <td colspan="3">0</td> </tr> </tbody> </table>			Size Φ (mm)	Acceptable Qty			A	B	C	$\Phi \leq 0.1$	Ignore			$0.1 < \Phi \leq 0.2$	2			$0.2 < \Phi \leq 0.3$	1			$0.3 < \Phi$	0		
			Size Φ (mm)	Acceptable Qty																								
				A	B	C																						
			$\Phi \leq 0.1$	Ignore																								
$0.1 < \Phi \leq 0.2$	2																											
$0.2 < \Phi \leq 0.3$	1																											
$0.3 < \Phi$	0																											
Assembly deflection	beyond the edge of backlight ≤ 0.15 mm																											
Newton Ring	Newton Ring area $> 1/3$ TP area NG Newton Ring area $\leq 1/3$ TP area OK																											

	TP corner broken X: length Y: width Z: height	<table border="1"> <tr> <td>X</td> <td>Y</td> <td>Z</td> </tr> <tr> <td>X≤3.0mm</td> <td>Y≤3.0mm</td> <td>Z<LCD thickness</td> </tr> </table> * Circuitry broken is not allowed.	X	Y	Z	X≤3.0mm	Y≤3.0mm	Z<LCD thickness	
	X	Y	Z						
X≤3.0mm	Y≤3.0mm	Z<LCD thickness							
TP edge broken X: length Y: width Z: height	<table border="1"> <tr> <td>X</td> <td>Y</td> <td>Z</td> </tr> <tr> <td>X≤6.0mm</td> <td>Y≤2.0mm</td> <td>Z<LCD thickness</td> </tr> </table> * Circuitry broken is not allowed.	X	Y	Z	X≤6.0mm	Y≤2.0mm	Z<LCD thickness		
X	Y	Z							
X≤6.0mm	Y≤2.0mm	Z<LCD thickness							

Criteria (functional items)

Number	Items	Criteria (mm)
1	No display	Not allowed
2	Missing segment	Not allowed
3	Short	Not allowed
4	Backlight no lighting	Not allowed
5	TP no function	Not allowed

10.2 RELIABILITY TEST

NO	ITEM	CONDTTION	STANDARD
1	High Temp. Storage	80°C, 240 hours	1. Functional test is OK. Missing Segment, short, unclear segment, non-display, display abnormally and liquid crystal leak are un-allowed. 2. No low temperature bubbles, end seal loose and fall, frame rainbow.
2	Low Temp. Storage	-30°C, 240 hours	
3	High Temp. Operation	70°C, 240 hours	
4	Low Temp. Operation	-20°C, 240 hours	
5	High temperature and high Humidity storage	40°C,90%RH , 240 hours	
6	Thermal and cold shock	Static state, -20°C (30 Min) ~70°C (30 Min) ~-20°C (30Min) , packaging, 10 cycles	1. Function test is OK. 2. No glass crack, chipped glass, end seal loose and fall, epoxy frame crack and so on. 3. No structure loose and fall.
7	Vibration test	Packaging, Frequency : 10-55Hz Amplitude : 1.0mm, Each direction on X,Y axe 0.5 heure, circle 2 hours	
8	Dropping test	Pack products into the carton box. Drop it from 80cm height to ground. Once for each side of the carton	

NOTE:

10.2.1 The reliability items will be fully performed in new sample qualification,

10.2.2 The reliability status will be tested as monitor during mass production. Individual reliability test shall be performed by lot , Moreover, the individual reliability item shall be decided according to reliability plan.

- 10.2.3 All samples are inspected after keeping in the room with normal temperature and humidity for 2 hours or above.
- 10.2.4 Vibration test: It is not necessary to test for those products without assembly frame , back light ,PCB and so on.
- 10.2.5 Dropping test : It is necessary for affirming new package.
- 10.2.6 For the high temperature and high humidity test, pure water of over 10 MΩ.cm should be used.
- 10.2.7 Each test item applies for test LCM only once .Then tested LCM cannot be used again in any other test item.
- 10.2.8 The quantity of LCM examination for each test item is 5pcs to 10pcs.

10.3 Safety instructions

- 10.3.1 If the LCD panel breaks, be careful not to get any liquid crystal substance in your mouth.
- 10.3.2 If the liquid crystal substance touches your skin or clothes, please wash it off immediately by using soap and water.

10.4 Handling Precautions

- 10.4.1 Avoid static electricity damaging the LSI.
- 10.4.2 Do not remove the panel or frame from the module .
- 10.4.3 The polarizing plate of the display is very fragile . So, please handle it very carefully.
- 10.4.4 Do not wipe the polarizing plate with a dry cloth, as it may easily scratch the surface of the plate.
- 10.4.5 The color tone of display and background of LCM has the possibility to be changed in the storage temperature range.
- 10.4.6 Pay attention to the working environment, as the element may be destroyed by static electricity.
- Be sure to ground human body and electric appliance during work.
 - Avoid working in a dry environment to minimize the generations of static electricity.
 - Static electricity may be generated when the protective film is fast peeled off.
- 10.4.7 When soldering the terminal of LCM, make certain the AC power source of soldering iron does not leak.
- 10.4.8 If the display surface becomes contaminated ,breathe on the surface and gently wipe it with a soft-dry- clean cloth .If it is heavily contaminated ,moisten cloth with the following solvent(ex:Ethyl alcohol).Solvents other than those above-mentioned may damage the polarizer(Especially ,do not use them .ex: Warter / Ketone)

10.5 Operation instructions

- 10.5.1 It is recommended to drive the LCD within the specified voltage limits, try to adjust the operating voltage for the optimal contrast, the color and contrast of LCD panel will varies at different temperature.
- 10.5.2 Response time is greatly delayed at low operating temperature range. However, this does not mean the LCD will be out of the order, It will recover when it returns to the specified temperature range.
- 10.5.3 If the display area is pushed hard during operation, the display will become abnormal.
- 10.5.4 Do not operate the LCD at the environments over the specified conditions, this may cause damage on the LCD and shorten the lifetime.

10.6 Storage instructions:

- 10.6.1 Store LCDs in a sealed polyethylene bag.
- 10.6.2 Store LCDs in a dark place, Do not expose to sunlight or fluorescent light. Keep the temperature between 0°C and 35°C.

10.6.3 Avoid the polarizer touch any other object, (It is recommended to store them in the container in which they were shipped.)

10.7 Limited Warranty

- 10.7.1 will replace or repair any of its LCD modules, which are found to be defective, when inspected in accordance with LCM acceptance standards (copies available upon request) for a period of 12 months from ink- print date on product
- 10.7.2 Any defects must be returned to within 60 days since ship-out. Confirmation of such date shall be based on freight documents. The warranty liability of wasam limited to repair and/or replacement on defects above (7.1,7.2)
- 10.7.3 No warranty can be granted if the precautions stated above have been disregarded. The typical samples are as below:
- LCD glass crack/break
 - PCB outlet is damaged or modified.
 - PCB conductors damaged.
 - Circuit modified with by grinding, engraving or painting varnish.

--FPC crack

10.7.4 Modules must be returned with sufficient description of the failures or defects. Any connectors or cable installed by the customer must be removed completely without damaging the PCB outlet, conductors and terminals. Modules must be packed with the container in which they were shipped.



11. Packing method

-----TBD