



**Winstar Display Co., LTD**

**華凌光電股份有限公司**

WEB: <http://www.winstar.com.tw>

E-mail: [winstar@winstar.com.tw](mailto:winstar@winstar.com.tw)



## SPECIFICATION

**CUSTOMER :** \_\_\_\_\_

**MODULE NO.:** WF35PTIBCDBNO#

<p><b>APPROVED BY:</b> ( FOR CUSTOMER USE ONLY )</p>	<p><b>PCB VERSION:</b> _____ <b>DATA:</b> _____</p>
--	---

SALES BY	APPROVED BY	CHECKED BY	PREPARED BY
			葉虹蘭
<b>ISSUED DATE: 2014/11/20</b>			

TFT Display Inspection Specification: <http://www.winstar.com.tw/service.php>

**RECORDS OF REVISION**

DOC. FIRST ISSUE

VERSION	DATE	REVISED PAGE NO.	SUMMARY
0	2013/09/26		First issue
A	2014/06/03		Modify Package Specification.
B	2014/11/20		Add size & Surface. Modify Module dimension& Block Diagram& Static electricity test.

# Contents

1.Module Classification Information

2.Summary

3.General Specification

4.Absolute Maximum Ratings

5.Electrical Characteristics

6.DC Characteristics

7.AC Characteristics

8.Optical Characteristics

9.Interface

10.Block Diagram

11.Reliability

12.Contour Drawing

13.Package Specification

14.Initial Code For Reference

# 1.Module Classification Information

W F 35 P T I B C D B N 0 #  
 ① ② ③ ④ ⑤ ⑥ ⑦ ⑧ ⑨ ⑩ ⑪ ⑫ ⑬

①	Brand : WINSTAR DISPLAY CORPORATION						
②	Display Type : F→TFT Type, J→Custom TFT						
③	Display Size : 3.5" TFT						
④	Model serials no.						
⑤	Backlight Type :	F→CCFL, White S→LED, High Light White			T→LED, White		
⑥	LCD Polarize Type/ Temperature range/ Gray Scale Inversion Direction	C→Transmissive, N. T, 6:00 ; I→Transmissive, W. T, 6:00 F→Transmissive, N.T,12:00 ; L→Transmissive, W.T,12:00 Z→Transmissive, W.T, Wide Viewing Angle for O-FILM Y→Transmissive, W.T, Wide View					
⑦	A : TFT LCD B : TFT+FR+CONTROL BOARD C : TFT+FR+A/D BOARD D : TFT+FR+A/D BOARD+CONTROL BOARD E : TFT+FR+POWER BOARD F : TFT+CONTROL BOARD			G : TFT+FR H : TFT+D/V BOARD I : TFT+FR+D/V BOARD J : TFT+POWER BD			
⑧	Solution:						
	A: 128160	B:320234	C:320240	D:480234	E:480272	F: 640480	G: 800480
	H:1024600	I:320480	J:240320	K:800600	L:240400	M :1024768	P :1280800
⑨	D: Digital L : LVDS						
⑩	Interface : N : without control board A : 8Bit B : 16Bit						
⑪	TS : N : Without TS T : resistive touch panel C : capacitive touch panel						
⑫	Version						
⑬	Special Code	#:Fit in with ROHS directive regulations					

## **2.Summary**

This technical specification applies to 3.45' color TFT-LCD panel. The 3.45' color TFT-LCD panel is designed for camcorder, digital camera application and other electronic products which require high quality flat panel displays. This module follows RoHS.

### 3. General Specifications

Item	Dimension	Unit
Size	3.5	inch
Dot Matrix	320 x RGB x 240	dots
Module dimension	93.5 x 66.44 x 8.6	mm
Active area	70.08 x 52.56	mm
Dot pitch	0.073 x 0.219	mm
LCD type	TFT, Normally White, Transmissive	
View Direction	12 o'clock	
Gray Scale Inversion Direction	6 o'clock	
Backlight Type	LED ,Normally White	
Controller IC	RA8875	
Interface	Digital 8080 family MPU	
With /Without TP	Without TP	
Surface	Anti-Glare	

\*Color tone slight changed by temperature and driving voltage.

# 4. Absolute Maximum Ratings

Item	Symbol	Min	Typ	Max	Unit
Operating Temperature	TOP	-20	—	+70	°C
Storage Temperature	TST	-30	—	+80	°C

Note: Device is subject to be damaged permanently if stresses beyond those absolute maximum ratings listed above

- Temp.  $\leq 60^{\circ}\text{C}$ , 90% RH MAX. Temp.  $> 60^{\circ}\text{C}$ , Absolute humidity shall be less than 90% RH at  $60^{\circ}\text{C}$

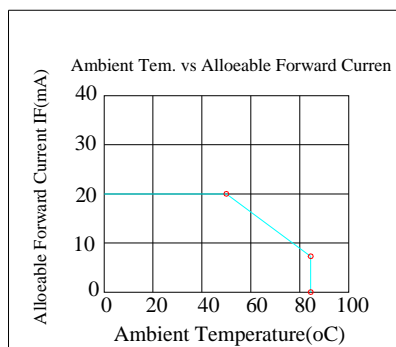

## 5. Electrical Characteristics

### 5.1. Operating conditions: (CON2.Pin1=GND, Pin2=VDD)

Item	Symbol	Condition	Min	Typ	Max	Unit	Remark
Supply Voltage For LCM	VDD	-	3.0	3.3	3.6	V	-
Supply Current For LCM	IDD	-	-	50	75	mA	Note1
Power Consumption		-	-	165	270	mW	-

Note 1 : This value is test for VDD only Ta = 25 °C

### 5.2. LED driving conditions (CON2. Pin33,34=VLED-, Pin35,36=VLED+)

Parameter	Symbol	Min.	Typ.	Max.	Unit	Remark
Operation Current For LED Driver	IVLED	-	-	75	mA	Note 1
Power Consumption	-	-	-	375	mW	VLED=5V
Supply Voltage For LED Driver	VLED+	3.3	-	5	V	Note 1
LED Life Time	-	-	50,000	-	Hr	Note 2,3,4

Note 1 : Power supply the back light IC specification

Note 2 : Ta = 25 °C

Note 3 : Brightness to be decreased to 50% of the initial value

Note 4 : The single LED lamp case



## **6.DC CHARATERISTICS**

Parameter	Symbol	Rating			Unit	Condition
		Min	Typ	Max		
Low level input voltage	VIL	GND	-	0.2 VDD	V	
High level input voltage	VIH	0.8 VDD	-	VDD	V	

# 7.AC Characteristics

## 7.1. 8080 Mode

The following timing charts are used to describe the timing specification of the standard 8080 interfaces.

## 7.2. 8080 Mode Write Cycle

Symbol	Parameter	Rating		Unit	Symbol
		Min.	Max.		
tCYC8	Cycle time	50	-	ns	tc is one system clock period: tc = 1/SYS_CLK
tCC8	Strobe Pulse width	20	-	ns	
tAS8	Address setup time	0	-	ns	
tAH8	Address hold time	10	-	ns	
tDS8	Data setup time	20	-	ns	
tDH8	Data hold time	10	-	ns	
tACC8	Data output access time	0	20	ns	
tOH8	Data output hold time	0	20	ns	

8080 – 8/16-bit interface

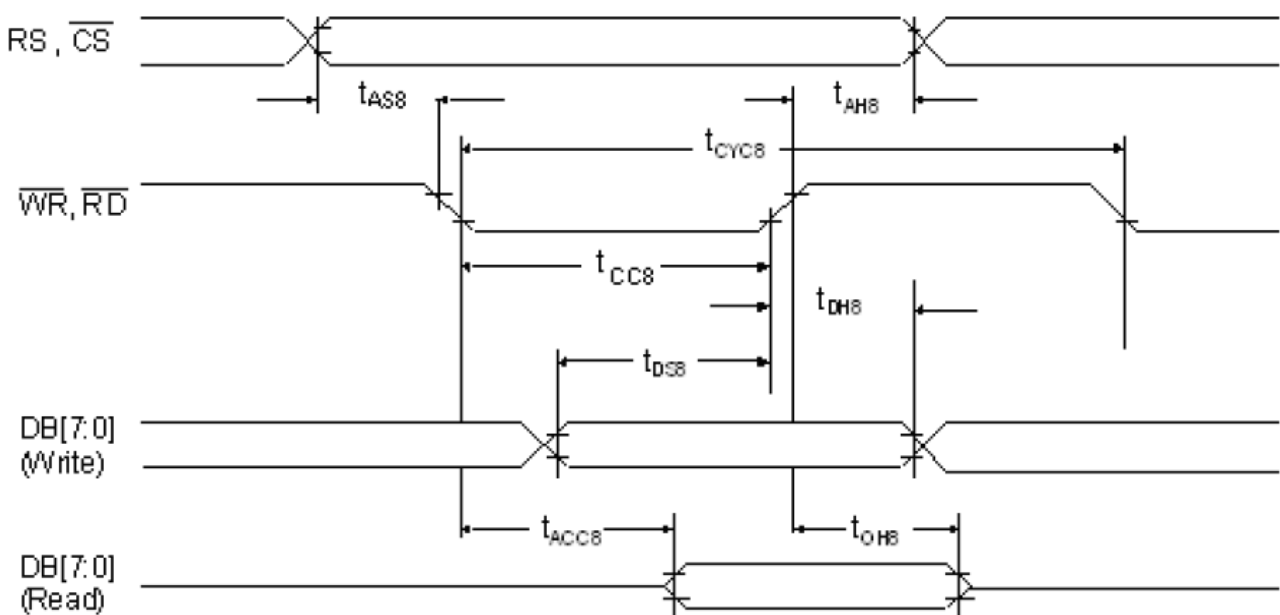

The data bus width of RA8875 can be selected to 8-bit/16-bit by setting the Bit [1:0] of SYSR. When Bit [1:0] of SYSR is cleared to “00”, then the data bus is 8-bit. If Bit [1:0] of SYSR is set to “11”, then the data transition is set as 16-bit.

### 7.3. Pixel Data Format

#### 16-bit mode color



65K colors 16-bit

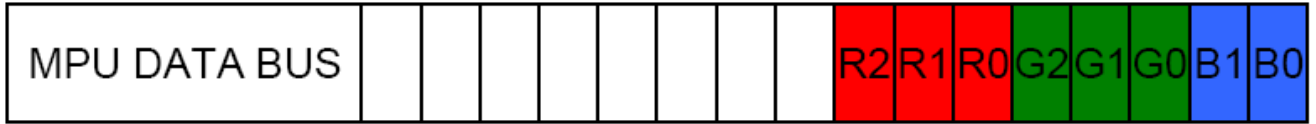

256 colors 16-bit

#### 8-bit mode color

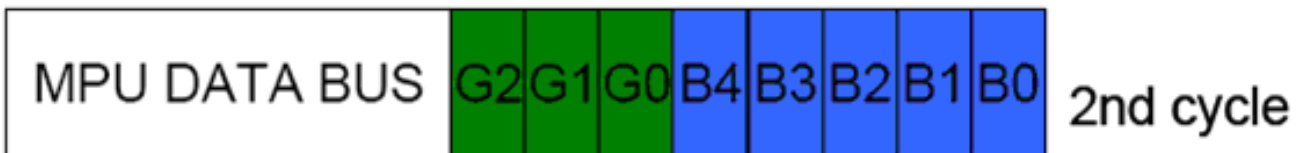

65K colors 8-bit



256 colors 8-bit

# 8. Optical Characteristics

Item	Symbol	Condition.	Min	Typ.	Max.	Unit	Remark	
Response time	Tr	$\theta = 0^\circ$ 、 $\Phi = 0^\circ$	-	10	-	ms	Note 3,5	
	Tf		-	15	-	ms		
Contrast ratio	CR	At optimized viewing angle	300	350	-	-	Note 4,5	
Color Chromaticity	White	$\theta = 0^\circ$ 、 $\Phi = 0^\circ$	0.26	0.31	0.36	-	Note 2,6,7	
			0.28	0.33	0.38	-		
Viewing angle (Gray Scale Inversion Direction)	Hor.	$CR \geq 10$	$\Theta_R$	-	55	-	Deg	Note 1
			$\Theta_L$	-	55	-		
	Ver.		$\Phi_T$	-	45	-		
			$\Phi_B$	-	50	-		
Brightness	-	-	350	420	-	cd/m <sup>2</sup>	Center of display	

Ta=25±2°C, VLED=3.3V

Note 1: Definition of viewing angle range

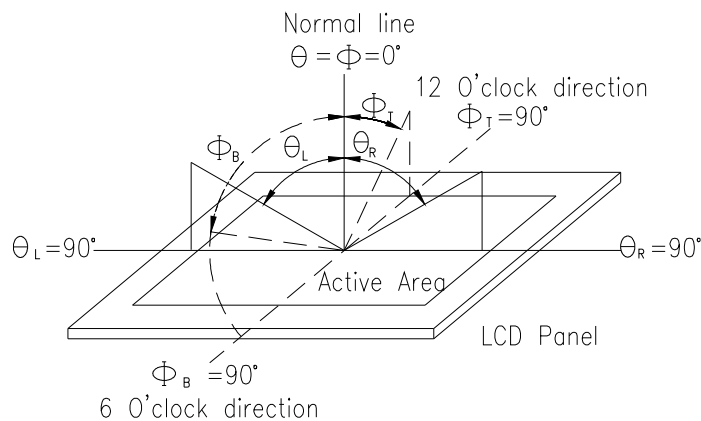

Fig. 8.1. Definition of viewing angle

Note 2: Test equipment setup:

After stabilizing and leaving the panel alone at a driven temperature for 10 minutes, the measurement should be executed. Measurement should be executed in a stable, windless, and dark room. Optical specifications are measured by Topcon BM-7 or BM-5 luminance meter 1.0° field of view at a distance of 50cm and normal direction.

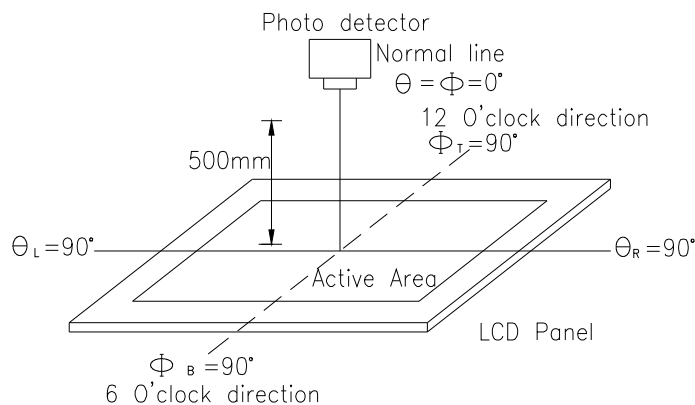
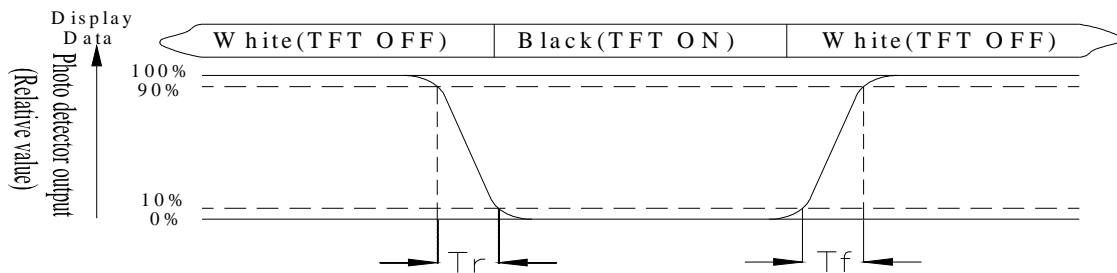

Fig. 8.2. Optical measurement system setup

Note 3: Definition of Response time:

The response time is defined as the LCD optical switching time interval between “White” state and “Black” state. Rise time,  $T_r$ , is the time between photo detector output intensity changed from 90% to 10%. And fall time,  $T_f$ , is the time between photo detector output intensity changed from 10% to 90%.



Note 4: Definition of contrast ratio:

The contrast ratio is defined as the following expression.

$$\text{Contrast ratio (CR)} = \frac{\text{Luminance measured when LCD on the "White" state}}{\text{Luminance measured when LCD on the "Black" state}}$$

Note 5: White  $V_i = V_{i50} \pm 1.5V$

Black  $V_i = V_{i50} \pm 2.0V$

“±” means that the analog input signal swings in phase with VCOM signal.

“±” means that the analog input signal swings out of phase with VCOM signal.

The 100% transmission is defined as the transmission of LCD panel when all the input terminals of module are electrically opened.

Note 6: Definition of color chromaticity (CIE 1931)

Color coordinates measured at the center point of LCD

Note 7: Measured at the center area of the panel when all the input terminals of LCD panel are electrically opened.

# 9.Interface

## 9.1. LCM PIN Definition (CON2)

Pin	Symbol	Function	Remark
1	GND	System ground	
2	VDD	Power Supply : +3.3V	
3	NC	No connect	
4	RS	Data/Command select	
5	WR	Write strobe signal	
6	RD	Read strobe signal	
7~22	DB0~DB15	Data bus	
23	WAIT	Wait Signal Output(H:active)	
24	NC	No connect	
25	CS	Chip select	
26	RST	Hardware reset	
27~32	NC	No connect	
33~34	VLED-	Power for LED backlight cathode	
35~36	VLED+	Power for LED backlight anode	

# 10. Block Diagram

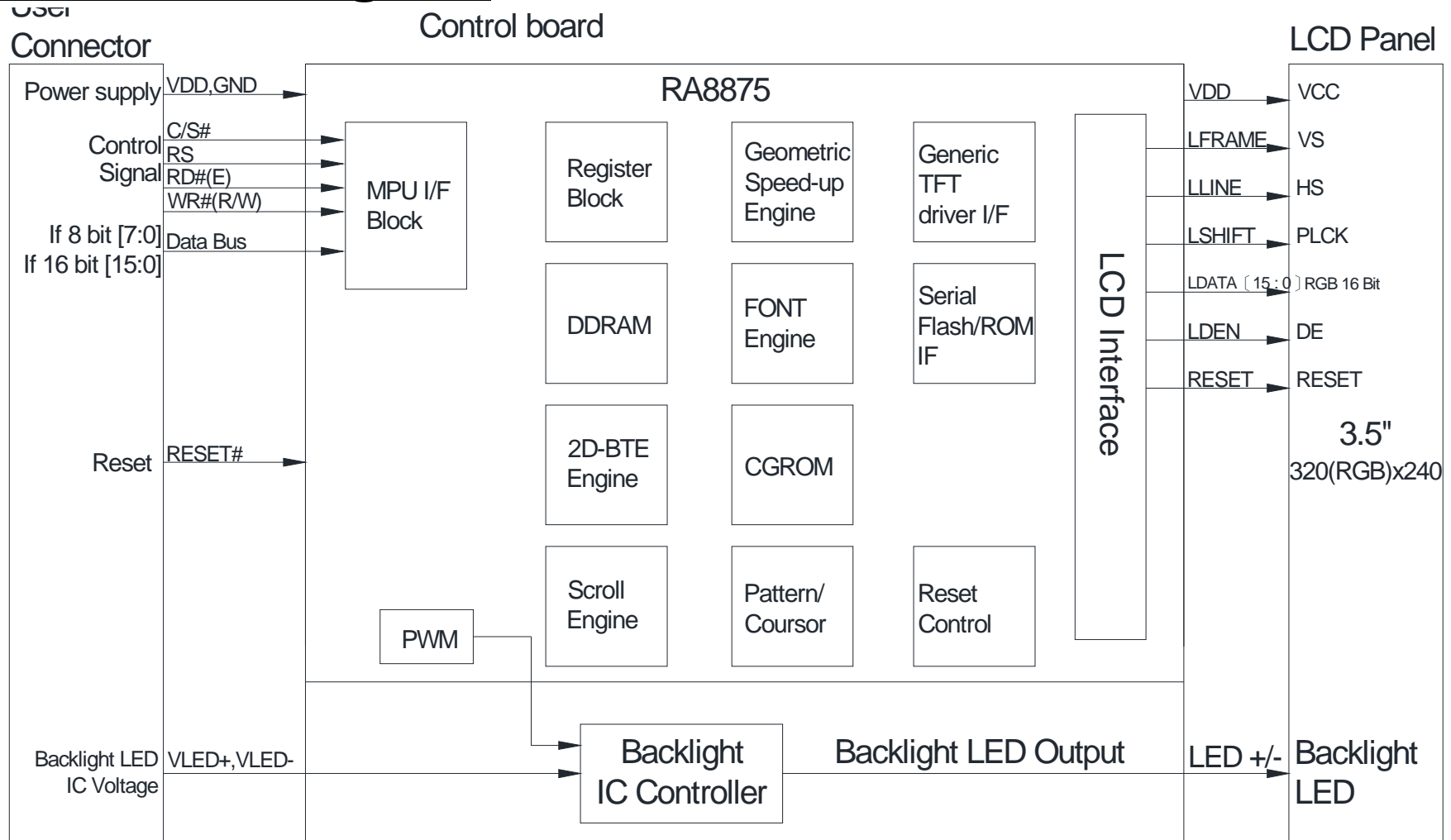

# 11. Reliability

Content of Reliability Test (Wide temperature, -20°C~70°C)

Environmental Test			
Test Item	Content of Test	Test Condition	Note
High Temperature storage	Endurance test applying the high storage temperature for a long time.	80°C 200hrs	2
Low Temperature storage	Endurance test applying the low storage temperature for a long time.	-30°C 200hrs	1,2
High Temperature Operation	Endurance test applying the electric stress (Voltage & Current) and the thermal stress to the element for a long time.	70°C 200hrs	—
Low Temperature Operation	Endurance test applying the electric stress under low temperature for a long time.	-20°C 200hrs	1
High Temperature/ Humidity Operation	The module should be allowed to stand at 60 °C,90%RH max For 96hrs under no-load condition excluding the polarizer, Then taking it out and drying it at normal temperature.	60°C,90%RH 96hrs	1,2
Thermal shock resistance	The sample should be allowed stand the following 10 cycles of operation  <div style="text-align: center;"> <p style="text-align: center;">-20°C    25°C    70°C</p> <p style="text-align: center;">30min ← 5min → 30min</p> <p style="text-align: center;">1 cycle</p> </div>	-20°C/70°C 10 cycles	—
Vibration test	Endurance test applying the vibration during transportation and using.	Total fixed amplitude : 15mm Vibration Frequency : 10~55Hz One cycle 60 seconds to 3 directions of X,Y,Z for Each 15 minutes	3
Static electricity test	Endurance test applying the electric stress to the terminal.	VS=800V, RS=1.5kΩ CS=100pF 1 time	—

Note1: No dew condensation to be observed.

Note2: The function test shall be conducted after 4 hours storage at the normal Temperature and humidity after remove from the test chamber.

Note3: The packing have to including into the vibration testing.



# 12. Contour Drawing

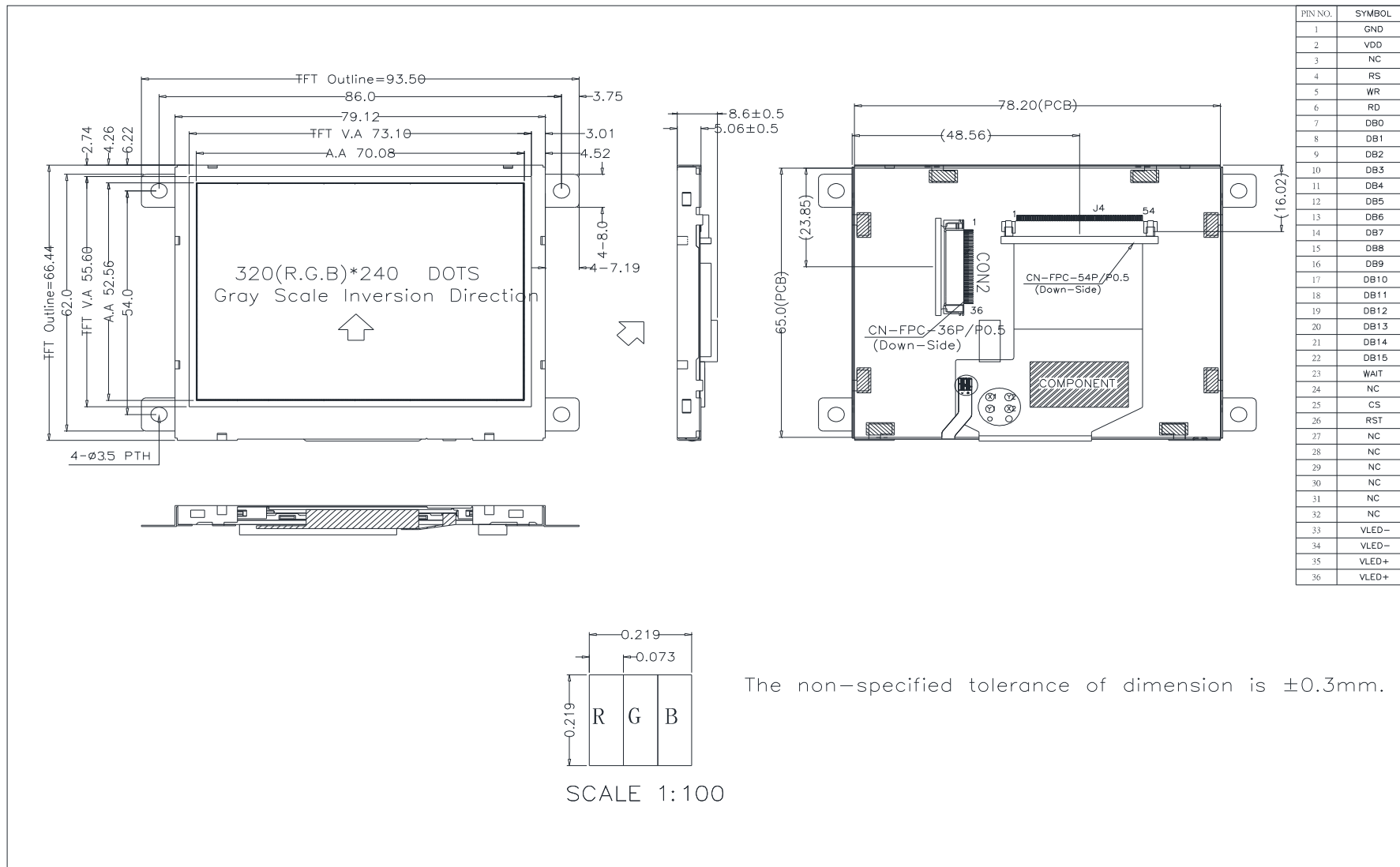

# 13.PACKAGE SPECIFICATION

<table border="1" style="width: 100%; border-collapse: collapse;"> <tr> <td style="width: 50%;">LCM Model</td> <td>WF35PTIBCDBN0#</td> </tr> <tr> <td>Drawing NO.</td> <td></td> </tr> </table>	LCM Model	WF35PTIBCDBN0#	Drawing NO.		<h2 style="margin: 0;">LCM 包裝規格書</h2> <h3 style="margin: 0;">LCM Packaging Specifications</h3>	<table border="1" style="width: 100%; border-collapse: collapse;"> <tr> <td style="width: 33%;">Approve</td> <td style="width: 33%;">Check</td> <td style="width: 33%;">Contact</td> </tr> <tr> <td>DATE</td> <td>初版</td> <td>版次 Ver</td> </tr> <tr> <td>02/05/14'</td> <td>02/05/14'</td> <td>0</td> </tr> </table>	Approve	Check	Contact	DATE	初版	版次 Ver	02/05/14'	02/05/14'	0
LCM Model	WF35PTIBCDBN0#														
Drawing NO.															
Approve	Check	Contact													
DATE	初版	版次 Ver													
02/05/14'	02/05/14'	0													
<b>1.包裝材料規格表 (Packaging Material) :(per carton)</b>															
NO.	Item	Model	Dimensions	Quantity											
1	成品 (LCM)	WF35PTIBCDBN0#		216											
2	TRAY 盤 (2)	PKCA1XXXXXXXXXXXX0355	315*265mm	36											
3	BP01 內盒(3)Product Box	PK3Y1XXXXXXXXXXXX0001	332*280*100mm	6											
4	泡棉(4)Foam	-----	-	6											
5	外紙箱(5)Carton	PK4X1XXXXXXXXXXXX0000	565*340*320mm	1											
6															
7															
8															
9															
<b>2.單箱數量規格表(Packaging Specifications and Quantity) :</b> (1)LCM quantity per box : no per tray                      6    x no of tray                      6 = 36 (2)Total LCM quantity in carton : quantity per box    36    x no of boxes                      6 = 216															
<b>特 記 事 項 (REMARK)</b>															
<b>1. Label Specifications :</b> <table border="1" style="width: 100%; border-collapse: collapse; margin-top: 5px;"> <tr><td style="padding: 2px;">MOOEL:</td></tr> <tr><td style="padding: 2px;">LOT NO :</td></tr> <tr><td style="padding: 2px;">QUANTITY:</td></tr> <tr><td style="padding: 2px;">CHECK:</td></tr> </table>	MOOEL:	LOT NO :	QUANTITY:	CHECK:											
MOOEL:															
LOT NO :															
QUANTITY:															
CHECK:															

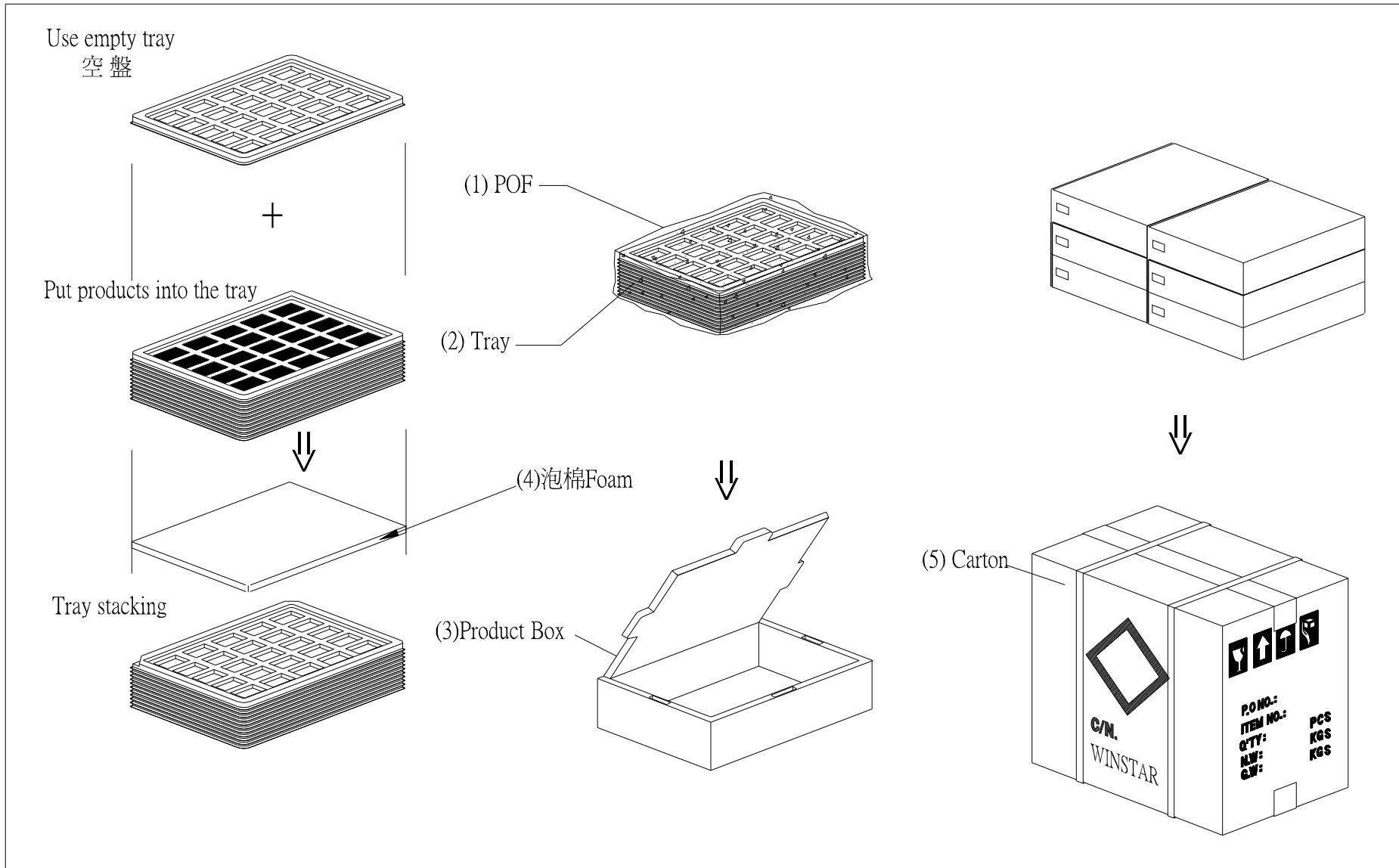

# 14.Initial Code For Reference

```
void Initial_RA8875()
{
    RES = 1;
    Delay1ms (10);
    RES = 0;
    Delay1ms (50);
    RES = 1;
    Delay1ms (100);

    LCD_CmdWrite(0x88);
    LCD_DataWrite(0x0a);
    Delay1ms(1);
    LCD_CmdWrite(0x89);
    LCD_DataWrite(0x02);
    Delay1ms(1);

    LCD_CmdWrite(0x10);
    LCD_DataWrite(0x0c);

    LCD_CmdWrite(0x04);
    LCD_DataWrite(0x03);
    Delay1ms(1);

    //Horizontal set
    LCD_CmdWrite(0x14);
    LCD_DataWrite(0x27);
    LCD_CmdWrite(0x15);
    LCD_DataWrite(0x80);
    LCD_CmdWrite(0x16);
    LCD_DataWrite(0x03);
    LCD_CmdWrite(0x17);
    LCD_DataWrite(0x02);
    LCD_CmdWrite(0x18);
    LCD_DataWrite(0x03);

    LCD_CmdWrite(0x19);
    LCD_DataWrite(0xef);
    LCD_CmdWrite(0x1A);
    LCD_DataWrite(0x00);
    LCD_CmdWrite(0x1B);
    LCD_DataWrite(0x0f);
    LCD_CmdWrite(0x1C);
    LCD_DataWrite(0x00);
    LCD_CmdWrite(0x1D);
    LCD_DataWrite(0x0e);
    LCD_CmdWrite(0x1E);
    LCD_DataWrite(0x06);
    LCD_CmdWrite(0x1F);
```

```
LCD_DataWrite(0x01);
```

```
LCD_CmdWrite(0x30);  
LCD_DataWrite(0x00);  
LCD_CmdWrite(0x31);  
LCD_DataWrite(0x00);  
LCD_CmdWrite(0x34);  
LCD_DataWrite(0x3F);  
LCD_CmdWrite(0x35);  
LCD_DataWrite(0x01);
```

```
LCD_CmdWrite(0x32);  
LCD_DataWrite(0x00);  
LCD_CmdWrite(0x33);  
LCD_DataWrite(0x00);  
LCD_CmdWrite(0x36);  
LCD_DataWrite(0xef);  
LCD_CmdWrite(0x37);  
LCD_DataWrite(0x00);
```

```
}
```



winstar **LCM Sample Estimate Feedback Sheet**

Module Number : \_\_\_\_\_

Page: 1

**1、Panel Specification :**

- 1. Panel Type :  Pass  NG , \_\_\_\_\_
- 2. View Direction :  Pass  NG , \_\_\_\_\_
- 3. Numbers of Dots :  Pass  NG , \_\_\_\_\_
- 4. View Area :  Pass  NG , \_\_\_\_\_
- 5. Active Area :  Pass  NG , \_\_\_\_\_
- 6. Operating Temperature :  Pass  NG , \_\_\_\_\_
- 7. Storage Temperature :  Pass  NG , \_\_\_\_\_
- 8. Others : \_\_\_\_\_

**2、Mechanical Specification :**

- 1. PCB Size :  Pass  NG , \_\_\_\_\_
- 2. Frame Size :  Pass  NG , \_\_\_\_\_
- 3. Material of Frame :  Pass  NG , \_\_\_\_\_
- 4. Connector Position :  Pass  NG , \_\_\_\_\_
- 5. Fix Hole Position :  Pass  NG , \_\_\_\_\_
- 6. Backlight Position :  Pass  NG , \_\_\_\_\_
- 7. Thickness of PCB :  Pass  NG , \_\_\_\_\_
- 8. Height of Frame to PCB :  Pass  NG , \_\_\_\_\_
- 9. Height of Module :  Pass  NG , \_\_\_\_\_
- 10. Others :  Pass  NG , \_\_\_\_\_

**3、Relative Hole Size :**

- 1. Pitch of Connector :  Pass  NG , \_\_\_\_\_
- 2. Hole size of Connector :  Pass  NG , \_\_\_\_\_
- 3. Mounting Hole size :  Pass  NG , \_\_\_\_\_
- 4. Mounting Hole Type :  Pass  NG , \_\_\_\_\_
- 5. Others :  Pass  NG , \_\_\_\_\_

**4、Backlight Specification :**

- 1. B/L Type :  Pass  NG , \_\_\_\_\_
- 2. B/L Color :  Pass  NG , \_\_\_\_\_
- 3. B/L Driving Voltage (Reference for LED Type) :  Pass  NG , \_\_\_\_\_
- 4. B/L Driving Current :  Pass  NG , \_\_\_\_\_
- 5. Brightness of B/L :  Pass  NG , \_\_\_\_\_
- 6. B/L Solder Method :  Pass  NG , \_\_\_\_\_
- 7. Others :  Pass  NG , \_\_\_\_\_

>> **Go to page 2** <<



**Winstar**

**Module Number :** \_\_\_\_\_

**Page: 2**

**5、Electronic Characteristics of Module :**

- |                              |                               |                                     |
|------------------------------|-------------------------------|-------------------------------------|
| 1. Input Voltage :           | <input type="checkbox"/> Pass | <input type="checkbox"/> NG , _____ |
| 2. Supply Current :          | <input type="checkbox"/> Pass | <input type="checkbox"/> NG , _____ |
| 3. Driving Voltage for LCD : | <input type="checkbox"/> Pass | <input type="checkbox"/> NG , _____ |
| 4. Contrast for LCD :        | <input type="checkbox"/> Pass | <input type="checkbox"/> NG , _____ |
| 5. B/L Driving Method :      | <input type="checkbox"/> Pass | <input type="checkbox"/> NG , _____ |
| 6. Negative Voltage Output : | <input type="checkbox"/> Pass | <input type="checkbox"/> NG , _____ |
| 7. Interface Function :      | <input type="checkbox"/> Pass | <input type="checkbox"/> NG , _____ |
| 8. LCD Uniformity :          | <input type="checkbox"/> Pass | <input type="checkbox"/> NG , _____ |
| 9. ESD test :                | <input type="checkbox"/> Pass | <input type="checkbox"/> NG , _____ |
| 10. Others :                 | <input type="checkbox"/> Pass | <input type="checkbox"/> NG , _____ |

**6、Summary :**

**Sales signature :** \_\_\_\_\_

**Customer Signature :** \_\_\_\_\_

**Date :**     /     /     \_\_\_\_\_