



Winstar Display Co., LTD

華凌光電股份有限公司

WEB: <http://www.winstar.com.tw>

E-mail: winstar@winstar.com.tw



SPECIFICATION

CUSTOMER : _____

MODULE NO.: WF35MTIBCDRNO#

<p>APPROVED BY:</p> <p>(FOR CUSTOMER USE ONLY)</p>	<p>PCB VERSION: _____</p> <p>DATA: _____</p>
---	--

SALES BY	APPROVED BY	CHECKED BY	PREPARED BY
			葉虹蘭
ISSUED DATE: 2014/01/28			

TFT Display Inspection Specification: <http://www.winstar.com.tw/service.php>

Distributed by:



www.texim-europe.com



RECORDS OF REVISION

DOC. FIRST ISSUE

VERSION	DATE	REVISED PAGE NO.	SUMMARY
0	2014/01/28		First issue

Contents

1.Module Classification Information

2.Summary

3.General Specification

4.Absolute Maximum Ratings

5.Electrical Characteristics

6.DC Characteristics

7.Instructions Table

8.Optical Characteristics

9.Interface

10.Block Diagram

11.Reliability

12.Contour Drawing

13.Other

1.Module Classification Information

W	F	35	M	T	I	B	C	D	R	N	0	#
①	②	③	④	⑤	⑥	⑦	⑧	⑨	⑩	⑪	⑫	⑬

①	Brand : WINSTAR DISPLAY CORPORATION	
②	Display Type : F→TFT Type, J→Custom TFT	
③	Display Size : 3.5" TFT	
④	Model serials no.	
⑤	Backlight Type :	T→LED, White
⑥	LCD Polarize Type/ Temperature range/ Gray Scale Inversion Direction	I→Transmissive, W. T, 6:00 L→Transmissive, W.T,12:00
⑦	B : TFT+FR+CONTROL BOARD	
⑧	Solution: C : 320 * 240	
⑨	TFT type D: Digital panel	
⑩	Interface : R:RS232 S: SPI-4 (preservation)	
⑪	TS : N : Without TS T : RTP (preservation)	
⑫	Version	
⑬	Special Code	#:Fit in with ROHS directive regulations



2.SUMMARY

This technical specification applies to 3.5”color TFT-LCD panel. The 3.5”color TFT-LCD panel is designed for camcorder, digital camera application and other electronic products which require high quality flat panel displays. This module follows RoHS.

3. General Specifications

Item	Dimension	Unit
Dot Matrix	320 x RGBx240(TFT)	dots
Module dimension	100(W) x 66.44(H) x 5.76 (D)(MAX)	mm
Active area	70.08 x 52.56	mm
Dot pitch	0.219 x 0.073	mm
LCD type	TFT, Normally White, Transmissive	
View Direction	12 o'clock	
Gray Scale Inversion Direction	6 o'clock	
Backlight Type	LED, Normally White	
Interface	RS232 19200 Baud rate	

*Color tone slight changed by temperature and driving voltage

4. Absolute Maximum Ratings

Item	Symbol	Min	Typ	Max	Unit
Operating Temperature	TOP	-20	—	+70	°C
Storage Temperature	TST	-30	—	+80	°C

Note: Device is subject to be damaged permanently if stresses beyond those absolute maximum ratings listed above

- Temp. $\leq 60^{\circ}\text{C}$, 90% RH MAX. Temp. $> 60^{\circ}\text{C}$, Absolute humidity shall be less than 90% RH at 60°C

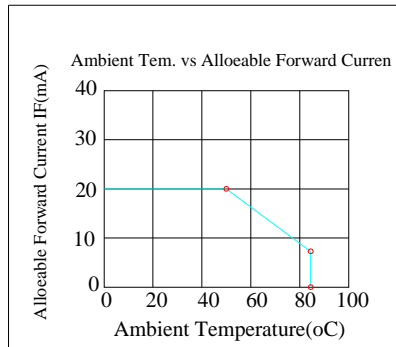

5. Electrical Characteristics

5.1. Operating conditions:

Item	Symbol	Condition	Min	Typ	Max	Unit	Remark
Supply Voltage For LCM	VDD	—	4.5	5	5.5	V	—
Supply Current For LCM	IDD	—	—	160	240	mA	Note1
Power Consumption	—	VDD=5V	—	800	1320	mW	VDD=5V Note 2

Note 1 : This value is test for VDD=5V , Ta=25 °C only

Note 2 : Power consumption is include Backlight driver system

5.2. LED driving conditions (LED Driver system build in)

Parameter	Symbol	Min.	Typ.	Max.	Unit	Remark
LED current		-	20	-	mA	
Power Consumption		348		408	mW	
LED voltage	VBL+	17.4	-	20.4	V	Note 1
LED Life Time		-	50,000	-	Hr	Note 2,3,4

Note 1 : There are 1 Groups LED

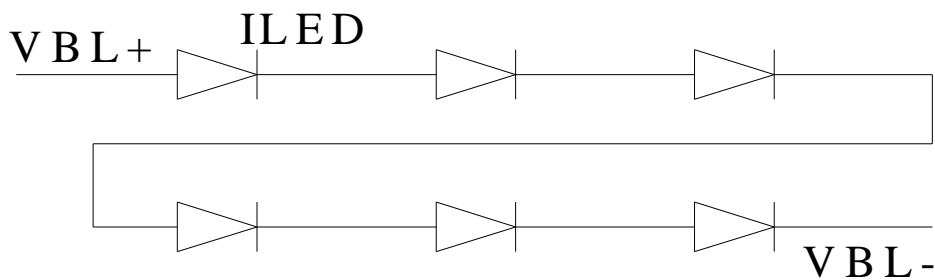

Note 2 : Ta = 25 °C

Note 3 : Brightness to be decreased to 50% of the initial value

Note 4 : The single LED lamp case

6.DC CHARATERISTICS

Parameter	Symbol	Rating			Unit	Condition
		Min	Typ	Max		
Low level input voltage	V_{IL}	0	-	0.3VDD	V	
High level input voltage	V_{IH}	0.7VDD	-	VDD	V	

7. Instructions Table

7.1. Text Mode

Instruction of text mode

1	2	3	4	5	6	7	8	9	10	11	12	13	14	15	16	17	18	19	20	21
SB 1	PL	SB 2	SB 3	M D	W R	TR	X H	XL	Y H	YL	S R	S G	SB	B R	B G	B B	TA SDA	EB 1	EB 2	EB 3

7.2. Graphic Mode

Instruction of Graphic mode:

1	2	3	4	5	6	7	8	9	10	11	12	13	14	15	16
SB1	PL	SB2	SB3	MD	RR	XH	XL	YH	YL	PH	PL	EB1	EB2	EB3	SB1

7.3. Pixel Mode

Instruction of Pixel mode

1	2	3	4	5	6	7	8	9	10	11	12	13	14	15	16
SB1	PL	SB2	SB3	MD	RR	XH	XL	YH	YL	PR	PG	PB	EB1	EB2	EB3

7.4. Geometry Mode

Instruction of geometry mode

1	2	3	4	5	6	7	8	9	10	11	12	13	14	15	16	17	18	19	20	21
SB 1	PL	SB 2	SB 3	M D	R R	XS H	XS L	YS H	YS L	XE H	XE L	YE H	YE L	LS	LR	LG	LB	EB 1	EB 2	EB 3

7.5. Clean Mode

Instruction of Clean Mode

1	2	3	4	5	6	7	8	9	10	11	12	13	14	15	16
SB1	PL	SB 2	SB 3	MD	XSH	XSL	YSH	YSL	XEH	XEL	YEH	YEL	EB1	EB2	EB3

7.6. PWM Mode

Instruction of Pixel mode

1	2	3	4	5	6	7	8	9	10	11	12	13
SB1	PL	SB2	SB3	MD	PS	PFH	PFL	PDH	PDL	EB1	EB2	EB3

7.7. Backlight Mode

Instruction of Clean Mode

1	2	3	4	5	6	7	8	9	10	11	12	13	14	15	16
SB1	PL	SB2	SB3	MD	RR	XH	XL	YH	YL	PR	PG	PB	EB1	EB2	EB3

8. Optical Characteristics

Item	Symbol	Condition.	Min	Typ.	Max.	Unit	Remark	
Response time	Tr	$\theta = 0^\circ$ 、 $\Phi = 0^\circ$	-	10		.ms	Note 3,5	
	Tf		-	15		.ms		
Contrast ratio	CR	At optimized viewing angle	300	350	-	-	Note 4,5	
Color Chromaticity	White	$\theta = 0^\circ$ 、 $\Phi = 0^\circ$	Wx	0.26	0.31	0.36		Note 2,6,7
			Wy	0.28	0.33	0.38		
Viewing angle	Hor.	$CR \geq 10$	Θ_R	50	60		Deg.	Note 1
			Θ_L	50	60			
	Ver.		Φ_T	40	50			
			Φ_B	45	55			
Brightness	-	-	350	420	-	cd/m ²	Center of display	

Ta=25±2°C, IL=20mA

Note 1: Definition of viewing angle range

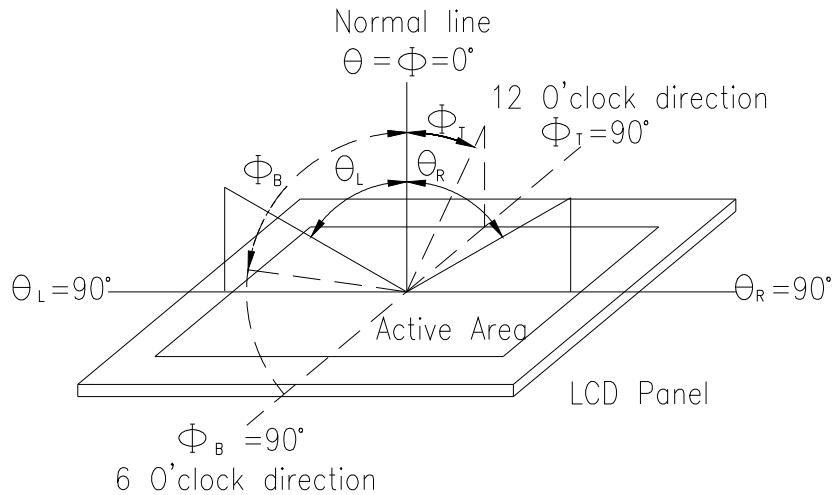

Fig. 8.1. Definition of viewing angle

Note 2: Test equipment setup:

After stabilizing and leaving the panel alone at a driven temperature for 10 minutes, the measurement should be executed. Measurement should be executed in a stable, windless, and dark room. Optical specifications are measured by Topcon BM-7 or BM-5 luminance meter 1.0° field of view at a distance of 50cm and normal direction.

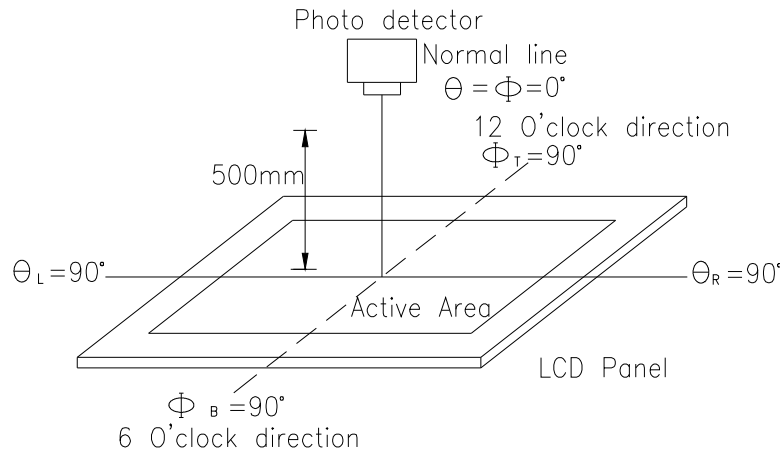
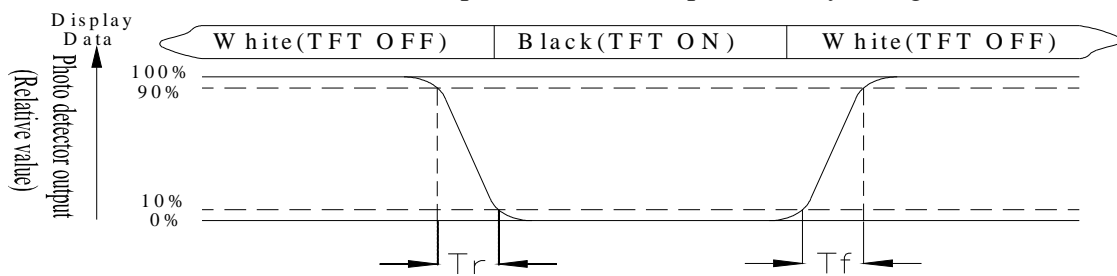

Fig. 8.2. Optical measurement system setup

Note 3: Definition of Response time:

The response time is defined as the LCD optical switching time interval between “White” state and “Black” state. Rise time, T_r , is the time between photo detector output intensity changed from 90% to 10%. And fall time, T_f , is the time between photo detector output intensity changed from 10% to 90%



Note 4: Definition of contrast ratio:

The contrast ratio is defined as the following expression.

$$\text{Contrast ratio (CR)} = \frac{\text{Luminance measured when LCD on the "White" state}}{\text{Luminance measured when LCD on the "Black" state}}$$

Note 5: White $V_i = V_{i50} \pm 1.5V$

Black $V_i = V_{i50} \pm 2.0V$

“±” means that the analog input signal swings in phase with VCOM signal.

“±” means that the analog input signal swings out of phase with VCOM signal.

The 100% transmission is defined as the transmission of LCD panel when all the input terminals of module are electrically opened.

Note 6: Definition of color chromaticity (CIE 1931)

Color coordinates measured at the center point of LCD

Note 7: Measured at the center area of the panel when all the input terminals of LCD panel are electrically opened.

$$\text{Note 8: Uniformity (U)} = \frac{\text{Brightness (min)}}{\text{Brightness (max)}} \times 100\%$$

9.Interface9.1.

CON 2			
Pin	Symbol	I/O	Function
1	GND	Power Supply	Power Ground
2	TX	O	RS232 Transmit pin
3	RX	I	RS232 Receive pin
4	VBUS	Power Supply	Power supply : 5V
5	D+	I/O	USB Data +
6	D-	I/O	USB Data -
7	GND	Power Supply	Power Ground
8	/REST	I	Reset (active Low)
9	GND	Power Supply	Power Ground
10	PWM	O	Pulse width modulation
11	GND	Power Supply	Power Ground
12	VBUS	Power Supply	Power supply : 5V

CON 3			
Pin	Symbol	I/O	Function
1	GND	Power Supply	Power Ground
2	SW1	I	Switch (active low)
3	SW2	I	Switch (active low)
4	SW3	I	Switch (active low)
5	SW4	I	Switch (active low)
6	GND	Power Supply	Power Ground
7	SDI	I	Serial Data Input
8	SDO	O	Serial Data Output
9	SCK	I	Serial Clock
10	SCS	I	Serial Chip selection
11	SPI_INT	O	Serial Interrupt
12	VBUS	Power Supply	Power supply : 5V

10.BLOCK DIAGRAM

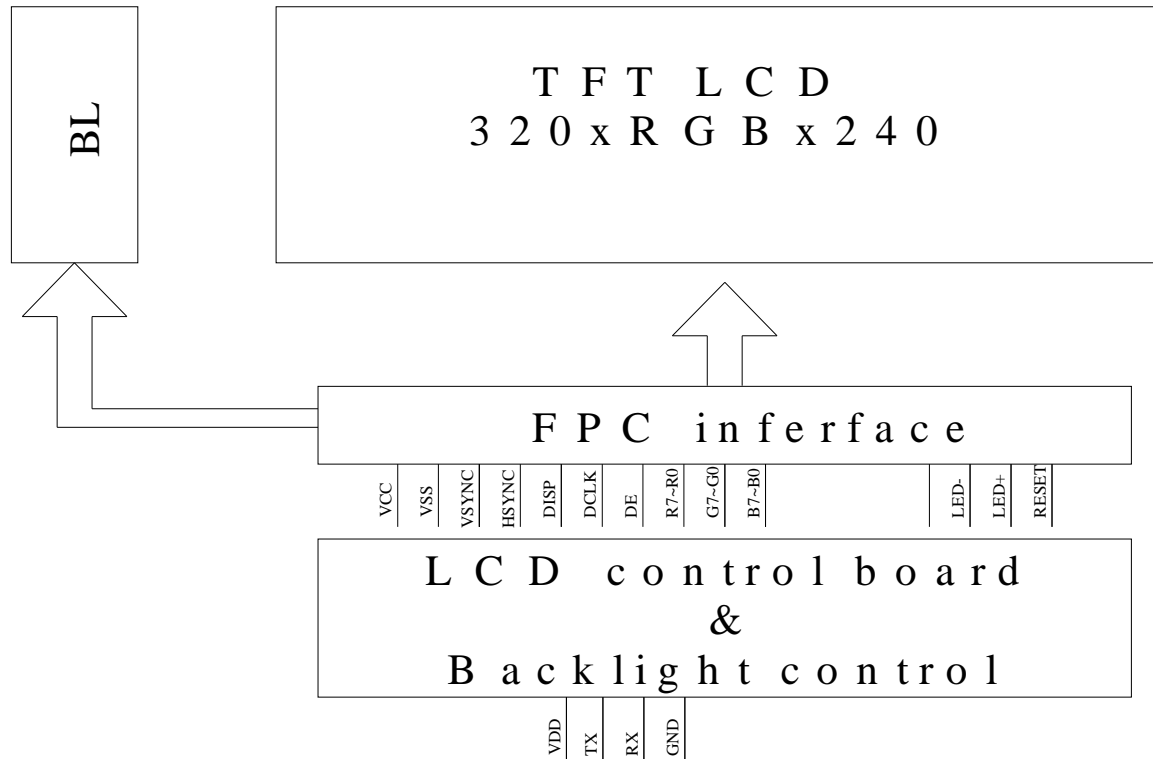

11. Reliability

Content of Reliability Test (Wide temperature, -20°C~70°C)

Environmental Test			
Test Item	Content of Test	Test Condition	Note
High Temperature storage	Endurance test applying the high storage temperature for a long time.	80°C 200hrs	2
Low Temperature storage	Endurance test applying the low storage temperature for a long time.	-30°C 200hrs	1,2
High Temperature Operation	Endurance test applying the electric stress (Voltage & Current) and the thermal stress to the element for a long time.	70°C 200hrs	—
Low Temperature Operation	Endurance test applying the electric stress under low temperature for a long time.	-20°C 200hrs	1
High Temperature/ Humidity Operation	The module should be allowed to stand at 60 °C,90%RH max For 96hrs under no-load condition excluding the polarizer, Then taking it out and drying it at normal temperature.	60°C,90%RH 96hrs	1,2
Thermal shock resistance	The sample should be allowed stand the following 10 cycles of operation <div style="text-align: center;"> <p style="text-align: center;">-20°C 25°C 70°C</p> <p style="text-align: center;"> </p> <p style="text-align: center;">30min 5min 30min</p> <p style="text-align: center;">1 cycle</p> </div>	-20°C/70°C 10 cycles	—
Vibration test	Endurance test applying the vibration during transportation and using.	Total fixed amplitude : 15mm Vibration Frequency : 10~55Hz One cycle 60 seconds to 3 directions of X,Y,Z for Each 15 minutes	3
Static electricity test	Endurance test applying the electric stress to the terminal.	C=150pF,R=330Ω,5point/panel Air:±8Kv,5times; Contact:±4Kv, 5times (Environment:15°C~35°C, 30%~60%.86Kpa~106Kpa)	—

Note1: No dew condensation to be observed.

Note2: The function test shall be conducted after 4 hours storage at the normal Temperature and humidity after remove from the test chamber.

Note3: The packing have to including into the vibration testing.

12. Contour Drawing

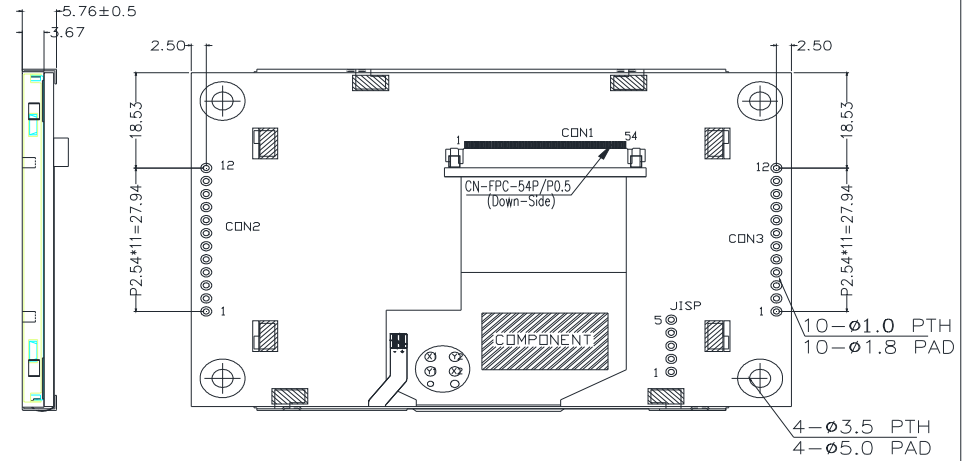
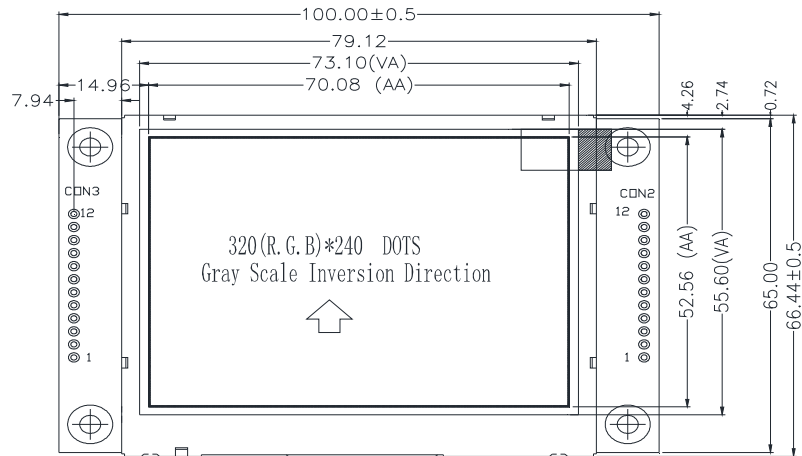

CON2		CON3	
PIN	SYMBOL	PIN	SYMBOL
1	GND	1	GND
2	TX	2	SW1
3	RX	3	SW2
4	VBUS	4	SW3
5	D+	5	SW4
6	D-	6	GND
7	GND	7	SDI
8	NC	8	SDO
9	GND	9	SCK
10	PWM	10	SCS
11	GND	11	SPI_INT
12	VBUS	12	VBUS

The non-specified tolerance of dimension is $\pm 0.3\text{mm}$.



1、Panel Specification :

- 1. Panel Type : Pass NG , _____
- 2. View Direction : Pass NG , _____
- 3. Numbers of Dots : Pass NG , _____
- 4. View Area : Pass NG , _____
- 5. Active Area : Pass NG , _____
- 6. Operating Temperature : Pass NG , _____
- 7. Storage Temperature : Pass NG , _____
- 8. Others : _____

2、Mechanical Specification :

- 1. PCB Size : Pass NG , _____
- 2. Frame Size : Pass NG , _____
- 3. Material of Frame : Pass NG , _____
- 4. Connector Position : Pass NG , _____
- 5. Fix Hole Position : Pass NG , _____
- 6. Backlight Position : Pass NG , _____
- 7. Thickness of PCB : Pass NG , _____
- 8. Height of Frame to PCB : Pass NG , _____
- 9. Height of Module : Pass NG , _____
- 10. Others : Pass NG , _____

3、Relative Hole Size :

- 1. Pitch of Connector : Pass NG , _____
- 2. Hole size of Connector : Pass NG , _____
- 3. Mounting Hole size : Pass NG , _____
- 4. Mounting Hole Type : Pass NG , _____
- 5. Others : Pass NG , _____

4、Backlight Specification :

- 1. B/L Type : Pass NG , _____
- 2. B/L Color : Pass NG , _____
- 3. B/L Driving Voltage (Reference for LED Type) : Pass NG , _____
- 4. B/L Driving Current : Pass NG , _____
- 5. Brightness of B/L : Pass NG , _____
- 6. B/L Solder Method : Pass NG , _____
- 7. Others : Pass NG , _____

>> **Go to page 2** <<



Winstar Module Number : _____

Page: 2

5、Electronic Characteristics of Module :

- | | | | |
|------------------------------|-------------------------------|-------------------------------|-------|
| 1. Input Voltage : | <input type="checkbox"/> Pass | <input type="checkbox"/> NG , | _____ |
| 2. Supply Current : | <input type="checkbox"/> Pass | <input type="checkbox"/> NG , | _____ |
| 3. Driving Voltage for LCD : | <input type="checkbox"/> Pass | <input type="checkbox"/> NG , | _____ |
| 4. Contrast for LCD : | <input type="checkbox"/> Pass | <input type="checkbox"/> NG , | _____ |
| 5. B/L Driving Method : | <input type="checkbox"/> Pass | <input type="checkbox"/> NG , | _____ |
| 6. Negative Voltage Output : | <input type="checkbox"/> Pass | <input type="checkbox"/> NG , | _____ |
| 7. Interface Function : | <input type="checkbox"/> Pass | <input type="checkbox"/> NG , | _____ |
| 8. LCD Uniformity : | <input type="checkbox"/> Pass | <input type="checkbox"/> NG , | _____ |
| 9. ESD test : | <input type="checkbox"/> Pass | <input type="checkbox"/> NG , | _____ |
| 10. Others : | <input type="checkbox"/> Pass | <input type="checkbox"/> NG , | _____ |

6、Summary :

Sales signature : _____

Customer Signature : _____

Date : / / _____