

CH03-BH060-A : SIM CARD HOLDER SMT 6 CONTACTS WITH SWITCH

FEATURES

- GENERAL CHARACTERISTICS**  
 DIMENSIONS: 29.70L x 17.20W x 2.50H mm  
 OPERATING POSITION: SHAFT UP / DOWN / HORIZONTAL  
 MOUNTING SYSTEM: SMT TYPE  
 DURABILITY: 5,000 CYCLES  
 OPERATION TEMPERATURE: -25°C TO +85°C
- MECHANICAL CHARACTERISTICS**  
 INSULATION MATERIAL: THERMOPLASTIC, UL 94V-0  
 CONTACT MATERIAL: PHOSPHOR BRONZE  
 CONTACT PLATING: GOLD ON CONTACT AREA, TIN ON SOLDER TAIL
- ELECTRICAL CHARACTERISTICS**  
 CONTACT RESISTANCE: 30M OHMS MAX.  
 INSULATION RESISTANCE: > 1000M OHMS MIN. / 500V DC  
 RATED CURRENT: 0.5A MAX.  
 RATED VOLTAGE: 30V AC  
 WITHSTANDING DIELECTRIC VOLTAGE: 500V AC R.M.S. FOR 1 MINUTE
- SOLDERABILITY**  
 MAX. PROCESSING TEMP.: 260°C FOR 10 SEC.

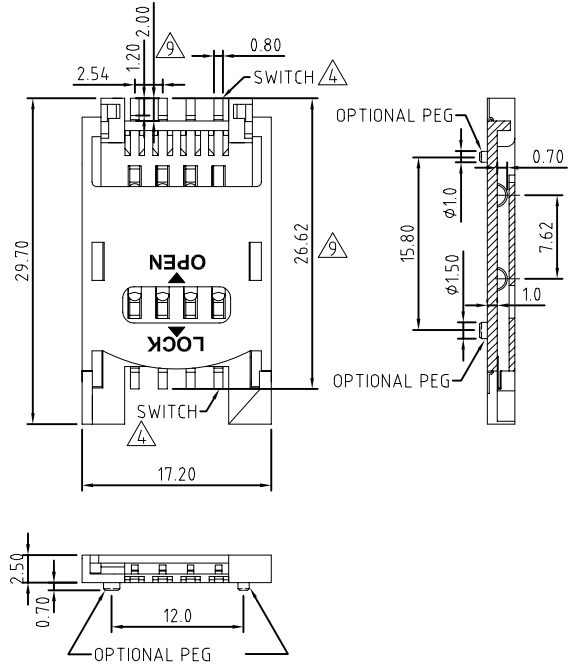
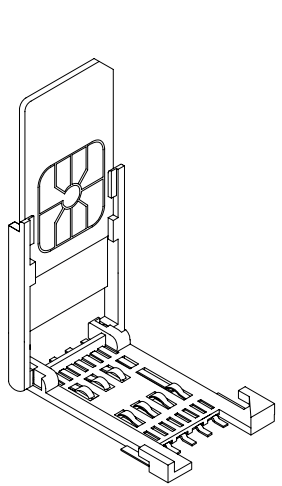

NOTES:  
 1. ACCEPTABLE SIM CARD SIZE SHOULD MEET GSM 11.11 SPECIFICATION REQUIREMENT  $\triangle$

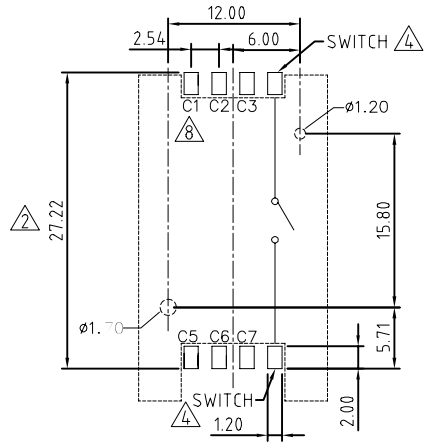

RECOMMENDED PCB LAYOUT

HOW TO ORDER

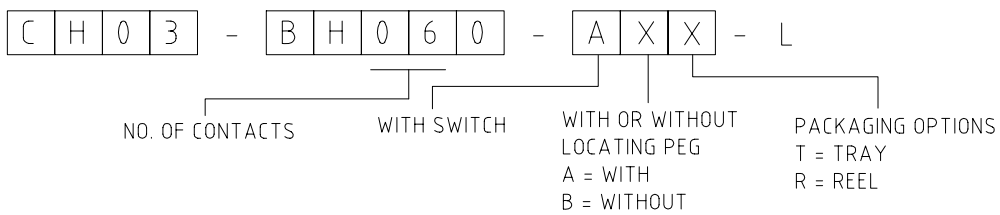

Distributed by:

www.texim-europe.com

REV.	DATE	DRN
10	07/07/03	- NYW RELEASE
11	12/11/04	- NYW
12	04/02/04	- NYW
13	21/03/06	- NYW
14	30/06/05	- NYW
15	14/07/06	- NYW
16	29/05/07	- NYW
17	04/06/08	- NYW
18	30/06/08	- CHC
19	18/03/09	- CHC
20	28/04/09	- CHC

1	REMOVE NON-ROHS VERSION
2	ADD NOTES 1
3	ADD ELECTRICAL SPEC.
4	DESIGNATE PIN 1
5	ADD DIMENSIONS
6	PACKAGING DRAWING ADDED

Scale:	2:1	THIRD ANGLE	Unstated Tolerances: 0 Dec Places 1 Dec Places 2 Dec Places 3 Dec Places	Material	SEE NOTE
Drawn:	CHC				
App'd:	XXXX	Title	SIM CARD ACCEPTOR		NOT TO SCALE
Date:	18 MAR '09	Revision :	2.0	Unit:	mm

www.gradconn.com

THIS DRAWING IS CONFIDENTIAL AND MUST NOT BE COPIED OR DISCLOSED WITHOUT WRITTEN CONSENT

Type:	CH03-BH
	CH03-BH060-A
Drawing Number:	
Sheet 1	of 3
Drawing C	E and O E

CH03-BH0X0-XXR-L - REEL PACKAGING DRAWING

SPECIFICATIONS

Reel Size: 330x44.5mm

PE Bag Size: 0.08x700x630mm

Carton Size: 346x346x330mm

QTY: 650Pcs/Reel

RoHS Compliant

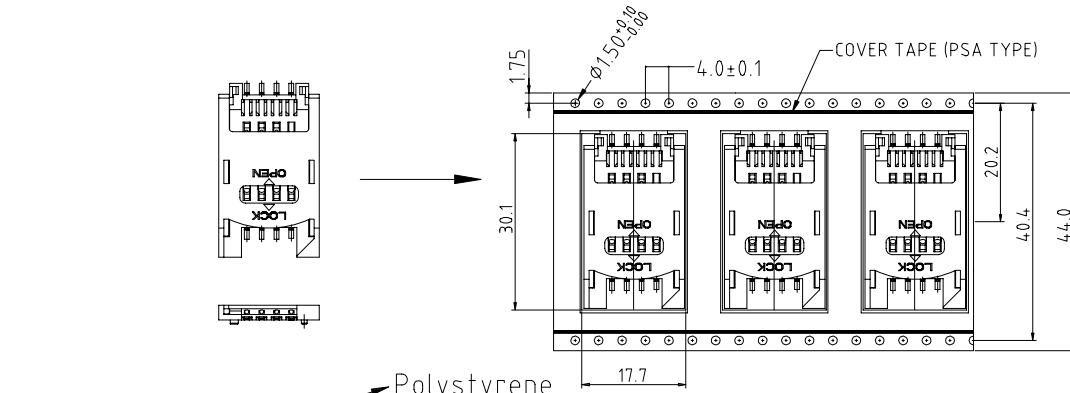

Packing Material Description  
Polystyrene

Polystyrene

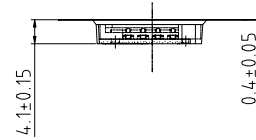
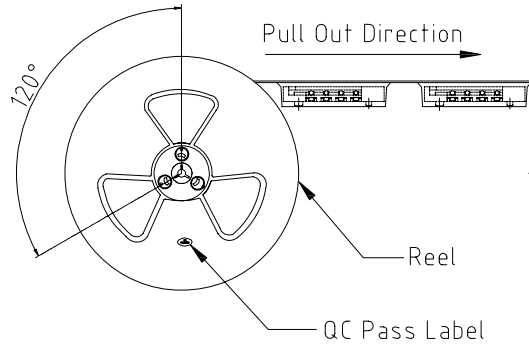

Plastic Reel for Embossed Tape

PE Bag

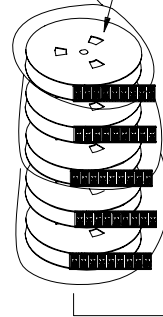

Card Board

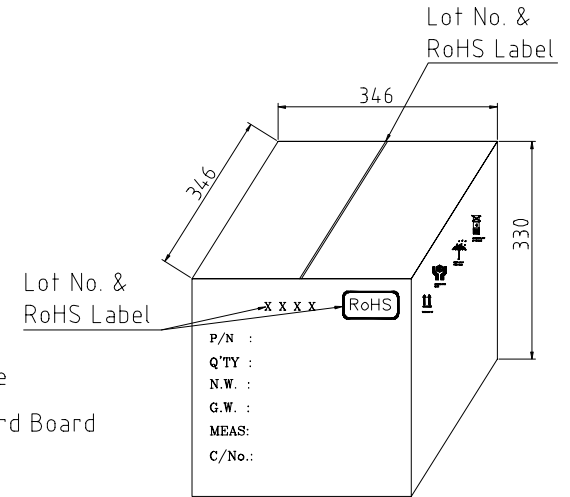
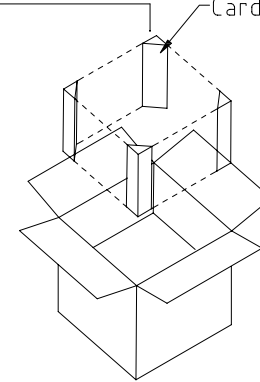

Note:

- 1). 1 REEL=650 PCS
- 2). 1 BOX=6 REEL

Distributed by:

www.texim-europe.com

REV. DATE & DRN 1.0 03/02/09 - CHC PACKAGING DRAWING ADDED	Drawn: CHC	THIRD ANGLE	Unstated Tolerances: .X ±0.20 .XX ±0.10	Material SEE NOTE
	App'd: XXX		ANGLES ±1°	NOT TO SCALE
	Date: 03 FEB '09	Title: PACKAGING		Unit: mm
		Revision: 1.0		

		Type: CH03-BH
www.gradconn.com		CH03-BH0X0-XXR-L
THIS DRAWING IS CONFIDENTIAL AND MUST NOT BE COPIED OR DISCLOSED WITHOUT WRITTEN CONSENT		Drawing Number:
©		Sheet 2 of 3
©		Drawing © E and O E

		Type: CH03-BH
www.gradconn.com		CH03-BH0X0-XXR-L
THIS DRAWING IS CONFIDENTIAL AND MUST NOT BE COPIED OR DISCLOSED WITHOUT WRITTEN CONSENT		Drawing Number:
©		Sheet 2 of 3
©		Drawing © E and O E

CH03-BH0X0-XXT-L - TRAY PACKAGING DRAWING

PACKING CONDITION

TRAY×10 (110PCS/TRAY)

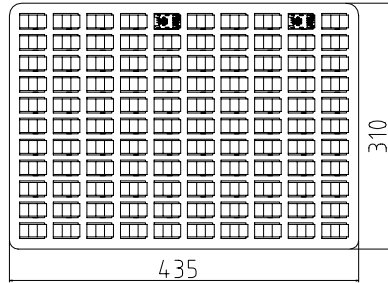

INNER BOX×5 (1100PCS/BOX)

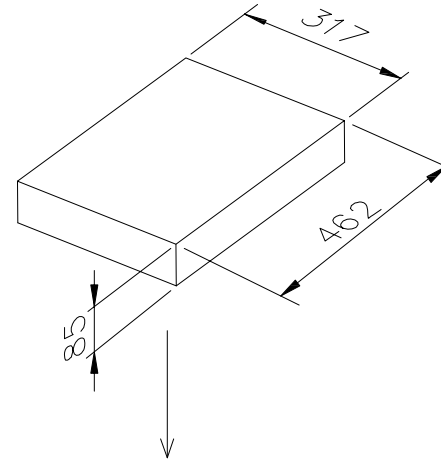

OUTER BOX×1 (5500PCS)

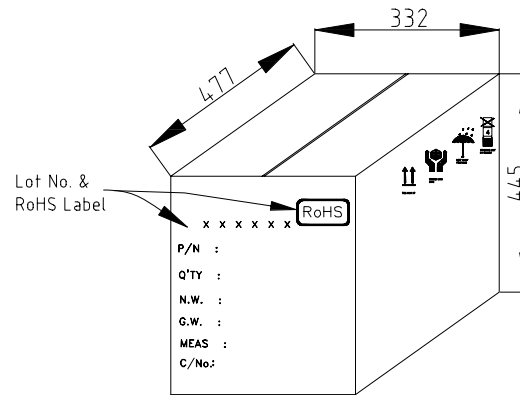

Q'TY/PCS		
OUTER BOX	INNER BOX	TRAY
5500	1100	110

Distributed by:

www.texim-europe.com

REV. DATE & DRN  
1.0 03/02/09 - CHC  
PACKAGING DRAWING ADDED

	THIRD ANGLE	Unstated .X .XX	Tolerances: ±0.20 ±0.10	Material SEE NOTE
Drawn: CHC		ANGLES ±1°		
App'd: XXX	Title: PACKAGING			NOT TO SCALE
Date: 03 FEB '09	Revision: 1.0			Unit: mm

www.gradconn.com

THIS DRAWING IS CONFIDENTIAL AND MUST NOT BE COPIED OR DISCLOSED WITHOUT WRITTEN CONSENT

Type: CH03-BH
CH03-BH0X0-XXT-L
Drawing Number:
Sheet 3 of 3
Drawing © E and O E

# TEXIM EUROPE

Partner in Electronic Components & Supply Chain Solutions



## The Netherlands

Elektrostraat 17  
NL-7483 PG Haaksbergen  
Tel: +31 (0)53 573 33 33  
Fax: +31 (0)53 573 33 30  
nl@texim-europe.com



## Belgium

Gentsesteenweg 1154-C22  
Chaussée de Gand 1154-C22  
B-1082 Brussel / Bruxelles  
Tel: +32 (0)2 462 01 00  
Fax: +32 (0)2 462 01 25  
belgium@texim-europe.com



## Denmark

Sdr. Jagtvej 12  
DK-2970 Hørsholm  
Tel: +45 88 20 26 30  
Fax: +45 88 20 26 39  
nordic@texim-europe.com



## Germany

Bahnhofstrasse 92  
D-25451 Quickborn  
Tel: +49 (0)4106 627 07-0  
Fax: +49 (0)4106 627 07-20  
germany@texim-europe.com



## Germany

Martin-Kollar-Strasse 9  
D-81829 München  
Tel: +49 (0)89 436 086-0  
Fax: +49 (0)89 436 086-19  
germany@texim-europe.com



## Austria

Warwitzstrasse 9  
A-5020 Salzburg  
Tel: +43 (0)662 216026  
Fax: +43 (0)662 216026-66  
austria@texim-europe.com



## United Kingdom

St. Mary's House, Church Lane  
Carlton Le Moorland  
Lincoln LN5 9HS  
Tel: +44 (0)1522 789 555  
Fax: +44 (0)845 299 22 26  
uk@texim-europe.com

For more information: [www.texim-europe.com](http://www.texim-europe.com)

