

A

B

C

D

Front View

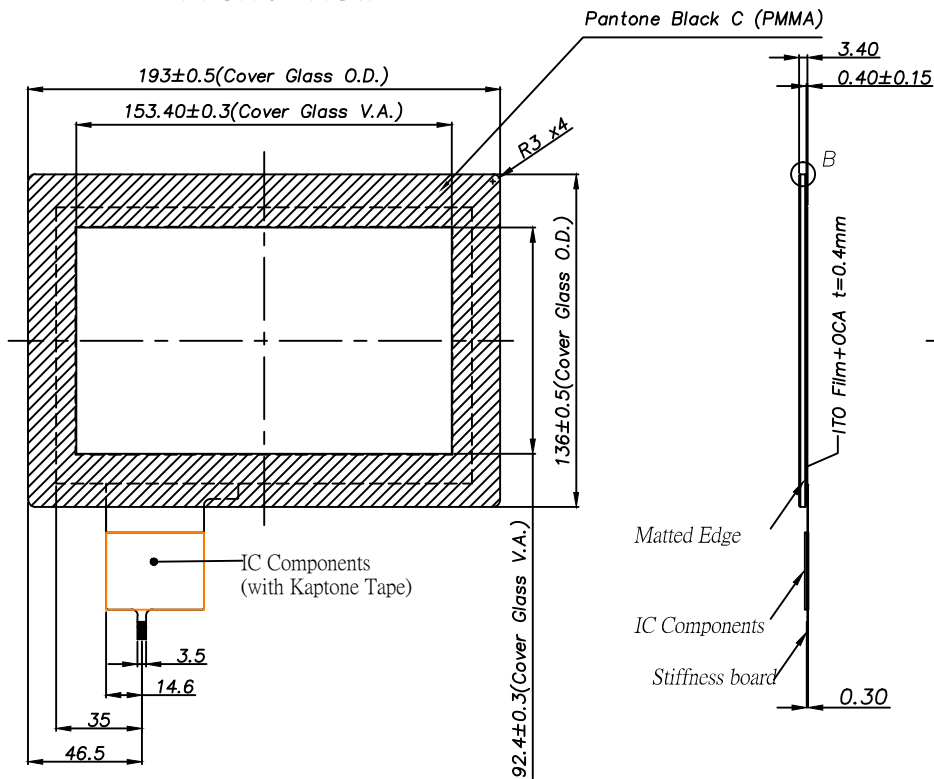

Back View

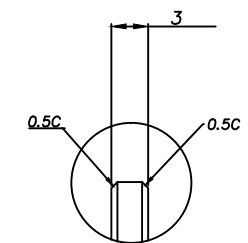
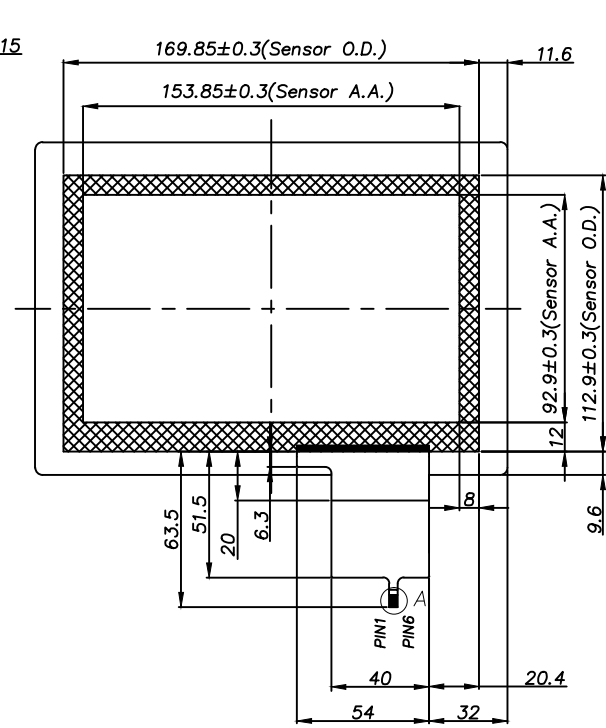

Detail B(5:1)

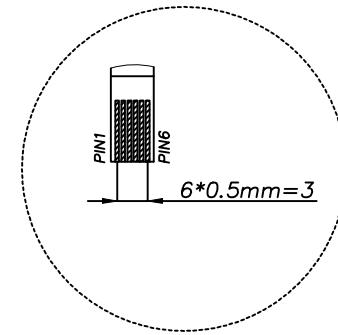

Detail A(5:1)

USB (OPTIONAL)	
Pin 01	VDD
Pin 02	D-
Pin 03	D+
Pin 04	GND
Pin 05	RST
Pin 06	NC

I2C (OPTIONAL)	
Pin 01	VDD
Pin 02	SDA
Pin 03	SCL
Pin 04	GND
Pin 05	RST
Pin 06	INT

Note:

- To choose the interface just add at the end of the part number the following : - U for USB - I for I2C
- Finger input only or special conductive pen
- Surface Hardness: depending by cover lens type
- Transmittance: >85% (JIS-K7105)
- Surface Treatment: Semi-Tempered Glass
- Distance between LCD and touch panel need to be minimum 1.0mm otherwise touch maybe will not work correctly
- If customer put a front cover all around need use at least 2mm thick gasket between touch and metal frame
- USB max ripple acceptable is 50mA, in other case touch will not work correctly
- Referring to the integration guide to avoid any integration noise issue

日期 原圖 智理

圖號 RTPC070W-A30BP1

03	20130805	Kevin Wang	Changed Glass Edge treatment to MATTED
02	20130718	Kevin Wang	Modified Glass O.D. tolerance to 0.5
01	20130617	Kevin Wang	Modified Pin Defined (USB&I2C)
版 年 月 日 設 計 審 查 變 更 承 認 內 容			
設 計 2012/04/01			

