

Touch Side View

| CONNECTOR PINOUT | |
|------------------|----------------|
| PIN# | DESIGNATION |
| 1 | Shielding |
| 2-16 | Blank |
| 17-48 | Y32-Y1 |
| 49 | Blank |
| 50-51 | Grounding Line |
| 52 | Blank |
| 53-107 | X1-X55 |
| 108-119 | Blank |
| 120 | Grounding Line |

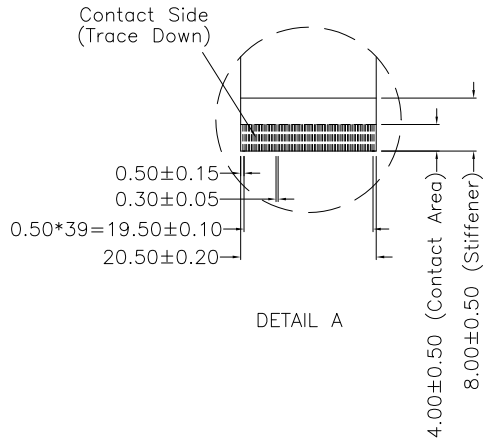

- NOTES:
1. INPUT MODE : PROJECTED CAPACITIVE
 2. OVERALL THICKNESS : 2.40±0.20mm
 3. COVER GLASS THICKNESS : 1.80mm
 4. FRONT SURFACE : CLEAR TYPE
 5. TAIL TYPE : GOLD PLATED FPC , ZIF
 6. RECOMMENDED CONTROL BOARDS : PENMOUNT PM1500 SERIES
 7. OTHER SPEC : SEE APPROVAL SHEET
 8. PLEASE REFER TO AMT TOUCH SCREEN INTEGRATION GUIDES FOR SYSTEM MECHANICAL DESIGN AND ASSEMBLY METHODS

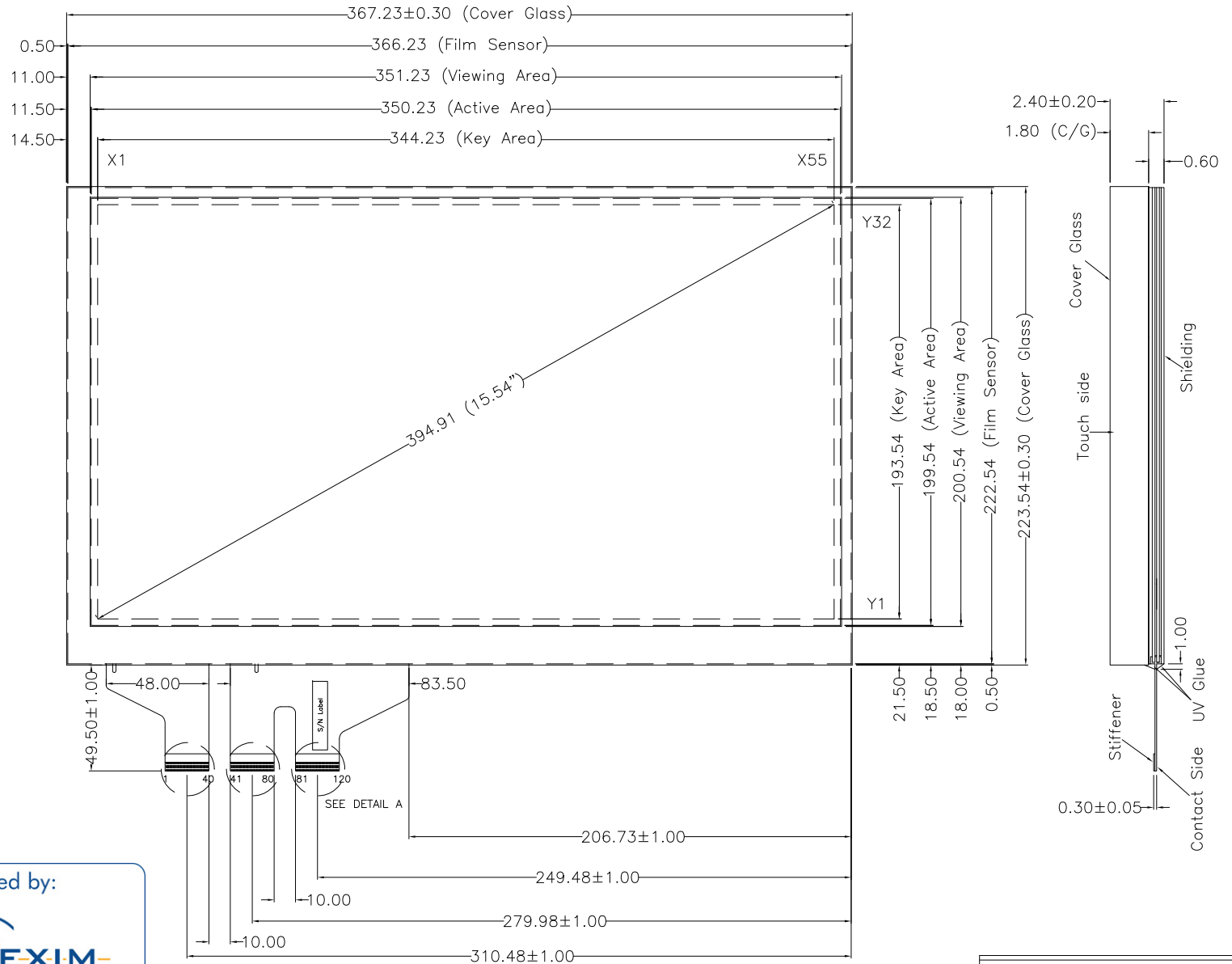

| NO. | DATE | DESCRIPTION | CHK |
|-----------------|-------|-----------------|---------------|
| REVISION | | | |
| CHIEF OF DESIGN | | APPROVED | Jerry |
| ENGINEER | | PROJECT MANAGER | |
| DRAWN BY | Andre | DATE | JUN 24 , 2013 |
| SHT | 1 | OF | 1 |
| | | REV. | 0 |

| TOLERANCES UNLESS SPECIFIED | | |
|-----------------------------|--------|-------------------------|
| .X | ± 0.50 | MODEL NAME : P3016-02 |
| .XX | ± 0.50 | DWG NO : P3016-02-0-011 |
| .XXX | ± 0.30 | SCALE: N/S UNIT: mm |
| ANGULAR | . | |

Apex Material Technology Corp.

TEXIM EUROPE

Partner in Electronic Components & Supply Chain Solutions



The Netherlands

Elektrostraat 17
NL-7483 PG Haaksbergen
Tel: +31 (0)53 573 33 33
Fax: +31 (0)53 573 33 30
nl@texim-europe.com



Belgium

Gentsesteenweg 1154-C22
Chaussée de Gand 1154-C22
B-1082 Brussel / Bruxelles
Tel: +32 (0)2 462 01 00
Fax: +32 (0)2 462 01 25
belgium@texim-europe.com



Denmark

Sdr. Jagtvej 12
DK-2970 Hørsholm
Tel: +45 88 20 26 30
Fax: +45 88 20 26 39
nordic@texim-europe.com



Germany

Bahnhofstrasse 92
D-25451 Quickborn
Tel: +49 (0)4106 627 07-0
Fax: +49 (0)4106 627 07-20
germany@texim-europe.com



Germany

Martin-Kollar-Strasse 9
D-81829 München
Tel: +49 (0)89 436 086-0
Fax: +49 (0)89 436 086-19
germany@texim-europe.com



Austria

Warwitzstrasse 9
A-5020 Salzburg
Tel: +43 (0)662 216026
Fax: +43 (0)662 216026-66
austria@texim-europe.com



United Kingdom

St. Mary's House, Church Lane
Carlton Le Moorland
Lincoln LN5 9HS
Tel: +44 (0)1522 789 555
Fax: +44 (0)845 299 22 26
uk@texim-europe.com

For more information: www.texim-europe.com

