

CUSTOMER' S APPROVAL SPECIFICATIONS



MODEL: CH090PDL-001

(Complied with RoHS)

ISSUE: DEC.11.2012

Spec Condition:preliminary

NO.	ITEM	PAGE
1	COVER	--
2	RECORD OF REVISION	0-1
3	MECHANICAL SPECIFICATIONS	1
4	OUTLINE DIMENSIONS	2
5	INTERFACE PIN CONNECTION	3
6	BLOCK DIAGRAM	4
7	ABSOLUTE MAXIMUM RATINGS	4
8	ELECTRICAL CHARACTERISTICS	5-6
9	OPTICAL CHARACTERISTICS	6-8
10	TIMING SPECIFICATIONS	9-10
11	RELIABILITY TEST	11
12	PRECAUTIONS FOR USE	12

CUSTOMER	ONATION		
APPROVAL	APPROVAL	CHECKER	PREPARE
	<i>ch lee</i>	<i>ch lee</i>	<i>cloud</i>

3.MECHANICAL SPECIFICATIONS

(1)	Number Of Dots (Dots)	800(R.G.B) X 480
(2)	Module Size(mm)	211.1(H) X 126.5(V) X 10(D) (**)
(3)	Active Area(mm)	198.0(H) X 111.7(V)
(4)	Pixel Pitch(mm)	0.2327 (H) X 0.2327(V)
(5)	LCD / Polarizer Model	TFT , Transmissive, Normally/White, Anti-Glare
(6)	Backlight Color	White, LED
(7)	Viewing Direction	12 O'clock
(8)	Gray Scale Inversion Direction	6 O'clock
(9)	Electrical Interface	LVDS Interface
(10)	Color Configuration	R.G.B Stripe
(11)	Module Weight(g)	280±5%

(**) Module include PCB and component.

4. OUTLINE DIMENSIONS

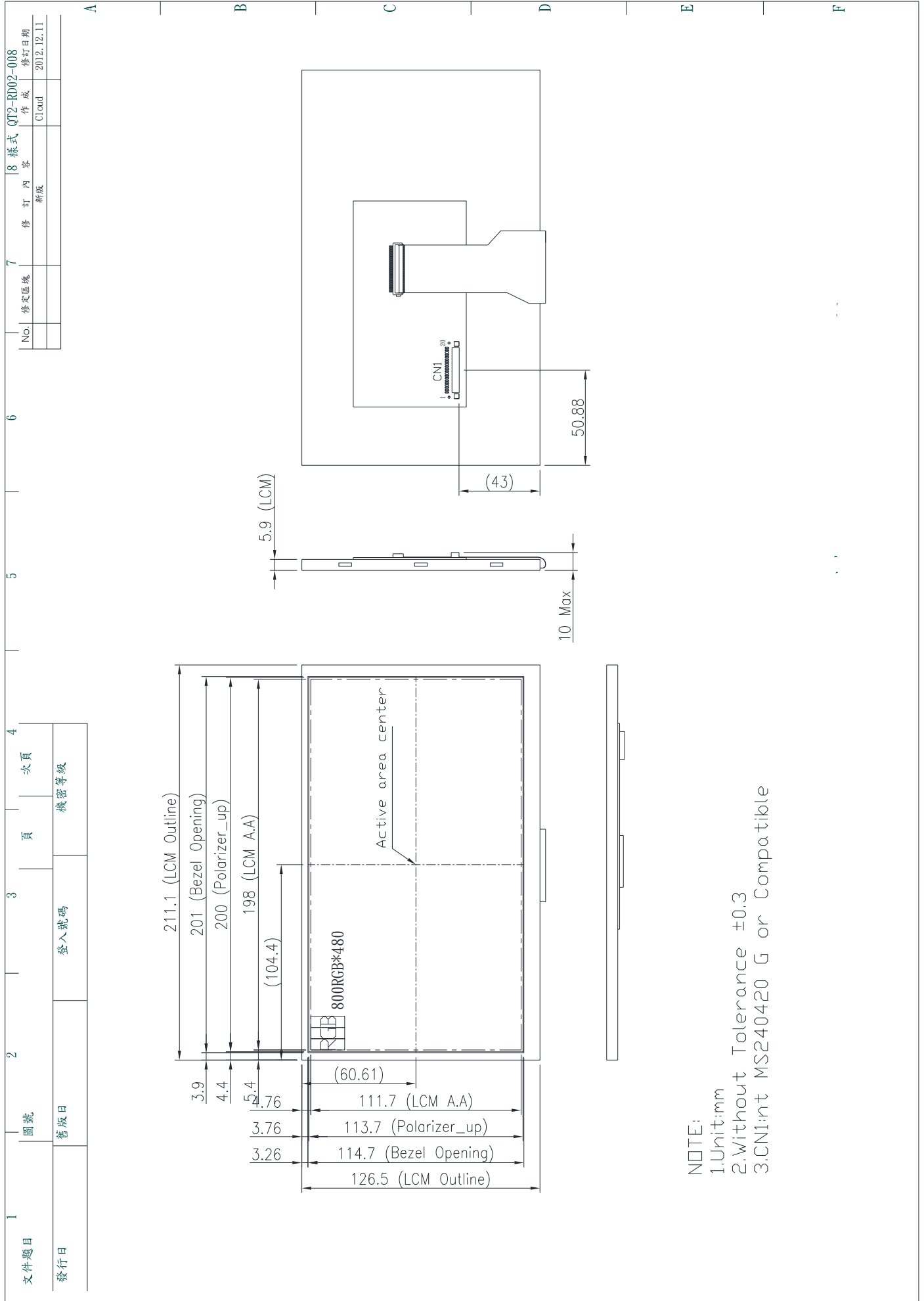

5. INTERFACE PIN CONNECTION

5.1 LCM PANEL DRIVING SECTION

CN1 Connector: MS240420 G or Compatible

PIN NO.	SIGNAL	FUNCTION
1	VCC	Power Supply For Digital Circuit
2	VCC	Power Supply For Digital Circuit
3	GND	Ground
4	GND	Ground
5	RxIN0-	Differential Data Input, CH0(Negative)
6	RxIN0+	Differential Data Input, CH0(Positive)
7	GND	Ground
8	RxIN1-	Differential Data Input, CH1(Negative)
9	RxIN1+	Differential Data Input, CH1(Positive)
10	GND	Ground
11	RxIN2-	Differential Data Input, CH2(Negative)
12	RxIN2+	Differential Data Input, CH2(Positive)
13	GND	Ground
14	CKIN-	Differential Clock Input(Negative)
15	CKIN+	Differential Clock Input(Positive)
16	GND	Ground
17	VLED	Power Supply For LED Driver Circuit
18	VLED	Power Supply For LED Driver Circuit
19	GND	Ground
20	ADJ	Brightness Control For LED B/L

6. BLOCK DIAGRAM

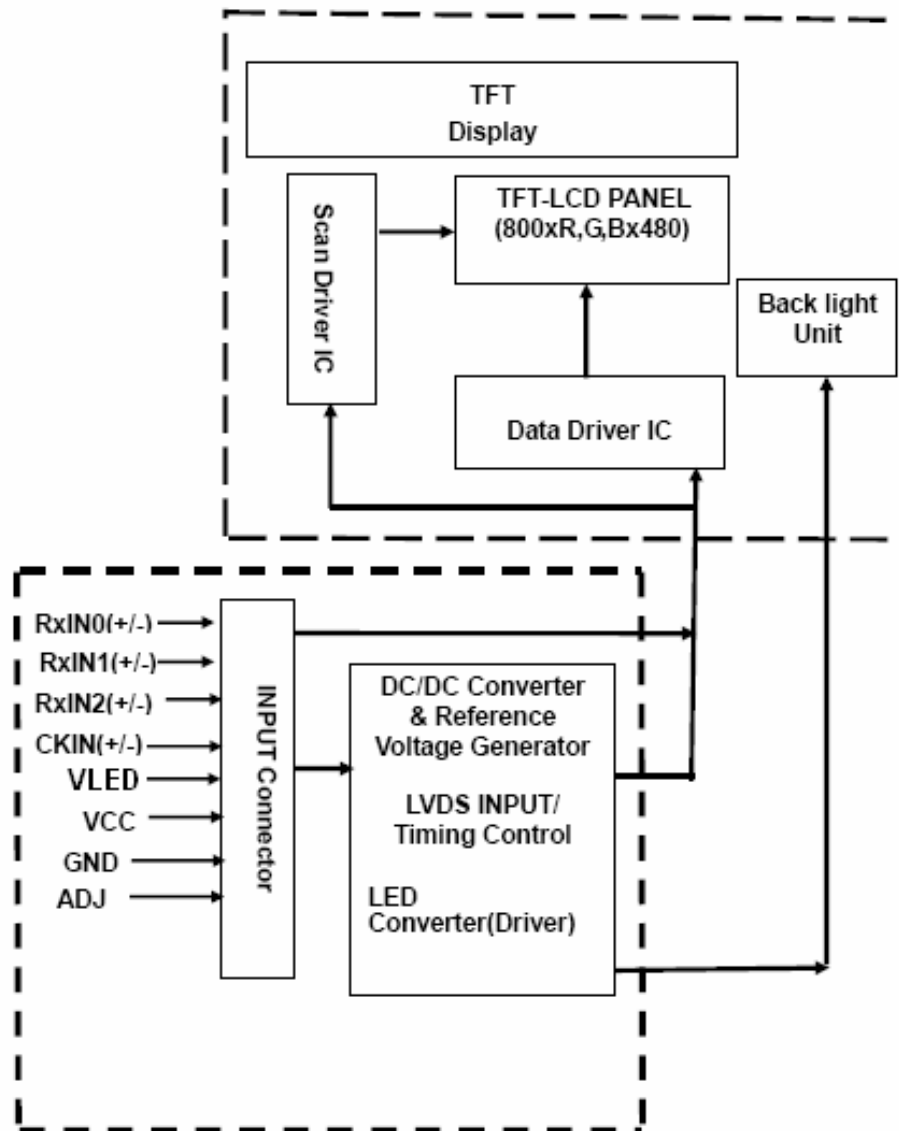

7. ABSOLUTE MAXIMUM RATINGS

7.1 ELECTRICAL ABSOLUTE MAXIMUM RATINGS

ITEM	SYMBOL	MIN.	MAX.	UNIT	REMARK
Supply Voltage	VCC	-0.3	+5.0	V	
	VLED	-4.5	+36	V	

7.2 ENVIRONMENTAL ABSOLUTE MAXIMUM RATINGS

ITEM	OPERATING		STORAGE		REMARK
	MIN.	MAX.	MIN.	MAX.	
Ambient Temperature(°C)	-20	80	-30	80	Note 1,2,3
Humidity(% RH)	-	90	-	90	Note 4

Note 1 : The response time will become lower when operated at low temperature.

Note 2 : Background color changes slightly depending on ambient temperature.

Note 3 : Operation Ta=80°C & -20°C ≤ 240Hrs.

Note 4 : Operation Ta=60°C & RH=90% ≤ 240Hrs.

8.ELECTRICAL CHARACTERISTICS

8.1 ELECTRICAL CHARACTERISTICS OF LCD

Ta=25°C

ITEM	SYMBOL	MIN.	TYP.	MAX.	UNIT
Power Voltage For LCD	VCC	3.0	3.3	3.6	V
	ICC	-	200	250	mA

Note 1 : Test condition : VCC=3.3V ; Test Pattern : Black

8.2 BACKLIGHT UNITS

Ta=25°C

ITEM	SYMBOL	MIN.	TYP.	MAX.	UNIT
LED Driving Voltage	VLED	4.5	5	15	V
	ILED	-	(1000)	(1200)	mA
ADJ Input Analog Dimming Voltage	-	0.7	-	1.4	V _{DC}
ADJ Input PWM Dimming Voltage	-	1.4	-	5.0	V _{p-p}
ADJ frequency	-	100	-	1000	Hz
LED Life Time (For Reference only)	Ta=25°C 60-70%RH(Note 1)	20,000	-	-	Hr

Note 1: The LED Supply Voltage is defined by the number of LED at Ta=25°C and IL =300mA.

Note 2: The “LED life time” is defined as the module brightness decrease to 50% original brightness at Ta=25°C and IL =300mA. The LED lifetime could be decreased if operating IL is larger than 300mA.

Note 3: When the ADJ pin voltage rises from 0.7V_{DC} to 1.4V_{DC}, the LED current will change from 0% to 100% of the maximum LED current:

Analog Dimming Voltage

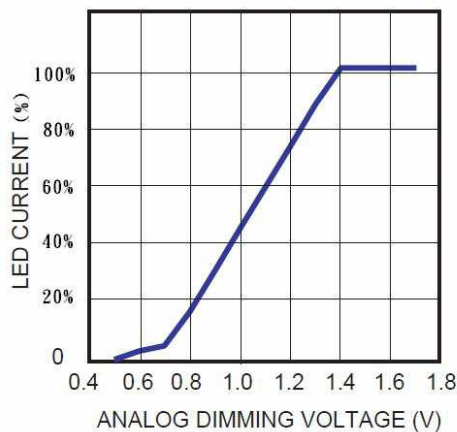

Note 4: ADJ signal V_{p-p} =1.4~5.0V, operation frequency: 100Hz ~ 1 kHz.

PWM Dimming Duty

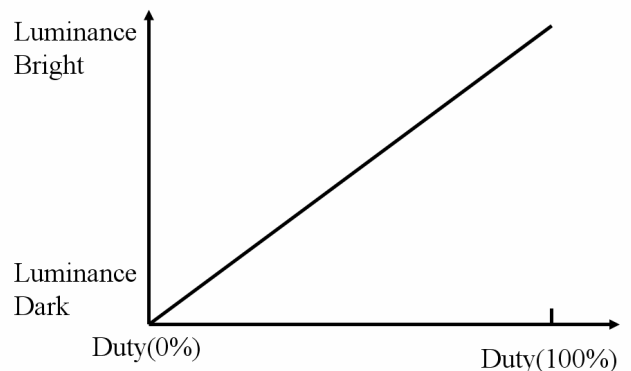
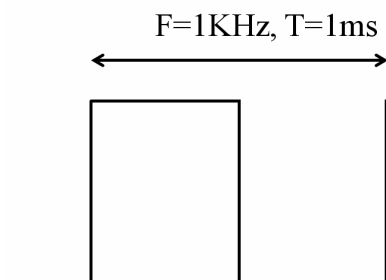

Note 5 : The figure below shows the connection of backlight LED.

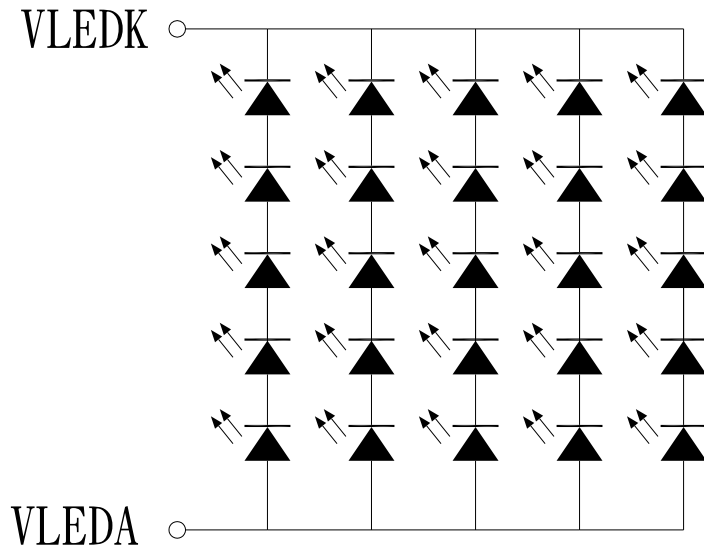

9. OPTICAL CHARACTERISTICS

Ta=25°C

ITEM	SYMBOL	CONDITIONS	MIN.	TYP.	MAX.	UNIT	REMARK
Contrast Ratio	CR	Viewing Normal Angle $\Theta_x = \Theta_y = 0^\circ$	400	500	-	-	Note (1)
Response Time	TR		-	10	20	ms	Note (2)
	TF		-	15	30	ms	
Chromaticity	White	x	(0.26)	(0.31)	(0.36)	-	Note (4)
		y	(0.28)	(0.33)	(0.38)	-	
Viewing Angle	Hor.	θ_{x+}	60	70	-	Deg.	Note (3)
		θ_{x-}	60	70	-		
	Ver.	θ_{y+}	40	50	-		
		θ_{y-}	60	70	-		
Luminance	L	PWM=100%	400	500	-	cd/m ²	
Luminance Uniformity	YU		70	75	-	%	Note (5)

*Note (1) Definition of Contrast Ratio (CR):

The contrast ratio can be calculated by the following expression.

$$\text{Contrast Ratio (CR)} = L_{63} / L_0$$

L63: Luminance of gray level 63

L 0: Luminance of gray level 0

$$\text{CR} = \text{CR} (5)$$

CR (X) is corresponding to the Contrast Ratio of the point X at Figure in Note (5).

*Note (2) Definition of Response Time (T_R , T_F):

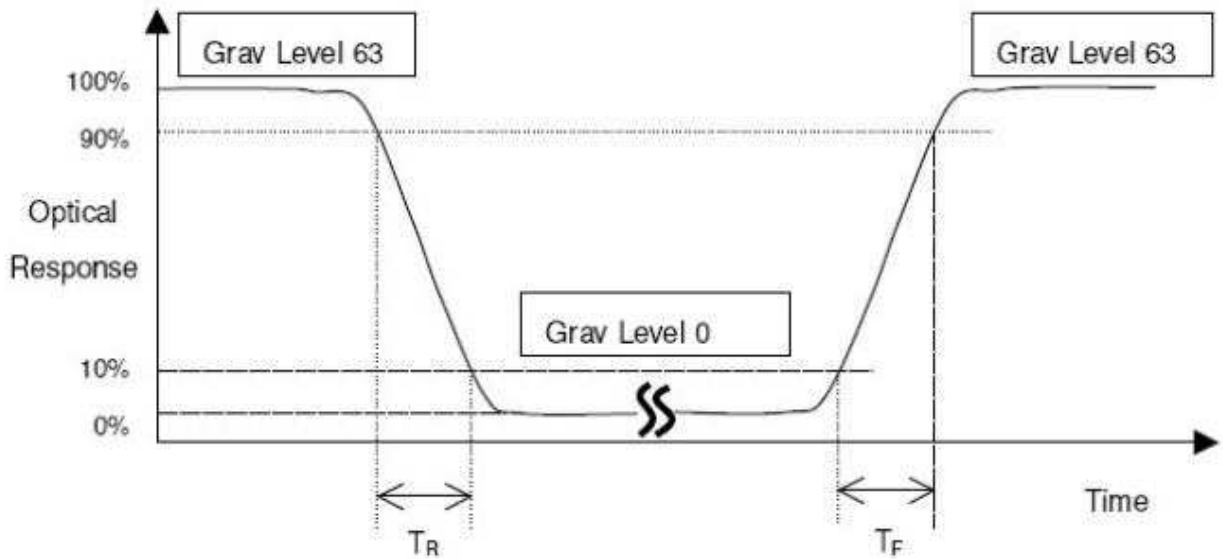

*Note(3) Definition of Viewing Angle

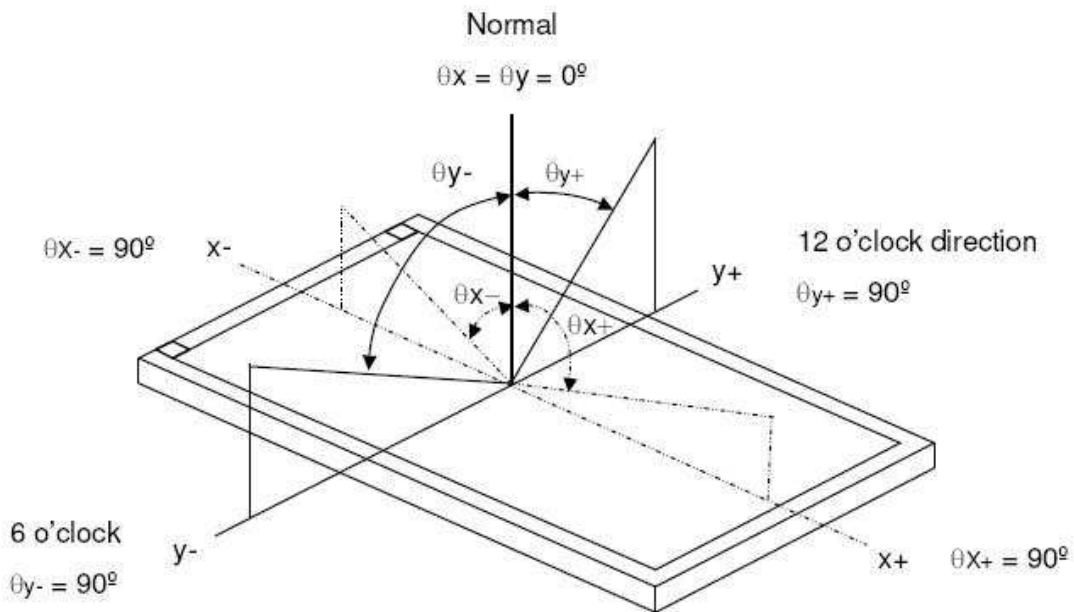

*Note (4) Measurement Set-Up:

The LCD module should be stabilized at a given temperature for 20 minutes to avoid abrupt temperature change during measuring. In order to stabilize the luminance, the measurement should be executed after lighting Backlight for 20 minutes in a windless room.

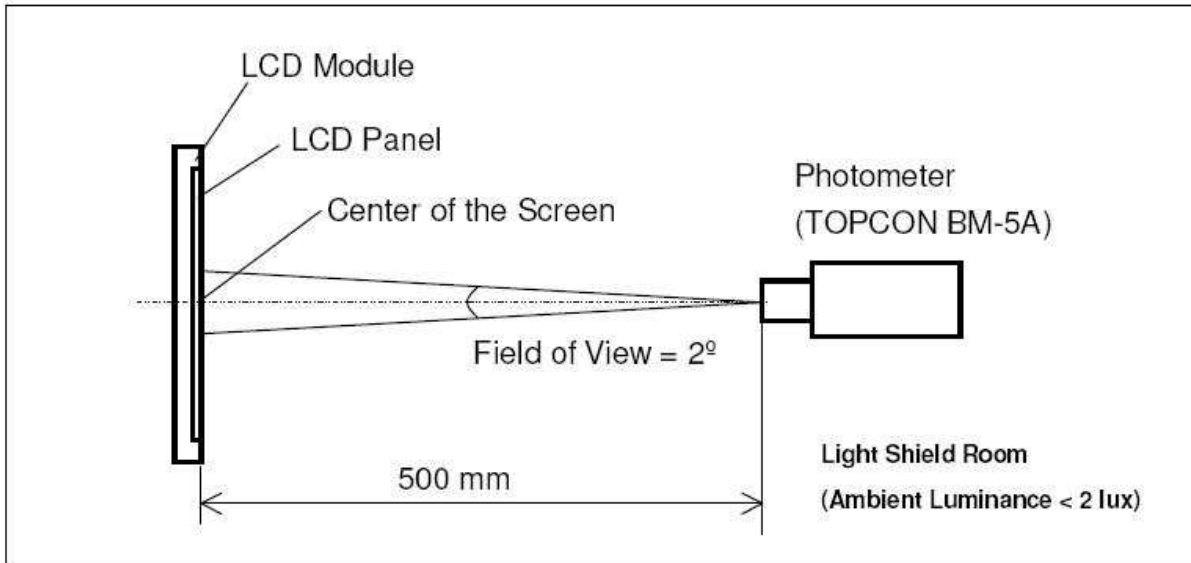

*Note (5)

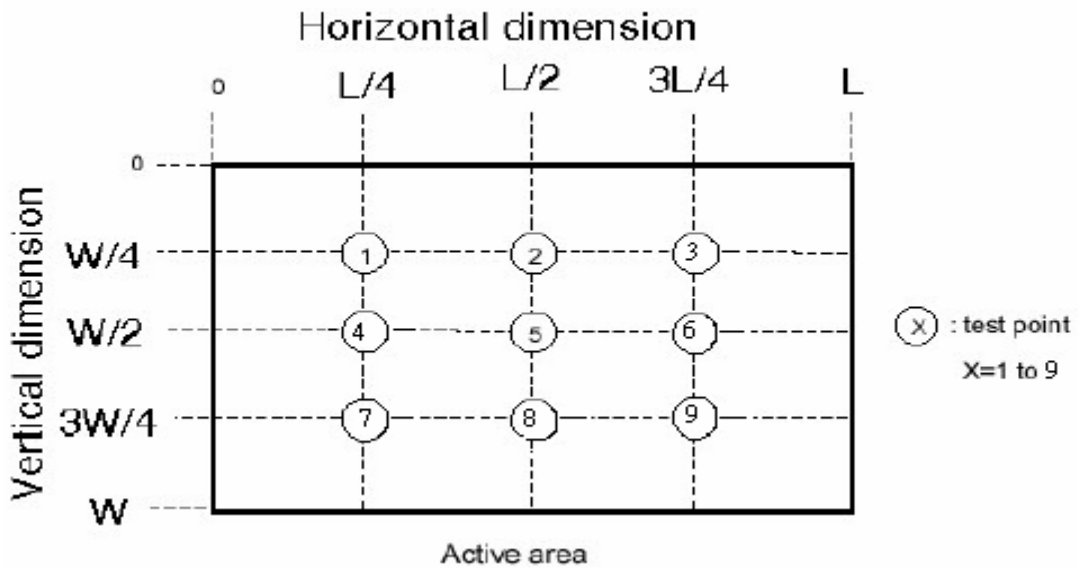

$$\left(1 - \frac{\text{MAX Luminance} - \text{Average Luminance}}{\text{Average Luminance}} \right) \times 100\% > 70\%$$

10. TIMING SPECIFICATIONS

10.1 POWER SIGNAL SEQUENCE

- $T1 \leq 10\text{ms}$; $1\text{sec} \leq T5$
- $200\text{ms} \leq T2$; $200\text{ms} \leq T6$
- $0 \leq T3 \leq 50\text{ms}$; $200\text{ms} \leq T7$
- $0 \leq T4 \leq 10\text{ms}$

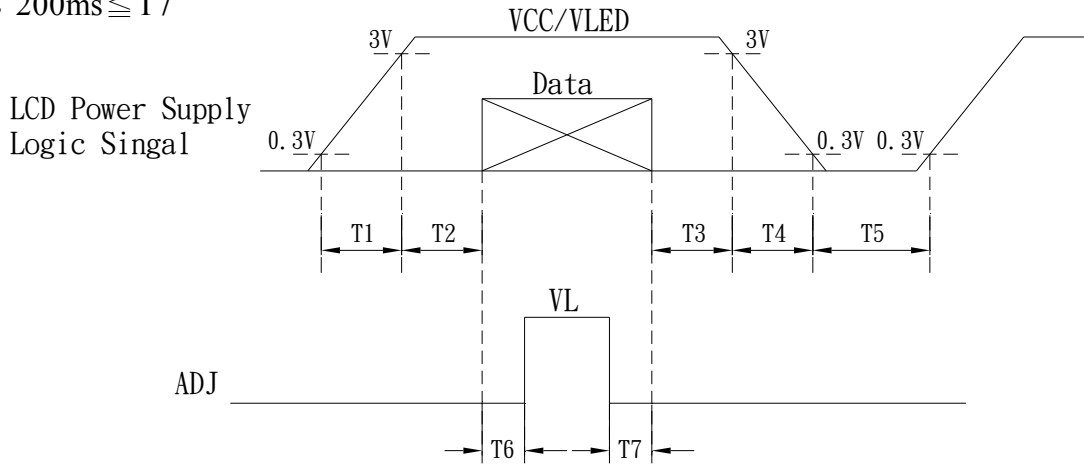

Data : RGB Data , DLCK , DE

10.2 THE INPUT DATA FORMAT

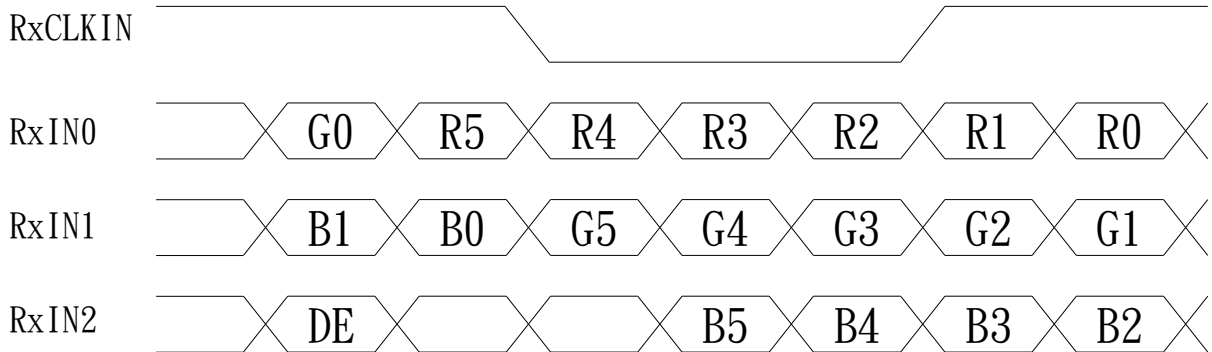

SIGNAL NAME	DESCRIPTION	REMARK
R5	Red Data 5	Red-pixel Data 6Bits LVDS input MSB : R5 ; LSB : R0
R4	Red Data 4	
R3	Red Data 3	
R2	Red Data 2	
R1	Red Data 1	
R0	Red Data 0	
G5	Green Data 5	
G4	Green Data 4	
G3	Green Data 3	
G2	Green Data 2	
G1	Green Data 1	
G0	Green Data 0	
B5	Blue Data 5	Blue-pixel Data 6Bits LVDS input MSB : B5 ; LSB : B0
B4	Blue Data 4	
B3	Blue Data 3	
B2	Blue Data 2	
B1	Blue Data 1	
B0	Blue Data 0	
RxCLKIN	LVDS Data Clock	
DE	Data Enable Signal	When the signal is high, the pixel data shall be valid to be displayed.

10.3 AC TIMING CHARACTERISTICS

PARAMETER	SYMBOL	MIN.	TYP.	MAX.	UNIT	REMARK
Clock	Frequency	1/Tc	31.95	33.26		Note 1
	Clk pulse duty	Tcwh	40	50	60	%
	Clk cycle time	Tcph	25	-	-	ns
Data	Setup time	Tdsu	5	-	-	ns
	Hold time	Tdhd	5	-	-	ns
ENAB signal	Setup time	Tesu	5	-	-	ns
	Hold time	Tehd	5			ns

Note 1 : Frame rate is 60 Hz at 3.3V VCC

Clock and Data Timing Diagram

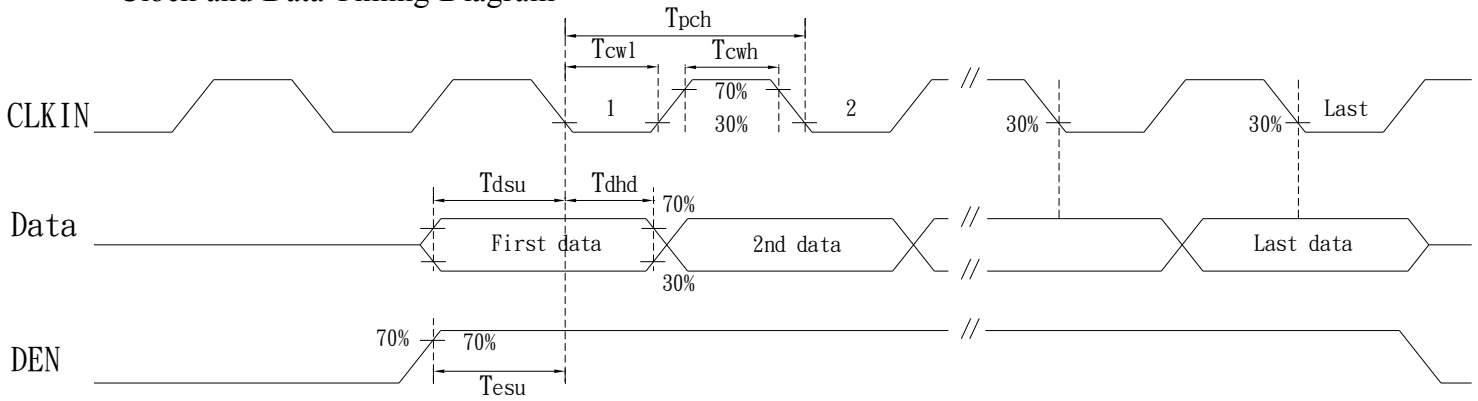

11. RELIABILITY TEST

ENVIRONMENTAL TEST				
NO.	ITEM	CONDITIONS	TIME PERIOD	REMARK
1	High Temperature Storage	80°C	240HRS	
2	Low Temperature Storage	-30±3°C	240HRS	
3	High Temperature Operation	80°C	240HRS	
4	Low Temperature Operation	-20°C	240HRS	
5	Temperature Cycle	-20°C ← 25°C → 80°C (30min) (5min) (30min)	100CYCLE	
6	High Temperature Humidity Operation	60°C 90%RH	240HRS	

NOTE 1: a. THE MODULE SHOULD WORK PROPERLY.

- b. BEFORE AND AFTER FUNCTION TEST, THE DIFFERENCE OF CONSUMPTIVE CURRENT SHOULD BE WITHIN 10%

NOTE 2 : a. THE MODULE SHOULD WORK PROPERLY.

- b. THE MODLUE WON'T BE DEFORMATIVE, COLOR CHANGEABLE OR BROKEN.
c. THE MODULES CAN'T BE APART.

NOTE 3 : a. BEFORE COSMETIC AND FUNCTION TEST, THE PRODUCT MUST HAVE ENOUGH RECOVERY TIME, AT LEAST 2 HOURS AT ROOM TEMPERATURE.

12. PRECAUTIONS FOR USE

12.1 SAFETY

- (1) Do not swallow any liquid crystal, even if there is no proof that liquid crystal is poisonous.
- (2) If the LCD panel breaks, be careful not to get liquid crystal to touch your skin.
- (3) If skin is exposed to liquid crystal, wash the area thoroughly with alcohol or soap.

12.2 STORAGE CONDITIONS

- (1) Store the panel or module in a dark place where the temperature is $23\pm 5^{\circ}\text{C}$ and the humidity is below $50\pm 20\%\text{RH}$.
- (2) Store in anti-static electricity container.
- (3) Store in clean environment, free from dust, active gas, and solvent.
- (4) Do not place the module near organics solvents or corrosive gases.
- (5) Do not crush, shake, or jolt the module.

12.3 HANDLING PRECAUTIONS

- (1) Avoid static electricity which can damage the CMOS LSI.
- (2) The polarizing plate of the display is very fragile. So, please handle it very carefully.
- (3) Do not give external shock.
- (4) Do not apply excessive force on the surface.
- (5) Do not wipe the polarizing plate with a dry cloth, as it may easily scratch the Surface of plate.
- (6) Do not use ketonics solvent & Aromatic solvent, use with a soft cloth soaked with a cleaning naphtha solvent.
- (7) Do not operate it above the absolute maximum rating.
- (8) Do not remove the panel or frame from the module.
- (9) When the module is assembled, it should be attached to the system firmly, Be careful not to twist and bend the module.
- (10) Wipe off water droplets or oil immediately . If you leave the droplets for a long time, staining and discoloration may occur.
- (11) If the liquid crystal material leaks from the panel, it should be kept away from the eyes or mouth. In case of contact with hands, legs or clothes, it must be washed away thoroughly with soap.

12.4 WARRANTY

(1) Acceptance inspection period

The period is within one month after the arrival of contracted commodity at the buyer's factory site.

(2) Applicable warrant period

The period is within 12 months since the date of shipping out under normal using and storage conditions.

The Netherlands



Elektrostraat 17
NL-7483 PG Haaksbergen

T: +31 (0)53 573 33 33
F: +31 (0)53 573 33 30
E: nl@texim-europe.com

Belgium



Zuiderlaan 14 bus 10
B-1731 Zellik

T: +32 (0)2 462 01 00
F: +32 (0)2 462 01 25
E: belgium@texim-europe.com

UK & Ireland



St. Mary's House, Church Lane
Carlton Le Moorland
Lincoln LN5 9HS

T: +44 (0)1522 789 555
F: +44 (0)845 299 22 26
E: uk@texim-europe.com

Germany North



Bahnhofstrasse 92
D-25451 Quickborn

T: +49 (0)4106 627 07-0
F: +49 (0)4106 627 07-20
E: germany@texim-europe.com

Germany South



Martin-Kollar-Strasse 9
D-81829 München

T: +49 (0)89 436 086-0
F: +49 (0)89 436 086-19
E: germany@texim-europe.com

Austria



Warwitzstrasse 9
A-5020 Salzburg

T: +43 (0)662 216 026
F: +43 (0)662 216 026-66
E: austria@texim-europe.com

Nordic region



Sdr. Jagtvej 12
DK-2970 Hørsholm

T: +45 88 20 26 30
F: +45 88 20 26 39
E: nordic@texim-europe.com

General information



info@texim-europe.com
www.texim-europe.com