

Front VIEW

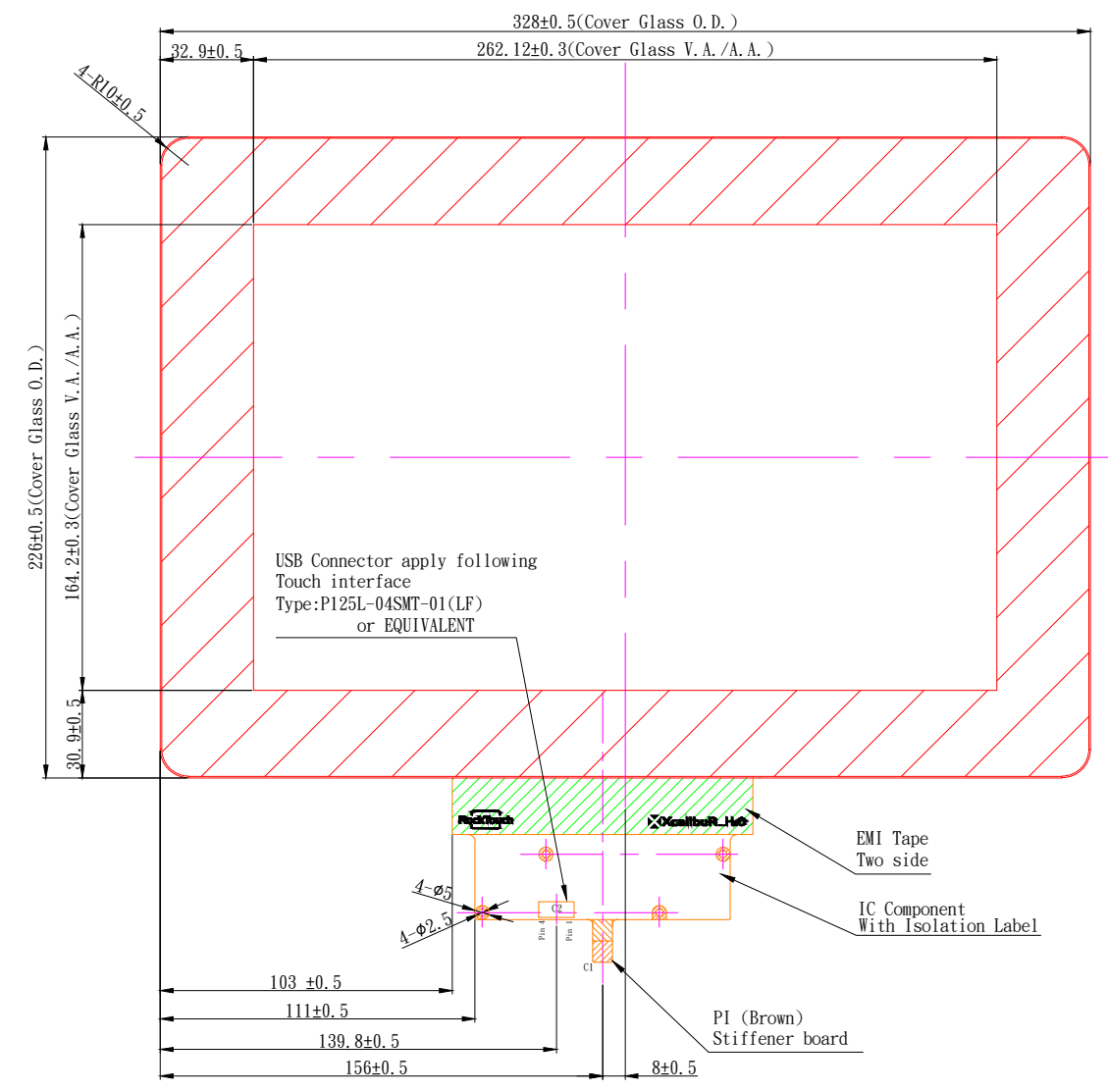

Back VIEW

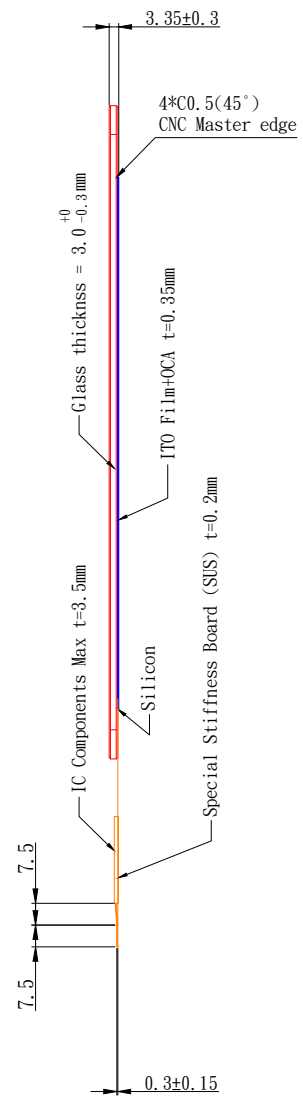
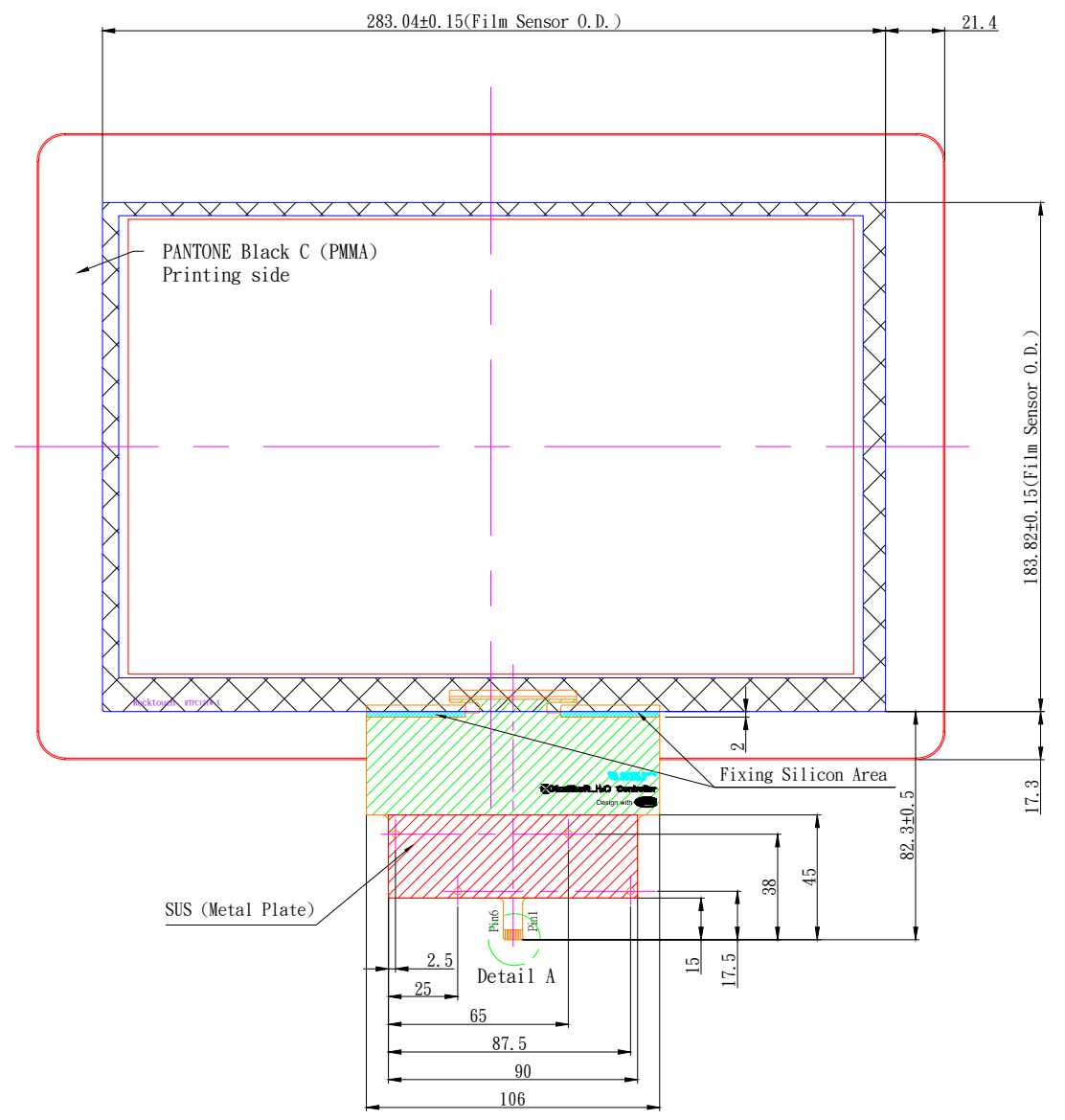

Printing Info :
 Background Printing Type : PMMA CERAMIC 700°C Background Color : Pantone Black C
 Logo Printing Type : PMMA Logo Color :

- Note:
- To choose the interface just add at the end of the part number the following : - U for USB - I for I2C
 - Tolerance: +-0.3mm
 - Finger input only or special conductive pen
 - Surface Hardness: 7H (Semi-Tempered Glass)
 - Transmittance: >85% (JIS-K7105)
 - Surface Treatment: None
 - Distance between LCD and touch panel need to be minimum 1.0mm otherwise touch maybe will not work correctly
 - If customer put a front cover all around need use at least 2mm thick gasket between touch and metal frame
 - USB max ripple acceptable is 50mV, in other case touch will not work correctly
 - Referring to the integration guide to avoid any integration noise issue

C1:USB (OPTIONAL)	
Pin 01	GND
Pin 02	D-
Pin 03	D+
Pin 04	VDD
Pin 05	NC
Pin 06	RST

C1:I2C (OPTIONAL)	
Pin 01	GND
Pin 02	SDA
Pin 03	SCL
Pin 04	VDD
Pin 05	INT
Pin 06	RST

C2:Pin Define for USB 4 pin	
Pin 01	GND
Pin 02	D-
Pin 03	D+
Pin 04	VDD

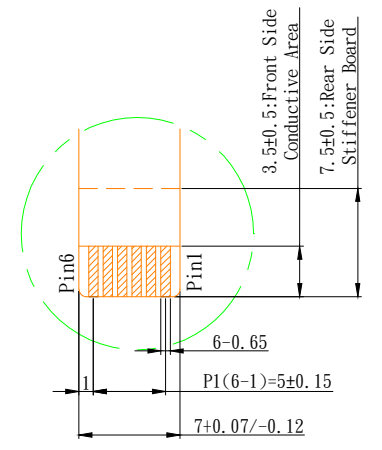

Detail A

Customer Approval		Part Number		RTPC121W-H30BP1	
Date		Rev. Date	Person	Description	
Company Name		01	20160620 Kevin	Correct Interface Information	
Signature		Date	Design By	Date	Check By
		First Drawing	20160526 Jeff	20160531 Kevin	Approved By

