



# LCD Module

## Product Specification

: APPROVAL FOR SPECIFICATION

For Customer : \_\_\_\_\_  : APPROVAL FOR SAMPLE

Module No. : TST070CBOT-01P

For Customer's Acceptance :

Approved by	Comment

Team Source Display :

Presented by	Reviewed by	Organized by

This module uses ROHS material

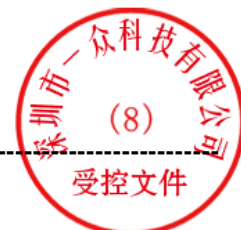

# Contents

<b>1.0 General description</b>	
<b>2.0 Absolute maximum ratings</b>	
<b>3.0 Optical characteristics</b>	
<b>4.0 Block diagram</b> .....	
<b>5.0 Interface pin connection</b> .....	<b>p.</b>
<b>6.0 Electrical characteristics</b> .....	
<b>7.0 Reliability test items</b> .....	<b>p.</b>
<b>8.0 Precautions</b> .....	<b>p.</b>
<b>9.0 Outline dimension</b> .....	
<b>10.0 Lot mark</b> .....	<b>p.22</b>
<b>11.0 Package specification</b> .....	<b>p.23</b>

## 1.0 GENERAL DESCRIPTION

### 1.1 Introduction

Team Source Display TST070CBOT-01P is a color active matrix thin film transistor(TFT) liquid crystal display (LCD) that uses amorphous silicon TFT as a switching device. This model is composed of a TFT LCD panel, a driving circuit and a back light system. This TFT LCD has a 7.0 (16:9) inch diagonally measured active display area with WVGA (800 horizontal by 480 vertical pixel) resolution.

### 1.2 Features

- 7.0 (16:9 diagonal) inch configuration.
- 6 bits + FRC driver with 1 channel TTL interface
- LED Backlight
- Up/Down, Left/Right reversion selection
- Resistive Touch Panel with 96% Transmittance**

### 1.3 Applications

- Mobile NB
- Digital Photo frame
- Multimedia applications and Others AV system

### 1.4 General information

Item	Specification	Unit
Screen Size	7.0 inches	Diagonal
Number of Pixel	800 RGB (H) x 480(V)	Pixels
Display area	154.00(H) x 85.92(V)	mm
Outline Dimension	164.90 x 100.00 x 4.70 (Typ)	mm
Display mode	Normally white	--
Pixel arrangement	RGB Vertical stripe	--
Pixel pitch	0.0632(H) x 0.179(V)	mm
Back-light	LED Side-light type	--
Surface treatment	Antiglare, Hard-Coating (3H) with EWV film	--

### 1.5 Mechanical Information

Item		Min.	Typ.	Max.	Unit
Module Size	Horizontal (H)	164.60	164.9	165.20	mm
	Vertical (V)	99.70	100.0	100.30	mm
	Depth (D)	--	4.70	4.85	mm

## 2.0 ABSOLUTE MAXIMUM RATINGS

### 2.1 Electrical Absolute Rating

#### 2.1.1 TFT LCD Module

Item	Symbol	Min	Max	Unit	Note
Power supply voltage	VCC	-0.3	6.0	V	GND=0
	VDH	0.3	40	V	GND=0
	VGL	-20	0.3	V	GND=0
	AVDD	0.5	15	V	AGND=0
	VCOM	0	6	V	
Logic Signal Input Level	Vi	-0.3	VDD +0.3	V	

#### 2.1.2 Back-Light Unit

Item	Symbol	Typ	Max	Unit	Note
LED current	IL	40	--	mA	(1)(2)(3)
LED voltage	VL	21	22.4	V	(1)(2)(3)

#### Note

- (1) Permanent damage may occur to the LCD module if beyond this specification. Functional operation should be restricted to the conditions described under normal operating conditions.
- (2) Ta =25±2°C

### 2.2 Environment Absolute Rating

Item	Symbol	Min.	Max.	Unit	Note
Storage temperature	T <sub>STG</sub>	-30	80	°C	
Operating temperature	T <sub>OPR</sub>	-20	70	°C	

### 3.0 OPTICAL CHARACTERISTICS

#### 3.1 Optical specification

Item	Symbol	Condition	Min	Type	Max	Unit	Note
White luminance (Center)	YL	$\Theta=0$ Normal Viewing Angle		260		cd/m <sup>2</sup>	(1)(4)(6) (I L=40mA)
Response time	T <sub>r</sub>		-	5	7	msec	(1)(3)
	T <sub>f</sub>		--	20	28		
Contrast ratio	CR		--	700	--	--	(1)(2)
Color Chromaticity (CIE 1931)	white	W <sub>x</sub>	0.260	0.310	0.360		
		W <sub>y</sub>	0.280	0.330	0.380		
Viewing Angle	Hor.	$\Theta_L$	60	75	--		(1)(4)
		$\Theta_R$	60	75	--		
	Ver.	$\Theta_U$	60	75	--		
		$\Theta_D$	50	70	--		
Brightness uniformity	B <sub>UNI</sub>	$\Theta=0$	70	--	--	%	(6)
Optima View Direction			6	o'clock			(5)

#### 3.2 Measuring Condition

Measuring surrounding: dark room

LED current I<sub>L</sub>: 40mA

Ambient temperature: 25±2°C

15min. warm-up time

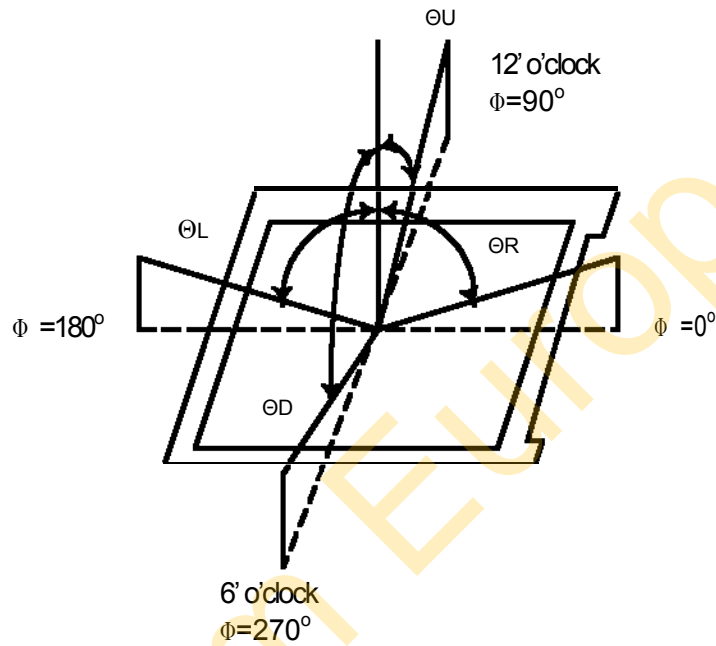
**Note (1) Definition of Viewing Angle****Note (2) Definition of Contrast Ratio(CR):  
Measured at the center point of panel**

$$CR = \frac{\text{Luminance with all pixels white}}{\text{Luminance with all pixels black}}$$

**Note (3) Definition of Response Time: Sum of  $T_R$  and  $T_F$**

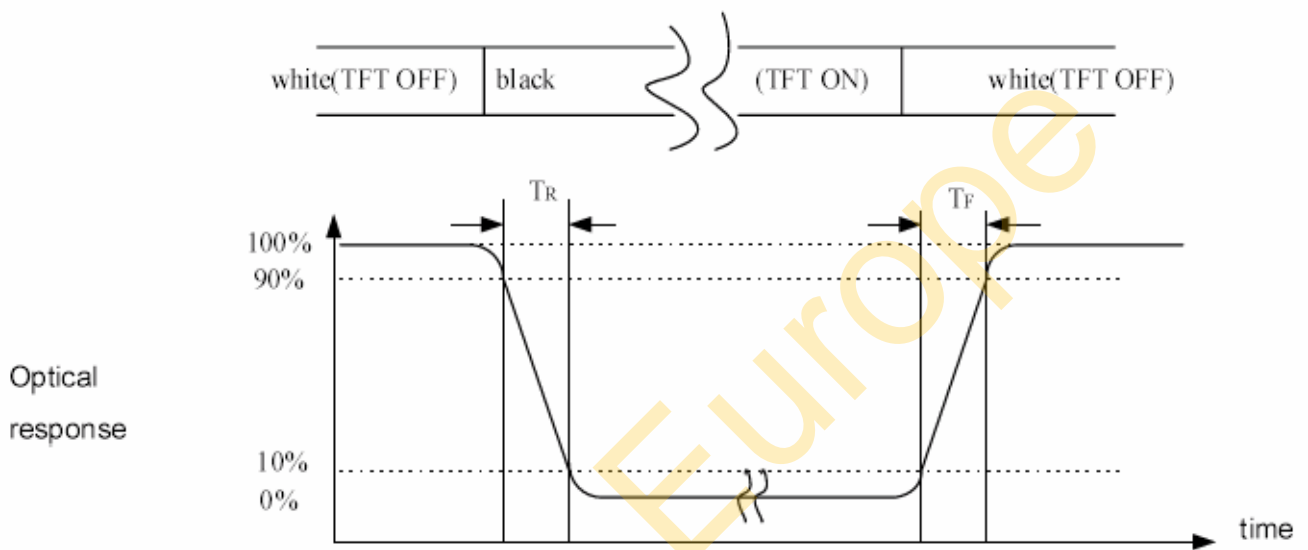

**Note (4) Definition of optical measurement setup**

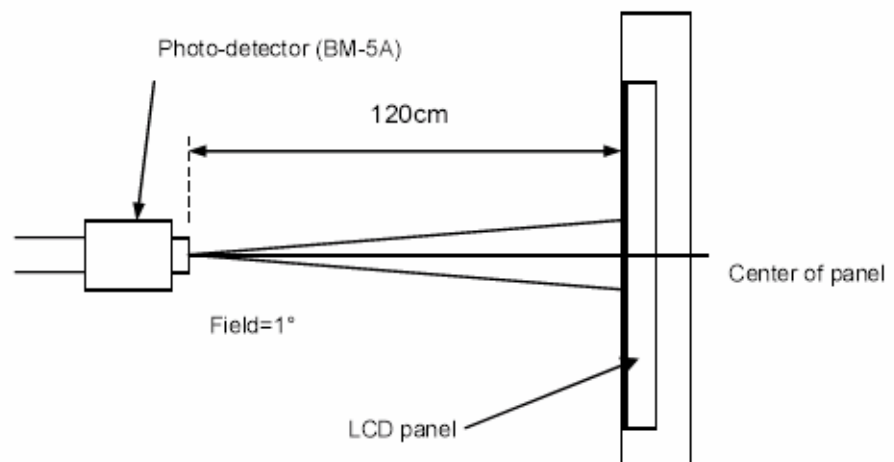

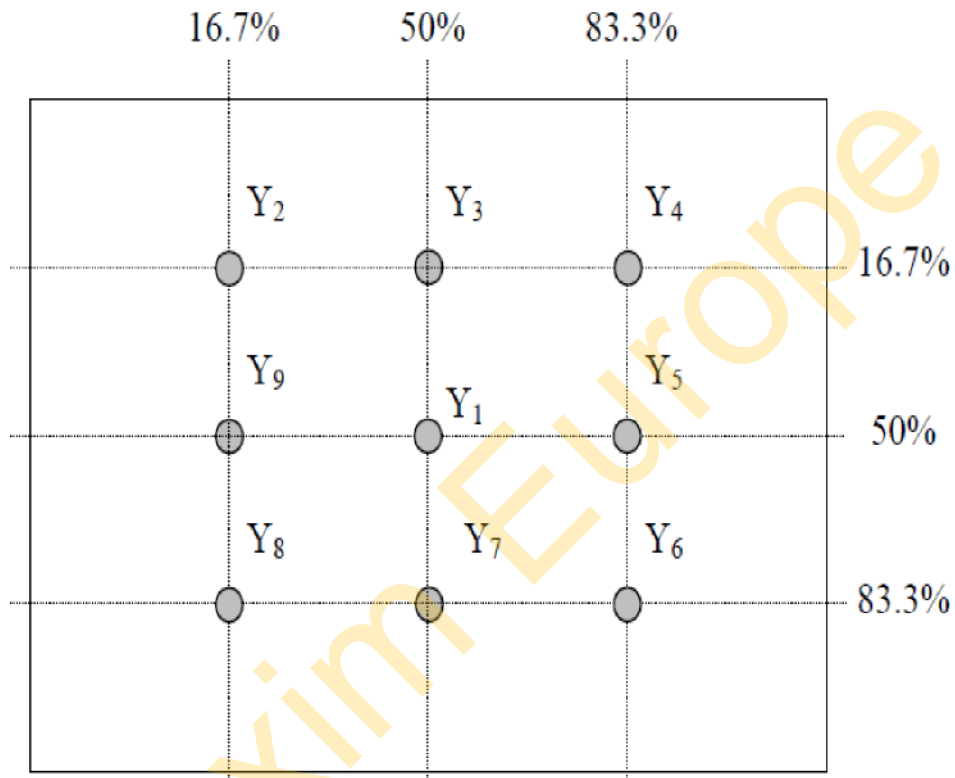
**Note (5) Definition of brightness uniformity**

$$\text{Luminance uniformity} = \frac{\text{(Min Luminance of 9 points)}}{\text{(Max Luminance of 9 points)}} \times 100 \%$$

**Note (6) Rubbing Direction** (The different Rubbing Direction will cause the different optima view direction.)

**Note (7)** Measured at the brightness of the panel when all terminals of LCD panel are electrically open.



### 4.0 BLOCK DIAGRAM

#### 4.1 TFT LCD Module

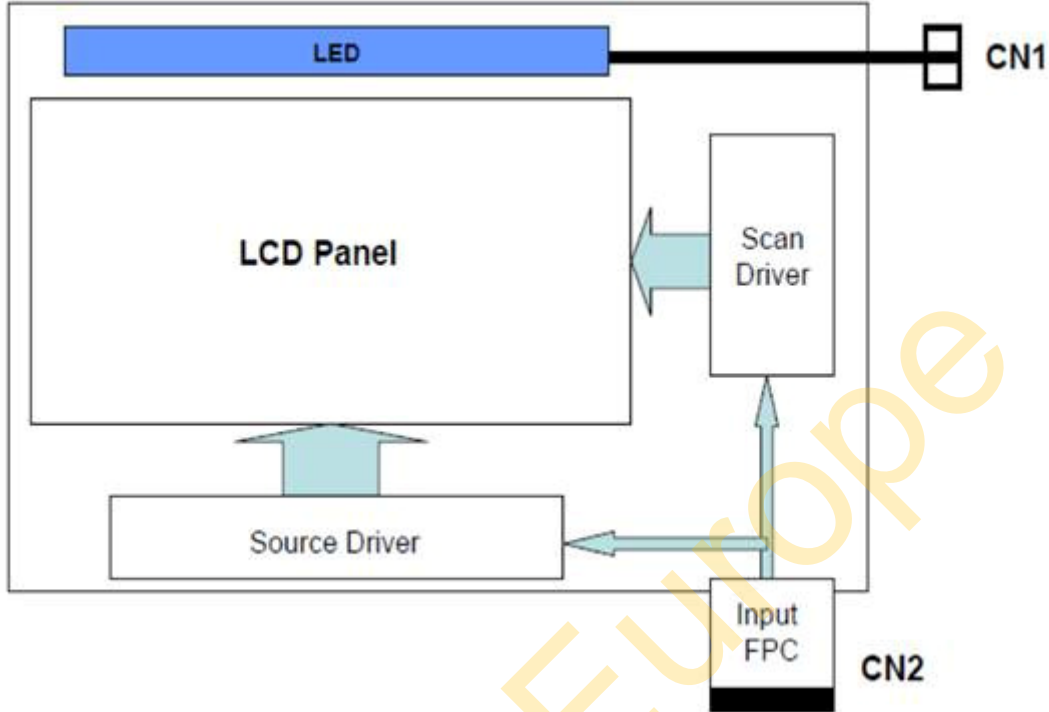

#### 4.2 Pixel Format

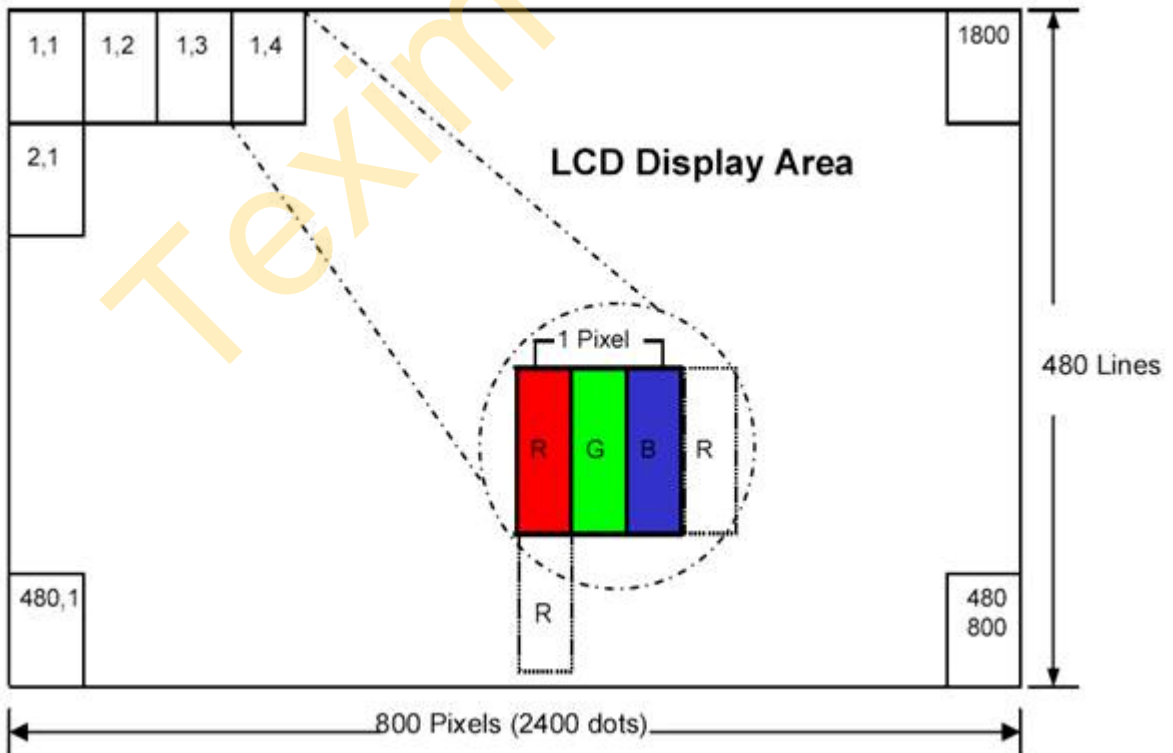

## 5.0 INPUT INTERFACE PIN ASSIGNMENT

### 5.1 TFT LCD Module

CN2(Input signal): FPC Down Connector,(FH28-40S-0.5SH (HIROSE),60pin,pitch=0.5mm)

Pin No.	Symbol	Function
1	VLED-	LED Power Cathode
2	VLED+	LED Power Anode
3	GND	Analog Ground
4	Vcc	Power supply
5	R0	Input data Red
6	R1	Input data Red
7	R2	Input data Red
8	R3	Input data Red
9	R4	Input data Red
10	R5	Input data Red
11	R6	Input data Red
12	R7	Input data Red
13	G0	Input data Green
14	G1	Input data Green
15	G2	Input data Green
16	G3	Input data Green
17	G4	Input data Green
18	G5	Input data Green
19	G6	Input data Green
20	G7	Input data Green
21	B0	Input data Blue
22	B1	Input data Blue
23	B2	Input data Blue
24	B3	Input data Blue
25	B4	Input data Blue
26	B5	Input data Blue
27	B6	Input data Blue
28	B7	Input data Blue
29	DGND	Ground
30	CLK	clock signal
31	DISP	Display on/of
32	HSYNC	Horizontal sync input in RGB mode

33	VSYNC	Vertical sync input in RGB mode
34	DE	Data enable
35	NC	No Connection
36	GND	Ground
37	X_R	Touch panel X-right
38	Y_D	Touch panel Y-bottom
39	X_L	Touch panel X-left
40	Y_U	Touch panel Y-up

## 6.0 ELECTRICAL CHARACTERISTICS

### 6.1 TFT LCD Module

Item	Symbol	Min.	Typ.	Max.	Unit	Note
Supply voltage	VCC	2.7	3.0	3.5	V	
	VGH	14.5	15	20	V	
	VGL	-10	-7	-6.5	V	
	AVDD	9.85	10	10.15	V	
VCOM	VCOMin	--	3.9	--	V	
Input signal Voltage	VIH	0.7 VCC	-	VCC	V	Note (1)
	VIL	0	-	0.3 VCC	V	
Current Power Supply	IDD	--	5.426	--	mA	VCC =3.3V
	IADD	--	24.1	--	mA	AVDD=10V(Black)
	IGH	--	0.128	--	mA	VGH=15V
	IGL	--	0.344	--	mA	VGL= -7V
Input level of V1~V5	Vx	AVDD/2-	-	AVDD-0.1-	V	
Input level of V6~V10	Vx	0.1-		AVDD/2-	V	

**Note (1): HSYNC, VSYNC, DE, R/G/B Data**

**Note (2): Be sure to apply the power Voltage as the power sequence spec.**

**Note (3): GND=0V**

### 6.2 Back-Light Unit

The backlight system is an edge-lighting type with 14LED.

The characteristics of the LED are shown in the following tables.

Item	Symbol	Min	Typ	Max	Unit	Note
LED current	IL	-	40	-	mA	(2)
LED voltage	VL	-	22.4		V	
Operating LED life time	Hr	30000	50000	-	Hour	(1)(2)

Note (1) LED life time (Hr) can be defined as the time in which it continues to operate under the condition:  $T_a=25\pm 3\text{ }^\circ\text{C}$ , typical IL value indicated in the above table until the brightness becomes less than 50%.

Note (2) The "LED life time" is defined as the module brightness decrease to 50% original brightness at  $T_a=25^\circ\text{C}$  and  $IL=40\text{mA}$ . The LED lifetime could be decreased if operating IL is larger than 40 mA. The constant current driving method is suggested.

### 6.3 AC Characteristics

Item	Symbol	Min.	Typ.	Max.	Unit.	Remark
DCLK cycle time	Tclk	25	-	-	ns	
DCLK frequency	Fclk	-	30	40	MHz	
DCLK pulse duty	Tcwh	40	50	60	%	
VSD setup time	Tvst	8	-	-	ns	
VSD hold time	Tvhd	8	-	-	ns	
HSD setup time	Thst	8	-	-	ns	
HSD hold time	Thhd	8	-	-	ns	
Data setup time	Tdasu	8	-	-	ns	
Data hold time	Tdahd	8	-	-	ns	
DE setup time	Tdesu	8	-	-	ns	
DE hold time	Tdehd	8	-	-	ns	
Horizontal display area	Thd		800	-	Tcph	
HSD period time	Th		928	-	Tcph	
HSD width	Thwh	1	48	-	Tcph	
HSD back porch	Thbp		40	-	Tcph	
HSD front porch	Thfp		40	-	Tcph	
Vertical display area	Tvd		480	-	th	
VSD period time	Tv		525	-	th	
VSD width	Tvwh		3	-	th	
VSD back porch	Tvbp		29	-	th	
VSD front porch	Tvfp		13	-	th	

### 6.4 Timing Diagram of Interface Signal

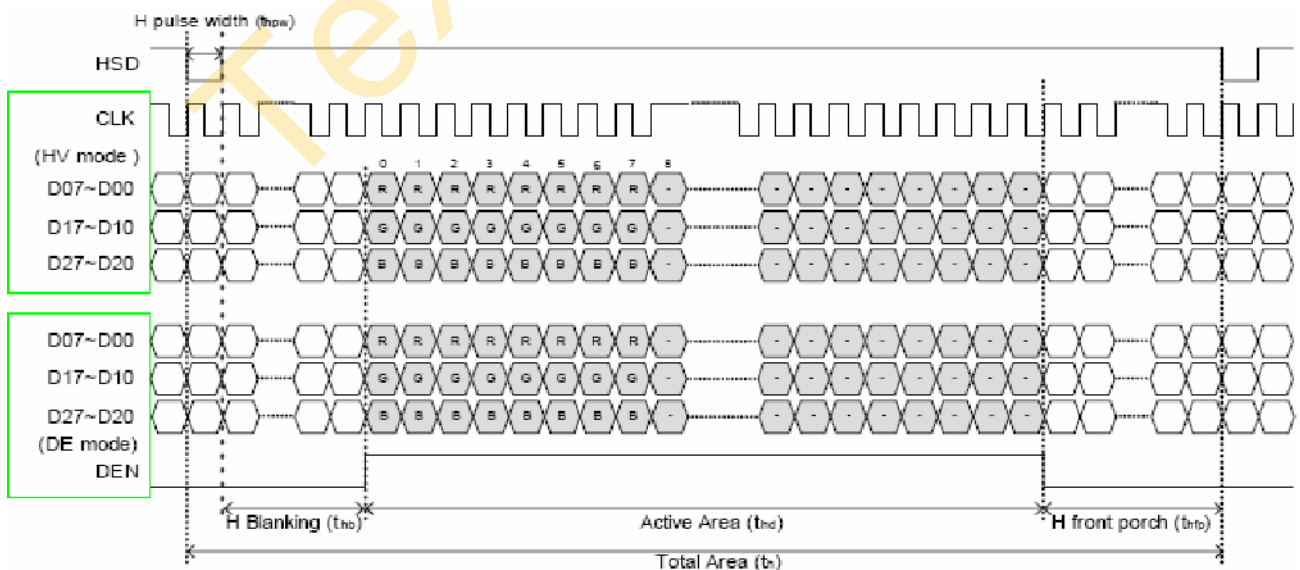
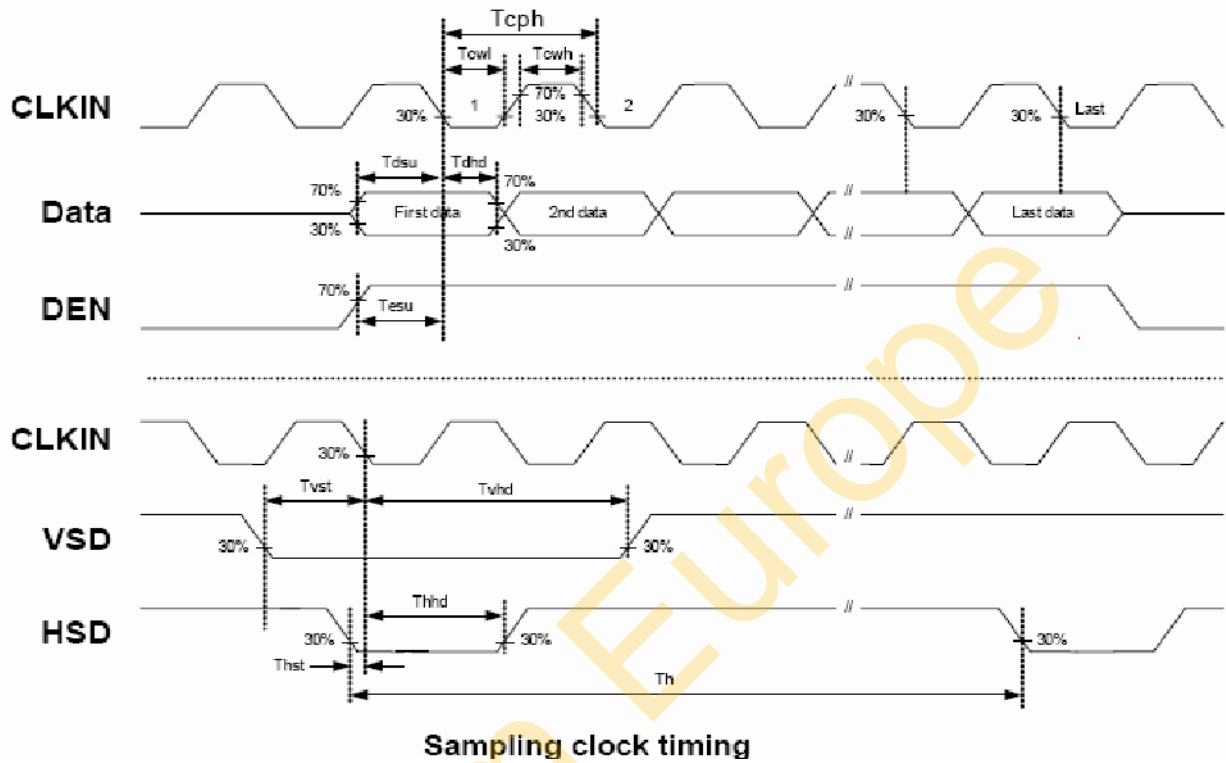

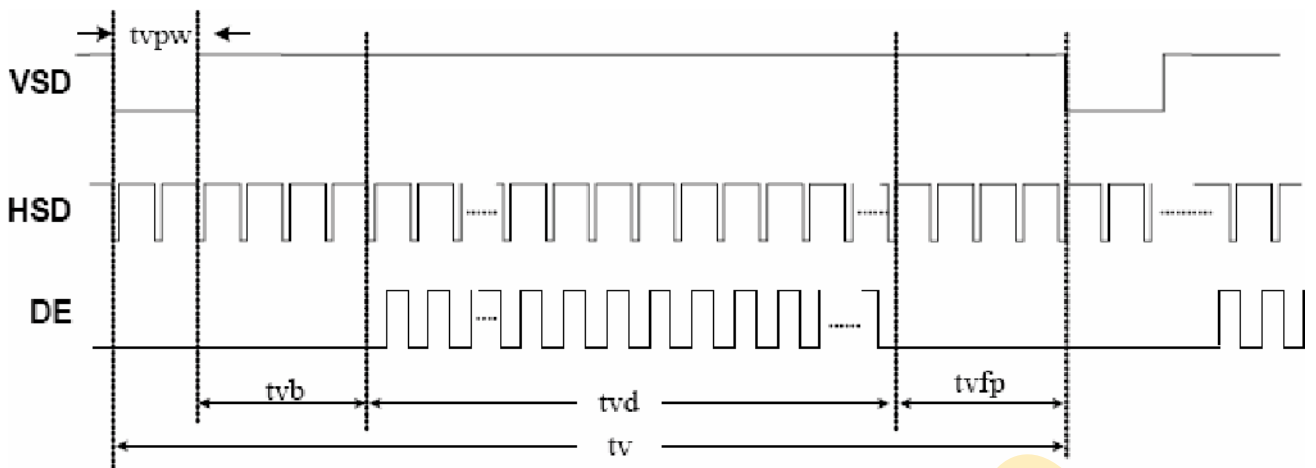

Vertical timing

6.5 Power Sequence

6.5 Power Sequence

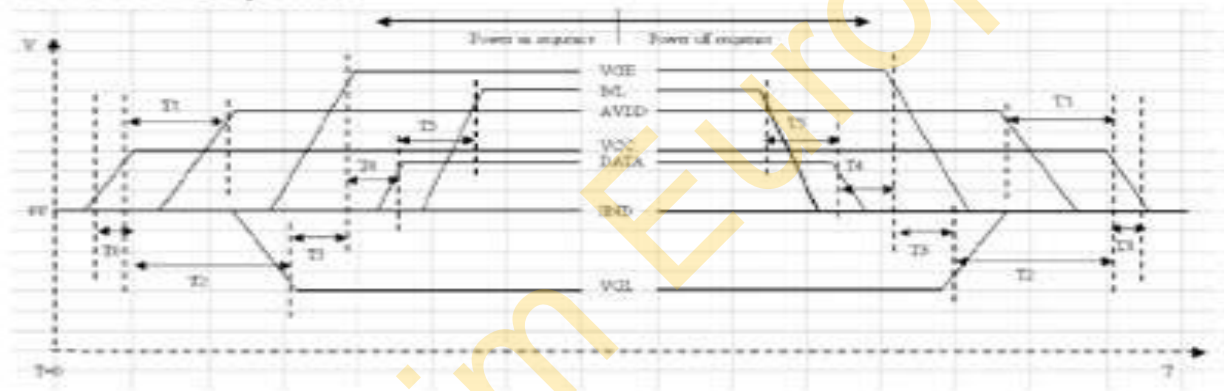

Item	Min.	Typ.	Max.	Unit
T0	0.5	-	20	msec
T1	16			msec
T2	20			msec
T3	10			msec
T4	10		50	msec
T5	50			msec

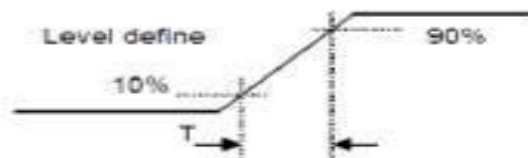

Power On Sequence: VCC -> AVDD -> VGL -> VGH -> Data -> B/L  
 Power Off Sequence: B/L -> Data -> VGH -> VGL -> AVDD -> VCC

Notes : Data include R0~R7, G0~G7, B0~B7, HSD, VSD, DCLK, SHLR, UPDN, DE MODE, RSTB, STBYB, SHLR, UPDN, DITH

## 7.0 RELIABILITY TEST ITEMS

No.	Item	Conditions	Notes
1	High Temperature Storage	Ta=+80°C, 240hrs	
2	Low Temperature Storage	Ta=-30°C, 240hrs	
3	High Temperature Operation	Ta=+70°C, 240hrs	
4	Low Temperature Operation	Ta=-20°C, 240hrs	
5	High Temperature and High Humidity (operation)	Ta=+60°C 90%RH, 240hrs	
6	Thermal Cycling Test (non operation)	-30°C(30min) → +80°C(30min), 200cycles	
7	Electrostatic Discharge	±200V,200pF(0Ω) 1 time/each terminal	
8	Vibration	1 .Random: 1 .04Grms, 5~500Hz, X/Y/Z, 30min/each direction 2. Sine: Freq. Range: 8~33.3Hz Stoke: 1.3mm Sweep: 2.9G, 33.3~400Hz X/Z: 2hr, Y: 4hr, cyc: 15min	
9	Shock	100G, 6ms, ±X, ±Y, ±Z 3 time for each direction	JIS C7021, A-10 (Condition A)
10	Vibration (with carton)	Random: 0.015G <sup>2</sup> /Hz, 5~200Hz -6dB/Octave, 200~400Hz XYZ each direction: 2hr	
11	Drop (with carton)	Height: 60cm 1 corner, 3 edges, 6 surfaces	JIS Z0202

**Note: There is no display function NG issue occurred, all the cosmetic specification is judged before the reliability stress.**



## 8. Handling Precautions

### 8.1 Mounting method

A panel of LCD module made by TS Display consists of two thin glass plates with polarizers that easily get damaged. When doing the mounting of the LCD module, extreme care should be used when handling the LCD modules.

### 8.2 Cautions of LCD handling and cleaning

When cleaning the display surface, use soft cloth with solvent (recommended below) and wipe lightly.

- Isopropyl alcohol
- Ethyl alcohol
- Trichlorotrifluoroethane

Do not wipe the display surface with dry or hard materials that will damage the polarizer surface.

Do not use the following solvent:

- Water
- Ketene
- Aromatics

### 8.3 Caution against static charge

The LCD module use C-MOS LSI drivers. So we recommend you:

Connect any unused input terminal to  $V_{dd}$  or  $V_{ss}$ . Do not input any signals before power is turned on, and ground your body, work/assembly areas, assembly equipment to protect against static electricity.

### 8.4 Packaging

- Module employs LCD elements, and must be treated as such. Avoid intense shock and falls from a height.
- To prevent modules from degradation, do not operate or store them exposed direct to sunshine or high temperature/humidity.

### 8.5 Caution for operation

-It is an indispensable condition to drive LCD module within the limits of the specified voltage since the higher voltage over the limits may cause the shorter life of LCD module.

-An electrochemical reaction due to DC (direct current) causes LCD undesirable deterioration so that the uses of DC (direct current) drive should be avoided.

-Response time will be extremely delayed at lower temperature than the operating temperature range and on the other hand at higher temperature LCD module may show dark color in them. However those phenomena do not mean malfunction or out of order of LCD module, which will come back in the specified operating temperature.

### 8.6 Storage

In the case of storing for a long period of time, the following ways are recommended:

- Storage in polyethylene bag with the opening sealed so as not to enter fresh air outside in it. And with not desiccant.
- Placing in a dark place where neither exposure to direct sunlight nor light is. Keeping the storage temperature range.
- Storing with no touch on polarizer surface by any thing else.

### 8.7 Safety

-It is recommendable to crash damaged or unnecessary LCD into pieces and to wash off liquid crystal by either of solvents such as acetone and ethanol, which should be burned up later.

-When any liquid leaked out of a damaged glass cell comes in contact with your hands, please wash it off well at once with soap and water.

### 9.0 Outline dimension

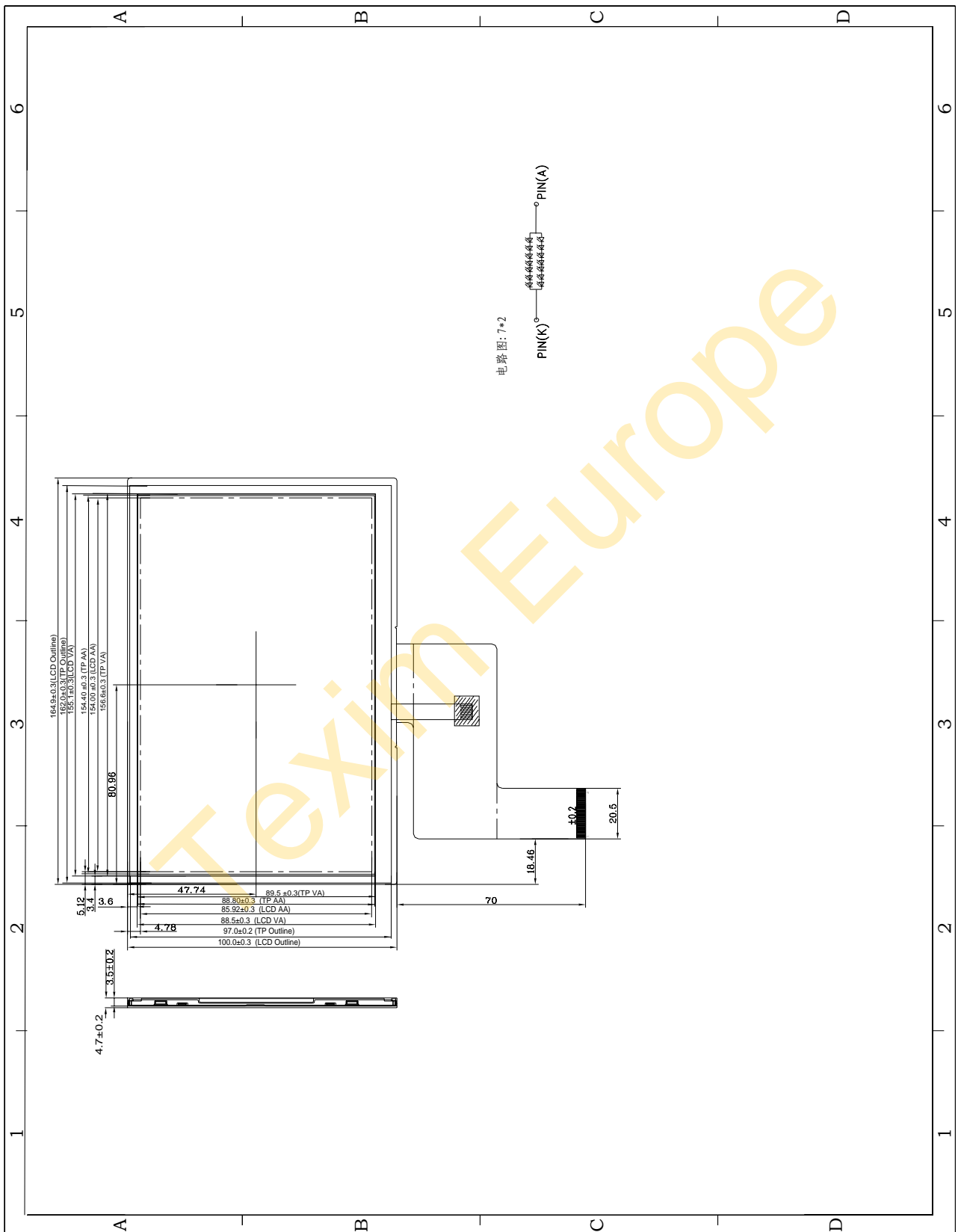

## The Netherlands



Elektrostraat 17  
NL-7483 PG Haaksbergen

T: +31 (0)53 573 33 33  
F: +31 (0)53 573 33 30  
E: [nl@texim-europe.com](mailto:nl@texim-europe.com)

## Belgium



Zuiderlaan 14 bus 10  
B-1731 Zellik

T: +32 (0)2 462 01 00  
F: +32 (0)2 462 01 25  
E: [belgium@texim-europe.com](mailto:belgium@texim-europe.com)

## UK & Ireland



St. Mary's House, Church Lane  
Carlton Le Moorland  
Lincoln LN5 9HS

T: +44 (0)1522 789 555  
F: +44 (0)845 299 22 26  
E: [uk@texim-europe.com](mailto:uk@texim-europe.com)

## Germany North



Bahnhofstrasse 92  
D-25451 Quickborn

T: +49 (0)4106 627 07-0  
F: +49 (0)4106 627 07-20  
E: [germany@texim-europe.com](mailto:germany@texim-europe.com)

## Germany South



Martin-Kollar-Strasse 9  
D-81829 München

T: +49 (0)89 436 086-0  
F: +49 (0)89 436 086-19  
E: [germany@texim-europe.com](mailto:germany@texim-europe.com)

## Austria



Warwitzstrasse 9  
A-5020 Salzburg

T: +43 (0)662 216 026  
F: +43 (0)662 216 026-66  
E: [austria@texim-europe.com](mailto:austria@texim-europe.com)

## Nordic region



Sdr. Jagtvej 12  
DK-2970 Hørsholm

T: +45 88 20 26 30  
F: +45 88 20 26 39  
E: [nordic@texim-europe.com](mailto:nordic@texim-europe.com)

## General information



[info@texim-europe.com](mailto:info@texim-europe.com)  
[www.texim-europe.com](http://www.texim-europe.com)