



### Features

- 10.1" New Generation Stainless Steel Panel PC
- Freescale I.MX6 DualLite 1.0GHz Onboard Processor
- True Flat Front Bezel Design and Grade 304 Stainless Steel Enclosure (Grade 316 for Option)
- IP66/IP69K Rated with M12 Connectors
- Support Resistive Touch, Projected Capacitive Touch, and Glass
- Touch on/off Button on the Side Edge for Hygienic Cleaning
- Support Ergonomic Versatile Mounting: Yoke Mounting / Space-saving VESA 75 mm Mounting



### Specifications

System	
Processor	Freescale I.MX6 DualLite 1.0GHz
System Chipset	SoC
System Memory	Onboard 1GB DDR3 DRAM
RFID Module	RFID Module design on the front side (optional)

Outside I/O Port – Standard M12 I/O Connector on the Rear Side	
USB	1 x M12 8-pin for USB 2.0 with waterproof cap
Serial/Parallel	1 x M12 8pin for COM 1, RS-232/422/485, Default RS-232, with waterproof cap
LAN	1 x M12 8pin for LAN with waterproof cap
Others	1 x Touch on/off button on the side
Option	1 x CAN via TB-508CAN1 1 x POE via AG5300

Storage Space	
Storage	Onboard 4GB eMMC NAND Flash

Expansion	
Expansion Slot	1 x Mini PCIe slot for WIFI/BT (optional)

Display	Standard	High Brightness optional
Display Type	10.1" color TFT LCD	10.1" color TFT LCD
Max. Resolution	1280 x 800	1280 x 800
Max. Color	16.7M	16.7M
Luminance (cd/m <sup>2</sup> )	350	1000
View Angle	170(H) / 170(V)	170(H) / 170(V)
Contrast	800:1	800:1
Backlight Lifetime	15,000 Hrs	30,000 Hrs
Option	Optical Boading	Optical Boading

Touch Screen	Resistive Touch	PCT	Glass
TS Control IC	PenMount 6000 on Board	Chip on tail	NA
Interface	USB interface	USB interface	AR
Light Transmission	Over 80%	Over 90%	Over 90%

Power	
Power input	9~36V DC
Power Consumption	MAX: 13.6W (610R) / MAX: 10.3W (610P)

### Dimensions

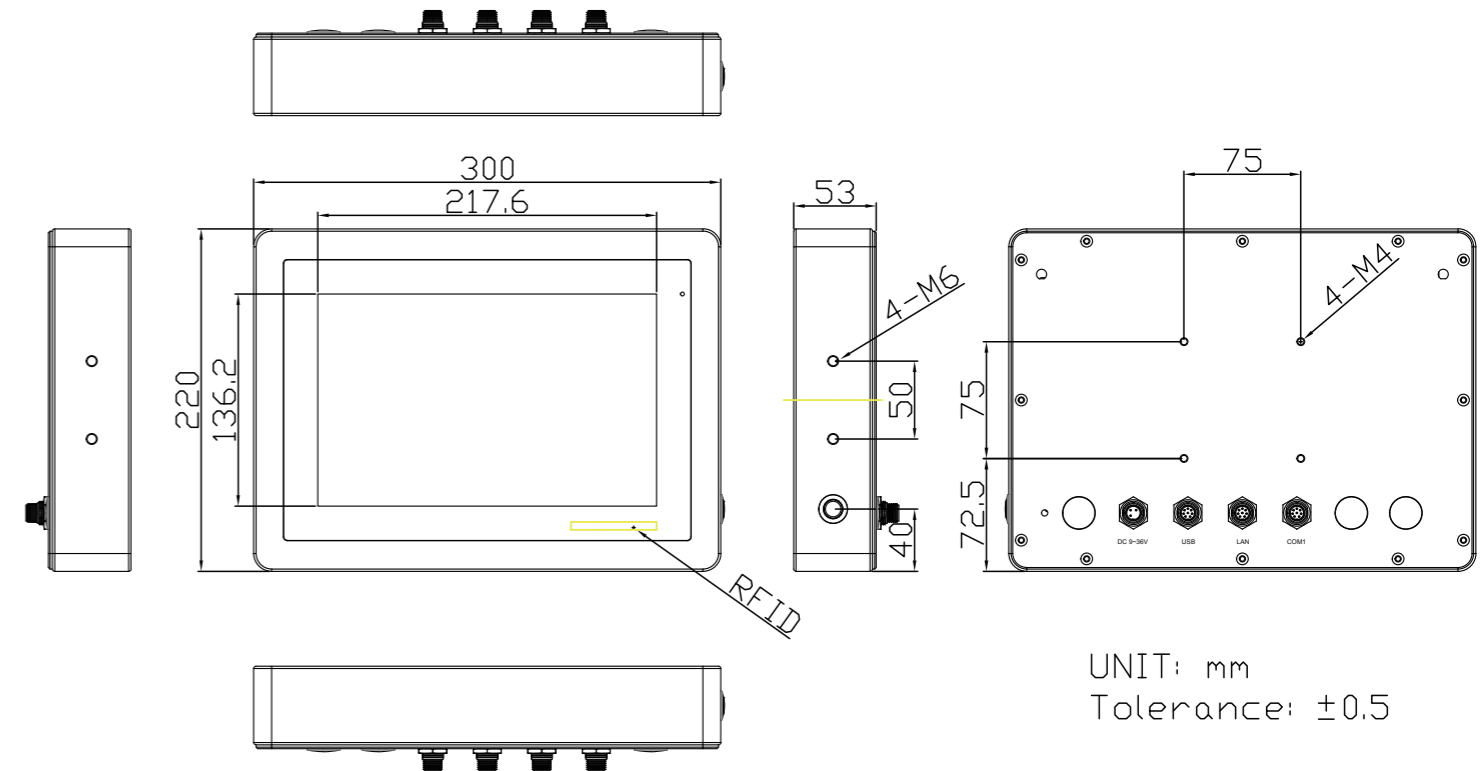

UNIT: mm  
Tolerance: ±0.5

Mechanical	
Color	304 Stainless Steel Enclosure (Default) 316 Stainless Steel Enclosure (Optional)
Construction	Stainless steel enclosure
Mounting	VESA mount 75 x 75, Yoke mount
IP Rating	IP66/IP69K
Dimension	300 x 220 x 53 mm
Net Weight	3.8 Kg

Environmental	
Operating temperature(°C)	-20~60°C
Storage temperature(°C)	-30°C~70°C
Storage humidity	10 to 90% @ 40°C, non-condensing
Certification	CE/FCC class A

Operating System Support	
Linux 3.2, Android 4.2.2	

Ordering information	
ViTAM-610P-01	10.1"/1280x800/S.S./IMX6/1G/4GeMMC/PCT/9~36V/w ADP/ANDROID
ViTAM-610R-01	10.1"/1280x800/S.S./IMX6/1G/4GeMMC/RT/9~36V/w ADP/ANDROID
ViTAM-610G-01	10.1"/1280x800/S.S./IMX6/1G/4GeMMC/GLASS/9~36V/w ADP/ANDROID
ViTAM-610PH-01	10.1"/1280x800/1000NITS/S.S./IMX6/1G/4GeMMC/PCT/9~36V/w ADP/ANDROID
ViTAM-610RH-01	10.1"/1280x800/1000NITS/S.S./IMX6/1G/4GeMMC/RT/9~36V/w ADP/ANDROID
ViTAM-610GH-01	10.1"/1280x800/1000NITS/S.S./IMX6/1G/4GeMMC/GLASS/9~36V/w ADP/ANDROID

## The Netherlands



Elektrostraat 17  
NL-7483 PG Haaksbergen

T: +31 (0)53 573 33 33  
F: +31 (0)53 573 33 30  
E: [nl@texim-europe.com](mailto:nl@texim-europe.com)

## Belgium



Zuiderlaan 14 bus 10  
B-1731 Zellik

T: +32 (0)2 462 01 00  
F: +32 (0)2 462 01 25  
E: [belgium@texim-europe.com](mailto:belgium@texim-europe.com)

## UK & Ireland



St. Mary's House, Church Lane  
Carlton Le Moorland  
Lincoln LN5 9HS

T: +44 (0)1522 789 555  
F: +44 (0)845 299 22 26  
E: [uk@texim-europe.com](mailto:uk@texim-europe.com)

## Germany North



Bahnhofstrasse 92  
D-25451 Quickborn

T: +49 (0)4106 627 07-0  
F: +49 (0)4106 627 07-20  
E: [germany@texim-europe.com](mailto:germany@texim-europe.com)

## Germany South



Martin-Kollar-Strasse 9  
D-81829 München

T: +49 (0)89 436 086-0  
F: +49 (0)89 436 086-19  
E: [germany@texim-europe.com](mailto:germany@texim-europe.com)

## Austria



Warwitzstrasse 9  
A-5020 Salzburg

T: +43 (0)662 216 026  
F: +43 (0)662 216 026-66  
E: [austria@texim-europe.com](mailto:austria@texim-europe.com)

## Nordic region



Sdr. Jagtvej 12  
DK-2970 Hørsholm

T: +45 88 20 26 30  
F: +45 88 20 26 39  
E: [nordic@texim-europe.com](mailto:nordic@texim-europe.com)

## General information



[info@texim-europe.com](mailto:info@texim-europe.com)  
[www.texim-europe.com](http://www.texim-europe.com)