



LS25-150 Series

Single Output General Purpose Power Supplies

- High MTBF up to 900 000 hours
- Superior operating temperature performance up to 70°C
- Very High efficiency up to 87%
- Very Low Cost
- Compact
- Withstands 300VAC surges (5s)
- Five Year Warranty

Key Market Segments & Applications

- Test & Measurement
- Automated Service
- Factory Automation
- General Purpose
- LED Lighting & Display

LS25-150 Features and Benefits

Features

- High MTBF
- High efficiency
- -25 to +70°C operating temperature
- Low derating above 50 °C (up to 70% load available at 70° C)
- Curve B EMC

Benefits

- Superior Reliability
- Easier system cooling
- Suitable for indoor & outdoor enclosures
- Improved system power optimisation
- Assists system compliance

Specifications

ITEMS		LS25	LS35	LS50	LS75	LS100	LS150	
AC Input Voltage (300VAC for 5s)	VAC	88 - 264VAC (See note (2) for LS100)					88-132/176-264VAC(1)	
Input Frequency	Hz	47 - 63Hz						
DC Input Voltage	VDC	125 - 373VDC				248 - 273VDC		
Inrush Current (230VAC, cold start)	A	30	40	40	40	60	40	
Power Factor	-	Meets EN61000-3-2, -3						
Input Current (115/230VAC)	A	0.7 / 0.4	0.8 / 0.55	1.3 / 0.8	1.6 / 1.0	2.2 / 1.2	3.5 / 2	
Temperature Coefficient	-	<0.02%/°C (0 - 50°C)						
Overcurrent Protection	-	> 110%						
Overvoltage Protection	V	3.3V: 3.8-4.45V, 5V: 5.75-6.75V, 12V: 13.8-16.2V, 15V: 17.25-20.25V, 24V: 27.6-32.4V, 36V: 41.4-48.6V, 48V: 55.2-64.8V						
Hold Up Time (115 / 230V input)	ms	14 / 80	12 / 80	14 / 60	14 / 60	25 / 150	20 / 28	
Leakage Current (230VAC 60Hz)	mA	<1mA						
Remote Sense	-	No						
LED Indicator	-	Green LED = On						
Operating Temperature	-	-25 to +70°C. Derate linearly to 50% load from +50 to +70°C (2)						
Storage Temperature	°C	-40 to +85°C						
Operating Humidity	-	20 - 90% RH (non condensing)						
Storage Humidity	-	10 - 95% RH (non condensing)						
Cooling	-	Convection						
Withstand Voltage	-	Input to Ground 1.5kVAC, Input to Output 3kVAC, Output to Ground 500VAC for 1 min.						
Isolation Resistance	-	>100MΩ at 25°C & 70%RH, Output to Ground 500VDC						
Vibration (non operating)	-	10 - 55Hz: 19.6m/s ² constant sweep 1 min X, Y, Z for 1 hour						
Shock	-	< 196.1 m/s ² (20G)						
Immunity	-	IEC61000-4-2, -3, -4, -5, -6, -8, -11						
Safety Agency Approvals	-	UL60950-1, EN60950-1, IEC60950-1, CE Mark						
Conducted & Radiated EMI	-	EN55011/EN55022-B, FCC-B						
MTBF (MIL-HDBK-217F)	hrs	906,997	706,464	712,890	648,786	545,375	505,393	
Weight (Typ)	g	170	270	350	410	600	700	
Size (LxWxH)	mm	79 x 51 x 28	99 x 82 x 36	99 x 97 x 36	130 x 97 x 38	160 x 97 x 38	198 x 99 x 38	
Warranty	yrs	5						

Model Selector							
Model	Voltage	Adjust Range (V)	Max Current (A)	Load Reg (mV)	Line Reg (mV)	Ripple Noise (mV)	Efficiency (typ) %
LS25-3.3	3.3V	2.85 - 3.6	6	66	16.5	80	72
LS25-5	5V	4.5 - 5.5	5	50	25	80	77
LS25-12	12V	10.8 - 13.2	2.1	60	60	120	79
LS25-15	15V	13.5 - 16.5	1.7	75	75	120	82
LS25-24	24V	22 - 27.6	1.1	120	120	120	84
LS25-36	36V	32 - 40	0.75	150	150	150	85
LS25-48	48V	42 - 54	0.57	180	180	200	85
LS35-3.3	3.3V	2.85 - 3.6	7	66	16.5	80	73
LS35-5	5V	4.5 - 5.5	7	50	25	80	77
LS35-12	12V	10.8 - 13.2	3	60	60	120	81
LS35-15	15V	13.5 - 16.5	2.4	75	75	120	83
LS35-24	24V	22 - 27.6	1.5	120	120	120	84
LS35-36	36V	32 - 40	1	150	150	150	84
LS35-48	48V	42 - 54	0.8	180	180	200	84
LS50-3.3	3.3V	3.0 - 3.6	10	40	20	80	75
LS50-5	5V	4.75 - 5.5	10	40	20	80	80
LS50-12	12V	10.8 - 13.2	4.2	96	48	120	84
LS50-15	15V	13.5 - 16.5	3.4	120	60	120	85
LS50-24	24V	22 - 27.2	2.2	192	96	120	86
LS50-36	36V	32 - 40	1.4	288	144	150	86
LS50-48	48V	42 - 54	1.1	384	192	200	86
LS75-3.3	3.3V	3.0 - 3.6	15	40	20	80	75
LS75-5	5V	4.75 - 5.5	12	40	20	80	79
LS75-12	12V	10.8 - 13.2	6	96	48	120	84
LS75-15	15V	13.5 - 16.5	5	120	60	120	85
LS75-24	24V	22 - 27.2	3.2	192	96	120	86
LS75-36	36V	32 - 40	2.1	288	144	150	86
LS75-48	48V	42 - 54	1.6	384	192	200	87
LS100-3.3	3.3V	3.0 - 3.6	20	66	16.5	80	74
LS100-5	5V	4.75 - 5.5	16	50	25	80	77
LS100-12	12V	10.8 - 13.2	8.5	60	60	120	81
LS100-15	15V	13.5 - 16.5	7	75	75	120	82
LS100-24	24V	22 - 27.2	4.5	120	120	120	84
LS100-36	36V	32 - 40	3	150	150	150	84
LS100-48	48V	42 - 54	2.3	180	180	200	84
LS150-3.3	3.3V	3.0 - 3.6	30	66	16.5	80	74
LS150-5	5V	4.75 - 5.5	26	50	25	80	78
LS150-12	12V	10.8 - 13.2	12.5	60	60	120	83
LS150-15	15V	13.5 - 16.5	10	75	75	120	84
LS150-24	24V	22 - 27.2	6.5	120	120	120	86
LS150-36	36V	32 - 40	4.3	150	150	150	86
LS150-48	48V	42 - 54	3.3	180	180	200	87

Notes: See page 1

- (1) Switch selectable for 115 or 230VAC
- (2) LS50, LS75-3.3 & -5: Derate linearly to 70% load from +50 to +70°C.
 LS75-12,-15,-24,-36,-48 Derate linearly to 60% load from +50 to +70°C.
 LS100-3.3 & 5 Derate linearly to 60% load from +45 to +70°C. Derate linearly to 80% load from 115V to 88VAC input.
 LS100-12,-15,-24,-36,-48 Derate linearly to 60% load from +50 to +70°C. Derate linearly to 80% load from 115V to 88VAC input.
 LS150-3.3 & 5 Derate linearly to 50% load from +40 to +70°C.
 LS150-12,-15,-24,-36,-48 Derate linearly to 70% load from +50 to +70°C.

Outline Drawing LS25

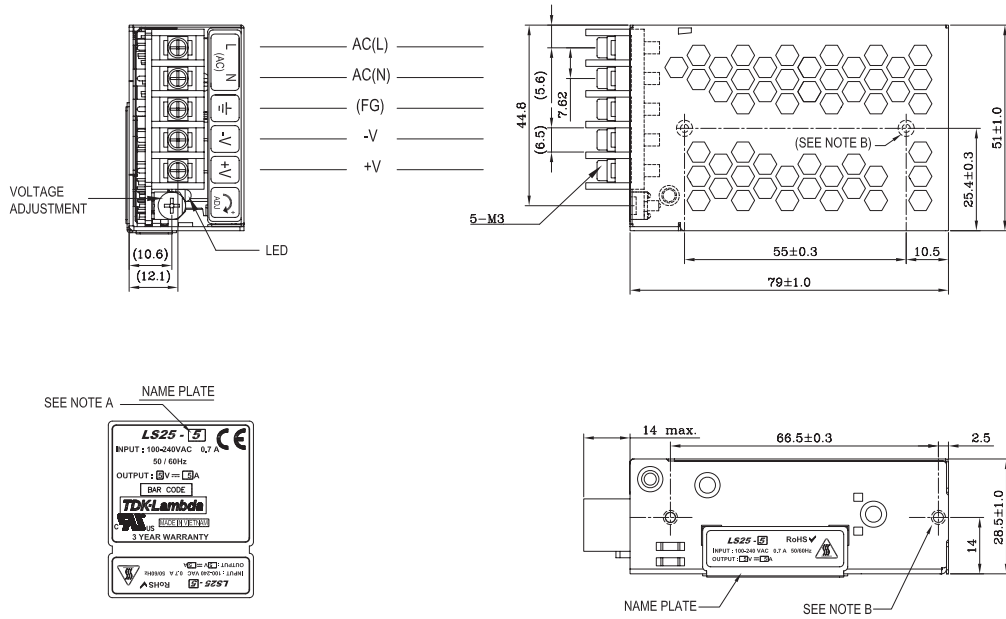

NOTES

- A. MODEL NAME , INPUT VOLTAGE RANGE , NOMINAL OUTPUT VOLTAGE , MAXIMUM OUTPUT CURRENT & COUNTRY OF MANUFACTURE ARE SHOWN IN ACCORDANCE WITH THE SPECIFICATION.
- B. M3 TAPPED , EMBOSSED & COUNTERSUNK HOLES (4) FOR CUSTOMER CHASSIS MOUNTING. SCREWS MUST NOT PROTRUDE INTO POWER SUPPLY BY MORE THAN 4mm.
- C. UNLESS OTHERWISE SPECIFIED, DIMENSION TOLERANCE = ±0.3mm.

Outline Drawing LS35

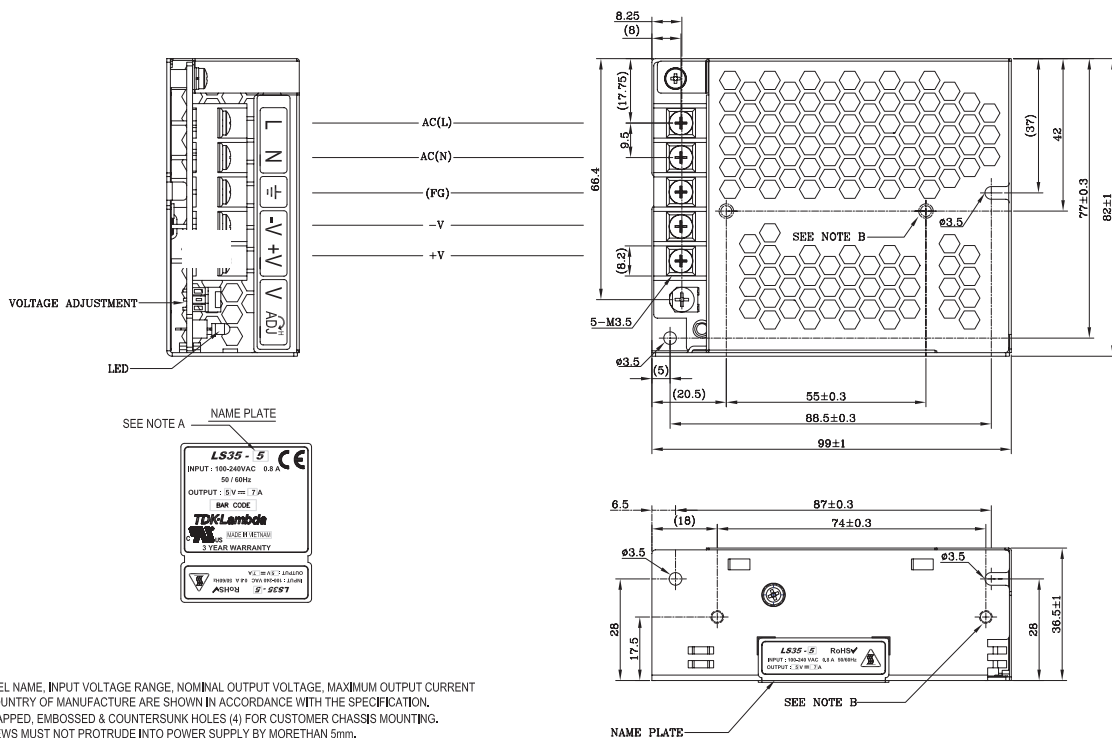

NOTES

- A. MODEL NAME , INPUT VOLTAGE RANGE , NOMINAL OUTPUT VOLTAGE , MAXIMUM OUTPUT CURRENT & COUNTRY OF MANUFACTURE ARE SHOWN IN ACCORDANCE WITH THE SPECIFICATION.
- B. M3 TAPPED , EMBOSSED & COUNTERSUNK HOLES (4) FOR CUSTOMER CHASSIS MOUNTING. SCREWS MUST NOT PROTRUDE INTO POWER SUPPLY BY MORE THAN 5mm.
- C. UNLESS OTHERWISE SPECIFIED, DIMENSION TOLERANCE = ±0.3mm.

Outline Drawing LS50

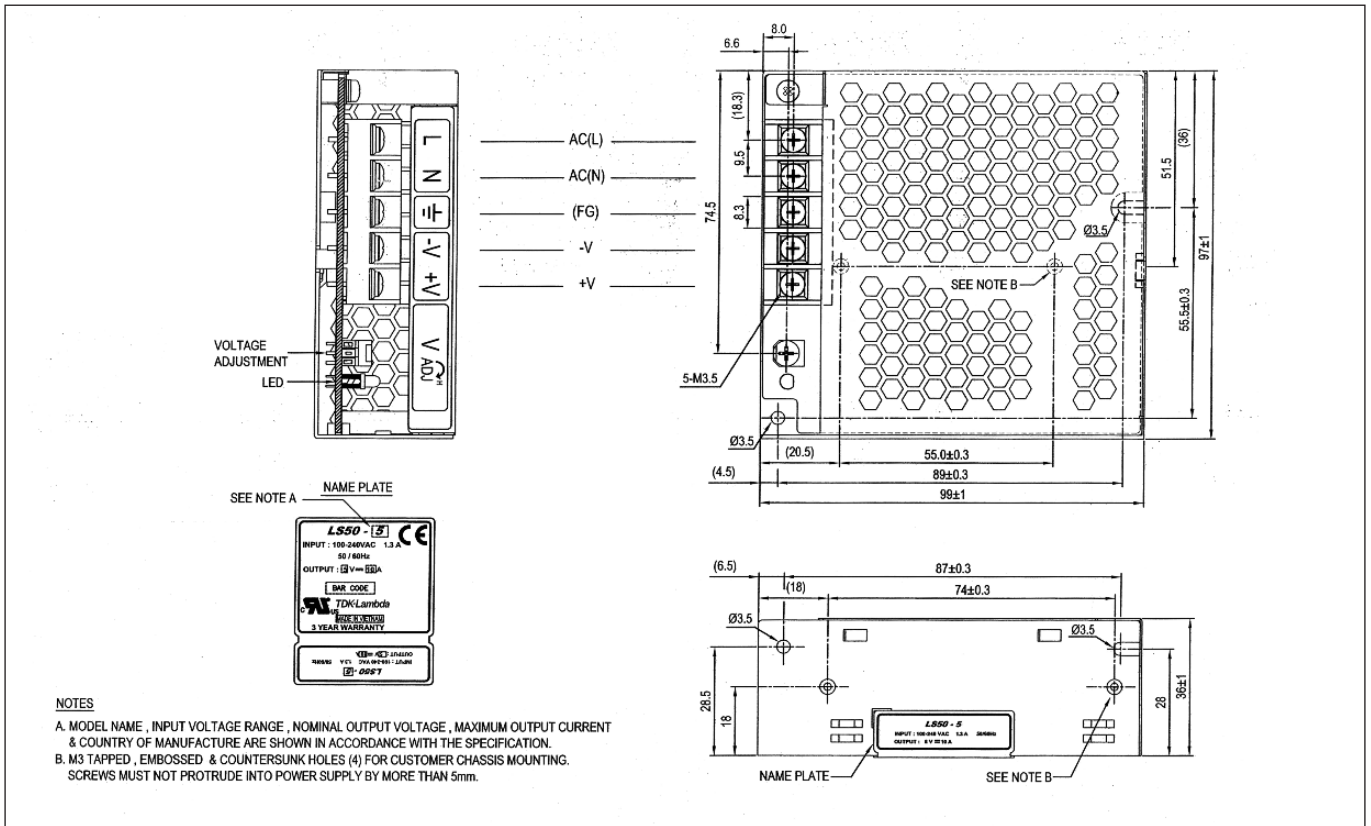

Outline Drawing LS75

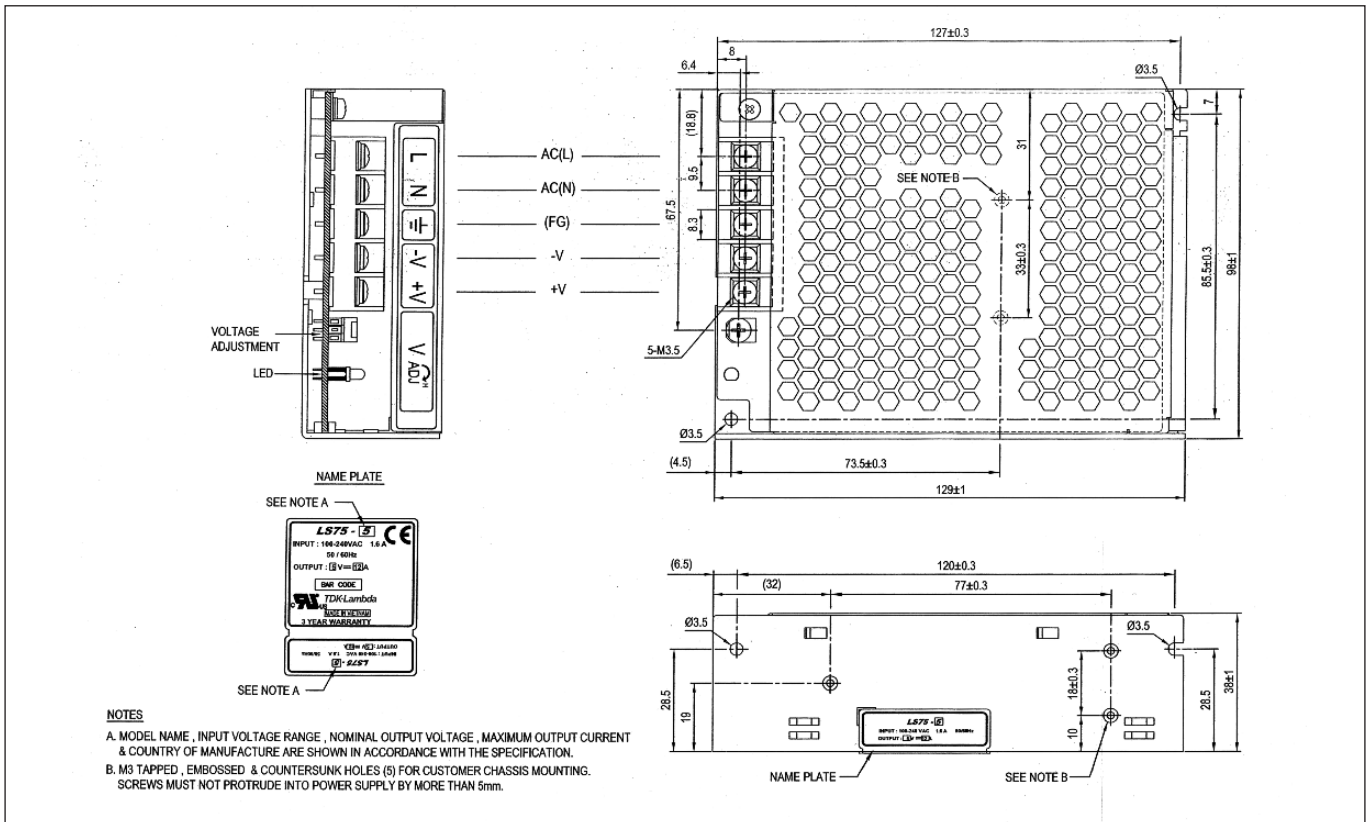

Outline Drawing LS100

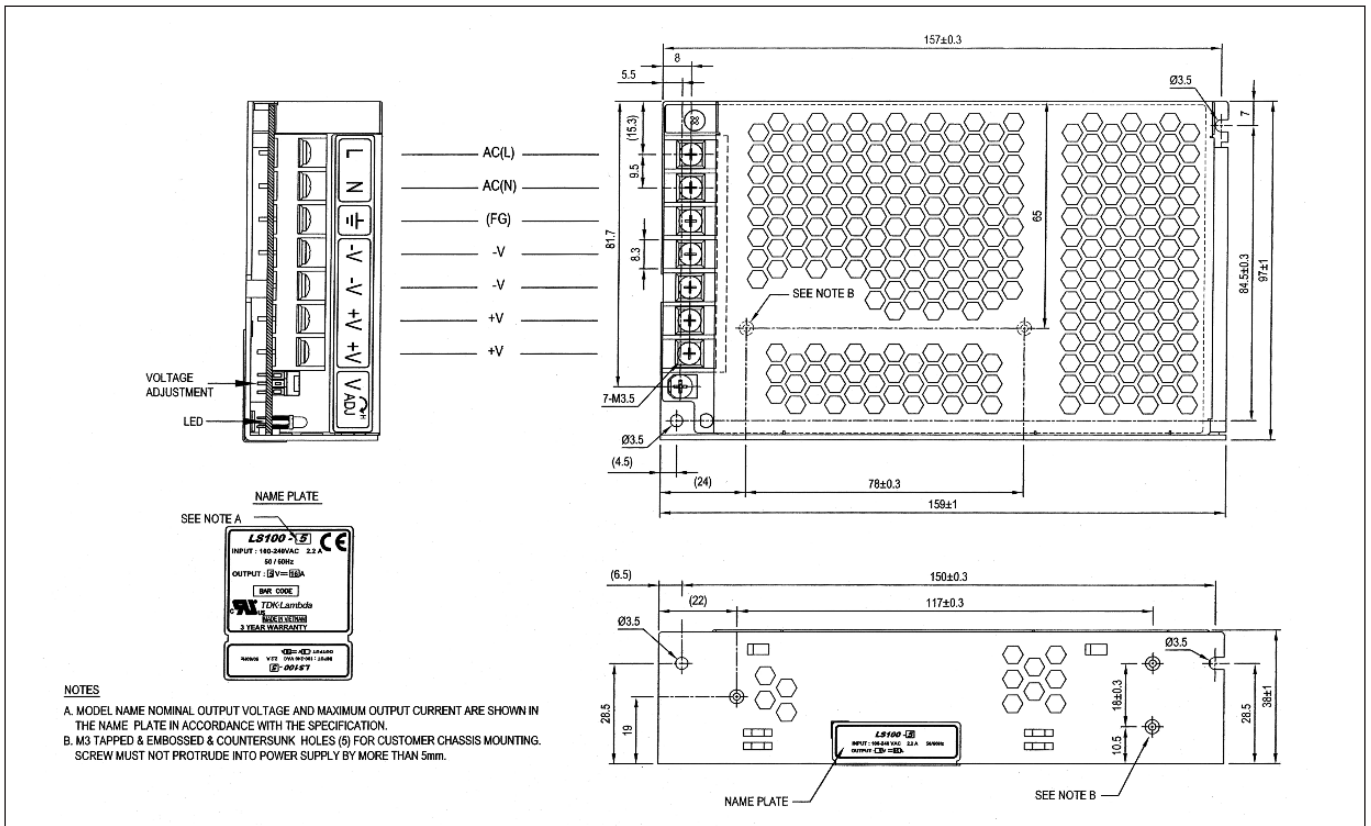

Outline Drawing LS150

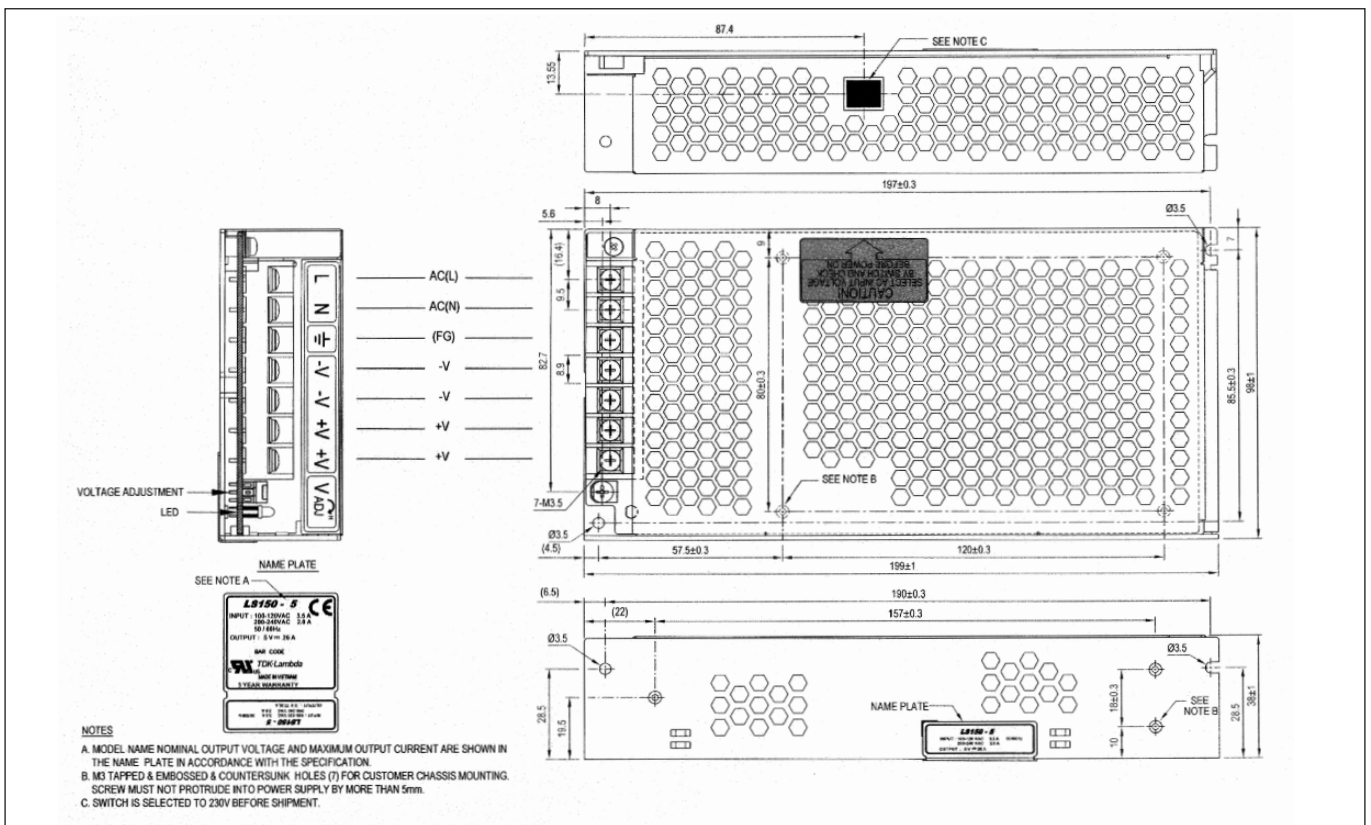

The Netherlands



Elektrostraat 17
NL-7483 PG Haaksbergen

T: +31 (0)53 573 33 33
F: +31 (0)53 573 33 30
E: nl@texim-europe.com

Belgium



Zuiderlaan 14 bus 10
B-1731 Zellik

T: +32 (0)2 462 01 00
F: +32 (0)2 462 01 25
E: belgium@texim-europe.com

UK & Ireland



St. Mary's House, Church Lane
Carlton Le Moorland
Lincoln LN5 9HS

T: +44 (0)1522 789 555
F: +44 (0)845 299 22 26
E: uk@texim-europe.com

Germany North



Bahnhofstrasse 92
D-25451 Quickborn

T: +49 (0)4106 627 07-0
F: +49 (0)4106 627 07-20
E: germany@texim-europe.com

Germany South



Martin-Kollar-Strasse 9
D-81829 München

T: +49 (0)89 436 086-0
F: +49 (0)89 436 086-19
E: germany@texim-europe.com

Austria



Warwitzstrasse 9
A-5020 Salzburg

T: +43 (0)662 216 026
F: +43 (0)662 216 026-66
E: austria@texim-europe.com

Nordic region



Sdr. Jagtvej 12
DK-2970 Hørsholm

T: +45 88 20 26 30
F: +45 88 20 26 39
E: nordic@texim-europe.com

General information



info@texim-europe.com
www.texim-europe.com