

Distributed by:



[www.texim-europe.com](http://www.texim-europe.com)

# LoRaWAN TEMP

## Ready-To-Use Temperature Device

Guide utilisateur / User Guide

Version 2.0.0

**Ce Guide utilisateur s'applique à partir des versions logicielles suivantes :**  
**This User Guide applies from the following firmware versions:**

**Version RTU : V01.04.00**

**Version APP : V01.03.03**

adeunis ®

283 rue Louis Néel - Parc Technologique Pré Roux

38920 CROLLES - France

DISTRIBUTED BY TEXIM EUROPE - Tel : +33 (0)4 76 04 80 87

[www.adeunis.com](http://www.adeunis.com) [sales@adeunis.com](mailto:sales@adeunis.com)



## PRODUCTS AND REGULATORY INFORMATION

Document Information	
<b>Title</b>	LoRaWAN TEMP - User Guide
<b>Sub-title</b>	/
<b>Document type</b>	User Guide
<b>Version</b>	2.0.0

This document applies to the following products :

Nom	Référence	Version firmware
<b>LoRaWAN TEMP 868</b>	ARF8180BA	RTU version: V01.04.00 APP version:V01.03.03

EN

## DISCLAIMER

This document and the use of any information contained therein, is subject to the acceptance of the adeunis® terms and conditions. They can be downloaded from [www.adeunis.com](http://www.adeunis.com).

adeunis® makes no warranties based on the accuracy or completeness of the contents of this document and reserves the right to make changes to specifications and product descriptions at any time without notice.

adeunis® reserves all rights to this document and the information contained herein. Reproduction, use or disclosure to third parties without express permission is strictly prohibited. Copyright © 2016, adeunis®.

adeunis® is a registered trademark in the EU and other countries.

## TECHNICAL SUPPORT

### Website

Our website contains a lot of useful information: information on modules and wireless modems, user guides, and configuration software and technical documents which can be accessed 24 hours a day.

### E-mail

If you have technical problems or cannot find the required information in the provided documents, contact our Technical Support by e-mail. Use our dedicated e-mail address ([arf@adeunis.com](mailto:arf@adeunis.com)) rather than any personal e-mail address of our staff. This ensures that your request will be processed as soon as possible.

Helpful Information when Contacting Technical Support

When contacting Technical Support, please have the following information ready:

- Product type
- Firmware version (for example V1.0)
- A clear description of your question or the problem
- A short description of the application

## EU Declaration of Conformity

### WE

adeunis  
 283 rue LOUIS NEEL  
 38920 Crolles, France  
 04.76.92.01.62  
 www.adeunis.com

**Declare that the DoC is issued under our sole responsibility and belongs to the following product:**

Apparatus model/Product: TEMP LoRaWAN  
 Type: ARF8180AA, ARF8180BA

**Object of the declaration:**

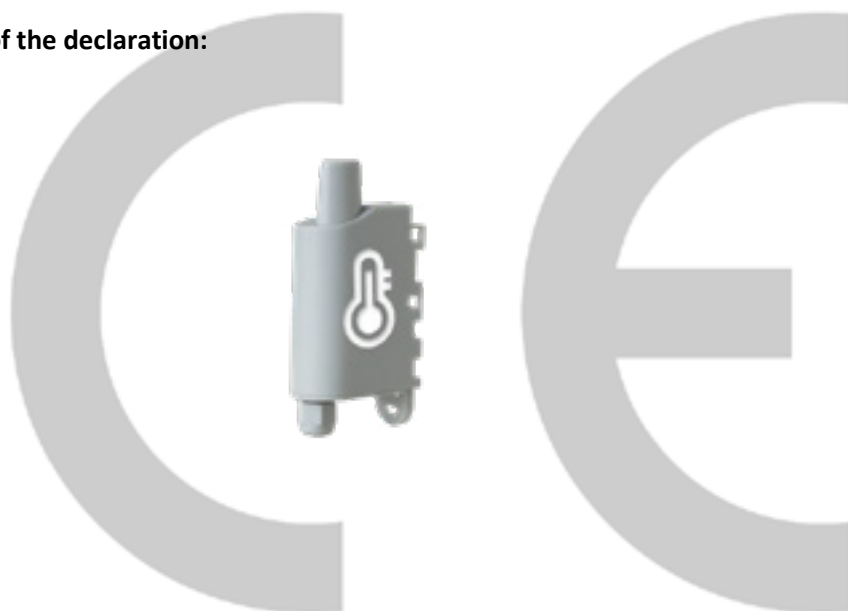

The object of the declaration described above is in conformity with the relevant Union harmonisation legislation:

**Directive 2014/53/UE (RED)**

**The following harmonised standards and technical specifications have been applied:**

Title:	Date of standard/specification
EN 300 220-2 V3.1.1	2017/02
EN 301 489-1 V2.1.1	2016/11
EN 301 489-3 V2.1.0	2016/09
EN 62368-1	2014
EN 62311	2008

October, 5<sup>th</sup>, 2017

Monnet Emmanuel, Certification Manager



## INTRODUCTION

All rights to this manual are the exclusive property of adeunis®. All rights reserved. Copying this manual (without written permission from the owner) via printing, copying, recording or by any other means, translating this manual (in full or partially) into any other language, including all programming languages, using any electrical, mechanical, magnetic or optical devices, manually or any by other methods, is prohibited.

adeunis® reserves the right to change the technical specifications or functions of its products, or to cease manufacturing any of its products, or to cease technical support for one of its products without notice in writing and urges its customers to make sure that the information they have is valid.

adeunis® configuration software and programs are available free of charge in a non-modifiable version. adeunis® can make no guarantees, including guarantees concerning suitability and applicability for a certain type of application. Under no circumstances can the manufacturer, or the distributor of an adeunis® program, be held liable for any damage caused by the use of the aforesaid program. Program names, as well as all copyright relating to programs, are the exclusive property of adeunis®. Any transfer, granting of licences to a third party, leasing, hire, transport, copying, editing, translation, modification into another programming language or reverse engineering are prohibited without adeunis®'s prior written authorisation and consent.

### **Adeunis**

283, rue Louis Néel  
38920 Crolles  
France

Téléphone +33 (0)4 76 92 07 77  
Fax +33 (0)4 76 04 80 87

**EN**

## ENVIRONMENTAL RECOMMENDATIONS

All superfluous packaging materials have been eliminated. We have done everything possible to make it easy to separate the packaging into three types of materials: cardboard (box), expanded polystyrene (filler material) and polyethylene (packets, foam protective sheets). Your device is composed of materials that can be recycled and reused if it is dismantled by a specialist company. Please observe local regulations concerning the manner in which waste packaging material, used batteries and your obsolete equipment are disposed of.

## WARNINGS

Valid for products indicated in the declaration of conformity



Read the instructions in the manual.

The safety of this product is only guaranteed when it is used in accordance with its purpose. Maintenance should only be carried out by qualified persons.

**Please note:** Do not install the equipment close to a heat source or in damp conditions.

**Please note:** When the equipment is open, do not carry out any operations other than the ones set out in this document.



Please note: Do not open the product as there is a risk of electrical shock.



Please note: For your own safety, you must ensure that the equipment is switched off before carrying out any work on it.



Please note: For your own safety, the power supply circuit must be SELV (Safety Extra Low Voltage) and must be from limited power sources.



Please note: When the aerial is installed outside, it is essential to connect the cable screen to the building's earth. We recommend using lightning protection. The protection kit chosen must permit the coaxial cable to be earthed (eg: coaxial lightning arrester with earthing of the cable at different places on the aerial at the base of pylons and at the entrance, or just before entering the premises).

The product must be equipped with a switching mechanism so that the power can be cut. This must be close to the equipment. Any electrical connection of the product must be equipped with a protection device against voltage spikes and short-circuits.

## RECOMMENDATIONS REGARDING USE

- Before using the system, check that the power supply voltage shown in the user manual corresponds to your supply. If it doesn't, please consult your supplier.
- Place the device against a flat, firm and stable surface.
- The device must be installed in a location that is sufficiently ventilated so that there is no risk of internal heating and it must not be covered with objects such as newspapers, cloths, curtains, etc.
- The device's aerial must be free and at least 10 cm away from any conducting material.
- The device must never be exposed to heat sources such as heating equipment.
- Do not place the device close to objects with naked flames such as lit candles, blowtorches, etc.
- The device must not be exposed to harsh chemical agents or solvents likely to damage the plastic or corrode the metal parts.

## DISPOSAL OF WASTE BY USERS IN PRIVATE HOUSEHOLDS WITHIN THE EUROPEAN UNION



This symbol on the product or on its packaging indicates that this product must not be disposed of with your other household waste. Instead, it is your responsibility to dispose of your waste by taking it to a collection point designated for the recycling of electrical and electronic appliances. Separate collection and recycling of your waste at the time of disposal will contribute to conserving natural resources and guarantee recycling that respects the environment and human health. For further information concerning your nearest recycling centre, please contact your nearest local authority/town hall offices, your household waste collection company or the shop where you bought the product



This symbol on the device or its packaging means the use of a DC voltage.



Warning: If the charger is used with any other batteries or products whatsoever, there is a risk of an explosion. After use, the batteries must be disposed of at an appropriate recycling centre. They must not be thrown away to degrade in the environment. When batteries are replaced, the device must be correctly implemented.



Warning for Switzerland : the annex 4.10 of SR 814.013 Standard must be applied for batteries.

## 1. PRODUCT PRESENTATION

**NOTE IMPORTANTE :** The LoRaWAN TEMP can only be started with a magnet.

Description:

- The adeunis® LoRaWAN TEMP is a ready-to-use radio device enabling temperatures to be measured and transmitted by wireless communication network.
- This product meets the needs of users who require to remotely monitor internal and external temperatures of storage rooms, meeting rooms, cold rooms, etc.
- The use of the LoRaWAN protocol allows the user to integrate the LoRaWAN TEMP into any network that is already deployed.
- The LoRaWAN TEMP is fitted with internal and external probes.
- The product emits the data from the sensors either periodically or in an event-based way based on top or bottom thresholds.
- The configuration of the transmitter is accessible by the user via a micro-USB port, allowing in particular a choice of modes of transmission, periodicity or triggering thresholds.
- The LoRaWAN TEMP is powered by a replaceable internal battery.

**IMPORTANT NOTE 1:** The LoRaWAN TEMP is delivered by default with OTAA configuration, allowing the user to declare his/her product to a LoRaWAN operator. For an ABP procedure, please contact our Sales Department with the necessary information.

Composition of the package

The product is supplied in a cardboard box containing the following items:  
top casing, electronic card, casing base plate  
cable gland, 3 gland seals, 2 CBLZ 2.2 x 19mm screws, 2 Fischer SX4 plugs

### 1.1. General description

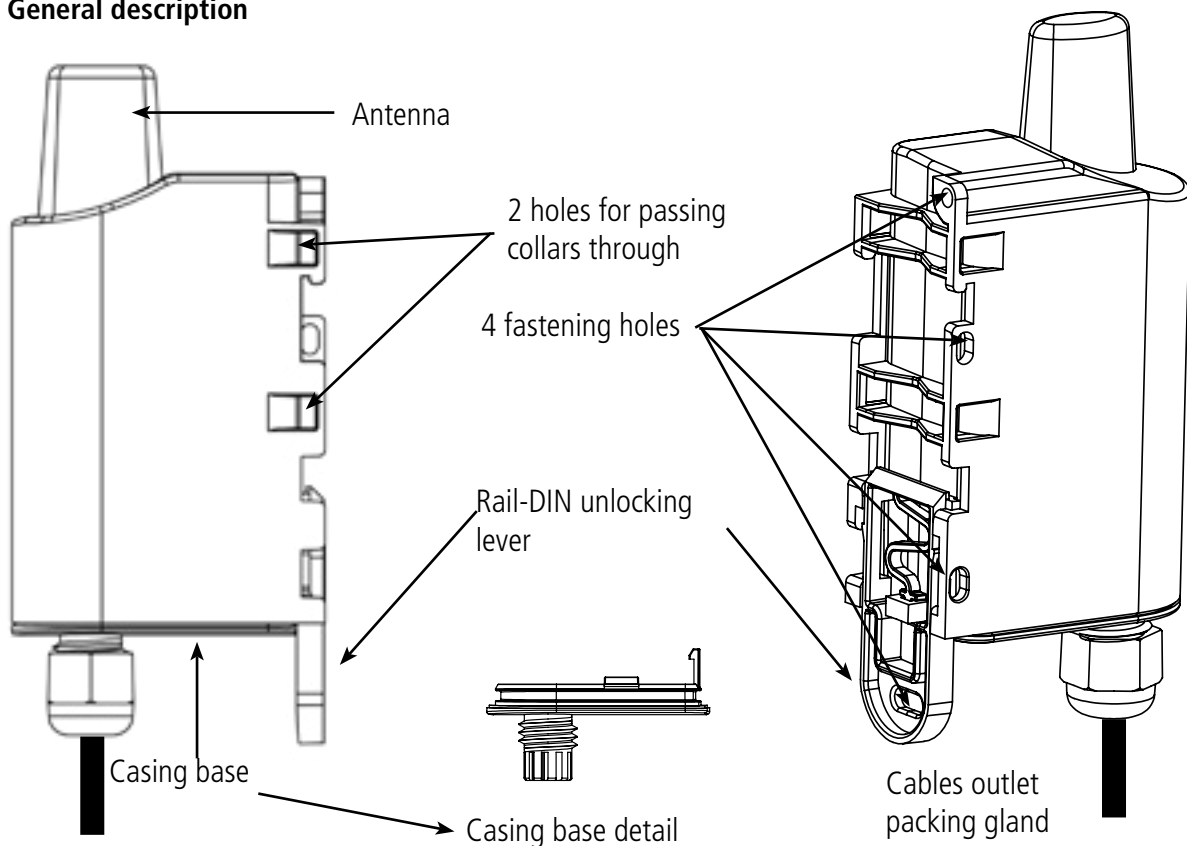

### 1.2. Dimensions

Values in millimetres

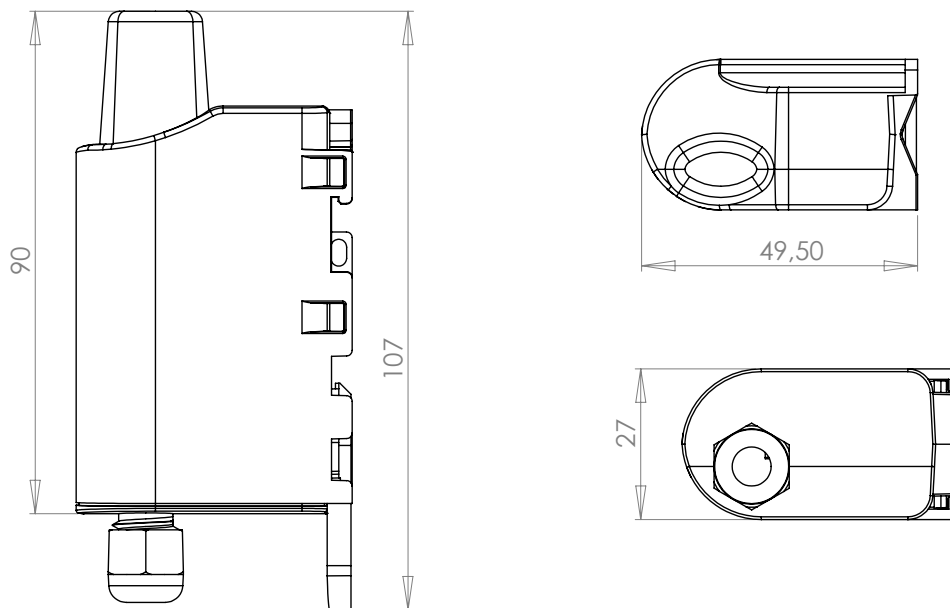

### 1.3. Electronic board

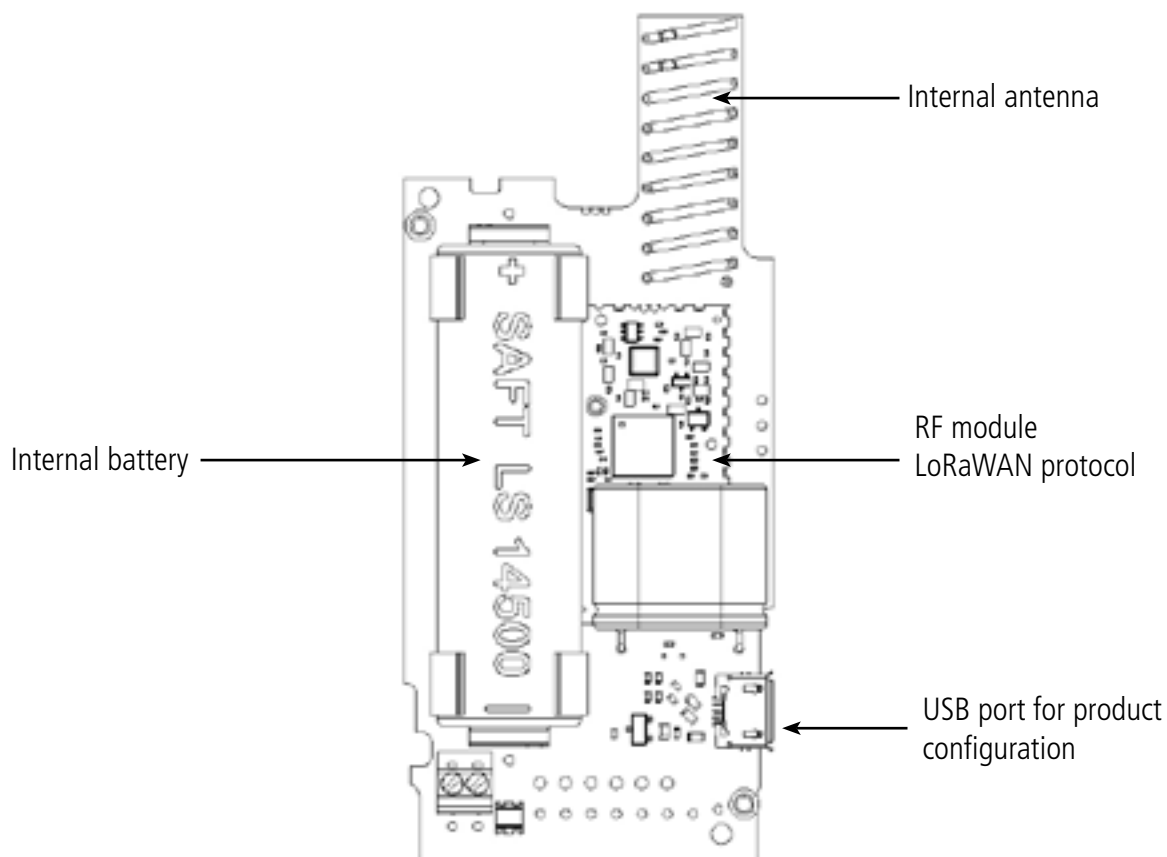

EN



## 1.4. Technical Specifications

### 1.4.1 General characteristics

Parameters	Value
Supply voltage	Nominal 3.6V
Power supply	Removable battery version: SAFT LS14500
Maximal power	90mA
Working temperature	-25°C / +70°C
Dimensions:	105 x 50 x 27mm
Weight	130g
Casing	IP 67
Radio standards	EN 300-220, EN 301-489, EN 60950

### 1.4.2 Autonomy

Operating conditions:	Sending periodicity	Autonomy SF7	Autonomy SF12
Product shelf life before use: Maximum 1 year.	140 frame/day	6.5 years	7 month
	100 frame/day	7.8 years	1 year
Calculations performed at a temperature of 20°C	50 frame/day	10.4 month	1.9 years
	20 frame/day	13 years	4.1 years
	10 frame/day	14.3 years	6.5 years
Without super-sampling factor in the period	2 frame/day	15.4 years	12.2 years

The above values are estimations based on certain conditions of use and environment. They do not represent a commitment on the part of adeunis®.

### 1.4.3 Sensor characteristics

Characteristics	
Internal sensor - temperature range	-30°C .. +70°C
Internal sensor - Inertia by 10°C steps	90 minutes
External sensor - temperature range	-55°C..+155°C
External sensor - Inertia by 10°C steps	15 minutes
External sensor - Cable length	2 meters
Resolution	0,1°C
Precision	+/- 0,1°C

## 2. PRODUCT OPERATION

### 2.1. Global operation

**Important:** adeunis® use the most significant byte first format.

The product has several operating modes:

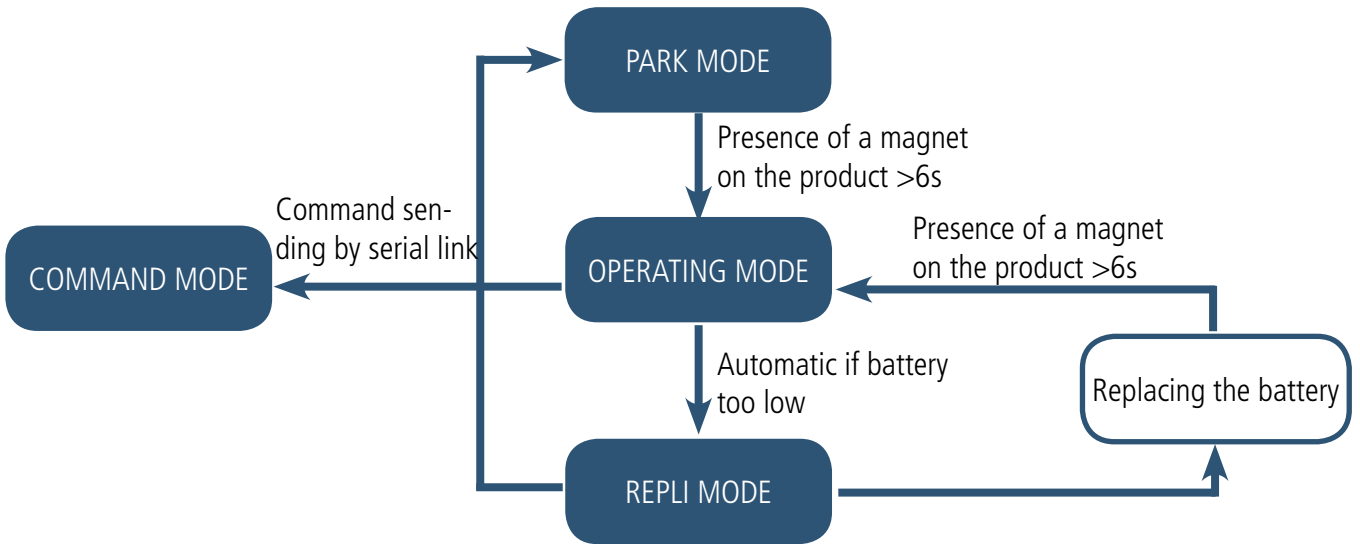

#### 2.1.1 PARK MODE

The product is delivered in PARK mode, it is in standby mode and its consumption is minimal. To switch the product out of the Park\* Mode pass a magnet across it for a duration higher than 6 seconds. The green LED illuminates to indicate the detection of the magnet and then flashes quickly during the product starting phase.

The device then sends its configuration and data frames (see paragraph 4.1).

#### 2.1.2 COMMAND MODE

This mode allows the user to configure the registers of the product.

To enter this mode, connect a cable to the micro-USB port of the product and enter the command mode by an AT command (see paragraph 3).

#### 2.1.3 OPERATING MODE

There are two possible modes of operation:

- TEST mode:  
This mode allows the user to perform tests of the product more quickly by reducing the time scales of production mode and modifying the behaviour of the LEDs (see paragraph 2.2.5).

- PRODUCTION mode:  
This mode allows the user to operate the product in its final use. It should allow a maximum of autonomy to the product.

To switch from one mode to the other the user changes the value of a register

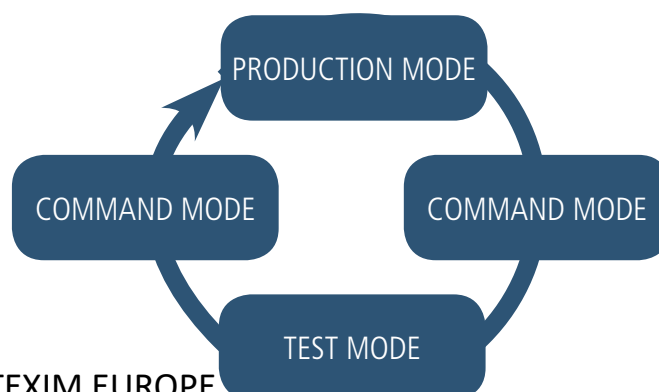

The return to the production mode is done by the ATO command or by disconnecting the USB cable

### 2.1.4 REPLI mode

The product enters this very low consumption mode following the detection of a level of battery that is too low. In this mode the product wakes up every 5 seconds to make the red LED flash twice.

The replacement of the battery (if the product is a replaceable battery version) followed by the application of the magnet takes the product out of this mode to return it to the operating mode.

## 2.2. Operating modes

### 2.2.1 Periodic transmission

The product allows the measurement and the periodic transmission of the values of the sensors according to the following diagram:

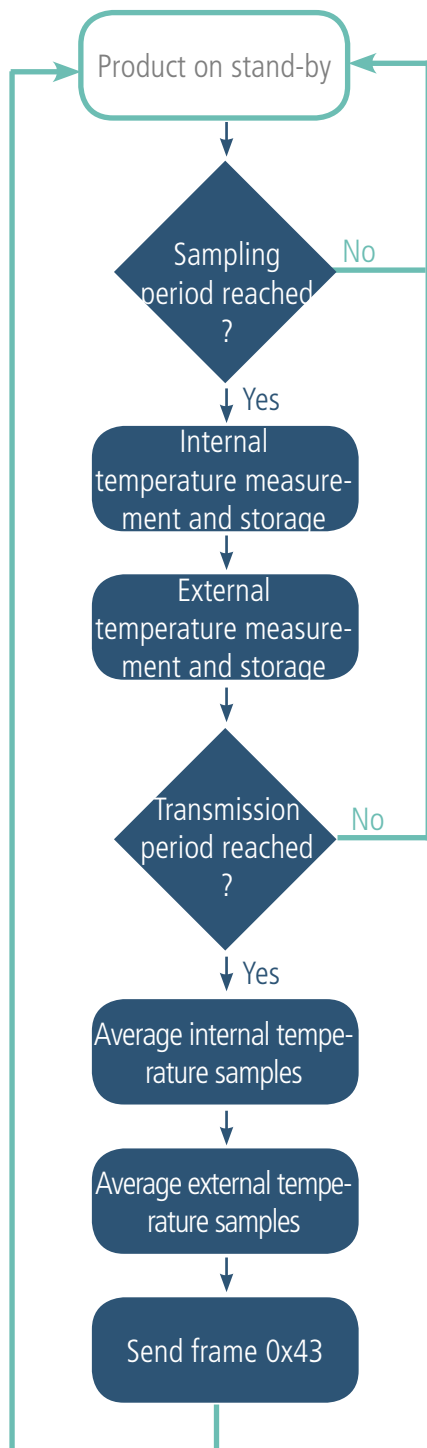

The product allows you to define a super-sampling to send, not an instantaneous value but, an averaged value at the time of the transmission period defined.

The settings associated with this mode of operation are:

- The transmission period (register 301).
- Potential user identifiers for the sensors (registers 320 and 322).
- The super-sampling factor (register 333).

A complete list of the registers can be found in paragraph 3.4.

E.g.:

Register	Value encoding	Value	Result
S301	Decimal	6	Periodic mode with a period of 6x10min = 60 minutes
S320	Hexadecimal	0xD0	Identifier of the internal sensor set to 0xD
S322	Hexadecimal	0x80	Identifier of the external sensor set to 0x8
S333	Decimal	4	The number of samples to be measured and stored between two transmissions is 4

In this example:

- The product transmits every hour (6x10min=60min)
- As the super-sampling factor is 4, there will be a measurement and a storage operation every 60/4=15 minutes
- The value sent will therefore be an average of 4 temperatures collected every 15 minutes

Caution: averaging can reduce the importance of some peaks (maximum values) if the temperature changes quickly.

Take care also over the values of the period and the super-sampling because they have an impact on the consumption of the product. In the extreme a 10 minute transmission periodicity and a factor of super-sampling of 10 leads to a measurement every minute.

### 2.2.2 Transmission over threshold

The product allows the detection threshold overrun (upper and lower) for each sensor according to the following diagram:

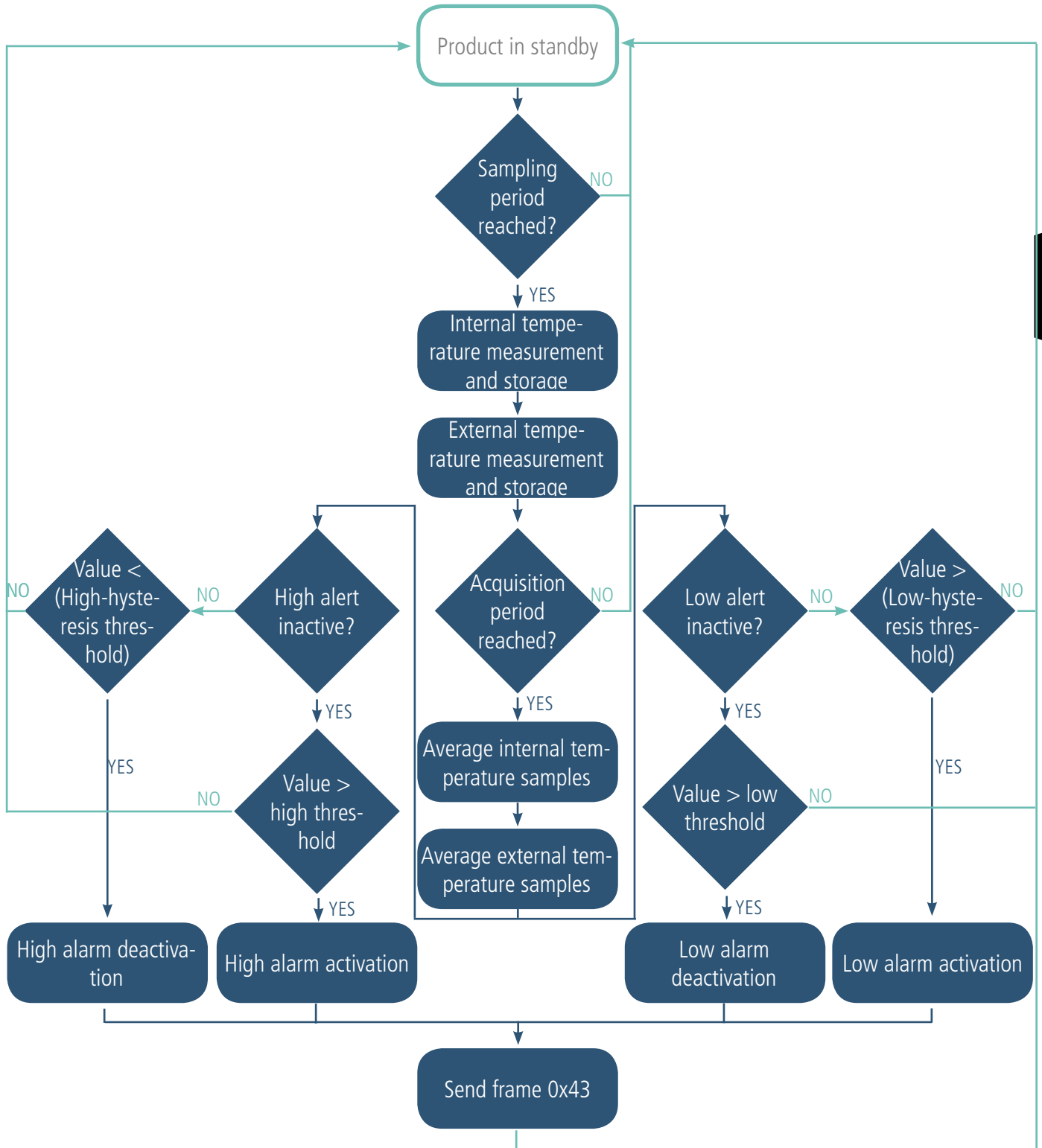

EN

All the beginning of the process follows the same principle as in periodic transmission except that the reference period is the acquisition period instead of the transmission period.

The product sends a frame of data at the threshold overrun and also during a return to normal.

## Explanation of thresholds and hysteresis:

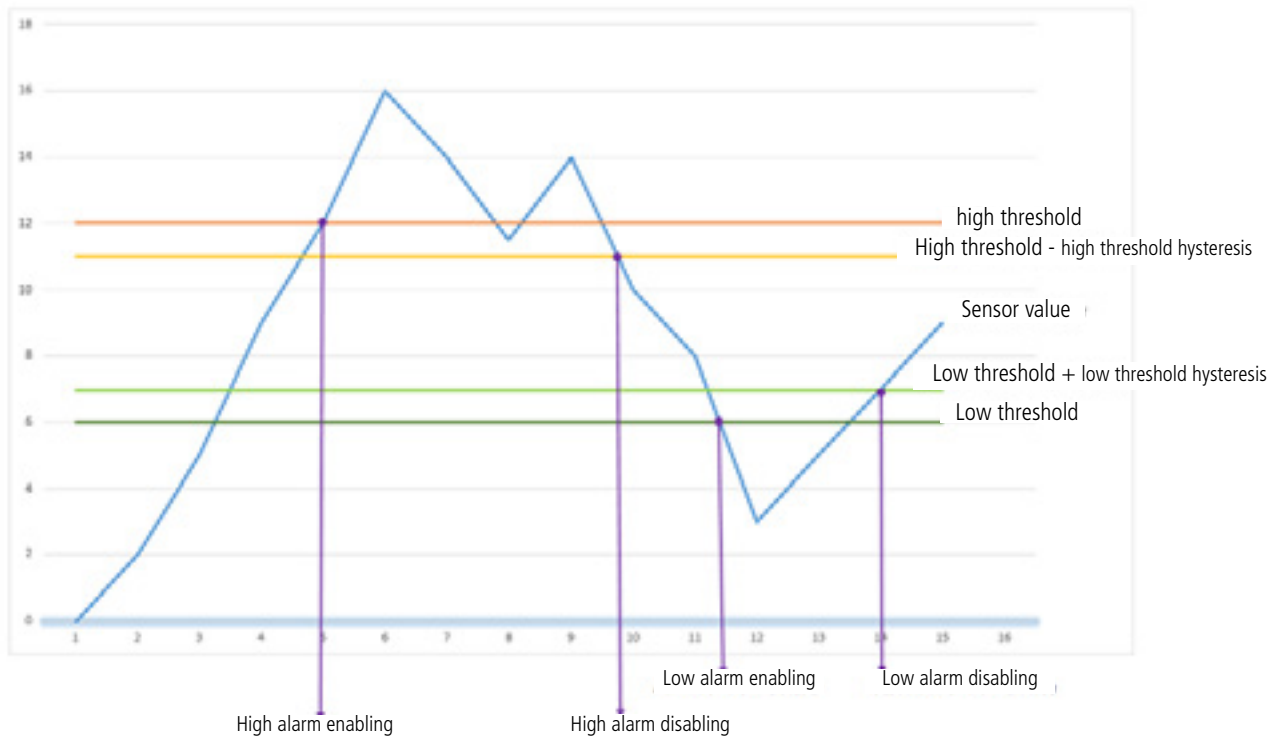

The period of monitoring by the sensors is equal to the period of acquisition (register 332) divided by the super-sampling factor (register 333).

The settings associated with this mode of operation are:

- The transmission periodicity (zero in this usage situation) (register 301)
- Potential user identifiers for the sensors (registers 320 and 322).
- The configuration of the events (registers 321 and 323).
- The high alarm threshold for the internal sensor (register 324).
- The high alarm hysteresis for the internal sensor (register 325).
- The low alarm threshold for the internal sensor (register 326).
- The low alarm hysteresis for the internal sensor (register 327).
- The high alarm threshold for the external sensor (register 328).
- The high alarm hysteresis for the external sensor (register 329).
- The low alarm threshold for the external sensor (register 330).
- The low alarm hysteresis for the external sensor (register 331).
- The acquisition period (register 332).
- The super-sampling factor (register 333).

A complete list of the registers can be found in paragraph 3.4.

E.g.:

Registre	Codage de la valeur	Valeur	Résultat
S301	Décimal	0	Event mode
S320	Hexadécimal	0xD0	Identifier of the internal sensor set to 0xD
S322	Hexadécimal	0x80	Identifier of the external sensor set to 0x8
S321	Hexadécimal	0x03	For the internal sensor: Detection of high and low thresholds
S323	Hexadécimal	0x02	For the external sensor: Detection of high thresholds only
S324	Décimal	300	The value of the high threshold of the internal sensor is: $300/10=30^{\circ}\text{C}$
S325	Décimal	10	The value of the hysteresis of the high threshold of the internal sensor is: $10/10=1^{\circ}\text{C}$
S326	Décimal	50	The value of the low threshold of the internal sensor is: $50/10=5^{\circ}\text{C}$
S327	Décimal	5	The value of the hysteresis of the low threshold of the internal sensor is: $5/10=0.5^{\circ}\text{C}$
S328	Décimal	400	The value of the high threshold of the external sensor is: $400/10=40^{\circ}\text{C}$
S329	Décimal	20	The value of the hysteresis of the high threshold of the external sensor is: $20/10=2^{\circ}\text{C}$
S330	Décimal	-300	The value of the low threshold of the external sensor is: $-300/10=-30^{\circ}\text{C}$
S331	Décimal	10	The value of the hysteresis of the low threshold of the external sensor is: $10/10=1^{\circ}\text{C}$
S332	Décimal	12	The acquisition period is 12 minutes
S333	Décimal	6	The number of samples to be measured and stored between two transmissions is 6

In this example:

- The product compares the measurements every 12 minutes and transmits if necessary
- As the super-sampling factor is 6, there will be a measurement and a storage operation every  $12/6=2$  minutes
- The value sent will therefore be an average of 6 temperatures collected every 2 minutes

Caution: averaging can reduce the importance of some peaks (maximum values) if the temperature changes quickly.

Take care also over the values of the period and the super-sampling because they have an impact on the consumption of the product. In the extreme an acquisition period of 1 minute and a super-sampling factor of 10 produces a measurement every 6 seconds.

### 2.2.3 Transmission of a daily Keep Alive frame

In the event (threshold) mode only, it is possible that the product would never send data frames. So to be sure that it is working properly a Keep Alive frame is transmitted regularly according to the following diagram:

In periodic mode (register 301 different from 0), there is no Keep Alive frame transmission.

The settings associated with this mode of operation are:

- The setting of the period of transmission of the Keep Alive frame (once per hour to once per day) (register 300).

A complete list of the registers can be found in paragraph 3.4.

E.g.:

register	Value encoding	Value	Result
S300	Decimal	72	The Keep Alive frame is sent every: $72 \times 10 = 720 \text{min}$ i.e. 12h (or twice per day)

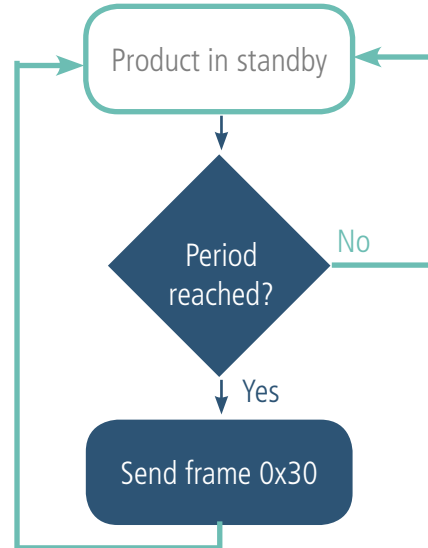

### 2.2.4 TEST mode

This mode allows the user to perform tests of the product more quickly by reducing the time scales of the production mode and modifying the behaviour of the LEDs.

It is obtained by positioning register S306 at the value 2 in the COMMAND mode. Once out of the command mode, the product returns to the previously defined application behaviour but with the following changes:

- register S300: the periodicity of the Keep Alive is expressed in groups of twenty seconds instead of tens of minutes. Hence in test mode when register 300 = 144, the Keep Alive is no longer sent every  $144 \times 10 \text{min} = 1440 \text{minutes}$  or 24h but every  $144 \times 20 \text{s} = 2880 \text{seconds}$  or 48 minutes.
- register S301: the periodicity of the sending of data (periodic mode) is expressed in groups of twenty seconds instead of tens of minutes. Hence in test mode when register 301 = 1, the Keep Alive frame is no longer sent every 10min but every 20 seconds.
- register S332: the periodicity of the data acquisition (event mode) is expressed in tens of seconds instead of minutes. Hence in test mode when register 332 = 1, the Keep Alive frame is no longer sent every minute but every 10 seconds.

-The LEDs also have a different behaviour, allowing a visual feedback to the user in the event of transmission and reception of frames (see paragraph 2.3 for more details).

A complete list of the registers can be found in paragraph 3.4.

E.g.:

Register	Coding the value	Value	Result
S306	Decimal	2	The product is in TEST mode
S300	Decimal	72	The Keep Alive frame is sent every: $72 \times 20 = 1440 \text{s}$ i.e. 24 minutes
S301	Decimal	6	Periodic mode with a period of $6 \times 20 = 120 \text{s}$ i.e. 2 minutes
S332	Decimal	10	In event mode the acquisition period is: $10 \times 10 = 100 \text{seconds}$

### 2.3. Operation of the LEDs

Mode	LED red state	LED green state
Transmission of frame (TEST mode only)		ON during the transmission cycle
Reception of frame (TEST mode only)	ON during the reception of a downlink frame	
Product in Park mode	OFF	OFF
Magnet detection process (1 to 6 seconds)	OFF	ON from detection of the magnet up to a maximum of 1 second
Product start (after detection of the magnet)	OFF	Rapid flashing 6 cycles, 100 ms ON / 100 ms OFF
Joining process (Lora product)	During the JOIN phase: flashing: 50ms on / 1 s off  If the JOIN phase is complete (JOIN accept): flashing: 50ms on / 50ms Off (6x)	During the JOIN phase: flashing: 50ms on / 1 s off (just after the red LED)  If JOIN phase is complete (JOIN accept): flashing: 50ms on / 50ms off (just before the red LED)
Switching to the Command mode	Continuously lit	Continuously lit
Battery level low	Flashing (0.5s ON every 60s)	
Product faulty (return to factory)	Fixed ON	
Product in production mode (TEST mode only)	50ms ON / 50 s OFF	50ms ON / 50 s OFF (just before the red LED)
Product in REPLI mode	Flashing (100ms ON / 100ms OFF) x 2 every 5s	

EN



### 3. DEVICE CONFIGURATION

The device can be configured using the USB connector. This connection allows you to communicate with the device via a virtual com port and to transmit AT commands in order to modify the parameters of the device.

WARNING : the USB connection does not supply power to the product, it induces a consumption of the product as long as the one is connected. It is therefore important not to leave the product connected too long.

#### 3.1. Connecting the device to a computer

Connect the product to the USB input of a computer. The product has a Type B micro USB connector. During connection, the device must be recognised by the computer as a Virtual Com Port (VCP) device.

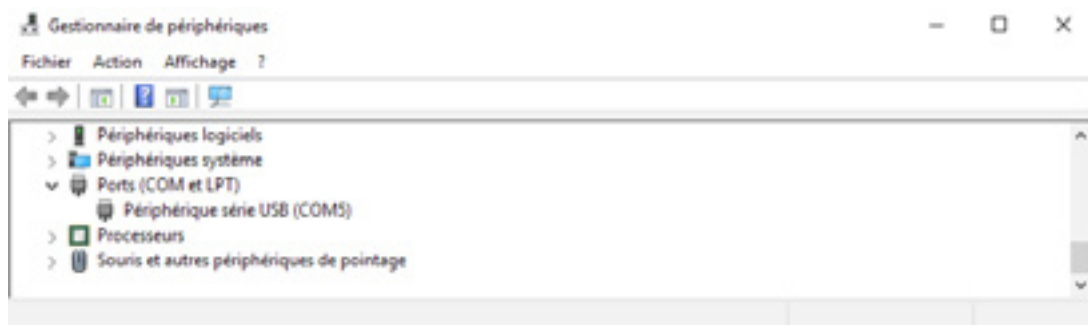

Using Windows: Verification that the device has been recognised to be functioning properly can be obtained by consulting the device manager. You should see the USB series device with a corresponding COM port number appear during connection.

If you are not able to see a device of this type, you must install the USB driver for this device, available to download from our website: <https://www.adeunis.com/en/produit/temp/>

Select:

- Driver USB-STM32\_x64, if your computer is a 64 bits system
- Driver USB-STM32, if your computer is a 32 bits system

### 3.2. Command mode

Use a COM port terminal in order to communicate with the device. We use the HERCULES COM port soft terminal available to download for free by clicking on the following link: [http://www.hw-group.com/devices/hercules/index\\_en.html](http://www.hw-group.com/devices/hercules/index_en.html)

- With Hercules, select the "Serial" tab, then configure the serial port with the following serial parameters:

Parameters	Value
Rate	115 200 bps
Parity	None
Data	8
Stop Bit	1

- Select the serial port on which the device has been created with Windows (Name).
- Click on the "Open" button to open the serial port.

**NOTE INFORMATION** :If the com port has been opened correctly, Hercules will display the message "Serial COM3 port opened". Alternatively, "Serial port com opening error" will be displayed, meaning either that the com port is already open for another application, or it does not exist.

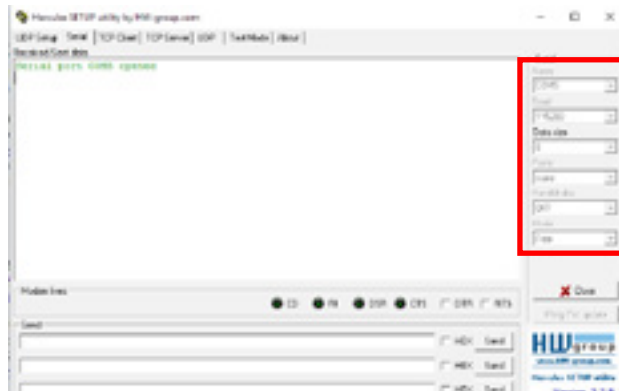

You must send a specific frame in order to move the device to configuration mode. Frame expressed in hexadecimals: 0x2B 0x2B 0x2B or « +++ »

For Hercules, this frame must be entered in one of the 3 lines available at the bottom. The hexadecimal format must be expressed using a "\$" in this program, which gives us the following frame: \$2B\$2B\$2B .



Send the transition frame in command mode in order to switch the device to configuration mode by clicking on the SEND button. After a few seconds, You must see the 2 LEDs light up permanently. On the com port terminal, you should also have "CM" feedback for Command Mode.



Sending a character on Hercules is displayed in magenta and receiving a character is displayed in black. If you do not see sending characters, this is probably because ECHO is not active on this program. To activate the option in the accessible menu, right click in the viewing window.

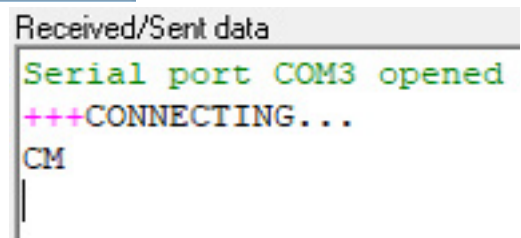

### 3.3. AT commands

A command starts with 2 ASCII characters: "AT", followed by one or more characters and data (see the list below for the syntax of AT commands available on the modem).

Each command must finish with a "CR" or "CR" "LF" – both are acceptable.

(CR indicates: Carriage Return, LF indicates: Line Feed)

Once the command has been received, the modem will feedback:

<cr><lf> "Data" for ATS type playback control <n> ?, AT/S or AT/V

"O" <cr><lf>, for any other command when this has been accepted.

"E" <cr><lf>, if it refuses the command due to a syntax error, unknown command, unknown range, invalid parameter, etc.

"CM" <cr><lf>, if it accepts the input in command mode

Table of AT commands:

Command	Description	Reply example
+++	Input request in command mode	CONNECTING... <cr><lf> CM<cr><lf>
ATPIN <PIN>	Gives access to AT commands if register S304 is different of 0	
AT/V	Feeds back the version of the APPLICATIF and RTU software	APP_8230EAA_PRG1706_V01.02.02:RTU_RTU_WMBUS_868_PRG_1601_V00.00.03 Or APP_8181AAA_PRG1701_V01.00.02:RTU_8120AAB_PRG_1701_V01.00.01
AT/N	Feeds back the type of network	"LoRa" or "SIGFOX" or « WMBUS »
ATS<n>?	Feeds back the content of the n range	Sn=y where y represents the content of the n range
AT/S	Edits the content of all of the user ranges in the form of a list.	/
ATS<n>=<m>	Transfers the m value to the n range	«O»<cr><lf> if Ok, «E»<cr><lf> if error, «W»<cr><lf> if coherency error
AT&W	Saves the current configuration to non-volatile memory.	«O»<cr><lf>, «W»<cr><lf> if coherency error
ATO	Exit command mode	«O»<cr><lf>, «W»<cr><lf> if coherency error
ATT63 PROVIDER	Unblock the operating range	«O»<cr><lf>

Example of a set of commands and corresponding responses that can be seen on the terminal:

Syntax of the order	Description	Response Syntax to Next Line
+++	Input request in command mode	CONNECTING... CM
ATS221=1	Request to switch to activation OTAA mode	O
ATS214=0018B200	Change APP_EUI MSB	E -> This command is not validated (register no unlocked)
ATT63 PROVIDER	Unblock the operating range	O
ATS214=0018B200	Change APP_EUI MSB	O
ATS215?	Feeds back the value of the S215 range	S200=44512451
AT&W	Memory request for the state range	O
ATO	Output request in command mode	O

Interpreting the previous example: the user wanted to modify the beginning of the APP\_EUI after having made an unauthorised command (answer E), and the ranges were unblocked in order to modify the range. The second part of the APP\_EUI was verified and the parameters were saved before exiting. When exiting command mode, the device will start a JOIN demand.

### 3.4. Description of the registers

On switching on the product works according to the last saved configuration (Factory Configuration if it is the first start, or if this configuration has not been changed). Commands such as Modification TTY<n>=<M> or ATR allow you to change the content of the registers: <n> representing the number of the register and <m> the value to be assigned. This latter is either a decimal value or a hexadecimal value consistent with the «encoding» column of the tables below.

Examples:

- ATS300=6 assigns the decimal value 6 in register 300
- ATS320=2 assigns the hexadecimal value 0x02 in register 320

It is imperative to save the parameters with the command AT&W before exiting the Command mode otherwise all changes will be lost.

IMPORTANT: The registers that are not documented (that can appear in the list following the AT/S command) in the paragraphs that follow are reserved and must not be changed.

#### 3.4.1 Function registers

The list of registers below allows you to change the behaviour of the product application.

Register	Size (bytes)	Description	Coding	Details
300	1	Transmission period of the Keep Alive frame	Decimal	Default: 144 Min/max: 1 à 255 Unit: x 10min if S306=1 x 20s if S306=2
301	1	Transmission period of data sensors	Decimal	Default: 1 Min/max: 0 à 255 Unit: x 10min if S306=1 x 20s if S306=2  The value 0 means no periodic sending, therefore event operation
303	1	Confirmed mode activation	Decimal	Default : 0 (desactivated) Values : 0 (desactivated) to 1 (activated)
304	2	PIN code	Decimal	Default : 0 (disabled) Min/max : 0 to 9999  PIN code used with ATPIN command. Value 0 disables the PIN code.  IMPORTANT: The product does not have a mechanism to unlock the PIN code if it is activated and the code is forgotten.
306	1	Global operation	Decimal	Default: 0 Allows the product to be switched into one of the following modes: <ul style="list-style-type: none"> <li>• 0: PARK mode</li> <li>• 1: Production mode</li> <li>• 2: TEST mode</li> <li>• 3: REPLI mode</li> </ul>
320	1	Configuration of the internal sensor	Hexadecimal	Default: 0x00  Bits 0 to 3: Reserved Bits 4 to 7: Identifier (free to use)

321	1	Configuring the event behaviour of the internal sensor	Hexadecimal	Default 0x03 Bits 0 to 1: Threshold triggering • 0 = None • 1 = Low only • 2 = High only • 3 = Low and High  Bits 2 to 7: Reserved
322	1	Configuration of the external sensor	Hexadecimal	See details of register 320
323	1	Configuring the event behaviour of the external sensor	Hexadecimal	See details of register 321
324	4	High threshold value of the internal sensor	Decimal	Default: 300 Min/max: -550 to 1200 (signed value) Units: tenth of °C
325	1	Value of the high threshold hysteresis of the internal sensor:	Decimal	Default: 10 Min/max: 0 of 255 (Unsigned value) Unit: tenth of °C
326	4	Low threshold value of the internal sensor	Decimal	Défaut: 300 Min/max: -550 à 1200 (Unsigned value) Unit: tenth of °C
327	1	Value of the low threshold hysteresis of the internal sensor	Decimal	Default: 10 Min/max: 0 à 255 (Unsigned value) Unit: tenth of °C
328	4	High threshold value of the external sensor	Decimal	Dfaut: 300 Min/max: -550 à 1200 (Unsigned value) Unit: tenth of °C
329	1	Value of the high threshold hysteresis of the iexternal sensor:	Decimal	Default: 10 Min/max: 0 to 255 (Unsigned value) Unit: tenth of °C
330	4	Low threshold value of the external sensor	Decimal	Default: 300 Min/max: -550 à 1200 (Unsigned value) Unit: tenth of °C
331	1	Value of the low threshold hysteresis of the exterbal sensor	Decimal	Default: 10 Min/max: 0 à 255 (Unsigned value) Unit: tenth of °C
332	1	Acquisition period	Decimal	Default: 10 Min/max : 1 à 255 Unité: x 1minute if S306=1 x 10 secondes if S306=2
333	1	Super-sampling factor	Decimal	Default: 5 Min/max: 1 à 10 Unit: aucune

A consistency check will be performed at the time of the registration of the settings via the AT&W command. If one of the following conditions is verified, the command will return «W»:

- Period of transmission = 0 (register 301) and no active threshold (registers 321 and 323)
- Two active thresholds (registers 321 and 323), and the value of the high threshold is less than the value of the low threshold.

### 3.4.2 Network registers

The list of registers below allows you to change the behaviour of the product application. This list is accessible in Provider mode following execution of the ATT63 Provider command.

These registers must be handled with caution because they could cause problems of communication or of non-compliance with the legislation in force.

Register	Description	Coding	Details
201	Spreading Factor (SF) by default	Decimal	Default: 12 (868) or 10 (915) depending on the reference of the product Min/max: 4 to 12 Unit: None
214	LORA APP-EUI (first part – MSB)	Hexadecimal	Default: 0 Key encoded on 16 characters. Each register contains a part of the key. Used during the join phase in OTAA mode  E.g.: APP-EUI = 0018B244 41524632 • S214 = 0018B244 • S215 = 41524632
215	LORA APP-EUI (second part – LSB)	Hexadecimal	
216	LORA APP-KEY (first part– MSB)	Hexadecimal	Default: 0 Key encoded on 32 byte characters. Each of the 4 registers contains 8 characters. Used during the join phase in OTAA mode  E.g.: APP-KEY = 0018B244 41524632 0018B200 00000912 • S216 = 0018B244 • S217 = 41524632 • S218 = 0018B200 • S219 = 00000912
217	LORA APP-KEY (second part – MID MSB)	Hexadecimal	
218	LORA APP-KEY (third part – MID LSB)	Hexadecimal	
219	LORA APP-KEY (fourth part – LSB)	Hexadecimal	
220	LoRaWAN Options	Hexadecimal	Default: 5 Bit 0: Activation of the ADR ON(1)/OFF(0) Bit 1: Reserved Bit 2: DUTYCYCLE ON(1)/DUTYCYCLE OFF(0) Bit 3 to 7: Reserved  WARNING : Deactivation of the Duty Cycle may result in a violation of the conditions of use of the frequency band, depending on the use of the product, thus violating the regulations in force. In the case of disabling the Duty Cycle, the responsibility is transferred to the user.
221	Mode of activation	Decimal	Défaut : 1  Choice: (see NOTE1 after the board) • 0 : ABP • 1: OTAA
222	LORA NWK_SKEY (first part – MSB)	Hexadecimal	Default: 0 Parameter encoded on 16 bytes. Each of the 4 registers contains 4 bytes.
223	LORA NWK_SKEY (second part - MID MSB)	Hexadecimal	
224	LORA NWK_SKEY (third part - MID LSB)	Hexadecimal	
225	LORA NWK_SKEY (fourth part – LSB)	Hexadecimal	

EN

226	LORA APP_SKEY (first part – MSB)	Hexadecimal	Default: 0 Parameter encoded on 16 bytes. Each of the 4 registers contains 4 bytes.
227	LORA APP_SKEY (second part - MID MSB)	Hexadecimal	
228	LORA APP_SKEY (third part - MID LSB)	Hexadecimal	
229	LORA APP_SKEY (fourth part – LSB)	Hexadecimal	
250	Configuration Canal 0	Decimal (868) Hexadecimal (915)	Default: 1 Obligatory LoRaWAN operating channel Do not change this value
251	Configuration Canal 1	Decimal (868) Hexadecimal (915)	Default: 1 (868) ; 0 (915) Obligatory LoRaWAN operating channel Do not change this value
252	Configuration Canal 2	Decimal (868) Hexadecimal (915)	Default: 1 Obligatory LoRaWAN operating channel Do not change this value
253	Configuration Canal 3	Decimal (868) Hexadecimal (915)	Default: 0 (868); 1 (915) 0: Channel disabled Other: User configuration (Note2)
254	Configuration Canal 4	Decimal (868) Hexadecimal (915)	Default: 0 (868); 1 (915) 0: Channel disabled Other: User configuration (Note2)
255	Configuration Canal 5	Decimal (868) Hexadecimal (915)	Default: 0 (868); 1 (915) 0: Channel disabled Other: User configuration (Note2)
256	Configuration Canal 6	Decimal (868) Hexadecimal (915)	Default: 0 (868); 1 (915) 0: Channel disabled Other: User configuration (Note2)
257	Configuration RX2	Decimal (868) Hexadecimal (915)	Default : 1 0 : Channel disabled 1 : Default configuration: LoRaWAN Autre : User configuration
258	Type of tape (only in 915)	Decimal	Default: 3 Min/max: 0 to 3
280	NETWORK ID	Hexadecimal	Default: 0 Lecture seule
281	DEVICE ADDRESS	Hexadecimal	Default: 0

**NOTE 1 :**

The «Over The Air Activation» (OTAA) mode uses a join phase before being able to transmit on the network. This mode uses the APP\_EUI (S214 and S215) and APP\_KEY (S216 to S219) codes during this phase to create the keys for network communication.

Once this phase is completed, the codes APP\_sKEY, NWK\_sKEY and Device address will be present in the corresponding registers.

A new join phase is started every time the product comes out of Command mode, a reset is performed or the product is turned on.

Codes:

- APP\_EUI identifier for global use (provided by default by adeunis®)
- APP\_KEY device application key (provided by default by adeunis®)

The «Activation by personalization» (ABP) mode has no join phase; it transmits directly on the network using the codes NWK\_sKEY (S222 to S225), APP\_sKEY (S226 to S229) and Device address (S281) to communicate.

Codes:

- NWK\_sKEY network session key (provided by default by adeunis®)
- APP\_sKEY applicative session key (provided by default by adeunis®)
- DEVICE ADDRESS Address of the device in the network (provided by default by adeunis®)

**DISTRIBUTED BY TEXIM EUROPE**

**NOTE 2:**

By default, channels 0 to 2 use the default settings of the LoRaWAN network; the other 4 channels are inactive. A register value different from 0 or 1 allows the channel to be configured as follows:

Bit	7	6	5	4	3	2	1	0
<b>Description</b>	Channel frequency						DR Max	DR Min
<b>Example</b>	868100						5	3

Data Rate value (DR)	Description
0	SF12
1	SF11
2	SF10
3	SF9
4	SF8
5	SF7
6	SF7 – BW 250kHz
7	FSK 50 kps

The example given allows the user to configure a frequency of 868.1 Hz and authorizes a SF 7 to 9. The command to be sent to perform this operation is:

```
ATS250=86810053<cr>
```

EN



## 4. DESCRIPTION OF THE FRAMES

### 4.1. Uplink frame

All of the uplink frames of the product to the network (uplink) always have a size of 11 bytes.

#### 4.1.1 Fixed bytes

The first two bytes of the frame are systematically dedicated to indicate the frame code and the status as presented below:

0	1	2	3	4	5	6	7	8	9	10
Code	Statut	PAYLOAD								

##### 4.1.1.01 Byte code

This byte contains the code associated with the frame to facilitate its decoding by the data system.

##### 4.1.1.02 Status Byte

The status byte is broken down in the following way:

Alarm Status	Bit 7	Bit 6	Bit 5	Bit 4	Bit 3	Bit 2	Bit 1	Bit 0
	Frame Counter			Reserved	Reserved	HW	Low Bat	Config
No Error	0x00 to 0x07			X	X	0	0	0
Configuration done				X	X	0	0	1
Low bat				X	X	0	1	0
HW Error				X	X	1	0	0

Details of the fields:

- Frame counter: Frame counter, it increments at each transmission and allows the user to see quickly if a frame has been lost. It counts from 0 to 7 before looping back.
- HW: This bit is set to 1 when a hardware error has occurred, for example a writing problem in the EEPROM, a reading problem on the ADC, etc. The product must be returned to the service dept.
- Low Bat: bit at 1 if the battery voltage is less than 2.5V, otherwise 0. This information remains permanent.
- Config: bit at 1 if a configuration was carried out during the last downlink frame, otherwise 0. This bit returns to 0 as from the next frame.

E.g.:

A value of the status byte equal to 0xA2 (= 10100010 in binary) gives:

- Bit 7 at 5 = 101 = 0x05 i.e. a frame counter at 5
- Bit 4 at 0 = 00010 in binary i.e. a low battery alarm

#### 4.1.2 Frames of information on the product configuration

During the passage into operation mode (from the Park or Command Mode), the following frames (0x10 to 0x12) representing the application configuration of the product are transmitted:

0	1	2	3	4	5	6	7	8	9	10
Code	Status	PAYLOAD								
0x10	Cf Status	S300	S301	S320	S321	S322	S323	S306	Type Ext	S332
0x10	0xA2	0x48	0x00	0xD0	0x03	0x80	0x02	0x01	0x02	0x0A

Description of the frame:

- Byte 2: register 300, periodicity of the Keep Alive frame, expressed in tens of minutes
- Byte 3: register 301, periodicity of transmission (periodic mode), expressed in tens of minutes
- Byte 4: register 320, configuration of the internal sensor
- Byte 5: register 321, configuration of the events of the internal sensor
- Byte 6: register 322, configuration of the external sensor
- Byte 7: register 323, configuration of the events of the external sensor
- Byte 8: register 306, product mode (Park, Standard (production), Test or REPLI)
- Byte 9: type of external sensor:
  - o 0 = disabled
  - o 1 = unknown
  - o 2 = FANB57863-400-1
- Byte 10: register 332, periodicity of the acquisition, expressed in minutes

In the example in grey this gives:

- Byte 2=0x48: register 300, Keep Alive frame transmitted every 12 hours
- Byte 3=0x00: register 301, event mode
- Byte 4=0xD0: Registry 320, identifier of the internal sensor given by the user is equal to 0xD
- Byte 5=0x03: Registry 321: detection of high and low thresholds of the internal sensor
- Byte 6=0x80: Registry 322, identifier of the external sensor given by the user is equal to 0x8
- Byte 7=0x02: Registry 323: detection of high and low thresholds of the external sensor
- Byte 8=0x01: register 306, Production mode in progress
- Byte 9=0x02: The type of the external sensor is FANB57863-400-1
- Octet 10=0x0A: register 332, periodicity of acquisition is 10 minutes

0	1	2 to 3	4	5 to 6	7	8	9	10
Code	Status	PAYLOAD						
0x11	Cf Status	S324	S325	S326	S327	S333	X	X
0x11	0xA2	0x012C	0x0A	0x0032	0x05	0x06		

Description of the frame:

- Bytes 2 to 3: Registry 324, high threshold of the internal sensor, Most Significant Byte first
- Byte 4: register 325, hysteresis of the high threshold of the internal sensor
- Bytes 5 to 6: Registry 326, low threshold of the internal sensor, Most Significant Byte first
- Byte 7: register 327, hysteresis of the low threshold of the internal sensor
- Byte 8: register 333, super-sampling factor

In the example in grey this gives:

- Bytes 2 to 3=0x012C: register 324, the value of the high threshold of the internal sensor is:  $300/10=30^{\circ}\text{C}$
- Bytes 2 to 4=0x0A: register 325, the value of the hysteresis of the high threshold of the internal sensor is:  $10/10=1^{\circ}\text{C}$
- Bytes 5 to 6=x0032: register 326, the value of the high threshold of the internal sensor is:  $50/10=5^{\circ}\text{C}$
- Bytes 2 to 7=0x05: register 327, the value of the hysteresis of the low threshold of the internal sensor is:  $5/10=0.5^{\circ}\text{C}$
- Byte 8=0x06: register 333, the super-sampling factor = 6

0	1	2 to 3	4	5 to 6	7	8	9	10
Code	Status	PAYLOAD						
0x12	Cf Status	S328	S329	S330	S331	X	X	X
0x12	0xA2	0x0190	0x14	0xFED4	0x05			

Description of the frame:

- Bytes 2 to 3: Registry 328, high threshold of the external sensor, Most Significant Byte first
- Byte 4: register 329, hysteresis of the high threshold of the external sensor
- Bytes 5 to 6: Registry 330, low threshold of the external sensor, Most Significant Byte first
- Byte 7: register 331, hysteresis of the low threshold of the external sensor



In the example in grey this gives:

- Bytes 2 to 3=0x0190: register 328, the value of the high threshold of the external sensor is:  $400/10=40^{\circ}\text{C}$
- Byte 4=0x14: register 329, register 329, the value of the hysteresis of the high threshold of the external sensor is:  $20/10=2^{\circ}\text{C}$
- Bytes 5 to 6=0xFED4: register 330, the register being signed the hexadecimal value  $0xFED4 = -300$ . Hence the value of the low threshold of the external sensor is:  $-300/10=-30^{\circ}\text{C}$
- Byte 7=0x05: register 331, the value of the hysteresis of the low threshold of the external sensor is:  $5/10=0.5^{\circ}\text{C}$

#### 4.1.3 Frame of information on the network configuration

During the passage into operation mode (from the Park or Command Mode), the following frame (0x20) representing the network configuration of the product is transmitted:

0	1	2	3	4	5	6	7	8	9	10
Code	Status	PAYLOAD								
0x20	Cf Status	ADR	MODE	X	X	X	X	X	X	X
0x20	0xA2	0x01	0x01							

Description of the frame:

- Byte 2: activation of the Adaptive Data Rate: ON (value = 1) or OFF (value = 0)
- Byte 3: connection mode: ABP (value = 0) or OTAA (value = 1)

In the example in grey this gives:

- Byte 2=0x01: The Adaptive Data Rate is enabled
- Byte 3=0x01: OTAA connection mode

#### 4.1.4 Keep Alive frame

This frame (0x30) is transmitted only in the event mode at the frequency defined by register 300. It contains the same fields as the data frame (0x43):

0	1	2	3	4	5	6	7	8	9	10
Code	Status	PAYLOAD								
0x30	Cf Status	internal sensor identifier	Value read on the internal sensor	external sensor identifier	Value read on the internal sensor					X
0x30	0xA2	0xD1	0x015E	0x82	0xFF06					

Description of the frame:

- Byte 2:
  - o Bits 0 to 3:
    - 0: unknown/absent/error
    - 1: CTN internal sensor B57863S0321F040
  - o Bits 4 to 7: The user identifier defined in register 320
- Bytes 3 to 4: Value measured on the internal sensor
  - Signed value on 16 bits,
  - Expressed in tenths of degrees,
  - Most Significant Byte first
  - The special value 0x8000, equivalent to  $-3276, 8^{\circ}\text{C}$  is returned in the event of a fault in the sensor.
- Byte 5:
  - o Bits 0 to 3:
    - 0: unknown/absent/error
    - 1: unknown

- o Bits 4 to 7: The user identifier defined in register 322
- Bytes 6 to 7: Value measured on the internal sensor
  - Signed value on 16 bits,
  - Expressed in tenths of degrees,
  - Most Significant Byte first
  - The special value 0x8000, equivalent to -3276, 8°C is returned in the event of a fault in the sensor.

In the example in grey this gives:

- Byte 2=0xD1:
  - o Bits 0 to 3 = 0x1: The internal sensor is present
  - o Bits 4 à 7 = 0xD: the identifier of the internal sensor defined by the user is equal to 0xD
- Bytes 3 to 4=0x015E: The value measured on the internal sensor is 350/10=35°C
- Byte 5=0x82:
  - o Bits 0 to 3 = 0x2: The external sensor is of the type external CTN sensor FANB57863-400-1
  - o Bits 4 to 7 = 0x8: the identifier of the internal sensor defined by the user is equal to 0x8
- Bytes 6 to 7=0xFF06: as this field is signed the hexadecimal value 0xFF06 = -250. Hence the value measured on the external sensor is -250/10=-25°C

#### 4.1.5 Reply frame to a register value request in a downlink frame

Following reception of a downlink frame with the code 0x40, the frame 0x31 is transmitted. It contains all the values of the registers requested in the downlink frame 0x40.

- Frame (0x40) sent to the product (downlink) :

0	1	2	3	4	5	...	n
Code	PAYLOAD						
0x40	CONFID1	CONFID2	CONFID3	X	X	X	CONFIDn

The CONFIDX (8bits) fields represent the indices of the registers to be sent. The corresponding register is 300 + CONFIDX value.

- Response frame (0x31) from the product:

0	1	2	3	4	5	...	11
Code	Status	PAYLOAD					
0x31	Cf. Status	VALUE1	VALUE1	VALUE2	VALUE3	VALUE3	X

In this example: CONFID1 is a 2-byte register, CONFID2 a 1-byte register and CONFID3 a 2-byte register. If an error is detected in the request, the returned 0x31 frame will be empty.



#### 4.1.6 Data Frame

This frame (0x43) contains the values measured on the different sensors.

0	1	2	3	4	5	6	7	8	9	10
Code	Status	PAYLOAD								
0x43	Cf Status	internal sensor identifier	Value read on the internal sensor	External sensor identifier	Value read on the internal sensor					X
0x43	0xA2	0xD1	0x015E	0x82	0xFF06					

Description of the frame:

- Byte 2:
  - o Bits 0 to 3:
    - 0: unknown/absent/error
    - 1: CTN internal sensor B57863S0321F040
  - o Bits 4 to 7: The user identifier defined in register 320
- Bytes 3 to 4: Value measured on the internal sensor
  - Signed value on 16 bits,
  - Expressed in tenths of degrees,
  - Most Significant Byte first
  - The special value 0x8000, equivalent to -3276,8°C is returned in the event of a fault in the sensor.
- Byte 5:
  - o Bits 0 to 3:
    - 0: unknown/absent/error
    - 1: unknown
    - 2: CTN external sensor FANB57863-400-1
  - o Bits 4 to 7: The user identifier defined in register 322
- Bytes 6 to 7: Value measured on the internal sensor
  - Signed value on 16 bits,
  - Expressed in tenths of degrees,
  - Most Significant Byte first
  - The special value 0x8000, equivalent to -3276,8°C is returned in the event of a fault in the sensor.

In the example in grey this gives:

- Byte 2=0xD1:
  - o Bits 0 to 3 = 0x1: The internal sensor is present
- o Bits 4 to 7 = 0xD: the identifier of the internal sensor defined by the user is equal to 0xD
- Bytes 3 to 4=0x015E: The value measured on the internal sensor is 350/10=35°C
- Byte 5=0x82:
  - o Bits 0 to 3 = 0x2: The external sensor is of the type external CTN sensor FANB57863-400-1
  - o Bits 4 to 7 = 0x8: the identifier of the internal sensor defined by the user is equal to 0x8
- Bytes 6 to 7=0xFF06: as this field is signed the hexadecimal value 0xFF06 = -250. Hence the value measured on the external sensor is -250/10=-25°C

### 4.1.7 Summary of the conditions of the transmission of the uplink frames

The table below summarizes the conditions of the transmission of the different uplink frames:

Code	Description	Sending conditions
0x10 0x11 0x12	Product configuration data frames	<ul style="list-style-type: none"> <li>Start-up of the product</li> <li>Exit from the configuration mode</li> <li>Reception of a downlink frame 0x01</li> </ul>
0x20	Frames of information on the network configuration	<ul style="list-style-type: none"> <li>Start-up of the product</li> <li>Exit from the configuration mode</li> <li>Reception of a downlink frame 0x02</li> </ul>
0x30	Keep Alive frame	<ul style="list-style-type: none"> <li>Periodically in "event" mode</li> </ul>
0x31	Reply frame to a register value request in a downlink frame	<ul style="list-style-type: none"> <li>Reception of a downlink frame 0x40</li> </ul>
0x43	Data Frame	<ul style="list-style-type: none"> <li>Start-up of the product</li> <li>Passing a threshold (event mode)</li> <li>The end of the period (periodic mode)</li> </ul>



## 4.2. Downlink frames

LoRaWAN technology makes it possible to transmit information to the product from the network (downlink frame).

The class A of the LoRaWAN specification allows the product to receive information from the network by proposing two listening windows after each uplink communication (uplink frame).

### 4.2.1 Product configuration request frame

This frame allows us to inform the product via the network that it must resend the product configuration uplink frame (0x10).

0	1	2	3	4	5	6	7
Code	PAYLOAD						
0x01	X	X	X	X	X	X	X

### 4.2.2 Network configuration request frame

This frame allows us to inform the product via the network that it must resend the network configuration uplink frame (0x20).

0	1	2	3	4	5	6	7
Code	PAYLOAD						
0x02	X	X	X	X	X	X	X

### 4.2.3 Specific register value request frame

This frame (0x40) allows to inform the product via the network that it must send the values of specific registers in a uplink frame (0x31).

0	1	2	3	4	5	...	n
Code	PAYLOAD						
0x40	CONFID1	CONFID2	CONFID3	X	X	X	CONFIDn

Description of the frame:

- Bytes 1 to N : CONFIDX (8bits): indice of the register to be sent. The corresponding register is  $300 + \text{CONFIDX}$  value. For example, if CONFID1 = 20, the product will send back the value of register number 320.

The associated uplink frame has the code 0x31 (see paragraphe 4.1.5).

0	1	2	3	4	5	...	11
Code	PAYLOAD						
0x31	Status	VALUE1	VALUE1	VALUE2	VALUE3	VALUE3	X

In this example: CONFID1 is a 2-byte register, CONFID2 a 1-byte register and CONFID3 a 2-byte register.

If an error is detected in the request, the returned 0x31 frame will be empty.

**IMPORTANT :** The user can specify several CONFIDs in his downlink frame but it is his responsibility to verify that according to the protocol the size of the data available in a downlink frame will be large enough to contain all the desired data. Otherwise, the application will only send the first values.

### 4.2.4 Frame for updating the value of specific registers

This frame (0x41) allows to change the value of requested registers.

0	1	2	3	4	5	...	n
Code	PAYLOAD						
0x41	CONFID1	CONFID1 value	CONFID2	CONFID2 value (MSB)	CONFID2 value (LSB)	...	CONFIDn value

Description of the frame :

- Byte 1: CONFID1 (8bits) : indice of the first register to change. The corresponding register is  $300 + \text{value of CONFIDX}$ . For example, if CONFID1 = 20, the product will change the value of register number 320.
- Byte 2: value to assign to CONFID1 : in this example, its value has a size of 1 byte
- Byte 3: CONFID2 (8bits) : indice of the second register to change. The corresponding register is  $300 + \text{value of CONFIDX}$ .
- Bytes 4 and 5: value to assign to CONFID2 : in this example, its value has a size of 2 bytes
- ...

The product does not return any uplink frame following the reception of a downlink frame 0x41. However, the Config bit of the status byte (see section 4.1.1.2) will be set to 1 in the next scheduled uplink frame (periodic or alarm or keep alive frame) if all was well done.

**IMPORTANT:** the value 0xFF for a CONFIDX will stop the reading of the downlink frame. Only the bytes preceding this value 0xFF will be taken into account. This mechanism can be useful when you need to work in fixed downlink frame lengths and you do not want to use all available bytes.

## 5. START-UP

### 5.1. Starting up the product using a magnet

Once the product has been configured and its assembly has been finalised, the product is ready to be started up.

The start-up is carried out using a magnet which you place on the upper part of the product (cf. the diagram below). The magnet must be held in position for at least 6 seconds so as to confirm the start-up of the product. When the magnet is well detected, the green LED lights up for 1 second.

Once the LoRaWAN TEMP unit validates its start-up, it immediately transmits status frames followed by a data frame (according the defined periodicity).

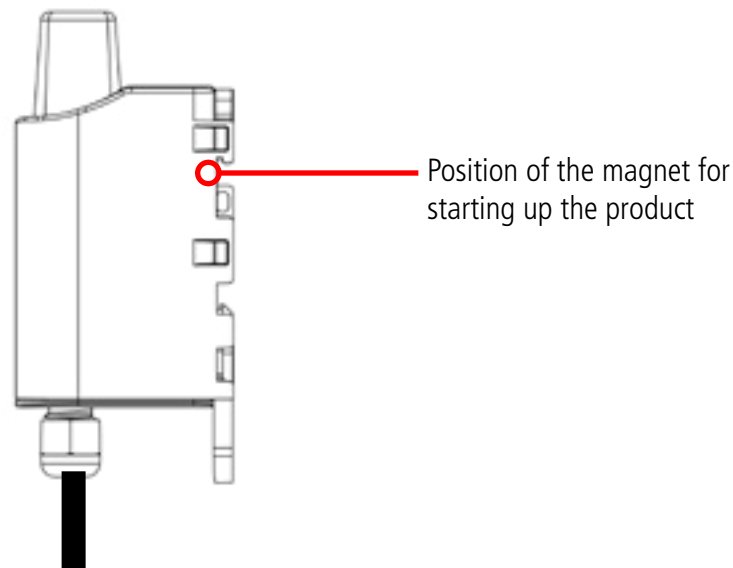

EN

### 5.2. Replacing the battery

When the low battery indicator is activated (indicator in the frame or flashing of the red LED), it is possible to change the internal battery of the unit.

It is important to use a battery of the same reference, SAFT LS14500.

Procedure to change the battery:

1. Open the unit
2. Remove the battery and replace it with the new one respecting the polarity as indicated on the electronic card
3. Close the unit
4. Restart the product with the magnet as for a first start

After this procedure the product will behave as during a first start.

Battery location

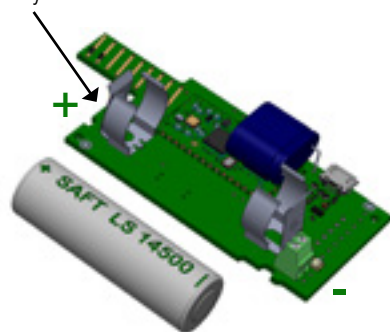

Disposition of the battery on the card

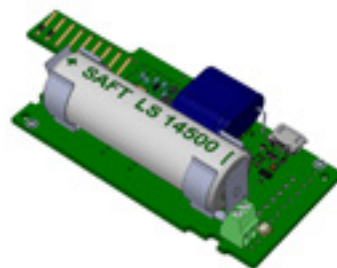



### 5.3. Closing the casing

Once previous stages have been carried out, you can close the casing of the LoRaWAN TEMP

Procedure:

1. Make sure that the seal is properly positioned on the base
2. Clip the electronic board onto the casing's base. Make sure that the fastening clip is properly locked into the board's fitting.
3. Insert the upper part of the casing. Inside this part there are guide rails for the board. Make sure that the board is properly positioned within these guides.
4. Once the board is in position, lower the upper cover and lock it onto the casing's base. Strong pressure will enable both parts to be clipped together and will enable protection level IP67 to be ensured.
5. Finish the assembly by locking the packing gland's nut in position

EN

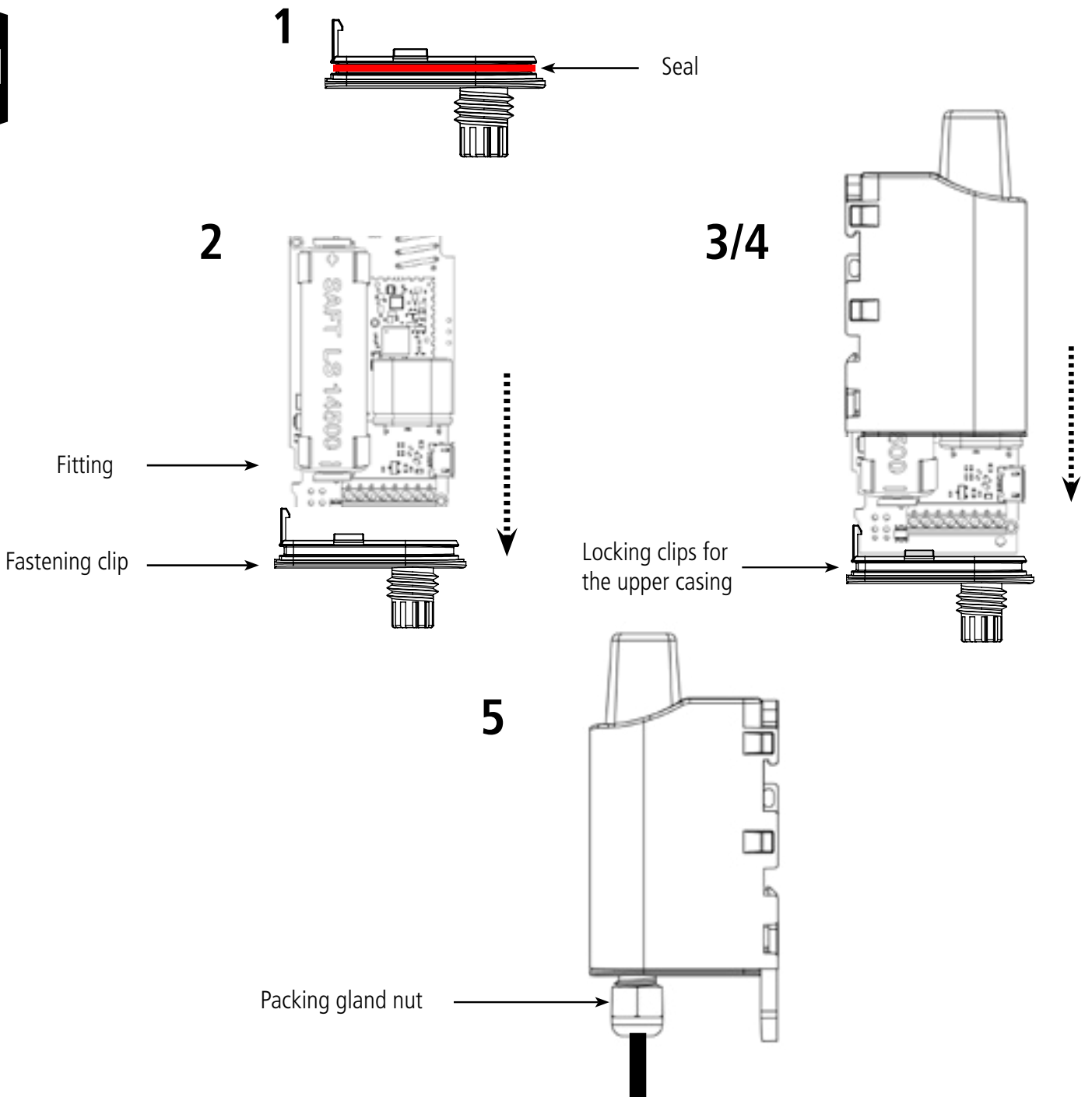

## 6. INSTALLATION AND USE

### 6.1. Correct positioning of the product transceivers

There are two key rules for optimising radio ranges.

- The first one consists of positioning your product as high as possible.
- The second one consists of limiting the number of obstacles in order to avoid excessive attenuation of the radio wave.

**Position:** To the extent possible, install the transmitter at a minimum height of 1.50 m and do not attach it to the wall.

**Obstacles:** Ideally, the product must be 20 cm away from any obstacle and, if possible, near an opening (the closer the obstacle is, the more the emitted power will be absorbed). All the materials encountered by a radio wave will attenuate it. Bear in mind that metal (metal cabinets, beams, etc.) and concrete (reinforced concrete, partitions, walls, etc.) are the most critical materials for the propagation of radio waves.

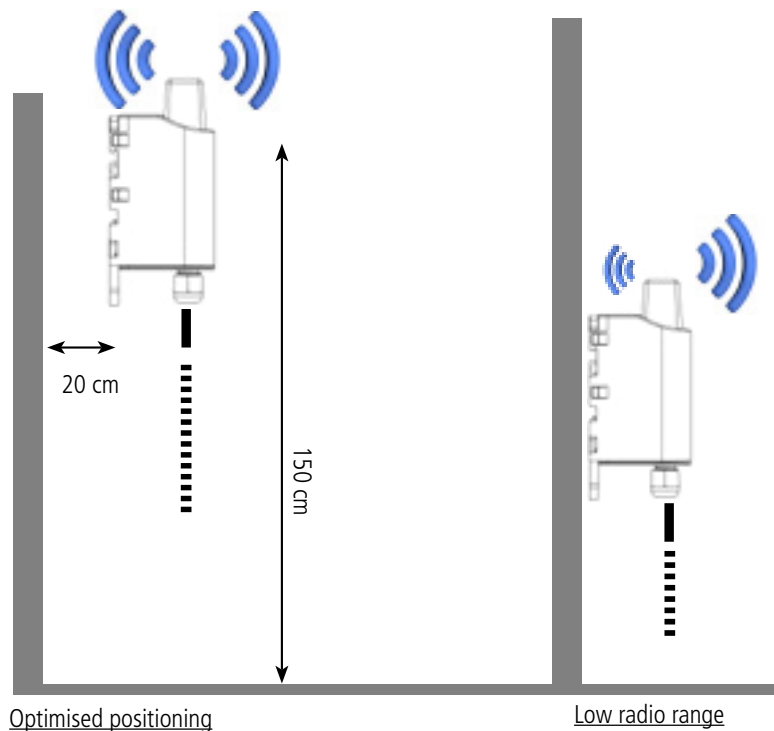

EN

### 6.2. Types of fastenings

The product offers 3 fastening methods that enable numerous ways of positioning it depending on the environment where it has to be deployed.

#### 6.2.1 Tube or mast fastenings

As explained in section 4.1, the best radio performance is achieved by positioning the product as high as possible.

The fastening collar fastenings enable the product to be fastened on a mast or tube under completely safe conditions

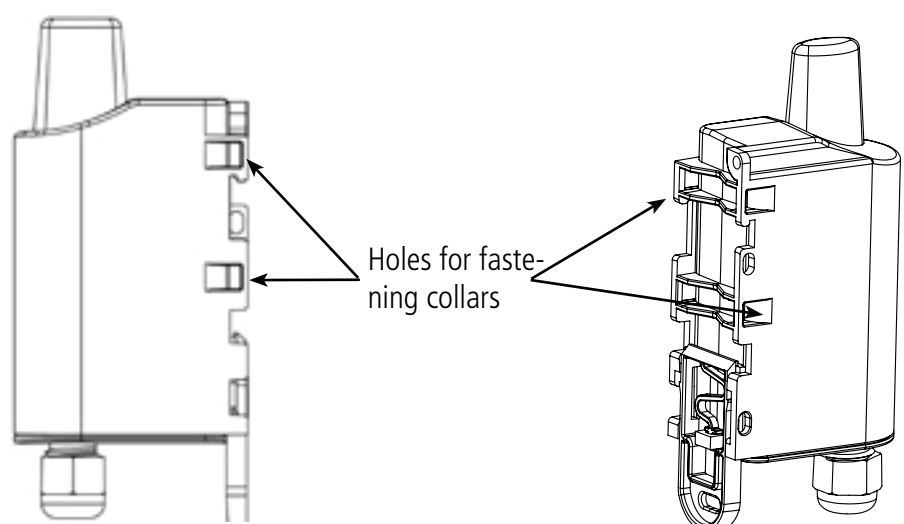

To optimise fastening onto a tube or mast, we recommend you remove the Rail-DIN locking/unlocking lever.

To remove it, pull the lever down until the locking pins are opposite a freed-up part and then remove the lever

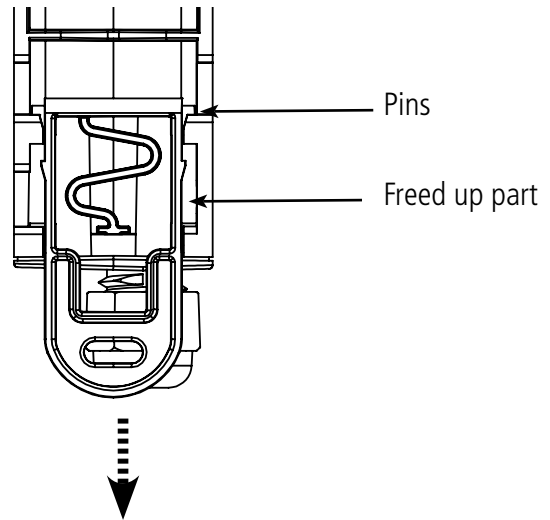

EN

### 6.2.2 Fixing with screws

The product is delivered with 2 CBLZ 2.2 x 19 mm screws and 2 SX4 wall plugs. Use these products or equivalent products in order to fasten your product onto a flat support.

Two positions may be selected: Laid flat or on its edge.

- Placing it on its edge enables the product to be placed at a distance from its support and helps achieve better propagation of the radio waves.
- If you opt for laying it flat, make sure you remove the Rail-DIN locking/unlocking lever, as explained above

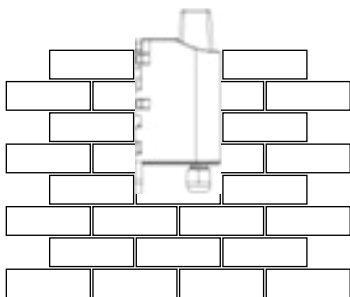
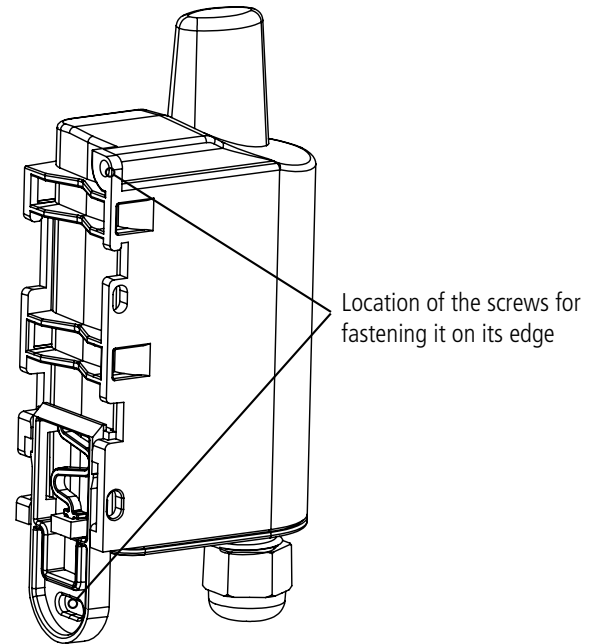
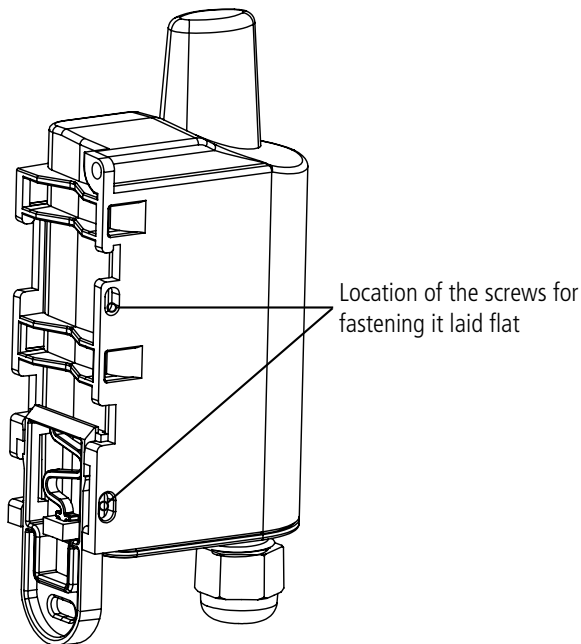

Fastening laid flat

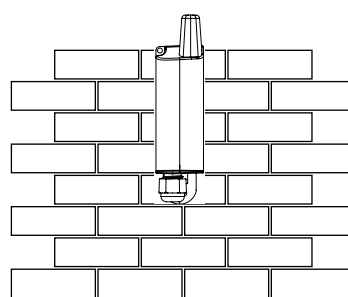

Fastening on its edge

### 6.2.3 DIN-Rail fixing

This system, integrated into the casing, enables the product to be fastened onto a standard 35 mm rail.

- To fit the casing, place the upper inserts on the rail and lower the product to clip it into position.
- To remove the product, pull the unlocking lever down and disengage the product from the rail.

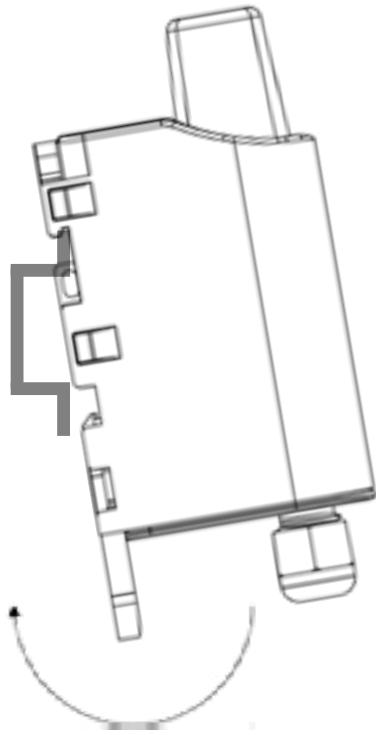

Locking onto the DIN-Rail

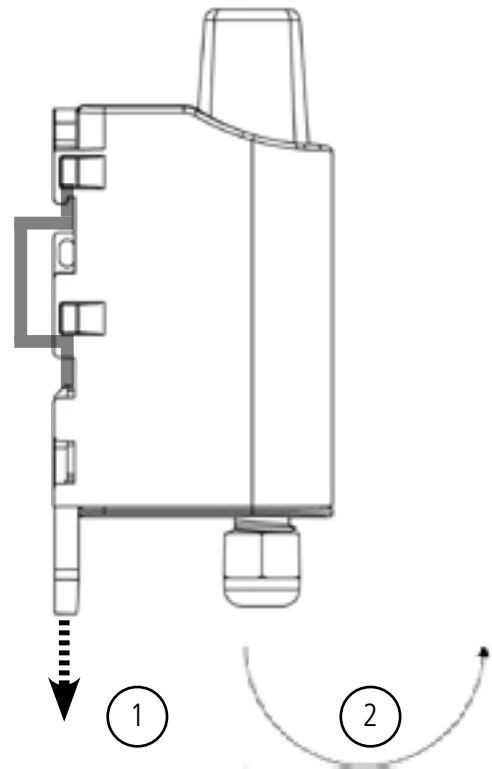

Unlocking

EN

## 7. DOCUMENT HISTORY

Version	Contents
V1.0.0	Creation
V1.0.1	Update Declaration of Conformity
V1.2.0	Update Part 3
V2.0.0	Changes after update RTU & APP

# **DEUTSCH**

# **Vorschriften**

DE

## HAFTUNGSAUSSCHLUSS

Dieses Dokument und die Nutzung aller darin enthaltenen Informationen setzt das Einverständnis mit den Bestimmungen und Bedingungen von adeunis® voraus.

adeunis® übernimmt keine Garantie für die Richtigkeit oder Vollständigkeit des Inhalts dieses Dokuments und behält sich das Recht vor, jederzeit und ohne Vorankündigung Änderungen an den Produktspezifikationen und -beschreibungen vorzunehmen.

adeunis® behält sich alle Rechte an diesem Dokument und den darin enthaltenen Informationen vor. Die Vervielfältigung, Nutzung oder Weiterverbreitung an Dritte ohne ausdrückliche Genehmigung ist streng untersagt. Copyright © 2016, adeunis®.

adeunis® ist eine eingetragene Marke in den EU-Staaten und anderen Ländern.

## TECHNISCHER SUPPORT

### Website

Unsere Website enthält viele nützliche Informationen: Informationen zu Produkten und Zubehör, Benutzeranleitungen, Konfigurationssoftware und technische Dokumente, die rund um die Uhr abrufbar sind.

### E-Mail

Falls Sie technische Probleme haben oder nicht die benötigten Informationen in den bereitgestellten Dokumenten finden können, setzen Sie sich per E-Mail mit unserem technischen Support in Verbindung. Verwenden Sie unsere eigens dafür vorgesehene E-Mail-Adresse (support@adeunis.com) anstelle einer persönlichen E-Mail-Adresse. Auf diese Weise wird sichergestellt, dass Ihre Anfrage so schnell wie möglich bearbeitet wird.

### Nützliche Informationen bei Kontaktierung unseres technischen Supports

Wenn Sie unseren technischen Support kontaktieren, halten Sie bitte folgende Informationen bereit:

- Produkttyp
- Firmware-Version
- Klare Beschreibung Ihrer Frage oder Ihres Problems
- Ihre vollständigen Kontaktdaten

DE

## VORBEMERKUNG

Alle Rechte an dieser Anleitung liegen ausschließlich bei . Alle Rechte vorbehalten. Die Vervielfältigung dieser Anleitung (ohne schriftliches Einverständnis des Eigentümers) mittels Drucken, Kopieren, Speichern oder in anderer Weise, die Übersetzung dieser Anleitung (vollständig oder teilweise) in jedwede Sprache, einschließlich aller Programmiersprachen, unter Verwendung jeglicher elektrischer, mechanischer, magnetischer, optischer, manueller Geräte oder anderer Methoden, ist untersagt.

adeunis® behält sich das Recht vor, ohne schriftliche Bekanntgabe und ohne ausdrückliches Verlangen seiner Kunden die technischen Spezifikationen oder Funktionen seiner Produkte zu ändern und sicherzustellen, dass die ihnen zur Verfügung gestellten Informationen gültig sind.

Die -Konfigurationssoftware und -programme adeunis® werden in einer unveränderlichen Version kostenlos bereitgestellt. adeunis® kann für einen bestimmten Typ von Anwendungen keinerlei Garantie übernehmen, auch keine Gewähr für deren Eignung und Verwendbarkeit. Der Hersteller oder Vertreiber eines -Programms kann auf keinen Fall für etwaige Schäden infolge der Nutzung dieses Programms haftbar gemacht werden. Die Namen der Programme sowie alle Urheberrechte im Zusammenhang mit den Programmen sind ausschließliches Eigentum von adeunis®. Jedwede(r) Übertragung, Lizenzierung an Dritte, Vermietung, Verleih, Überführung, Kopie, Bearbeitung, Übersetzung, Veränderung in einer anderen Programmiersprache oder Rückwärtsentwicklung (Reverse-Engineering) ohne die schriftliche Genehmigung und Zustimmung von ist untersagt.

### Adeunis

283, rue Louis Néel  
38920 Crolles  
Frankreich

Telefon +33 (0)4 76 92 07 77

Fax +33 (0)4 76 04 80 87

## UMWELTSCHUTZHINWEISE

Es wurden alle überflüssigen Verpackungsmaterialien vermieden. Wir haben uns bemüht, dass die Verpackung leicht in drei Materialarten getrennt werden kann: Pappe (Schachtel), expandiertes Polystyrol (Puffermaterial) und Polyethylen (Tüten, Schaumstoff-Schutzlage). Ihr Gerät besteht aus recycelbaren Materialien, die im Falle einer Demontage durch ein Fachunternehmen wiederverwendet werden können. Bitte beachten Sie die vor Ort geltenden Vorschriften zur Entsorgung der Verpackungsabfälle, verbrauchten Batterien und Ihres Altgeräts.

## WARNHINWEISE



Lesen Sie die Hinweise in dieser Anleitung.



Die Sicherheit dieses Produkts wird nur für eine bestimmungsgemäße Verwendung gewährleistet. Die Wartung darf nur von einer qualifizierten Person durchgeführt werden.

Achtung: Das Gerät nicht in der Nähe einer Wärme- oder Feuchtigkeitsquelle installieren.

Achtung: Bei Öffnung des Geräts keine anderen als die in dieser Anleitung vorgesehenen Vorgänge durchführen.



Achtung: Das Produkt nicht öffnen – Gefahr eines Stromschlags.



Achtung: Zu Ihrer Sicherheit muss vor jedem technischen Eingriff am Gerät dieses stromlos geschaltet werden.



Achtung: Zu Ihrer Sicherheit muss der Stromversorgungskreis des Produkts vom Typ SELV (Sicherheitskleinspannung) sein und es sich um Stromquellen mit begrenzter Leistung handeln.

Bitte beachten Sie: Wenn die Antenne draußen installiert ist, ist es notwendig, den Kabelschirm mit der Erdung des Gebäudes zu verbinden. Wir empfehlen den Blitzschutz. Der gewählte Schutzkit muss das Koaxialkabel wie geerdet haben (zB: Koaxial-Blitzableiter mit Erdung des Kabels an verschiedenen Stellen auf der Antenne an der Basis von Pylonen und am Eingang oder kurz vor dem Betreten der Räumlichkeiten).

Das Produkt muß mit einem Schaltmechanismus zum Abschalten des elektrischen Stroms ausgestattet werden, welche sich in der Nähe der Ausrüstung befinden muss. Jede elektrische Verbindung des Produktes muß mit einer Schutzvorrichtung gegen Spannungsspitzen und Kurzschlüsse ausgestattet werden.

DE



## GEBRAUCHSHINWEISE

- Überprüfen Sie vor Benutzung des Systems, ob die in dessen Betriebsanleitung angegebene Versorgungsspannung mit Ihrer Stromquelle übereinstimmt. Falls nicht, wenden Sie sich an Ihren Lieferanten.
- Stellen Sie das Gerät auf eine ebene, feste und stabile Oberfläche.
- Das Gerät muss an einem ausreichend belüfteten Standort installiert werden, um jedes Risiko einer internen Überhitzung auszuschließen, und es darf nicht mit Objekten wie Zeitungen, Decken, Gardinen usw. abgedeckt werden.
- Das Gerät darf auf keinen Fall Hitzequellen wie Heizgeräten ausgesetzt werden.
- Stellen Sie das Gerät nicht in der Nähe brennender Gegenstände wie Kerzen, Lötbrennern, usw. auf.
- Das Gerät darf keinen aggressiven Chemikalien oder Lösungsmitteln ausgesetzt werden, die den Kunststoff angreifen oder die Metallteile korrodieren könnten.
- Das Terminal muss am Gürtel mit Hilfe eines dafür vorgesehenen Clips getragen werden.

## ENTSORGUNG VON ABFÄLLEN DURCH DIE NUTZER IN PRIVATHAUSHALTEN IN DER EUROPÄISCHEN UNION



Dieses Symbol auf dem Produkt oder auf seiner Verpackung bedeutet, dass dieses Produkt nicht mit anderem Hausmüll entsorgt werden darf. Stattdessen obliegt es Ihrer Verantwortung, Ihre Abfälle zu einer benannten Sammelstelle für die Wiederverwertung von Elektro- und Elektronikaltgeräten zu bringen. Getrenntes Sammeln und Recyceln bei der Entsorgung Ihrer Abfälle trägt zur Bewahrung der natürlichen Ressourcen und zu einer umweltverträglichen Wiederverwertung sowie zum Schutz der menschlichen Gesundheit bei. Für weitere Informationen zum nächstgelegenen Recyclingzentrum wenden Sie sich an das nächste Rathaus, den Entsorgungsdienst für Haushaltsabfälle oder das Geschäft, in dem Sie das Produkt gekauft haben.



Dieses Symbol auf dem devode Gerät oder seiner Verpackung bedeutet den Gebrauch einer Gleichstrom-Spannung.



Achtung: Es besteht Explosionsgefahr, wenn die Batterien durch einen falschen Typ ersetzt werden. Entsorgen Sie die Batterien gemäß den Gebrauchshinweisen. Beim Wechsel der Batterien muss das Produkt wieder richtig und ordnungsgemäß zusammengesetzt werden.



WICHTIG für die Schweiz: Für die Batterien muss Anhang 4.10 der Norm SR 814.013 Anwendung finden.

## The Netherlands



Elektrostraat 17  
NL-7483 PG Haaksbergen

T: +31 (0)53 573 33 33  
F: +31 (0)53 573 33 30  
E: [nl@texim-europe.com](mailto:nl@texim-europe.com)

## Belgium



Zuiderlaan 14 bus 10  
B-1731 Zellik

T: +32 (0)2 462 01 00  
F: +32 (0)2 462 01 25  
E: [belgium@texim-europe.com](mailto:belgium@texim-europe.com)

## UK & Ireland



St. Mary's House, Church Lane  
Carlton Le Moorland  
Lincoln LN5 9HS

T: +44 (0)1522 789 555  
F: +44 (0)845 299 22 26  
E: [uk@texim-europe.com](mailto:uk@texim-europe.com)

## Germany North



Bahnhofstrasse 92  
D-25451 Quickborn

T: +49 (0)4106 627 07-0  
F: +49 (0)4106 627 07-20  
E: [germany@texim-europe.com](mailto:germany@texim-europe.com)

## Germany South



Martin-Kollar-Strasse 9  
D-81829 München

T: +49 (0)89 436 086-0  
F: +49 (0)89 436 086-19  
E: [germany@texim-europe.com](mailto:germany@texim-europe.com)

## Austria



Warwitzstrasse 9  
A-5020 Salzburg

T: +43 (0)662 216 026  
F: +43 (0)662 216 026-66  
E: [austria@texim-europe.com](mailto:austria@texim-europe.com)

## Nordic region



Sdr. Jagtvej 12  
DK-2970 Hørsholm

T: +45 88 20 26 30  
F: +45 88 20 26 39  
E: [nordic@texim-europe.com](mailto:nordic@texim-europe.com)

## General information



[info@texim-europe.com](mailto:info@texim-europe.com)  
[www.texim-europe.com](http://www.texim-europe.com)