

WLRS-591EVB series

LoRa IoT Module

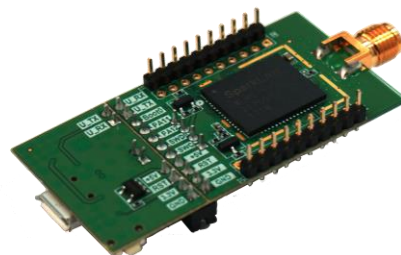

Low Power Wide Area Network Solution

This LPWAN WLRS-591EVB integrates WLRS-590 that provides ultra –long range spread spectrum communication and high interference immunity.

The WLRS-590 is designed & manufactured in a smallest form factor -SiP (System in Package). WLRS-590 integrates with Semtech SX1276 and a 32-bit ultra-low power Cortex M0+ MCU (STM32L073x), supporting 863-915MHz ISM-Bands.

This product is designed with multiple easy to use interfaces (I2C/SPI/UART/GPIO), For faster development, SparkLAN provides WLRS-591EVB. The WLRS-591EVB equips with a UART-To-USB bridge IC and can be powered by USB. Besides, a SMA antenna connector is also provided for easy antenna installation. WLRS-590 module provides a commands set interface that can use LoRa and LoRaWAN communication through UART interface.

Key Feature :

- +20dBm constant RF output vs. V supply
- Programmable bit rate up to 37500 bps
- High sensitivity down to -137 dBm
- Excellent blocking immunity
- Preamble detection
- Automatic RF sense and CAD with ultra-fast AFC
- Payload up to 128 bytes with CRC
- Embedded memories (up to 192k bytes of Flash memory and 20k bytes of RAM)
- 3x UART

Distributed by:



Specification :

MCU	STM32L073xZ ARM Coretex-M0+ 32-bit
Chipset	Semtech SX1276
Frequency	EU 863-870 MHz ISM Band US 902-928 MHz ISM Band AS923 MHz ISM Band (Japan 920-928 MHz)
Flash memory / RAM	192k bytes / 20k bytes
Interface	1x micro USB, 1x SMA Femal, 1x Reset button
Antenna connector	SMA Female connector
Transmitter Power	20dBm
Receive Sensitivity	-137 dBm
Temperature	-40°C to + 85°C(Operating) -50°C to + 105°C(Storage)
Humidity	Operating: 10~95% (No-Condensing) Storage: 5~95% (No-Condensing)
Input Voltage	3.3V
Dimension	L:48mm x W:25mm

Detail in the flowing table

Frequency Range	Spreading Factor	Bandwidth (K Hz)	Effective Bitrate (bps)	Est. Sensitivity (dBm)
863-870MHz 902-928 MHz	6-12	62.5 - 500	146 - 37500	-109 to -137

LoRa setting SF=12, BW=62.5k, Long-Range Mode, highest LNA gain, LnaBoost for Band 1.

OptionalFW support for European band 868MHz

Electrical Characteristics
Absolute Maximum Ratings

Symbo	Parameter	Min	Typ.	Max.	Unit
VDD33	Supply Voltage	-0.3		3.9	v
V _{IN}	Input voltage on digital pins	-0.3		3.9	v
P _{mr}	RF Input Level			+10	10dBm

Recommended Operating Range

Symbo	Parameter	Min.	Typ.	Max.	Unit
VDD33	Supply Voltage	2.4	3.3	3.6	V
ML	RF Input Level			+10	dBm

Power Consumption Characteristics

Symbo	Parameter	Conditions	Typ.	Max.	Unit
IDDSL	Supply current in Sleep mode			TBD	uA
IDDST	Supply current in Standby mode	Crystal oscillator enabled	9	9.6	mA
IDDR	Supply current in Receive mode		17.5		mA
IDDT	Supply current in Transmit mode with impedance matching	RFOP= +20 dBm RFOP= +17 dBm RFOP= +13 dBm RFOP= +7 dBm	127 82 65 49		mA

RF Characteristics

The table gives the electrical specifications for the transceiver operating with LoRa Modulation

Supply voltage	3.3V
Temperature	25°C
Frequency bands	915 MHz /868MHz
Bandwidth(BW)	125 KHz
Spreading Factor(SF)	12
Error Correction Code (EC)	4/6
Packet Error Rate (PER)	1%
Output power	13 dBm in transmission
CRC on payload	enabled
Payload length	64 bytes
Preamble Length	12 symbols (programmed register preamblelength=8)
With matched impedances	

LoRa Transmitter (Conductive)

Item	Condition	Min.	Typ.	Max.	Unit
Frequency Range	Band 1		915		MHz
Tx Power Level	PA_BOOST pin	18	19.5	21	dBm

LoRa Receiver (Conductive)

Item	Condition	Min.	Typ.	Max.	Unit
Frequency Range	Band 1	863	915	928	MHz
RFS_L62_HF (Long-Range Mode, highest LNA gain, LNAboost, 62.5 kHz bandwidth)	SF = 6		-119		dBm
	SF = 7		-114		dBm
	SF = 8		-127		dBm
	SF = 12		-137		dBm
RFS_L500_HF (Long-Range Mode, highest LNA gain, LNA boost, 500 kHz bandwidth)	SF = 6		-109		dBm
	SF = 7		-114		dBm
	SF = 8		-117		dBm
	SF = 9		-120		dBm
	SF = 10		-123		dBm
	SF = 11		-126		dBm
	SF = 12		-128		dBm

Digital Characteristics
DC characteristics
Input voltage levels

Symbol	Description	Conditions	Min	Typ.	Max	Unit
VIH	I/O input high level voltage	NRST	0.7xVDD33	-	-	v
		BOOT0	0.7xVDD33	-	-	v
		GPIO	0.7xVDD33	-	-	v
VIL	I/O input low level voltage	NRST	-	-	0.3xVDD33	v
		BOOT0	-	-	0.14xVDD33	v
		GPIO	-	-	0.3xVDD33	v
R _{PU}	Weak pull-up Equivalent resistor	V _{IN} = GND	30	45	60	KΩ
R _{PD}	Weak pull-down Equivalent resistor	V _{IN} = VDD33	30	45	60	KΩ

Output voltage levels

Symbol	Description	Conditions	Min	Max	Unit
V _{OL}	Output low level voltage for an I/O pin	CMOS port / IIO = +8mA 2.7V ≤ VDD33 ≤ 3.6V	-	0.4	V
V _{OH}	Output high level voltage for an I/O pin		VDD33-0.4	-	V
V _{OL}	Output low level voltage for an I/O pin	TTL port / IIO = +8 mA 2.7V ≤ VDD33 ≤ 3.6V	-	0.4	V
V _{OH}	Output high level voltage for an I/O pin	TTL port / IIO = -6 mA 2.7V ≤ VDD33 ≤ 3.6V	2.4	-	V
V _{OL}	Output low level voltage for an I/O pin	IIO = + 15 mA 2.7V ≤ VDD33 ≤ 3.6V	-	1.3	V
V _{OH}	Output high level voltage for	IIO = - 15 mA 2.7V ≤ VDD33 ≤ 3.6V	VDD33-1.3	-	V

	an I/O pin				
V _{OL}	Output low level voltage for an I/O pin	I _{IO} = + 4 mA 1.65 V ≤ VDD33 ≤ 3.6V	-	0.45	V
V _{OH}	Output high level voltage for an I/O pin	I _{IO} = + 4 mA 1.65 V ≤ VDD33 ≤ 3.6V	VDD33-0.45	-	V

NRST pin characteristics

The NRST pin input driver uses CMOS technology. It is connected to a permanent pull-up resistor (R_{PU})
The following figure is recommended NRST pin protection circuit against parasitic resets.

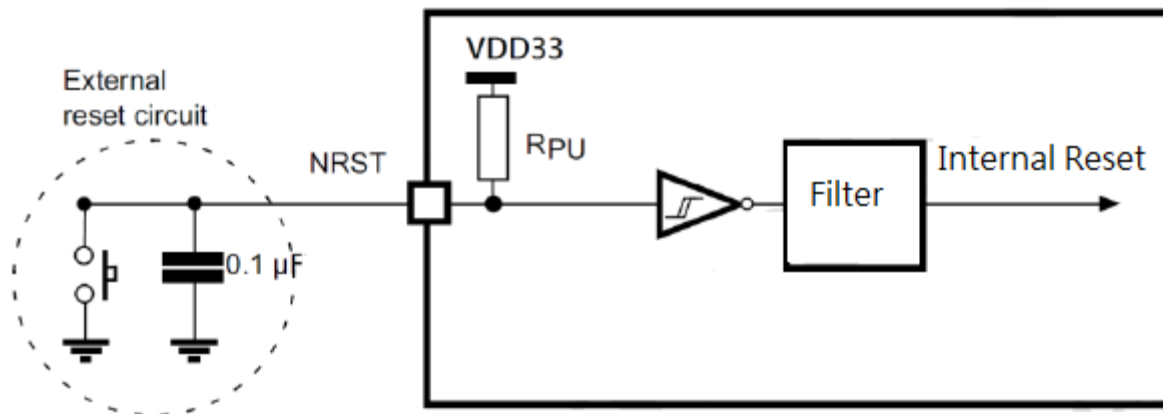

Symbol	Description	Conditions	Min	Typ.	Max	Unit
V _{IL} (NRST)	NRST input low level voltage		VSS		0.8	V
V _{IH} (NRST)	NRST input high level voltage		1.4		VDD33	V
V _{OL} (NRST)	NRST output low level voltage	I _{OL} = 2 mA 2.7V < VDD33 < 3.6V			0.4	V
V _{OL} (NRST)	NRST output low level voltage	I _{OL} = 1.5 mA 1.65V < VDD33 < 2.7V			0.4	V
V _{hys} (NRST)	NRST Schmitt trigger			10% VDD33		mV

	voltage hysteresis					
R _{PU}	Weak pull-up Equivalent resistor	V _{IN} = GND	30	45	60	kΩ
V _F	NRST Input filtered pulse				50	nS
V _{NF}	NRST Input not filtered pulse	VDD33 > 2.7V		350		nS

UART Interface Parameters

Baud Rate = 38400 bps

Data Bits = 8 bits

Stop Bits = 1 bit

Parity Check = None

Flow Control = None

Pin Definition

WLRS-591EVB	WLRS-590	STM32L073X (MCU)
None	pin1	No connection
GND	pin2	GND
GND	pin3	GND
PC0 for ADC/I2C3 SCL	pin4	PC0
PC1 for ADC/I2C3 SDA	pin5	PC1
PC2 for ADC/SPI2 MISO	pin6	PC2
PC3 for ADC/SPI2 MOSI	pin7	PC3
None	pin8	No connection
None	pin9	No connection
None	pin10	No connection
None	pin11	No connection
GND	pin3	GND
RST	pin12	MCU_RESET
PA0 for ADC/USART4 TX	pin13	PA0
GND	pin14	GND
GND	pin15	GND
PA2 for ADC/USART2 TX	pin16	PA2_TXD_A

PA3 for ADC/USART2 RX	pin17	PA3_RXD_A
PA4 for SPI1 NSS/USART2 CK	pin18	PA4_SPI1_NSS
PA5 for SPI1 SCK/ADC	pin19	PA5_SPI1_SCK
PA6 for SPI1 MISO/ADC	pin20	PA6_SPI1_MISO
PA7 for SPI1 MOSI/ADC	pin21	PA7_SPI1_MOSI
PC4 for ADC	pin22	PC4
PC5 for ADC	pin23	PC5
PB0 for ADC	pin24	PB0_IO_INT1
PB1 for ADC/I2C2 SDA	pin25	PB1_IO_INT2
PC6	pin26	PC6
PC7	pin27	PC7
PC8	pin28	PC8
PC9 for DAC/I2C3 SDA	pin29	PC9
RXTX Switch	pin30	RXTX/RFMOD
GND	pin31	GND
GND	pin32	GND
RF_ANT	pin33	No connection
GND	pin34	GND
GND	pin35	GND
PA1 for RF RXTX Switch	pin36	PA1_RF_FEM_CPS
GND	pin37	GND
None	pin38	No connection
GND	pin39	GND
None	pin40	No connection
GND	pin41	GND
None	pin42	No connection
VDD_3.3V	pin43	VDD33
VDD_3.3V	pin44	VDD33
PA8 for USART1_CK/I2C3 SCL	pin45	PA8_USART1_CK
PA10 for USART1 RX/I2C1 SDA	pin46	PA10_USART1_RX
PA9 for USART1 TX/I2C1 SCL	pin47	PA9_USART1_TX
PA11 for USART1 CTS/SPI1 MISO/USB DM	pin48	PA11_USART1_CTS
PA12 for USART1 RTS/SPI1 MOSI	pin49	PA12_USART1_RTS
PA13 for SWDIO	pin50	PA13_SWDIO

PA14 for SWCLK	pin51	PA14_SWCLK
PC10 for USART4 TX	pin52	PC10
PC11 for USART4 RX/ADC	pin53	PC11
PC12 for USART5 TX/USART4 CK	pin54	PC12
PD2 for USART5 RX	pin55	PD2
PB5 for USART5 RTS/SPI1 MOSI	pin56	PB5
PB6 for USART1 TX/ I2C1 SCL	pin57	PB6_SCL
PB7 for I2C1 SDA/USART1 RX/USART4 CTS	pin58	PB7_SDA
BOOT0	pin59	BOOT0
PB8 for I2C1 SCL	pin60	PB8_IO_LED_FCT
GND	pin61	GND
GND	pin62	GND

Breakout Pin Definition

Top View

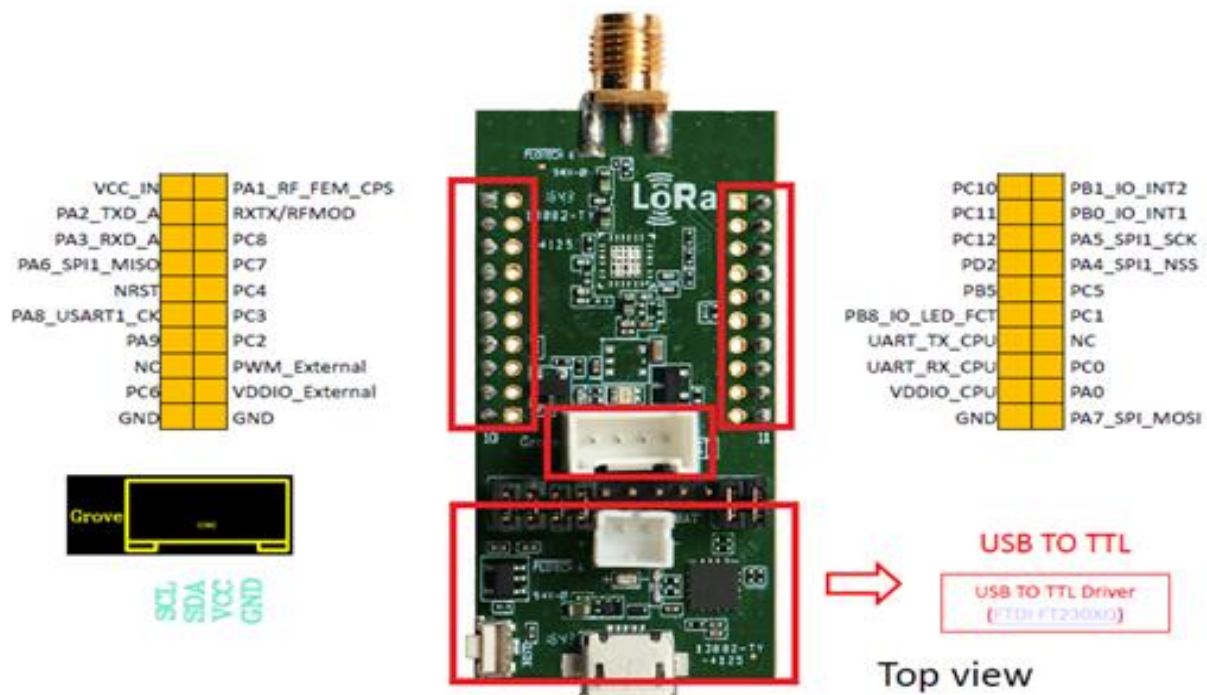

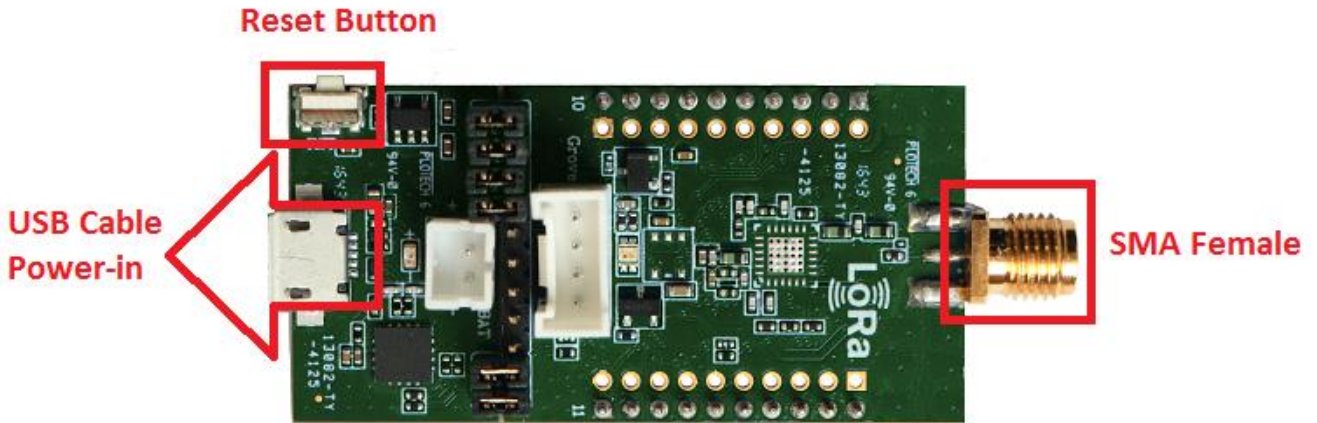

Bottom View

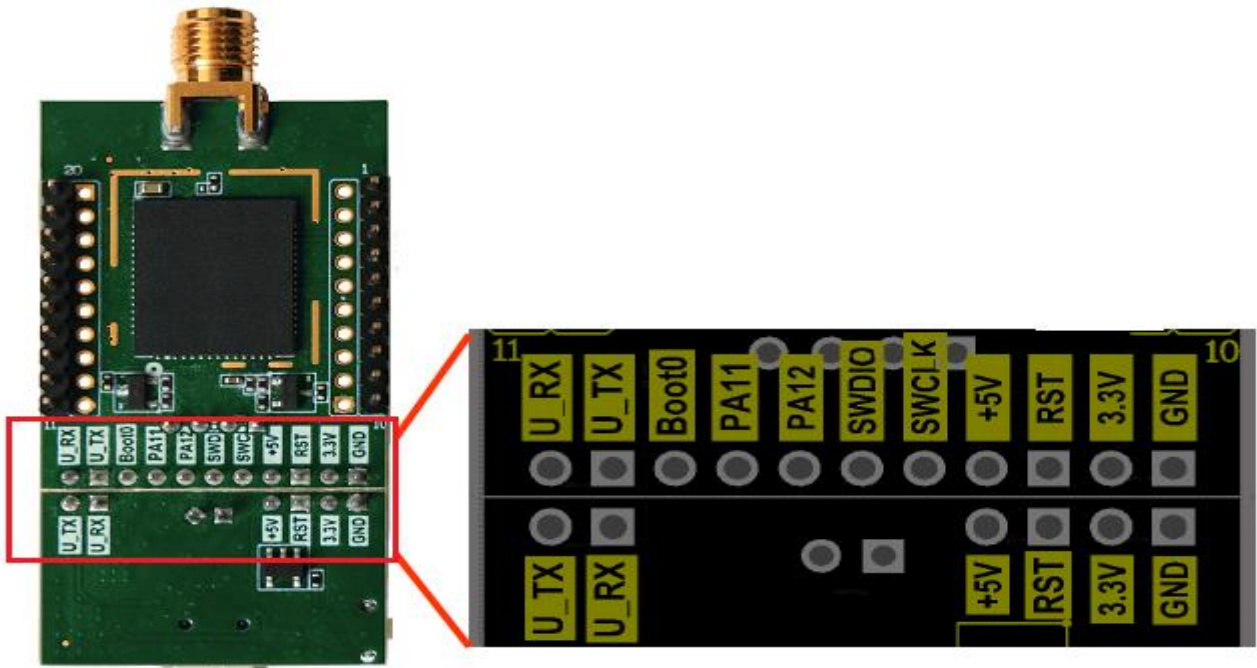

WLRS-591 order information

Model No.	Product Description
WLRS-591EVB (EU)	LoRa IoT Module (EU 863-870MHz)
WLRS-591EVB (US)	LoRa IoT Module (US 902-928MHz)
WLRS-591EVB (AS)	LoRa IoT Module (AS923MHz)

*External antenna optional

The Netherlands



Elektrostraat 17
NL-7483 PG Haaksbergen

T: +31 (0)53 573 33 33
F: +31 (0)53 573 33 30
E: nl@texim-europe.com

Belgium



Zuiderlaan 14 bus 10
B-1731 Zellik

T: +32 (0)2 462 01 00
F: +32 (0)2 462 01 25
E: belgium@texim-europe.com

UK & Ireland



St. Mary's House, Church Lane
Carlton Le Moorland
Lincoln LN5 9HS

T: +44 (0)1522 789 555
F: +44 (0)845 299 22 26
E: uk@texim-europe.com

Germany North



Bahnhofstrasse 92
D-25451 Quickborn

T: +49 (0)4106 627 07-0
F: +49 (0)4106 627 07-20
E: germany@texim-europe.com

Germany South



Martin-Kollar-Strasse 9
D-81829 München

T: +49 (0)89 436 086-0
F: +49 (0)89 436 086-19
E: germany@texim-europe.com

Austria



Warwitzstrasse 9
A-5020 Salzburg

T: +43 (0)662 216 026
F: +43 (0)662 216 026-66
E: austria@texim-europe.com

Nordic region



Sdr. Jagtvej 12
DK-2970 Hørsholm

T: +45 88 20 26 30
F: +45 88 20 26 39
E: nordic@texim-europe.com

General information



info@texim-europe.com
www.texim-europe.com