

## 3.5" SubCompact Board with Intel® Pentium® N4200/ Celeron® N3350 Processor SoC

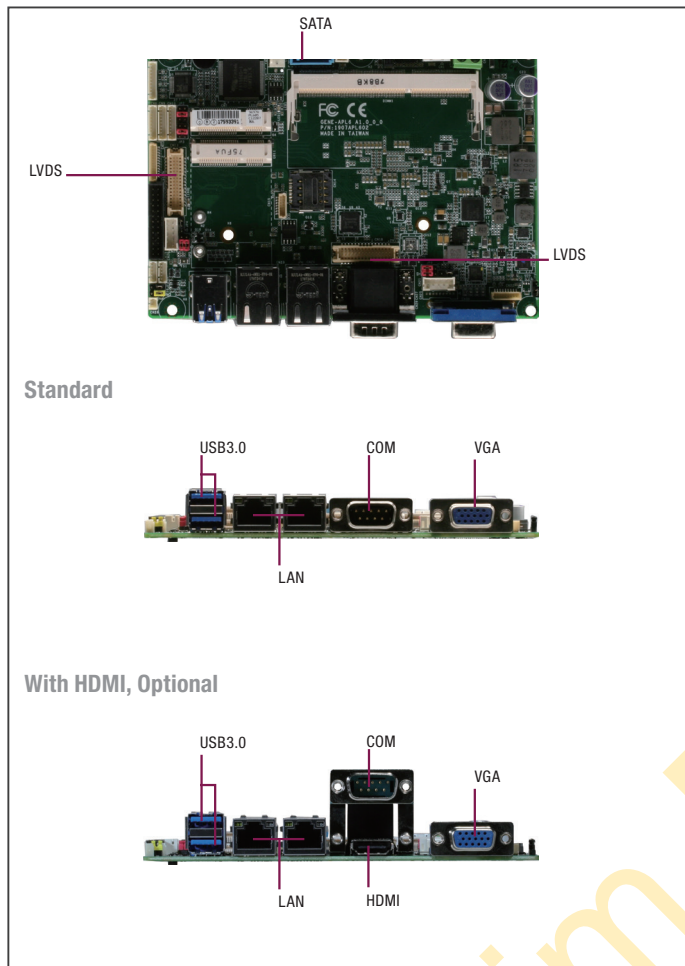

Standard

With HDMI, Optional

## Specifications

System	
Form Factor	3.5" SubCompact Board
CPU	Intel® Pentium® N4200/ Celeron® N3350 Processor SoC
CPU Frequency	up to 2.5GHz
Chipset	Intel® Pentium® N4200/ Celeron® N3350 Processor SoC
Memory Type	DDR3L 1866MHz, SODIMM x 1
Max. Memory Capacity	Up to 8GB
BIOS	UEFI
Wake on LAN	Yes
Watchdog Timer	255 Levels
Power Requirement	+9~36V or +12V
Power Supply Type	AT/ ATX
Power Consumption (Typical)	Intel® N4200, DDR3L 1600MHz 8G, 1.55A@ +12V
Dimension (L x W)	5.75" x 4" (146mm x 101.7mm)
Operating Temperature	32°F ~ 140°F (0°C ~ 60°C)
Storage Temperature	-40°F ~ 176°F (-40°C ~ 81°C)
Operating Humidity	0% ~ 90% relative humidity, non-condensing
MTBF (Hours)	128,793
Certification	CE/FCC
Display	
VGA/LCD Controller	Intel® Pentium® N4200/ Celeron® N3350 Processor SoC
Video Output	LVDS, LVDS2, VGA (HDMI is option, co-layout with LVDS2)
Backlight Inverter Supply	Yes

## Features

- Intel® Pentium® N4200/ Celeron® N3350 Processor SoC
- DDR3L 1866 MHz SODIMM x 1, up to 8 GB
- VGA/LVDS/LVDS2 (HDMI Co-layout with LVDS2 Optional)
- 2 CH Audio, SATA 6.0 Gb/s x 1, eMMC up to 64G (Optional)
- Supports 8-bit Digital I/O, USB 2.0 x 2, USB 3.0 x 2, COM x 4
- Mini Card x 1 (Full-size), mSATA x 1 (Half-size)
- 9~36V wide DC input or +12V only (Optional), AT/ATX Mode
- Supports TPM (Optional)
- 4/5/8-wire Resistive Touch Screen Controller (Optional)



I/O	
Ethernet	Intel® i210/I211, 10/100/1000Base-TX, RJ-45 x 2
Audio	High Definition Audio Interface
USB Port	USB 3.0 x 2 USB 2.0 x 2
Serial Port	RS-232 x 2, RS-232/422/485 x 2
Parallel Port	SPP/EPP/ECP x 1 (Option, Shared with DIO)
HDD Interface	SATA 3.0 x 1 +5V SATA power connector x 1
FDD Interface	—
SSD	eMMC 16G/32G/64G (optional)
Expansion Slot	Mini Card x 1 (Full-size) mSATA x 1 (Half-size)
DIO	8-bit
SIM	x 1 (uSIM)
TPM	TPM 2.0 x 1 (option)
Touch	x 1 (option)

## Packing List

- Product DVD
- GENE-APL6 with Heat Spreader

## Optional Accessories

Part Number	Description	QTY
1700050207	(TF)USB CABLE.1*5P Pitch=1.25mm Housinh.20cm.for PFM-945C	2
1701090150	(TF)Flat Cable.D-Sub 9(M).9P Housing.9P 1.25mm pitch Housing.15cm	3
1709100254	(TF)PHONE JACK Cable.3P AUDIO JACK.1*10P 1.25mm HOUSING(F).25cm	1
1709070500	(TF)SATA CABLE.7P Pitch 1.27mm.50cm	1
1702150155	(TF)Power Cable.15P SATA(F).2P 2.0mm Housing(PH).15cm	1
170220020B	(TF)Power Cable.20P ATX(M).4P 5.08mm Housing(F).+3P 2.5mm Housing(XH).20cm	1
GENE-APL6-HSK01	HeatSink.146X80X14mm.Silver.GENE-APL6.(used with heat spreader)	1
1702002010	(TF)Power CABLE. 1*2P Pitch=5.0mm Housing. 10cm. for PFM-945C. (12V only)	1

## Block Diagram

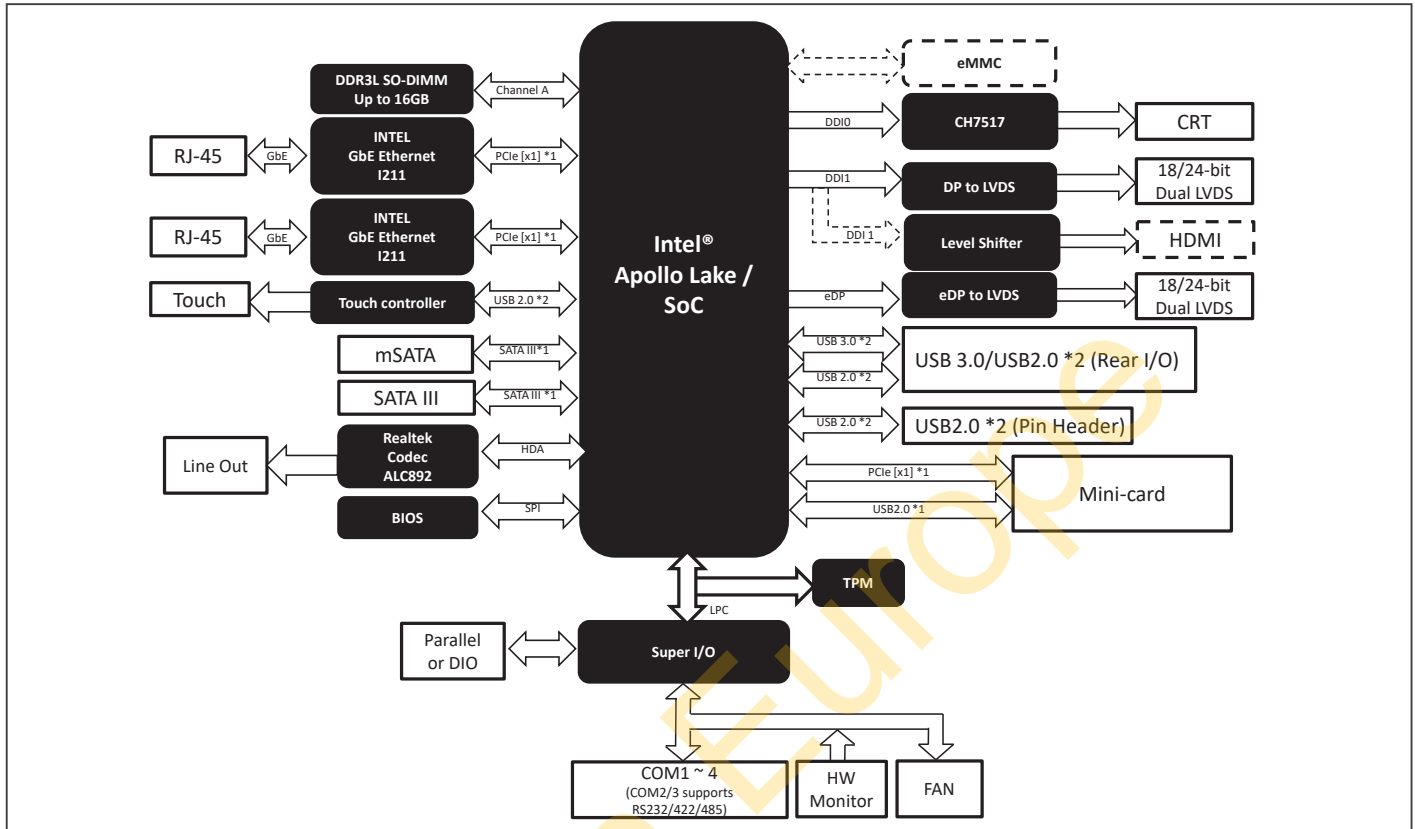

## Dimension

Unit: mm

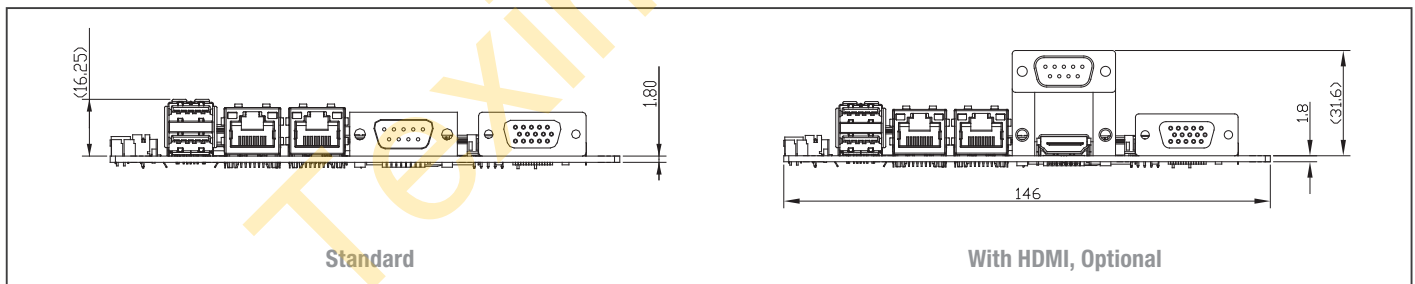

## Ordering Information

Part Number	CPU	Fan/Fanless	Display	LVDS	Storage	LAN	USB	RS-232	RS-232/422/485	Expansion Slot	Power	Power Temp	Others
GENE-APL6-A10-0001	N3350	HSP	VGA, LVDS, LVDS2	24bit, 2CH	SATA x 1 mSATA x 1	GbE x 2	USB 3.0 x 2 USB 2.0 x 2	2	2	MiniCard x 1 (Full-size)	9-36V	0°C - 60°C	DIO x 8
GENE-APL6-A10-0002	N3350	HSP	VGA, LVDS, LVDS2	24bit, 2CH	SATA x 1 eMMC 32G	GbE x 2	USB 3.0 x 2 USB 2.0 x 2	2	2	MiniCard x 1 (Full-size)	9-36V	0°C - 60°C	Touch Controller, SIM, TPM, DIO x 8

Distributed by:



## The Netherlands



Elektrostraat 17  
NL-7483 PG Haaksbergen

T: +31 (0)53 573 33 33  
F: +31 (0)53 573 33 30  
E: [nl@texim-europe.com](mailto:nl@texim-europe.com)

## Belgium



Zuiderlaan 14 bus 10  
B-1731 Zellik

T: +32 (0)2 462 01 00  
F: +32 (0)2 462 01 25  
E: [belgium@texim-europe.com](mailto:belgium@texim-europe.com)

## UK & Ireland



St. Mary's House, Church Lane  
Carlton Le Moorland  
Lincoln LN5 9HS

T: +44 (0)1522 789 555  
F: +44 (0)845 299 22 26  
E: [uk@texim-europe.com](mailto:uk@texim-europe.com)

## Germany North



Bahnhofstrasse 92  
D-25451 Quickborn

T: +49 (0)4106 627 07-0  
F: +49 (0)4106 627 07-20  
E: [germany@texim-europe.com](mailto:germany@texim-europe.com)

## Germany South



Martin-Kollar-Strasse 9  
D-81829 München

T: +49 (0)89 436 086-0  
F: +49 (0)89 436 086-19  
E: [germany@texim-europe.com](mailto:germany@texim-europe.com)

## Austria



Warwitzstrasse 9  
A-5020 Salzburg

T: +43 (0)662 216 026  
F: +43 (0)662 216 026-66  
E: [austria@texim-europe.com](mailto:austria@texim-europe.com)

## Nordic region



Sdr. Jagtvej 12  
DK-2970 Hørsholm

T: +45 88 20 26 30  
F: +45 88 20 26 39  
E: [nordic@texim-europe.com](mailto:nordic@texim-europe.com)

## General information



[info@texim-europe.com](mailto:info@texim-europe.com)  
[www.texim-europe.com](http://www.texim-europe.com)