

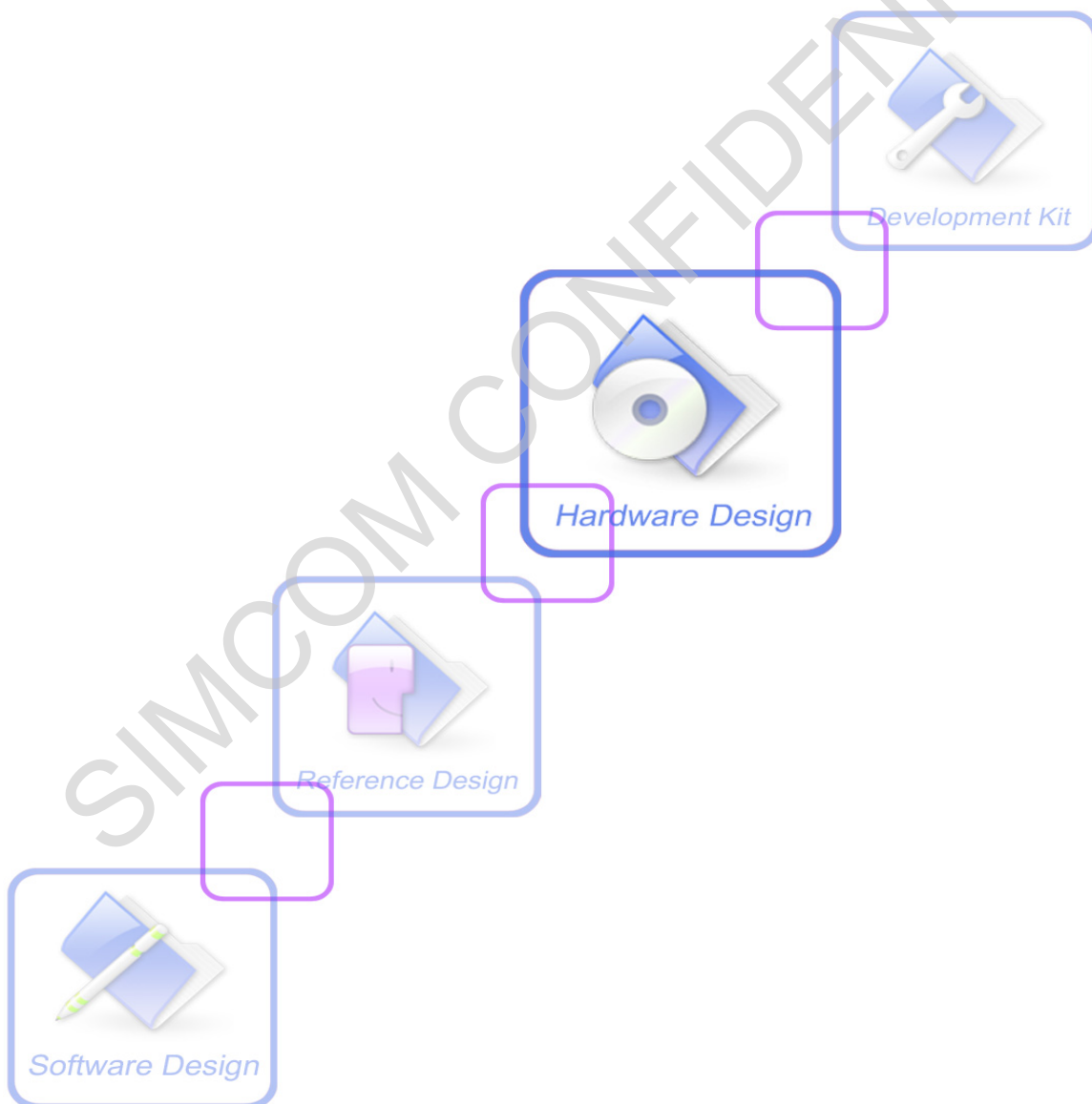

a SUSEA MDT company

SIM7000-PCIE_Hardware Design_V1.00



Document Title	SIM7000 -PCIE Hardware Design
Version	1.00
Date	2018-11-08
Status	Release
Document Control ID	SIM7000 -PCIE_Hardware_Design_V1.00

General Notes

SIMCom offers this information as a service to its customers to support the application and engineering efforts that use the products designed by SIMCom. The information provided is based on the requirements specifically from the customers. SIMCom has not undertaken any independent search for additional relevant information, including any information that may be in the customer's possession. Furthermore, the system validation of the product designed by SIMCom within a larger electronic system remains the responsibility of the customer or the customer's system integrator. All specifications supplied herein are subject to change without notice.

Copyright

This document contains the proprietary technical information which is the property of SIMCom Limited, copying of this document, giving it to others, the using or communication of the contents thereof are forbidden without the official authority by SIMCom. Offenders are liable to the payment of the damages. All rights are reserved in the event of grant of a patent or the registration of a utility model or design. All specifications supplied herein are subject to change without notice

Copyright © SIMCom Wireless Solutions Co., Ltd. 2018

Contents

General Notes	2
Copyright	2
Contents	3
Table Index	5
Figure Index	6
Version History	7
1. Introduction	8
1.1 Product Outline.....	8
1.2 Hardware Interface Overview.....	9
1.3 Hardware Block Diagram.....	10
1.4 Functional Overview.....	10
2. Package Information	12
2.1 Pin Out Diagram.....	12
2.2 PCI Express Mini Card Connector Pin Description.....	13
2.3 Package Dimensions.....	15
3. Interface Application	16
3.1 Power Supply.....	16
3.2 PERST#.....	17
3.3 W_DISABLE#.....	18
3.4 LED_WWAN#.....	19
3.5 LED_WLAN#.....	20
3.6 WAKE#.....	21
3.7 USB 2.0.....	22
3.8 USIM Interface.....	23
3.9 UART Interface.....	25
3.10 I2C Interface.....	27
3.11 PCM Interface.....	28
4. RF Specifications	29
4.1 GSM/LTE RF Specifications.....	29
4.2 GSM/LTE Antenna Interface.....	32
4.3 GNSS.....	32
4.3.1 GNSS Antenna interface.....	32
4.3.2 GNSS Technical specification.....	33
5. Electrical Specifications	34
5.1 Absolute Maximum Ratings.....	34
5.2 Recommended Operating Conditions.....	34
5.3 Operating Mode.....	34
5.3.1 Operating Mode.....	34
5.3.2 Low Power consumption mode.....	35
5.4 Current Consumption.....	36
5.5 Electro-Static Discharge.....	37

6. Packaging	38
Appendix	40
I. Coding Schemes and Maximum Net Data Rates over Air Interface	40
II. Related Documents	41
III. Terms and Abbreviations	43
IV. Safety Caution	45

SIMCOM CONFIDENTIAL FILE

Table Index

TABLE 1: SIM7000-PCIE FREQUENCY BANDS	8
TABLE 2: SIM7000-PCIE KEY FEATURES	10
TABLE 3: PCI EXPRESS MINI CARD CONNECTOR PIN DESCRIPTION	13
TABLE 4: RECOMMENDED 3.3V POWER SUPPLY CHARACTERISTICS	16
TABLE 5: PERST# PIN ELECTRONIC CHARACTERISTIC.....	17
TABLE 6: W_DISABLE# PIN STATUS	18
TABLE 7: NETWORK STATUS INDICATION LED STATUS.....	19
TABLE 8: USIM ELECTRONIC CHARACTERISTIC IN 1.8V MODE (USIM_VDD =1.8V)	23
TABLE 9: USIM ELECTRONIC CHARACTERISTIC 3.0V MODE (USIM_VDD =2.95V)	23
TABLE 10: UART ELECTRICAL CHARACTERISTIC	25
TABLE 11: I2C ELECTRICAL CHARACTERISTIC.....	27
TABLE 12: PCM FORMAT	28
TABLE 13: CONDUCTED TRANSMISSION POWER	29
TABLE 14: MAXIMUM POWER REDUCTION (MPR) FOR UE CATEGORY NB1 POWER CLASS 3.....	29
TABLE 15: OPERATING FREQUENCIES.....	30
TABLE 16: E-UTRA OPERATING BANDS.....	30
TABLE 17: CONDUCTED RECEIVE SENSITIVITY	30
TABLE 18: REFERENCE SENSITIVITY FOR HD-FDD UE CATEGORY M1 QPSK $P_{REFSENS}$	31
TABLE 19: CAT-NB1 REFERENCE SENSITIVITY (QPSK).....	31
TABLE 20: ABSOLUTE MAXIMUM RATINGS.....	34
TABLE 21: OPERATING CONDITIONS	34
TABLE 22: OPERATING MODE.....	34
TABLE 23: CURRENT CONSUMPTION (TESTING ENVIRONMENT: VBAT=3.3V).....	36
TABLE 24: ESD CHARACTERISTICS (TEMPERATURE: 25°C, HUMIDITY: 45 %).....	37
TABLE 25: TRAY SIZE.....	39
TABLE 26: SMALL CARTON SIZE.....	39
TABLE 27: BIG CARTON SIZE	39
TABLE 28: CODING SCHEMES AND MAXIMUM NET DATA RATES OVER AIR INTERFACE	40
TABLE 29: RELATED DOCUMENTS	41
TABLE 30: TERMS AND ABBREVIATIONS.....	43
TABLE 31: SAFETY CAUTION.....	45

Figure Index

FIGURE 1: SIM7000-PCIE BLOCK DIAGRAM	10
FIGURE 2: SIM7000-PCIE PIN OUT DIAGRAM	12
FIGURE 3: DIMENSIONS OF SIM7000-PCIE (UNIT: MM)	15
FIGURE 4: POWER SUPPLY REFERENCE CIRCUIT	16
FIGURE 5: PERST# REFERENCE CIRCUIT	17
FIGURE 6: W_DISABLE# REFERENCE CIRCUIT	18
FIGURE 7: LED_WWAN# REFERENCE CIRCUIT	19
FIGURE 8: LED_WLAN# REFERENCE CIRCUIT	20
FIGURE 9: WAKE# BEHAVIOUR	21
FIGURE 10: WAKE# REFERENCE CIRCUIT	21
FIGURE 11: USB REFERENCE CIRCUIT	22
FIGURE 12: USIM INTERFACE REFERENCE CIRCUIT WITH DETECTION FUNCTION	24
FIGURE 13: USIM INTERFACE REFERENCE CIRCUIT	24
FIGURE 14: UART FULL MODEM	25
FIGURE 15: UART NULL MODEM	25
FIGURE 16: REFERENCE CIRCUIT OF LEVEL SHIFT	26
FIGURE 17: I2C REFERENCE CIRCUIT	27
FIGURE 18: RECEIVER INTERFACE CONFIGURATION	28
FIGURE 19: GNSS ANTENNA REFERENCE CIRCUIT	32
FIGURE 20: TRAY PACKAGING	38
FIGURE 21: TRAY DRAWING	38
FIGURE 22: SMALL CARTON DRAWING	39
FIGURE 23: BIG CARTON DRAWING	39

Version History

Date	Version	Description of change	Author
2018-11-08	1.00	Origin	

SIMCOM CONFIDENTIAL FILE

1. Introduction

This document describes the electronic specifications, RF specifications, interfaces, mechanical characteristics and testing results of SIM7000-PCIE. With the help of this document and other related software application notes/user guides, users can understand and use SIM7000-PCIE to design and develop applications quickly.

1.1 Product Outline

Aimed at global market, the SIM7000-PCIE supports LTE CAT-M1, LTE CAT-NB1, GPRS and EDGE. Users can choose the PCIE according to the wireless network configuration. SIM7000-PCIE includes SIM7000A-PCIE, SIM7000C-PCIE, SIM7000E-PCIE, SIM7000JC-PCIE and SIM7000G-PCIE. The supported radio frequency bands are described in the following table.

Table 1: SIM7000-PCIE Frequency Bands

Standard	Frequency	SIM7000-PCIE				
		SIM7000A	SIM7000C	SIM7000E	SIM7000JC	SIM7000G
GPRS	GSM850MHz					✓
	EGSM900MHz		✓	✓		✓
	DCS1800MHz		✓	✓		✓
	PCS1900MHz					✓
LTE-FDD HD-FDD	LTE-FDD B1		✓		✓	✓
	LTE-FDD B2	✓				✓
	LTE-FDD B3		✓	✓	✓	✓
	LTE-FDD B4	✓				✓
	LTE-FDD B5		✓		✓	✓
	LTE-FDD B8		✓	✓	✓	✓
	LTE-FDD B12	✓				✓
	LTE-FDD B13	✓				✓
	LTE-FDD B18				✓	✓
	LTE-FDD B19				✓	✓
	LTE-FDD B20			✓		✓
	LTE-FDD B25					✓
	LTE-FDD B26				✓	✓
	LTE-FDD B28			✓		✓
	LTE-FDD B39					✓
Category	LTE-M1	✓	✓	✓	✓	✓
Category	LTE-NB1		✓	✓	✓	✓
GNSS	GPS	✓	✓	✓	✓	✓
	GLONASS	✓	✓	✓	✓	✓
	BeiDou		✓	✓	✓	✓

1.2 Hardware Interface Overview

SIM7000-PCIE provides various hardware interfaces via Mini PCI Express card connector.

- Power Supply
- PERST#
- W_DISABLE#
- LED_WWAN#
- WAKE#
- USB Interface
- USIM Interface
- UART Interface
- I2C Interface
- PCM Interface
- GPIOs

SIMCOM CONFIDENTIAL FILE

1.3 Hardware Block Diagram

The following figure is SIM7000-PCIE hardware block diagram.

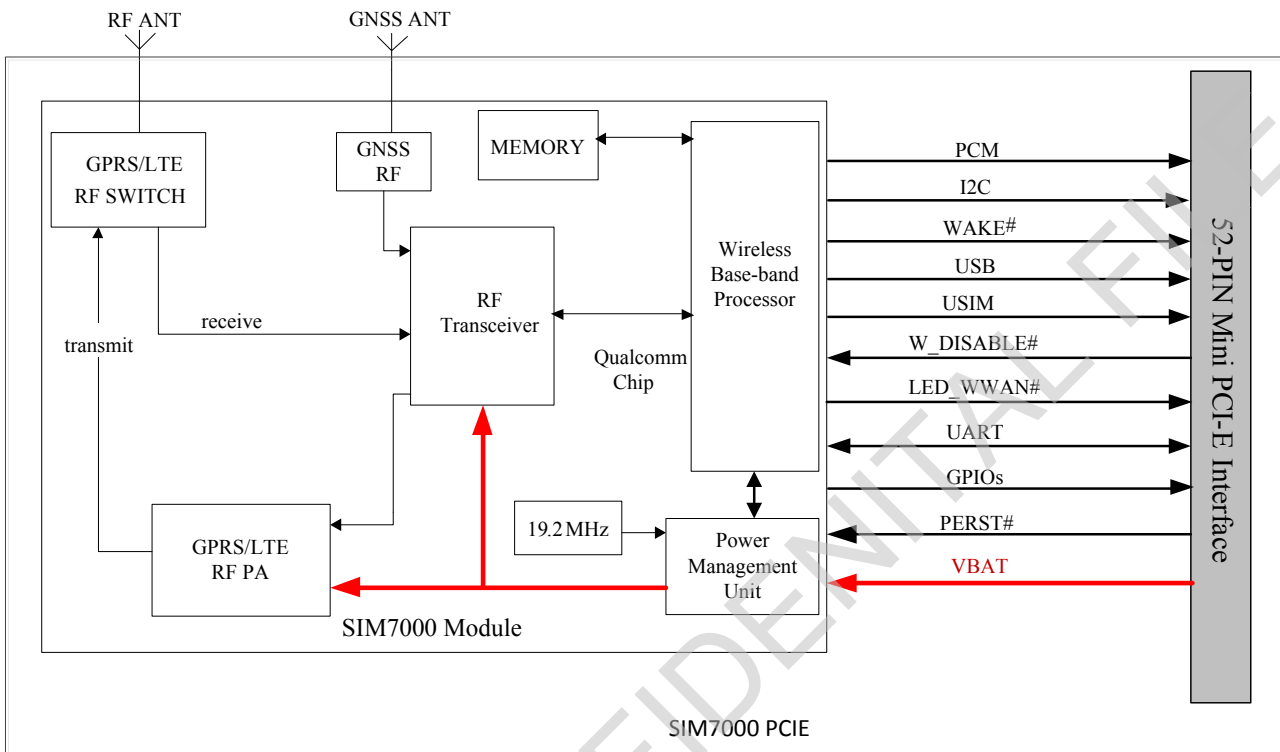

Figure 1: SIM7000-PCIE Block Diagram

1.4 Functional Overview

Table 2: SIM7000-PCIE Key Features

Feature	Implementation
Power supply	Single supply voltage 3.3V~4.3V
Radio frequency bands	Please refer to the table 1
Transmitting power	GPRS power class: --EGSM900: 4 (2W). --DCS1800: 1 (1W). EDGE power class: --EGSM900: E2 (0.5W). --DCS1800: E1 (0.4W). LTE power class: 3 (0.25W).
Data Transmission Throughput	GPRS multi-slot class 12. EDGE multi-slot class 12. LTE CAT M1: 300Kbps (DL). LTE CAT M1: 375Kbps (UL).

	LTE CAT NB1: 34Kbps (DL). LTE CAT NB1: 66Kbps (UL).LTE CAT 4 : 150 Mbps (DL)
Antenna	GPRS/EDGE/LTE main antenna. GNSS antenna.
GNSS	GNSS engine (GPS, GLONASS, BD and Galileo) Protocol: NMEA
SMS	MT, MO, CB, Text and PDU mode SMS storage: USIM card or ME(default)
USIM interface	Support identity card: 1.8V/ 3V
USIM application toolkit	Support SAT class 3, GSM 11.14 Release 98 Support USAT
Phonebook management	Support phonebook types: SM, FD, LD, RC, ON, MC
Audio feature	Support PCM interface. Only support PCM master mode and short frame sync, 16-bit linear data formats.
UART interface	A full modem serial port by default. Baud rate: 300bps to 3686400bps. Default rate is 0bps (auto baud rate). Support auto baud rate, but only limited to 9600, 19200, 38400, 57600 and 115200 bps. Can be used as the AT commands or data stream channel. Support RTS/CTS hardware handshake.
USB	USB 2.0 high speed interface
Firmware upgrade	Firmware upgrade over USB interface
Physical characteristics	Size: 50.80*30*5.2mm Weight: 10g
Temperature range	Normal operation temperature: -30°C to +80°C Extended operation temperature: -40°C to +85°C* Storage temperature -45°C to +90°C

****Note: PCIE is able to make and receive voice calls, data calls, SMS and make GPRS//LTE traffic in -40°C ~+85°C. The performance will reduce slightly from the 3GPP specifications if the temperature is outside of the normal operating temperature and still within the extreme operating temperature.***

2. Package Information

2.1 Pin Out Diagram

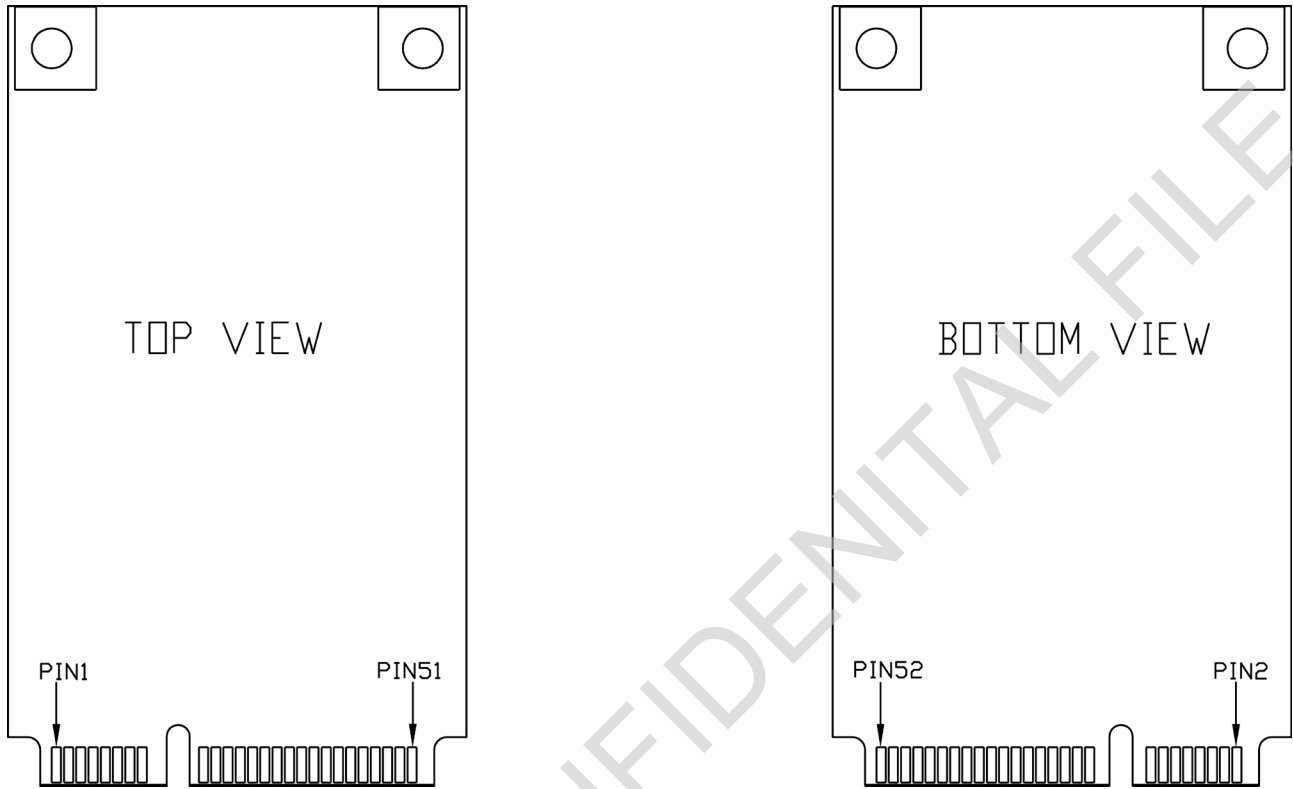

Figure 2: SIM7000-PCIE Pin out Diagram

2.2 PCI Express Mini Card Connector Pin Description

Table 3: PCI Express Mini Card Connector Pin Description

Pin name	Pin number	I/O	Description	Comment
Power supply				
VBAT	2,24,39,41,52	I	Power supply for PCIE	3.8V typical
GND	4,9,15,18,21, 26,27,29,34, 35,37,40,43, 50		Ground	-
Reset interface				
PERST#	22	I	Reset input (Active low)	If unused, keep open.
USB 2.0				
USB_DP	38	I/O	USB 2.0 high speed port for data transfer, voice call, debug and FW download, etc.	If unused, keep open.
USB_DN	36			
USIM card interface				
USIM_VDD	8	O	Power output for USIM card, its output Voltage depends on USIM card type automatically. Its output current is up to 50mA.	-
USIM_DATA	10	I/O	USIM Card data I/O, which has been pulled up via a 100KR resistor to USIM_VDD internally. Do not pull it up or down externally.	-
USIM_CLK	12	O	USIM clock.	Make sure the rise time and fall time of USIM_CLK less than 40ns;
USIM_RST	14	O	USIM Reset.	-
USIM_DET	16	I	USIM card detect.	-
UART interface				
UART_CTS	11	O	Clear to Send	If unused, keep open
UART_RTS	13	I	Request to send	
UART_RXD	17	I	Receive Data	
UART_TXD	19	O	Transmit Data	
UART_RI	25	O	Ring Indicator	
UART_DTR	23	I	DTE get ready	
I2C interface				

I2C_SCL	30	O	I2C clock output	Pulled up inside PCIE, If unused, keep open
I2C_SDA	32	I/O	I2C data input/output	
PCM interface				
PCM_CLK	45	DO	PCM data bit clock.	If unused, keep open.
PCM_SYNC	51	DO	PCM data frame sync signal.	
PCM_DIN	49	DI	PCM data input.	
PCM_DOUT	47	DO	PCM data output.	
Others				
WAKE#	1	I/O	Wake up host	If unused, keep open.
W_DISABLE#	20	I	Low power consumption control Input. Low level effective. When input is low, the PCIE will enter low power mode.	
LED_WWAN#	42	O	Network Status Indication output. OC output.	
LED_WLAN#	44	O	LED Indication output. OC output.	
GPIO0	46	IO	General Purpose Input/output	GPIO power domain is 1.8V. If unused, keep open.
GPIO1	33	IO	General Purpose Input/output	
NC	3,5,7,6,28, 48	--	No connection	Keep open

2.3 Package Dimensions

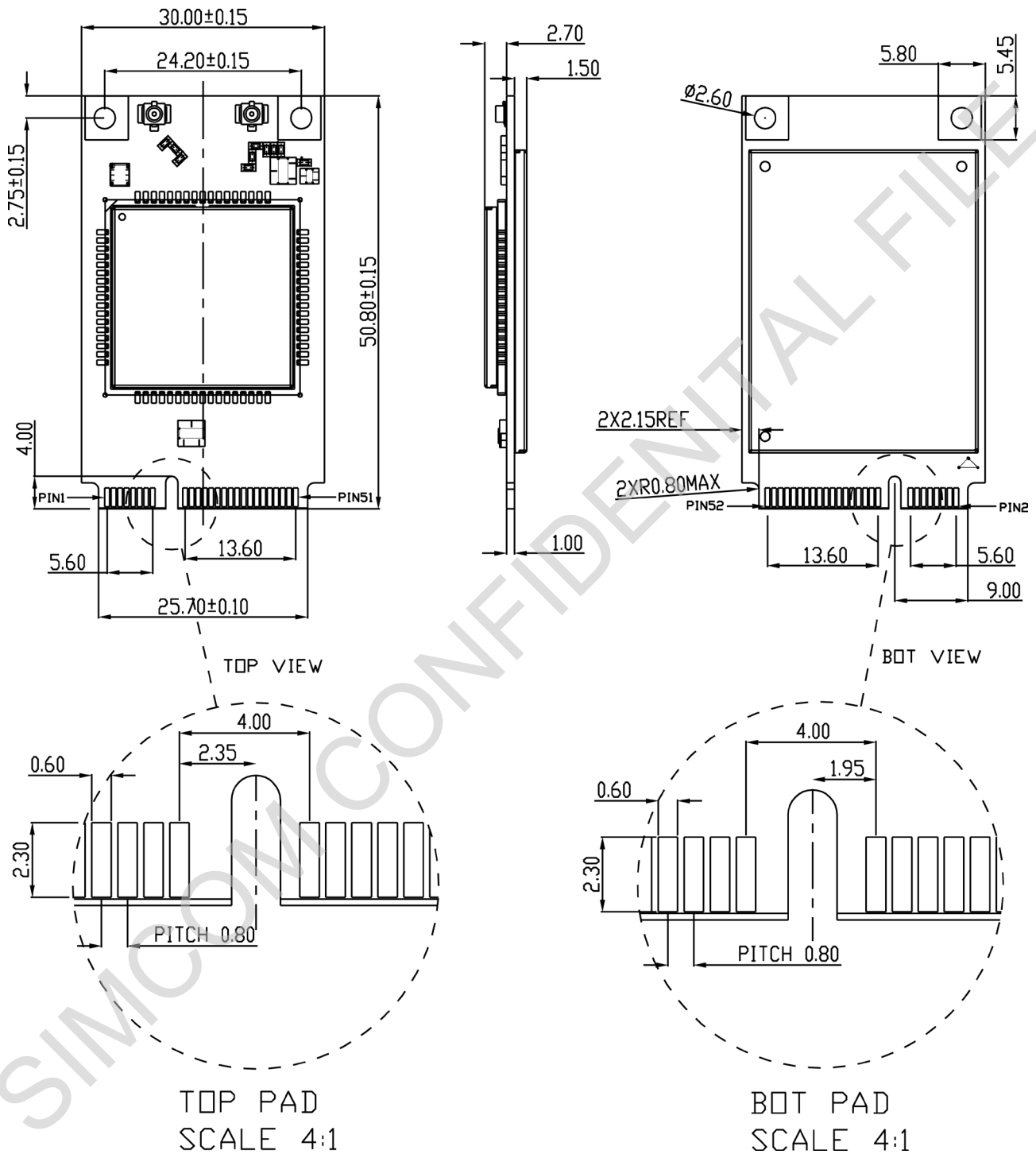

Figure 3: Dimensions of SIM7000-PCIE (Unit: mm)

3. Interface Application

3.1 Power Supply

The power supply pins of SIM7000-PCIE are VBAT

Table 4: Recommended 3.3V Power Supply Characteristics

Symbol	Description	Min.	Typ.	Max.	Unit
VBAT	PCIE power voltage	3.3	3.8	4.3	V
IVBAT(peak)	PCIE power peak current in GSM and EDGE emission mode.	-	2	-	A
	PCIE power peak current in CAT-M1 and NB-IoT emission mode.	-	0.6	-	A

The following figure shows the reference circuit with 5V input and 3.8V output.

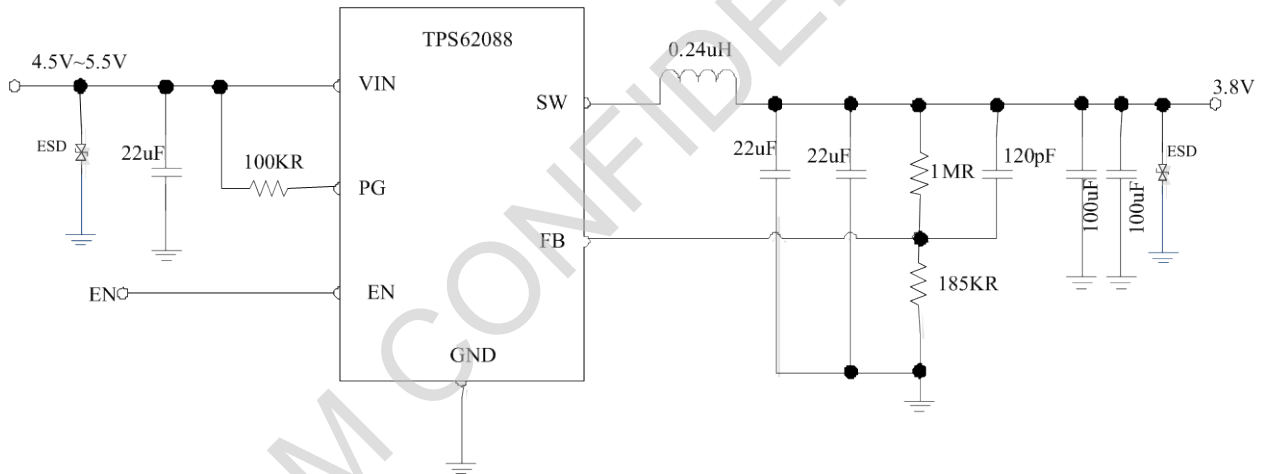

Figure 4: power supply reference circuit

3.2 PERST#

SIM7000-PCIE can be reset by pulling the PERST# pin down to ground.

The PERST# pin has been pulled up with a 47KΩ resistor to 1.8V internally, so there is no need to pull it up externally. It is strongly recommended to put a 100nF capacitor and an ESD protection diode close to the PERST# pin. Please refer to the following figure for the recommended reference circuit.

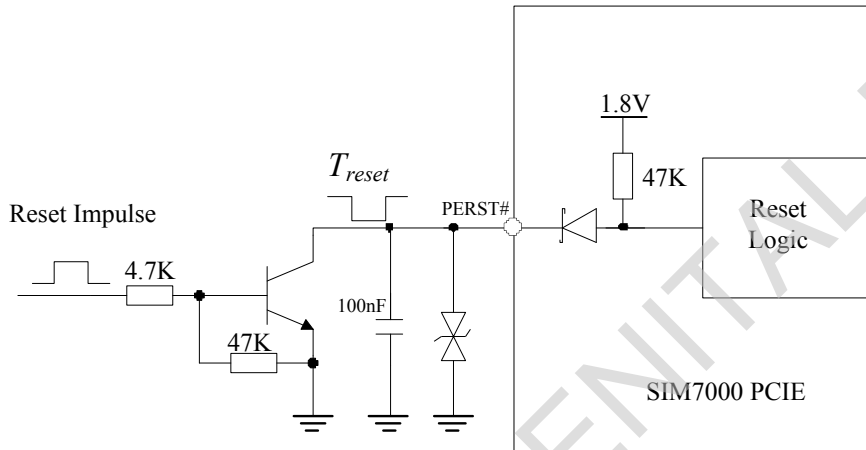

Figure 5: PERST# Reference Circuit

Table 5: PERST# Pin Electronic Characteristic

Symbol	Description	Min.	Typ.	Max.	Unit
Treset	The active low level time impulse on PERST# pin to reset PCIE	225	500	-	ms
VIH	Input high level voltage	1.17	1.8	2.1	V
VIL	Input low level voltage	-0.3	0	0.2	V

3.3 W_DISABLE#

The W_DISABLE# pin can be used to control SIM7000-PCIE to enter or exit low power mode.

Table 6: W_DISABLE# Pin Status

W_DISABLE# status	PCIE operation
Input Low Level	GNSS ANT power supply is closed. USB_VBUS power supply is closed. DTR PIN will be pulled up. PCIE. PCIEs are allowed to enter sleep mode.
Input High Level	GNSS ANT power supply is enabled. USB_VBUS power supply is enabled. DTR PIN will be pulled down. PCIEs will never enter sleep mode.

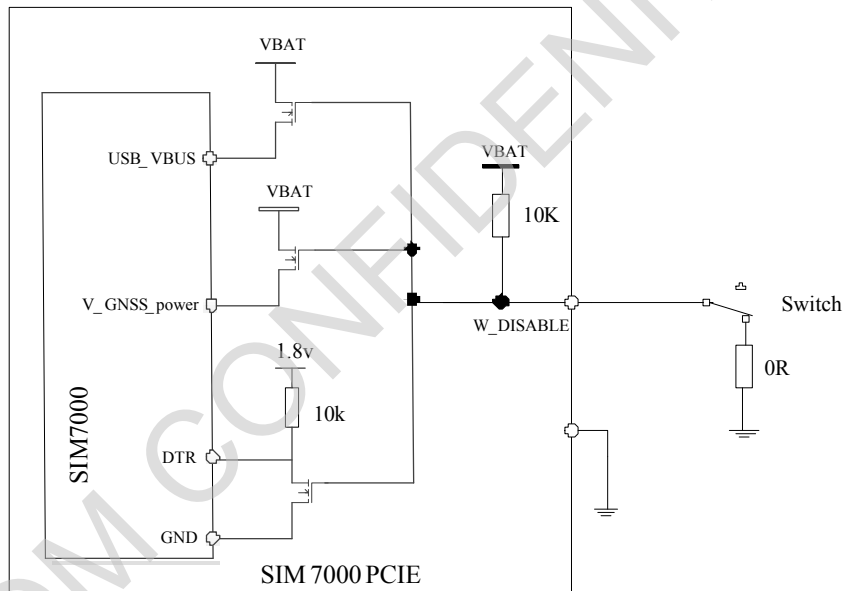

Figure 6: W_DISABLE# Reference Circuit

When the input state of the W_DISABLE# pin is high, SIM7000 PCIE will increase the power consumption of about 28mA.

When the input state of the W_DISABLE# pin is low, SIM7000 PCIE will enter the low-power mode after setting AT command “AT+CSCLK=1”.

3.4 LED_WWAN#

The LED_WWAN# pin can be used to drive a network status indication LED by default. Its status is listed in the following table.

Table 7: Network Status Indication LED Status

NETLIGHT pin status	PCIE status
64ms ON, 800ms OFF	No registered network
64ms ON, 3000ms OFF	Registered network (PS domain registration success)
64ms ON, 300ms OFF	Data transmit (PPP dial-up state and use of data services such as internal TCP/FTP/HTTP)
OFF	Power off

Reference circuit is recommended in the following figure:

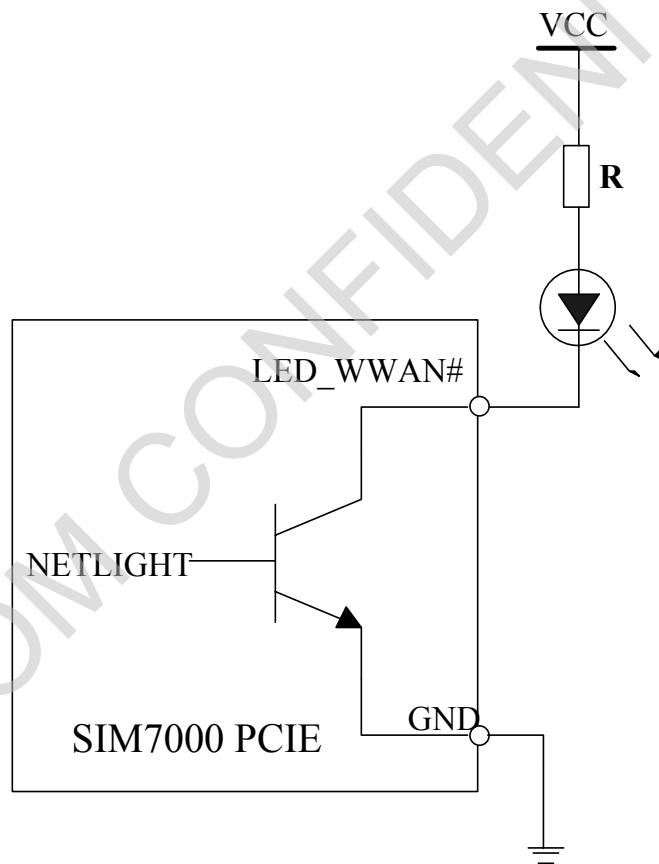

Figure 7: LED_WWAN# Reference Circuit

3.5 LED_WLAN#

The LED_WLAN# pin is open collector gate (OC) output. It can drive external circuits in one direction.

Reference circuit is recommended in the following figure:

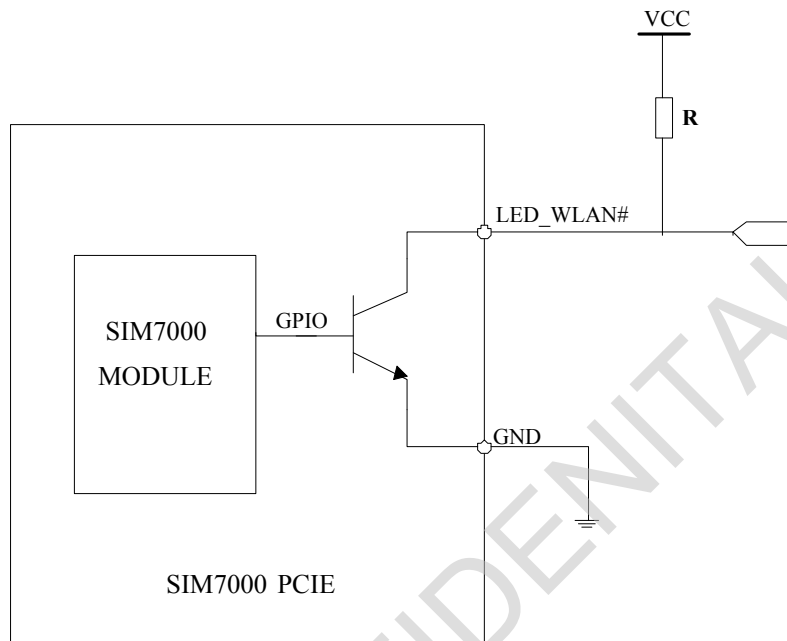

Figure 8: LED_WLAN# Reference Circuit

3.6 WAKE#

The WAKE# pin can be used as an interrupt signal to host. Normally it will keep high logic level until certain condition such as receiving SMS or URC reporting, then WAKE# will change to low logic level to inform the master (client PC).

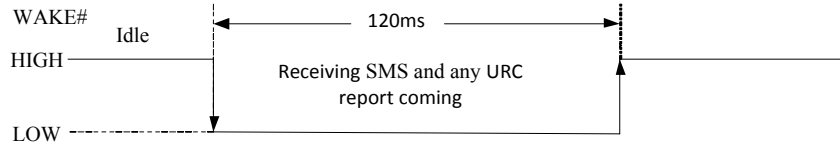

Figure 9: WAKE# behaviour

WAKE# Reference circuit is recommended in the following figure:

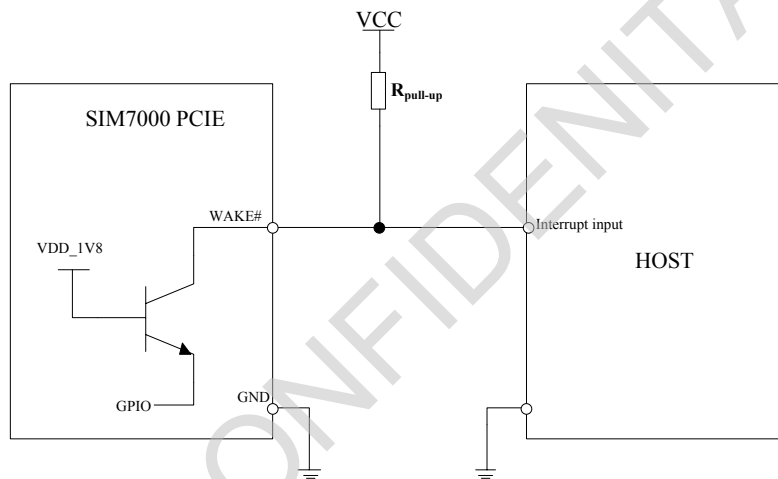

Figure 10: WAKE# Reference Circuit

3.7 USB 2.0

SIM7000-PCIE is compliant with USB 2.0 specification. It supports full-speed and high-speed when acting as a peripheral device.

SIM7000-PCIE USB_VBUS had connected with VBAT power via a MOSFET. Users can control the USB_VBUS power up or power down through W_DISABLE. If W_DISABLE is high level, the USB_VBUS will power up. If W_DISABLE is low level, VBUS will be power down.

SIM7000-PCIE doesn't support USB suspend mode. If USB_VBUS had power supply, SIM7000-PCIE will increase power consumption by about 20mA.

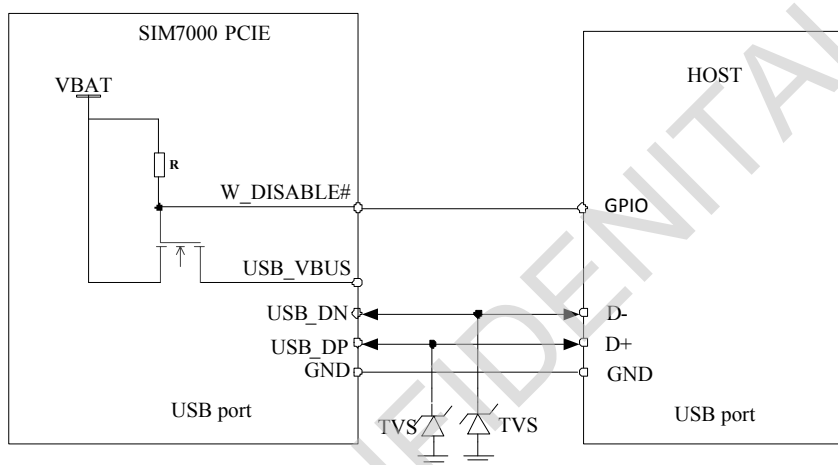

Figure 11: USB Reference Circuit

Because of the high bit rate on USB bus, please pay more attention to the influence of the junction capacitance of the ESD component on USB data lines. Typically, the capacitance should be less than 1pF. It is recommended to use an ESD protection component such as ESD9L5.0ST5G provided by On Semiconductor (www.onsemi.com).

Note:

1. **The USB_DN and USB_DP nets must be traced by 90Ohm \pm 10% differential impedance.**
2. **The USB VBUS of the PCIE is connected to VBAT internally, so there is no need to connect externally.**

3.8 USIM Interface

Both 1.8V and 3.0V USIM card are supported. USIM interface is powered from an internal regulator in the PCIE.

Table 8: USIM Electronic characteristic in 1.8V mode (USIM_VDD =1.8V)

Symbol	Parameter	Min.	Typ.	Max.	Unit
USIM_VDD	LDO power output voltage	1.75	1.8	1.95	V
VIH	High-level input voltage	$0.65 \cdot \text{USIM_VDD}$	-	$\text{USIM_VDD} + 0.3$	V
VIL	Low-level input voltage	-0.3	0	$0.35 \cdot \text{USIM_VDD}$	V
VOH	High-level output voltage	$\text{USIM_VDD} - 0.45$	-	USIM_VDD	V
VOL	Low-level output voltage	0	0	0.45	V

Table 9: USIM Electronic characteristic 3.0V mode (USIM_VDD =2.95V)

Symbol	Parameter	Min.	Typ.	Max.	Unit
USIM_VDD	LDO power output voltage	2.75	2.95	3.05	V
VIH	High-level input voltage	$0.65 \cdot \text{USIM_VDD}$	-	$\text{USIM_VDD} + 0.3$	V
VIL	Low-level input voltage	-0.3	0	$0.25 \cdot \text{USIM_VDD}$	V
VOH	High-level output voltage	$\text{USIM_VDD} - 0.45$	-	USIM_VDD	V
VOL	Low-level output voltage	0	0	0.45	V

The USIM_DET pin is used for detection of the USIM card hot plug. User can select the 8-pin USIM card holder to implement USIM card detection function.

USIM_DET has been pulled up to 1.8V inside PCIE;

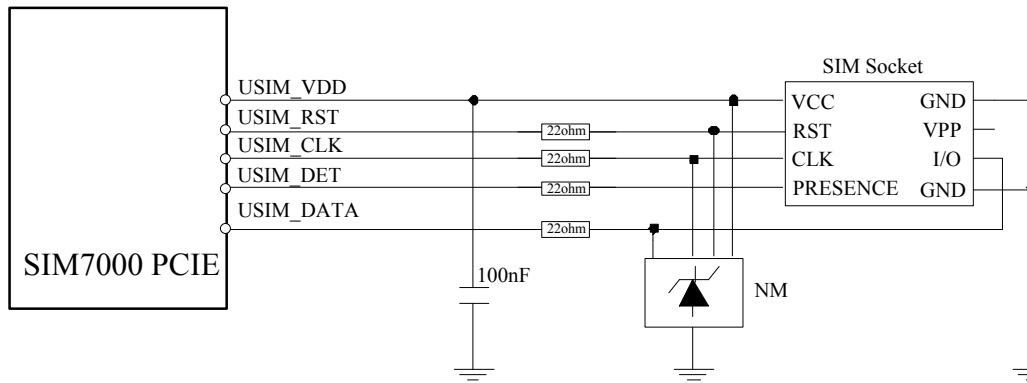

Figure 12: USIM interface reference circuit with detection function

If the USIM card detection function is not used, user can keep the USIM_DET pin open. The reference circuit of 6-pin USIM card holder is illustrated in the following figure.

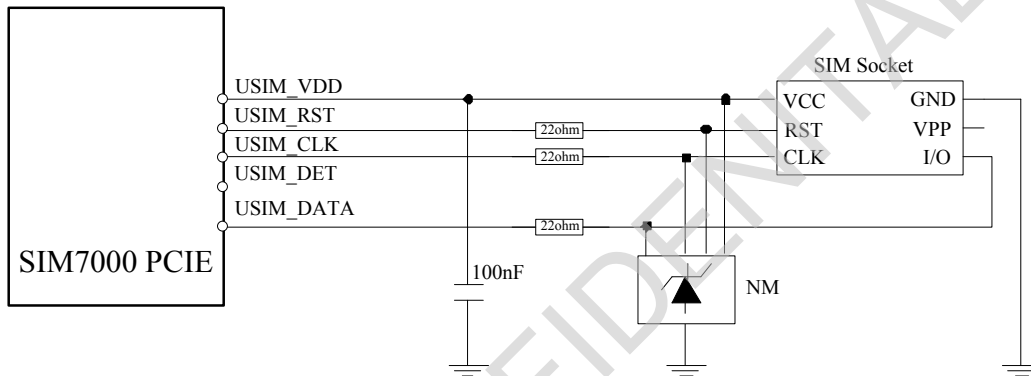

Figure 13: USIM interface reference circuit

Note: USIM_DATA has been pulled up with a 10KΩ resistor to USIM_VDD in PCIE. A 100nF capacitor on USIM_VDD is used to reduce interference.

Note: USIM_CLK is very important signal; customer must make sure the rise time and fall time of USIM_CLK less than 40ns!

3.9 UART Interface

SIM7000-PCIE provides one UART (universal asynchronous serial transmission) port. The PCIE is as the DCE (Data Communication Equipment) and the client PC is as the DTE (Data Terminal Equipment). AT commands are entered and serial communication is performed through UART interface.

The application circuit is in the following figures.

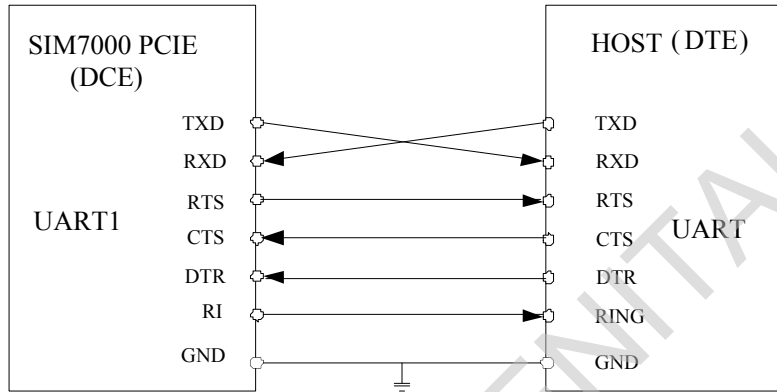

Figure 14: UART Full modem

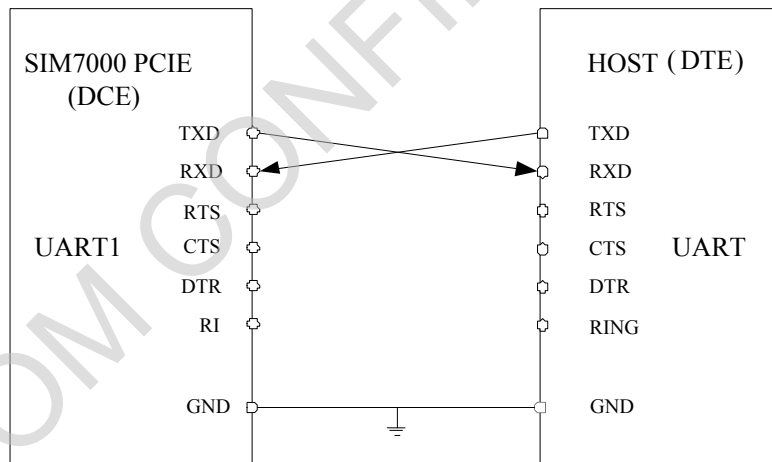

Figure 15: UART Null modem

Table 10: UART Electrical Characteristic

Symbol	Parameter	Min	Typ	Max	Unit
VIH	High-level input voltage	1.17	1.8	2.1	V
VIL	Low-level input voltage	-0.3	0	0.63	V
VOH	High-level output voltage	1.35	1.8	1.8	V
VOL	Low-level output voltage	0	0	0.45	V

The SIM7000-PCIE UART is 1.8V interface. A voltage level converter should be used if user's application is equipped with a 3.3V UART interface. A voltage level converter TXB0108RGYR provided by Texas Instruments is recommended. The reference design of the TXB0108RGYR is in the following figures.

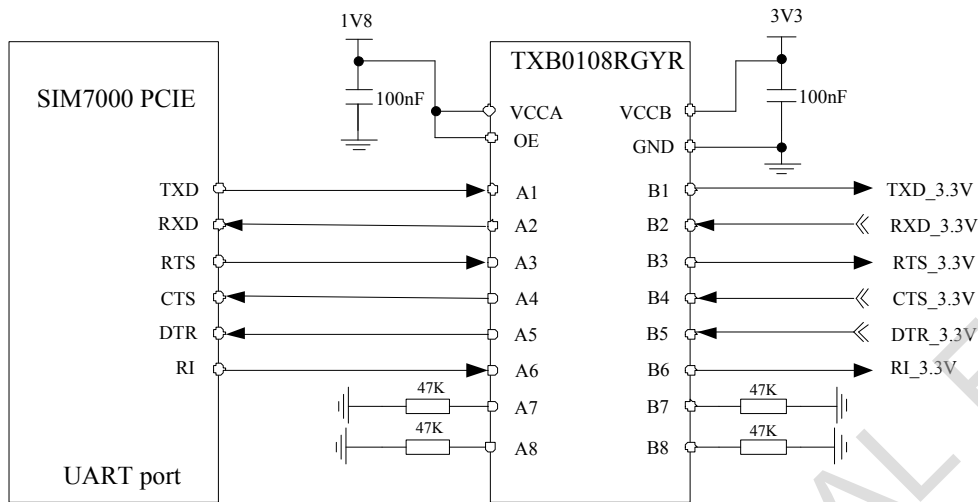

Figure 16: Reference circuit of level shift

To comply with RS-232-C protocol, the RS-232-C level shifter chip should be used to connect SIM7000-PCIE to the RS-232-C interface. In this connection, the TTL level and RS-232-C level are converted mutually. SIMCom recommends that user uses the SP3238ECA chip with a full modem. For more information please refers to the RS-232-C chip datasheet.

Note: SIM7000-PCIE supports the following baud rate: 300, 600, 1200, 2400, 4800, 9600, 19200, 38400, 57600, 115200, 230400, 460800, 921600, 2000000, 3200000, 3686400bps. Default baud rate is 115200bps.

3.10 I2C Interface

SIM7000-PCIE provides I2C interface compatible with I2C specification, version 5.0, with clock rate up to 400 kbps. Its operation voltage is 1.8V.

Note: Since the I2C is connected to the audio codec chip on board, the users should choose the I2C device whose address is not the same with the audio codec (0x34). If the audio codec chip is not mounted on board, users could ignore this.

The following figure shows the I2C bus reference design.

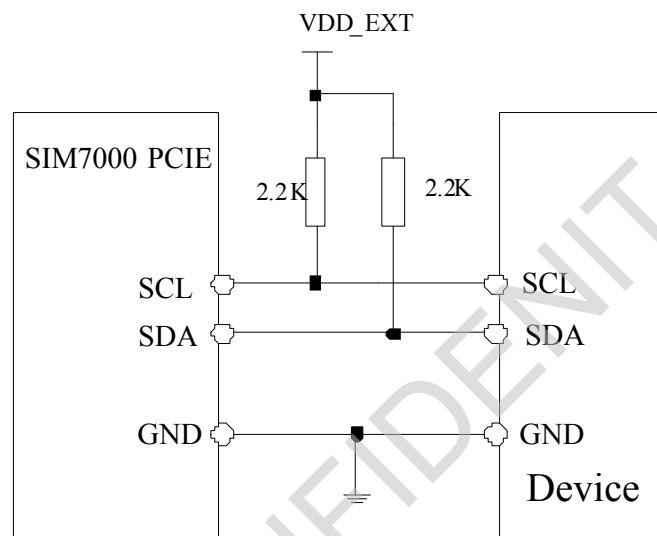

Figure 17: I2C Reference Circuit

Note: For more details about I2C AT commands please refer to document [1].

Table 11: I2C Electrical Characteristic

Symbol	Parameter	Min	Typ	Max	Unit
VIH	High-level input voltage	1.17	1.8	2.1	V
VIL	Low-level input voltage	-0.3	0	0.63	V
VOH	High-level output voltage	1.35	1.8	1.8	V
VOL	Low-level output voltage	0	0	0.45	V

3.11 PCM Interface

SIM7000-PCIE provides a PCM interface for external codec, which can be used in master mode with short sync and 16 bits linear format.

Table 12: PCM format

Characteristics	Specification
Line Interface Format	Linear(Fixed)
Data length	16bits(Fixed)
PCM Clock/Sync Source	Master Mode(Fixed)
PCM Clock Rate	2048 KHz (Fixed)
PCM Sync Format	Short sync(Fixed)
Data Ordering	MSB

The following figure shows the external codec reference design.

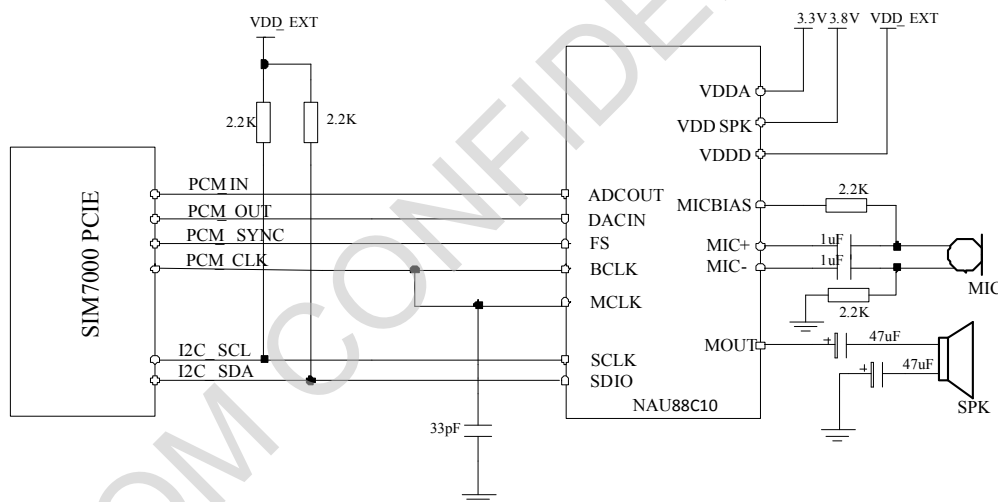

Figure 18: Receiver interface configuration

4. RF Specifications

4.1 GSM/LTE RF Specifications

Table 13: Conducted transmission power

Frequency	Power	Min.
EGSM900	33dBm \pm 2dB	5dBm \pm 5dB
GSM850	33dBm \pm 2dB	5dBm \pm 5dB
DCS1800	30dBm \pm 2dB	0dBm \pm 5dB
PCS1900	30dBm \pm 2dB	0dBm \pm 5dB
LTE-FDD B1	23dBm \pm 2.7dB	<-40dBm
LTE-FDD B2	23dBm \pm 2.7dB	<-40dBm
LTE-FDD B3	23dBm \pm 2.7dB	<-40dBm
LTE-FDD B4	23dBm \pm 2.7dB	<-40dBm
LTE-FDD B5	23dBm \pm 2.7dB	<-40dBm
LTE-FDD B8	23dBm \pm 2.7dB	<-40dBm
LTE-FDD B12	23dBm \pm 2.7dB	<-40dBm
LTE-FDD B13	23dBm \pm 2.7dB	<-40dBm
LTE-FDD B17	23dBm \pm 2.7dB	<-40dBm
LTE-FDD B18	23dBm \pm 2.7dB	<-40dBm
LTE-FDD B19	23dBm \pm 2.7dB	<-40dBm
LTE-FDD B20	23dBm \pm 2.7dB	<-40dBm
LTE-FDD B26	23dBm \pm 2.7dB	<-40dBm
LTE-FDD B28	23dBm \pm 2.7dB	<-40dBm
LTE-FDD B39	23dBm \pm 2.7dB	<-40dBm

** Note: The max power is tested result for 1RB in CAT-M1 and single-tone in CAT-NB1. MPR for CAT-M1 please refer to 6.2.3EA.5 part for 3GPP. Multi-tone test results please refer to part 6.2.3F.3 for CAT-NB1.*

Table 14: Maximum Power Reduction (MPR) for UE category NB1 Power Class 3

Modulation	QPSK		
	Tone positions for 3 Tones allocation	0-2	3-5 and 6-8
MPR	≤ 0.5 dB	0 dB	≤ 0.5 dB
Tone positions for 6 Tones allocation	0-5 and 6-11		
MPR	≤ 1 dB	≤ 1 dB	
Tone positions for 12 Tones allocation	0-11		
MPR	≤ 2 dB		

Table 15: Operating frequencies

Frequency	Receiving	Transmission
EGSM900	925~960MHz	880~915 MHz
GSM850	869.2~893.8	824.2~848.8
DCS1800	1805~1880 MHz	1710~1785 MHz
PCS1900	1805.2~1879.8	1710.2~1784.8
GPS L1 BAND	1574.4 ~1576.44 MHz	-
GLONASS	1598 ~1606 MHz	-
BD	1559 ~1563 MHz	
LTE BAND	Refers to Table 21	

Table 16: E-UTRA operating bands

E-UTRA	UL Freq.	DL Freq.	Duplex Mode
1	1920 ~1980 MHz	2110 ~2170 MHz	HD-FDD
3	1710 ~1785 MHz	1805 ~1880 MHz	HD-FDD
5	824 ~849 MHz	869 ~894 MHz	HD-FDD
6	830 ~840 MHz	875 ~885 MHz	HD-FDD
8	880 ~915 MHz	925 ~960 MHz	HD-FDD
12	699 ~716 MHz	729 ~746 MHz	HD-FDD
13	777 ~787 MHz	746 ~756 MHz	HD-FDD
18	815 ~830 MHz	860 ~875 MHz	HD-FDD
19	830 ~845 MHz	875 ~890 MHz	HD-FDD
20	832 ~862 MHz	791 ~821 MHz	HD-FDD
26	814 ~849 MHz	859 ~894 MHz	HD-FDD
28	703 ~748 MHz	758 ~803 MHz	HD-FDD
39	1880 ~1920 MHz	1880 ~1920 MHz	TDD

Table 17: Conducted receive sensitivity

Frequency	Receive sensitivity(Typical)	Receive sensitivity(MAX)
EGSM900/GSM850	< -109dBm	3GPP
DCS1800/DCS1900	< -109dBm	3GPP
LTE FDD/TDD	Refers to Table 23	

Table 18: Reference sensitivity for HD-FDD UE category M1 QPSK $P_{REFSENS}$

E-UTRA Band	REFSENS (dBm)	Duplex Mode
1	-103	HD-FDD
2	-101	HD-FDD
3	-100	HD-FDD
4	-103	HD-FDD
5	-101.5	HD-FDD
8	-100.5	HD-FDD
12	-100	HD-FDD
13	-100	HD-FDD
17	-100	HD-FDD
18	-103 ⁴	HD-FDD
19	-103	HD-FDD
20	-100.5	HD-FDD
26	-101	HD-FDD
28	-101.5	HD-FDD
39	-103	HD-FDD

Table 19: CAT-NB1 Reference sensitivity (QPSK)

Operating band	REFSENS (dBm) 3GPP Request	REFSENS Typical(dBm)	REFSENS Typical Repeated(dBm)
1, 2, 3, 4,5, 8, 12, 13, 17, 18, 19, 20, 26, 28	-108.2	-114	-129

4.2 GSM/LTE Antenna Interface

Users should connect antennas to SIM7000's antenna connector. SIMCom recommends that the antennas used should meet the following requirements:

- Make sure the efficiency of LTE main ANT more than 40%
- Keep the decoupling of LTE main ANT to WLAN ANT more than 15dB
- Keep the decoupling of LTE main ANT to GNSS ANT more than 30dB

Note: The decoupling value can be provided by ANT adventure. More details can refer to the document [22].

4.3 GNSS

SIM7000 merges GNSS (GPS/GLONASS/BD) satellite and network information to provide a high-availability solution that offers industry-leading accuracy and performance. This solution performs well, even in very challenging environmental conditions where conventional GNSS receivers fail, and provides a platform to enable wireless operators to address both location-based services and emergency mandates.

4.3.1 GNSS Antenna interface

The power supply of GNSS active antenna is integrated in SIM7000 PCIE, the power supply range is from 2.5V to 3.3V. And the current consumption of GNSS active antennas is about 7ma.

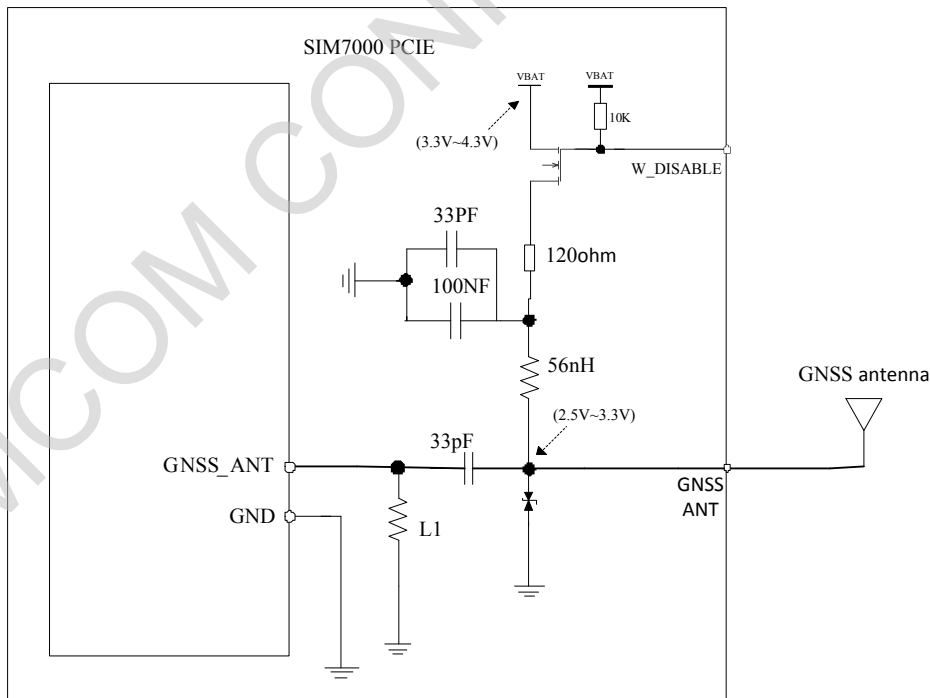

Figure 19: GNSS antenna Reference Circuit

If it is passive antenna, customers can connect the antenna directly.

4.3.2 GNSS Technical specification

- Tracking sensitivity: -162 dBm (GPS) /-157 dBm (GLONASS) /TBD (BD)
- Cold-start sensitivity: -148 dBm
- Accuracy (Open Sky): 2.5m (CEP50)
- TTFF (Open Sky) : Hot start <1s, Cold start<35s
- Receiver Type: 16-channel, C/A Code
- GPS L1 Frequency: 1575.42±1.023MHz
- GLONASS: 1597.5~1605.8 MHz
- BD: 1559.05~1563.14 MHz
- Update rate: Default 1 Hz
- GNSS data format: NMEA-0183
- GNSS Current consumption : 30mA (GSM/LTE Sleep, in total on VBAT pins)
- GNSS antenna: Passive/Active antenna

SIMCOM CONFIDENTIAL FILE

5. Electrical Specifications

5.1 Absolute Maximum Ratings

The absolute maximum ratings are described by the following table. PCIE may be damaged beyond these ratings.

Table 20: Absolute maximum ratings

Symbol	Parameter	Min	Type	Max	Unit
VBAT	VBAT input voltage	-0.3	-	4.5	V
VIO	Voltage at digital pins (1.8V digital I/O) *	-0.3	-	2.1	V

**Note: These parameters are for digital interface pins, such as I2C, UART, and GPIO.*

5.2 Recommended Operating Conditions

Please refer to the follow table for recommended operating conditions.

Table 21: Operating Conditions

Symbol	Parameter	Min	Type	Max	Unit
VBAT	3.8V Input voltage	3.3	3.8	4.3	V
VIO	Voltage at digital pins (1.8V digital I/O)	0	1.8	1.95	V
TOPER	Operating temperature	-40	+25	+85	°C
TSTG	Storage temperature	-45	+25	+90	°C

5.3 Operating Mode

5.3.1 Operating Mode

The table below summarizes the various operating modes of SIM7000-PCIE.

Table 22: Operating Mode

Mode	Function
Normal operation	GPRS/EDGE/LTE Sleep In this case, the current consumption of PCIE will be reduced to the minimal level and the PCIE can still receive paging message and SMS.
	GPRS/EDGE /LTE Idle Software is active. PCIE is registered to the network, and the PCIE is ready to communicate.

	GPRS/EDGE/LTE Standby	PCIE is ready for data transmission, but no data is currently sent or received. In this case, power consumption depends on network settings.
	GPRS/EDGE/LTE Data transmission	There is data transmission in progress. In this case, power consumption is related to network settings (e.g. power control level); uplink/downlink data rates, etc.
	Minimum functionality mode	AT command “AT+CFUN” can be used to set the PCIE to a minimum functionality mode without removing the power supply. In this mode, the RF part of the PCIE will not work or the USIM card will not be accessible, or both RF part and USIM card will be closed, and the serial port and USB port are still accessible. The power consumption in this mode is lower than normal mode.
	Power ON	PCIE will turn on automatically after VBAT power supply.
	Power off	Users could cut off the VBAT to power off PCIE.

5.3.2 Low Power consumption mode

SIM7000-PCIE has two low power consumption modes: minimum functionality mode and sleep mode. In which PCIE will achieve lower power consumption for power saving.

Because SIM7000 PCIE PWRKEY pin is pulled down permanently to GND via a 0R resistor, SIM7000 PCIE does not support PSM mode.

5.3.2.1 Sleep mode

In sleep mode, the current consumption of PCIE will be reduced to the minimal level, and PCIE can still receive paging message and SMS.

Several hardware and software conditions must be satisfied together in order to let SIM7000-PCIE enter into sleep mode:

- UART condition
- USB condition
- Software condition

Note: Before designing, pay attention to how to realize sleeping/waking function and refer to Document [22] for more details.

5.3.2.2 Minimum functionality mode

Minimum functionality mode ceases a majority function of PCIE, thus minimizing the power consumption. This mode is set by the AT command which provides a choice of the functionality levels.

- AT+CFUN=0: Minimum functionality
- AT+CFUN=1: Full functionality (Default)
- AT+CFUN=4: Disable RF function of the PCIE (Flight mode)

If SIM7000-PCIE has been set to minimum functionality mode, the PCIE will firstly enter sleep mode, then the RF function and USIM card function will be closed. In this case, the serial port is still accessible, but RF function or USIM card will be unavailable. When SIM7000-PCIE is in minimum functionality or flight mode, it can return to full functionality by the AT command “AT+CFUN=1”.

5.4 Current Consumption

The current consumption is listed in the table below.

Table 23: Current Consumption (Testing Environment: VBAT=3.3V)

GNSS	
GNSS supply current (AT+CFUN=0, without USB connection)	@ -140dBm, Tracking Typical: 30mA
GSM sleep/idle mode	
GSM/GPRS supply current (GNSS off, without USB connection)	Sleep mode@ BS_PA_MFRMS=2 Typical: 2mA Idle mode@ BS_PA_MFRMS=2 Typical: 15mA
LTE sleep/idle mode	
LTE supply current (GNSS off, without USB connection)	Sleep mode Typical: 2mA Idle mode Typical: 15mA
GPRS	
EGSM900(1 Rx, 4 Tx)	@power level #5 Typical: 563mA
DCS1800(1 Rx, 4 Tx)	@power level #0 Typical: 358mA
EGSM900(3Rx, 2 Tx)	@power level #5 Typical: 432mA
DCS1800(3Rx, 2 Tx)	@power level #0 Typical: 266mA
EDGE	
EGSM900(1 Rx, 4 Tx)	@power level #8 Typical: 522mA
DCS1800(1 Rx, 4 Tx)	@power level #2 Typical: 367mA
EGSM900(3Rx, 2 Tx)	@power level #8 Typical: 398mA
DCS1800(3Rx, 2 Tx)	@power level #2 Typical: 225mA
LTE data	
LTE-FDD B1	@23dbm Typical: TBD @10dbm Typical: TBD @0dbm Typical: TBD
LTE-FDD B2	@23dbm Typical: TBD @10dbm Typical: TBD @0dbm Typical: TBD
LTE-FDD B3	@23dbm Typical: 216mA @10dbm Typical: 164mA @0dbm Typical: 161 mA
LTE-FDD B4	@23dbm Typical: TBD @10dbm Typical: TBD @0dbm Typical: TBD
LTE-FDD B5	@23dbm Typical: 232mA @10dbm Typical: 167mA @0dbm Typical: 158mA
LTE-FDD B8	@23dbm Typical: 227mA @10dbm Typical: 166mA @0dbm Typical: 158mA

LTE-FDD B12	@23dbm Typical: TBD @10dbm Typical: TBD @0dbm Typical: TBD
LTE-FDD B13	@23dbm Typical: TBD @10dbm Typical: TBD @0dbm Typical: TBD
LTE-FDD B18	@23dbm Typical: TBD @10dbm Typical: TBD @0dbm Typical: TBD
LTE-FDD B19	@23dbm Typical: TBD @10dbm Typical: TBD @0dbm Typical: TBD
LTE-FDD B20	@23dbm Typical: 234mA @10dbm Typical: 167mA @0dbm Typical: 158 mA
LTE-FDD B26	@23dbm Typical: TBD @10dbm Typical: TBD @0dbm Typical: TBD
LTE-FDD B28	@23dbm Typical: 241mA @10dbm Typical: 168mA @0dbm Typical: 159mA

Note: In the table above the current consumption value is the typical one of the PCIE tested in the laboratory. In the mass production stage, there may be some difference.

5.5 Electro-Static Discharge

SIM7000-PCIE is an ESD sensitive component, so more attention should be paid to the procedure of handling and packaging. The ESD test results are shown in the following table.

Table 24: ESD characteristics (Temperature: 25°C, Humidity: 45 %)

Part	Contact discharge	Air discharge
VBAT,GND	+/-6K	+/-12K
Antenna port	+/-5K	+/-10K
USB	+/-4K	+/-8K
UART	+/-3K	+/-6K
Other PADS	+/-3K	+/-6K

6. Packaging

SIM7000 PCIE supports tray packaging.

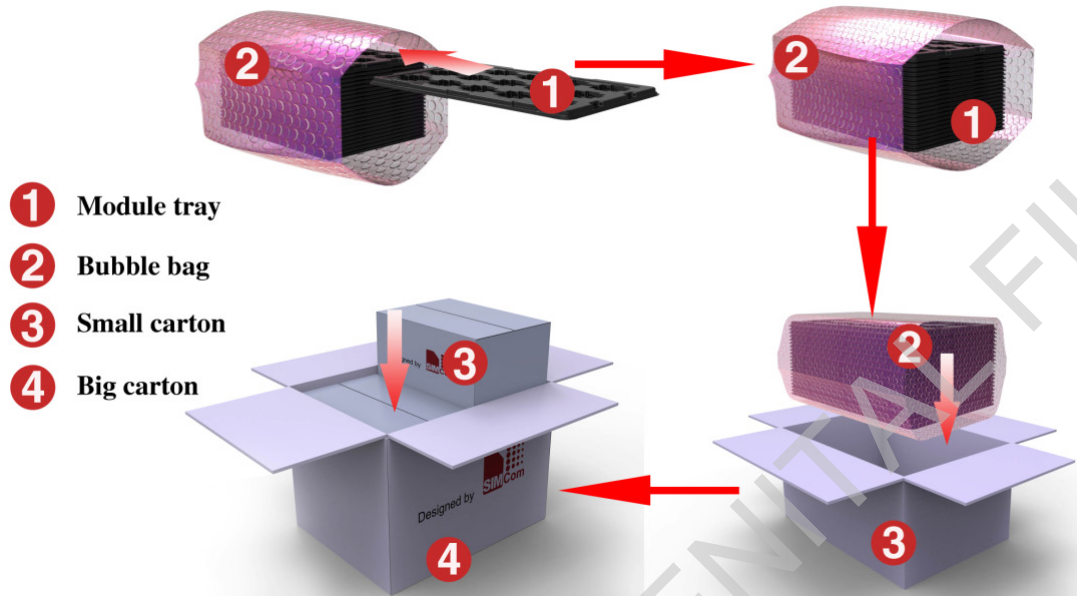

Figure 20: Tray packaging

SIM7000 PCIE tray drawing:

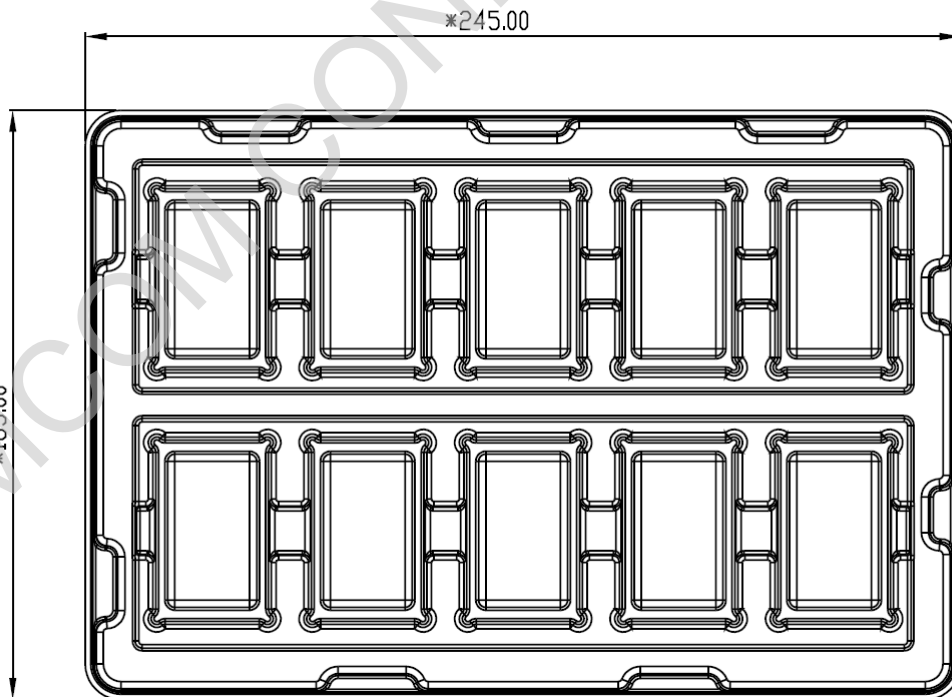

Figure 21: Tray drawing

Table 25: Tray size

Length ($\pm 3\text{mm}$)	Width ($\pm 3\text{mm}$)	Number
245.0	165.0	10

Small carton drawing:

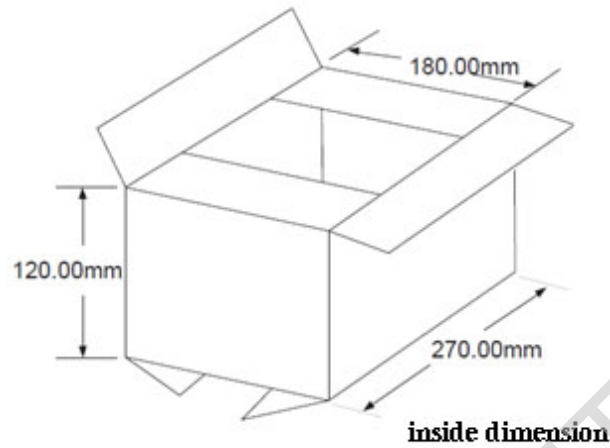

Figure 22: Small carton drawing

Table 26: Small Carton size

Length($\pm 10\text{mm}$)	Width ($\pm 10\text{mm}$)	Height ($\pm 10\text{mm}$)	Number
270	180	120	10*10=100

Big carton drawing:

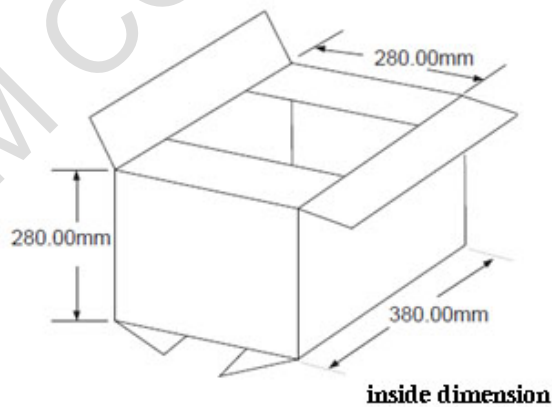

Figure 23: Big carton drawing

Table 27: Big Carton size

Length($\pm 10\text{mm}$)	Width ($\pm 10\text{mm}$)	Height ($\pm 10\text{mm}$)	Number
380	280	280	100*4=400

Appendix

I. Coding Schemes and Maximum Net Data Rates over Air Interface

Table 28: Coding Schemes and Maximum Net Data Rates over Air Interface

Multislot definition(GPRS/EDGE)			
Slot class	DL slot number	UL slot number	Active slot number
1	1	1	2
2	2	1	3
3	2	2	3
4	3	1	4
5	2	2	4
6	3	2	4
7	3	3	4
8	4	1	5
9	3	2	5
10	4	2	5
11	4	3	5
12	4	4	5
GPRS coding scheme	Max data rata (4 slots)		Modulation type
CS 1 = 9.05 kb/s / time slot	36.2 kb/s		GMSK
CS 2 = 13.4 kb/s / time slot	53.6 kb/s		GMSK
CS 3 = 15.6 kb/s / time slot	62.4 kb/s		GMSK
CS 4 = 21.4 kb/s / time slot	85.6 kb/s		GMSK
EDGE coding scheme	Max data rata (4 slots)		Modulation type
MCS 1 = 8.8 kb/s/ time slot	35.2 kb/s		GMSK
MCS 2 = 11.2 kb/s/ time slot	44.8 kb/s		GMSK
MCS 3 = 14.8 kb/s/ time slot	59.2 kb/s		GMSK
MCS 4 = 17.6 kb/s/ time slot	70.4 kb/s		GMSK
MCS 5 = 22.4 kb/s/ time slot	89.6 kb/s		8PSK
MCS 6 = 29.6 kb/s/ time slot	118.4 kb/s		8PSK
MCS 7 = 44.8 kb/s/ time slot	179.2 kb/s		8PSK
MCS 8 = 54.4 kb/s/ time slot	217.6 kb/s		8PSK
MCS 9 = 59.2 kb/s/ time slot	236.8 kb/s		8PSK
LTE-FDD device category (Uplink)	Max data rate (peak)		Modulation type
Category NB	DL/UL:~60kbps/~50kbps		QPSK
Category M1	DL/UL:1Mbps		QPSK/16QAM

II. Related Documents

Table 29: Related Documents

NO.	Title	Description
[1]	SIM7000 Series AT Command Manual V1.xx	AT Command Manual
[2]	GSM 07.07	Digital cellular telecommunications (Phase 2+); AT command set for GSM Mobile Equipment (ME)
[3]	GSM 07.10	Support GSM 07.10 multiplexing protocol
[4]	GSM 07.05	Digital cellular telecommunications (Phase 2+); Use of Data Terminal Equipment – Data Circuit terminating Equipment (DTE – DCE) interface for Short Message Service (SMS) and Cell Broadcast Service (CBS)
[5]	GSM 11.14	Digital cellular telecommunications system (Phase 2+); Specification of the SIM Application Toolkit for the Subscriber Identity Module – Mobile Equipment (SIM – ME) interface
[6]	GSM 11.11	Digital cellular telecommunications system (Phase 2+); Specification of the Subscriber Identity Module – Mobile Equipment (SIM – ME) interface
[7]	GSM 03.38	Digital cellular telecommunications system (Phase 2+); Alphabets and language-specific information
[8]	GSM 11.10	Digital cellular telecommunications system (Phase 2); Mobile Station (MS) conformance specification; Part 1: Conformance specification
[9]	3GPP TS 51.010-1	Digital cellular telecommunications system (Release 5); Mobile Station (MS) conformance specification
[10]	3GPP TS 34.124	Electromagnetic Compatibility (EMC) for mobile terminals and ancillary equipment.
[11]	3GPP TS 34.121	Electromagnetic Compatibility (EMC) for mobile terminals and ancillary equipment.
[12]	3GPP TS 34.123-1	Technical Specification Group Radio Access Network; Terminal conformance specification; Radio transmission and reception (FDD)
[13]	3GPP TS 34.123-3	User Equipment (UE) conformance specification; Part 3: Abstract Test Suites.
[14]	EN 301 908-02 V2.2.1	Electromagnetic compatibility and Radio spectrum Matters (ERM); Base Stations (BS) and User Equipment (UE) for IMT-2000. Third Generation cellular networks; Part 2: Harmonized EN for IMT-2000, CDMA Direct Spread (UTRA FDD) (UE) covering essential requirements of article 3.2 of the R&TTE Directive
[15]	EN 301 489-24 V1.2.1	Electromagnetic compatibility and Radio Spectrum Matters

		(ERM); Electromagnetic Compatibility (EMC) standard for radio equipment and services; Part 24: Specific conditions for IMT-2000 CDMA Direct Spread (UTRA) for Mobile and portable (UE) radio and ancillary equipment
[16]	IEC/EN60950-1(2001)	Safety of information technology equipment (2000)
[17]	3GPP TS 51.010-1	Digital cellular telecommunications system (Release 5); Mobile Station (MS) conformance specification
[18]	2002/95/EC	Directive of the European Parliament and of the Council of 27 January 2003 on the restriction of the use of certain hazardous substances in electrical and electronic equipment (RoHS)
[19]	Module secondary-SMT-UGD V1.xx	Module secondary SMT Guidelines
[20]	SIM7000 Series UART Application Note_V1.xx	This document describes how to use UART interface of SIMCom modules.
[21]	ETSI EN 301 908-13 (ETSI TS 136521-1 R13.4.0)	IMT cellular networks; Harmonized EN covering the essential requirements of article 3.2 of the R&TTE Directive; Part 13
[22]	ANTENNA DESIGN GUIDELINES FOR MULTI-ANTENNA SYSTEM V1 01	Design notice for multi-antenna.

III. Terms and Abbreviations

Table 30: Terms and Abbreviations







Abbreviation	Description
ADC	Analog-to-Digital Converter
ARP	Antenna Reference Point
BER	Bit Error Rate
BTS	Base Transceiver Station
CS	Coding Scheme
CSD	Circuit Switched Data
CTS	Clear to Send
DAC	Digital-to-Analog Converter
DRX	Discontinuous Reception
DSP	Digital Signal Processor
DTE	Data Terminal Equipment (typically computer, terminal, printer)
DTR	Data Terminal Ready
DTX	Discontinuous Transmission
EFR	Enhanced Full Rate
EGSM	Enhanced GSM
EMC	Electromagnetic Compatibility
ESD	Electrostatic Discharge
ETS	European Telecommunication Standard
EVDO	Evolution Data Only
FCC	Federal Communications Commission (U.S.)
FD	SIM fix dialing phonebook
FDMA	Frequency Division Multiple Access
FR	Full Rate
GMSK	Gaussian Minimum Shift Keying
GPRS	General Packet Radio Service
GSM	Global Standard for Mobile Communications
HR	Half Rate
HSPA	High Speed Packet Access
I2C	Inter-Integrated Circuit
IMEI	International Mobile Equipment Identity
LTE	Long Term Evolution
MO	Mobile Originated
MS	Mobile Station (GSM engine), also referred to as TE
MT	Mobile Terminated
PAP	Password Authentication Protocol
PBCCH	Packet Switched Broadcast Control Channel
PCB	Printed Circuit Board
PCS	Personal Communication System, also referred to as GSM 1900
RF	Radio Frequency
RMS	Root Mean Square (value)
RTC	Real Time Clock
SIM	Subscriber Identification PCIE
SMS	Short Message Service
SPI	serial peripheral interface

SMPS	Switched-mode power supply
TDMA	Time Division Multiple Access
TE	Terminal Equipment, also referred to as DTE
TX	Transmit Direction
UART	Universal Asynchronous Receiver & Transmitter
VSWR	Voltage Standing Wave Ratio
SM	SIM phonebook
NC	Not connect
EDGE	Enhanced data rates for GSM evolution
HSDPA	High Speed Downlink Packet Access
HSUPA	High Speed Uplink Packet Access
ZIF	Zero intermediate frequency
WCDMA	Wideband Code Division Multiple Access
VCTCXO	Voltage control temperature-compensated crystal oscillator
USIM	Universal subscriber identity PCIE
UMTS	Universal mobile telecommunications system
UART	Universal asynchronous receiver transmitter

SIMCOM CONFIDENTIAL FILE

IV. Safety Caution

Table 31: Safety caution

Marks	Requirements
	When in a hospital or other health care facility, observe the restrictions about the use of mobiles. Switch the cellular terminal or mobile off, medical equipment may be sensitive to not operate normally for RF energy interference.
	Switch off the cellular terminal or mobile before boarding an aircraft. Make sure it is switched off. The operation of wireless appliances in an aircraft is forbidden to prevent interference with communication systems. Forget to think much of these instructions may lead to the flight safety or offend against local legal action, or both.
	Do not operate the cellular terminal or mobile in the presence of flammable gases or fumes. Switch off the cellular terminal when you are near petrol stations, fuel depots, chemical plants or where blasting operations are in progress. Operation of any electrical equipment in potentially explosive atmospheres can constitute a safety hazard.
	Your cellular terminal or mobile receives and transmits radio frequency energy while switched on. RF interference can occur if it is used close to TV sets, radios, computers or other electric equipment.
	Road safety comes first! Do not use a hand-held cellular terminal or mobile when driving a vehicle, unless it is securely mounted in a holder for hands free operation. Before making a call with a hand-held terminal or mobile, park the vehicle.
	GSM cellular terminals or mobiles operate over radio frequency signals and cellular networks and cannot be guaranteed to connect in all conditions, for example no mobile fee or a invalid SIM card. While you are in this condition and need emergent help, please remember using emergency calls. In order to make or receive calls, the cellular terminal or mobile must be switched on and in a service area with adequate cellular signal strength. Some networks do not allow for emergency call if certain network services or phone features are in use (e.g. lock functions, fixed dialing etc.). You may have to deactivate those features before you can make an emergency call. Also, some networks require that a valid SIM card be properly inserted in the cellular terminal or mobile.

Contact us:

Shanghai SIMCom Wireless Solutions Ltd.

Add: SIM Technology Building, No.633, Jinzhong Road, Changning District, Shanghai, P.R. China 200335

Tel: +86 21 3157 5200

URL: www.simcomm2m.com

SIMCOM CONFIDENTIAL FILE