

CH03-GB - 3FF MICRO SIM CARD CONNECTOR SMT, PUSH PUSH TYPE, WITH SWITCH, 6 OR 8 CONTACTS

FEATURES

- GENERAL CHARACTERISTICS**  
 DIMENSIONS: 15.75L x 17.17W x 1.50H mm  
 WEIGHT: APPROX. 0.4g  
 CONTACT PRINCIPLE: FRICTION TECHNOLOGY  
 DURABILITY: 1,500 CYCLES MIN.
- MECHANICAL CHARACTERISTICS**  
 INSULATION MATERIAL: THERMOPLASTIC, UL 94V-0  
 CONTACT MATERIAL: PHOSPHOR BRONZE, GOLD PLATED  
 CD SWITCH: PHOSPHOR BRONZE, GOLD PLATED  
 SHELL MATERIAL: STAINLESS STEEL, GOLD PLATED ON SMT AREA  
 SWITCH TYPE: BLADE, NORMALLY CLOSE
- ELECTRICAL CHARACTERISTICS**  
 NUMBER OF CONTACTS: 6, 8 PINS (OPTIONAL)  
 CONTACT RESISTANCE (CONTACTS): 50m OHMS TYP. 100m OHMS MAX.  
 CONTACT RESISTANCE (SWITCH): 300m OHMS MAX.  
 INSULATION RESISTANCE: >1000M OHMS / 500V DC  
 DIELECTRIC WITHSTANDING VOLTAGE: 500V AC RMS, 1 MINUTE  
 VOLTAGE RATING: 50V MAX.  
 CURRENT RATING: 1A MAX., 10uA MIN.
- SOLDERABILITY**  
 WAVE: NOT APPLICABLE  
 IR REFLOW: 250°C, 5 SEC. MAX.  
 MANUAL SOLDERING: 370°C, 3 SEC. MAX.
- ENVIRONMENTAL CHARACTERISTICS**  
 OPERATING TEMPERATURE: -40°C ~ +85°C  
 OPERATING HUMIDITY: 10% ~ 95% RH  
 STORAGE TEMPERATURE: -40°C ~ +85°C  
 STORAGE HUMIDITY: 10% ~ 95% RH

NOTES:  
 1. ACCEPTABLE SIM CARD SIZE SHOULD MEET GSM 11.11 SPECIFICATION REQUIREMENT.

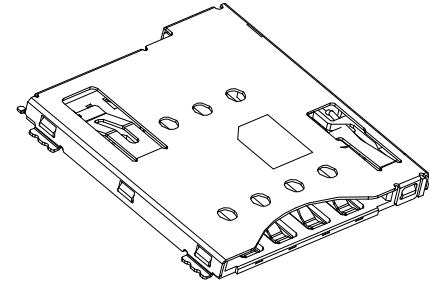
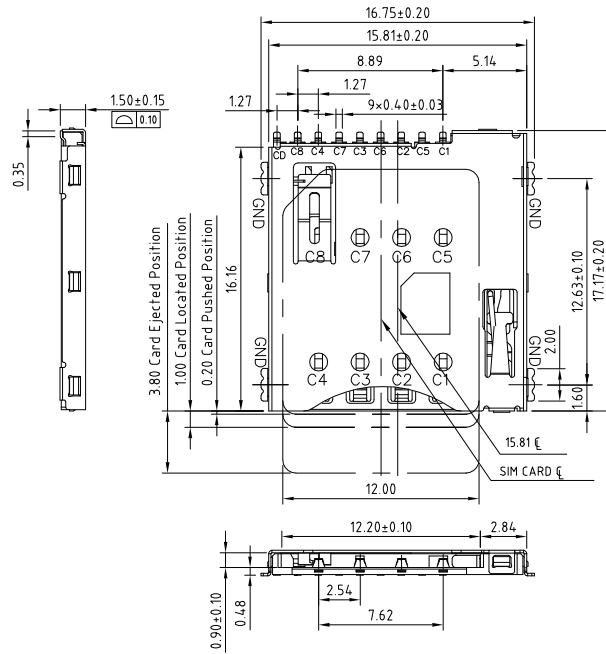
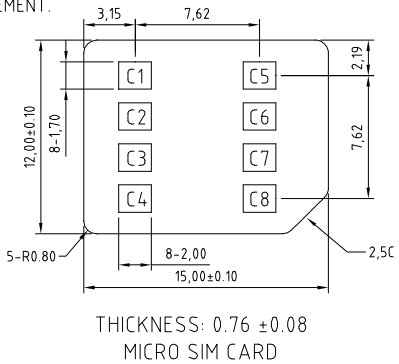

Switch Operation Diagram

Electric Function	Defect Switch
Without Card	Closed
Card Inserted	Open

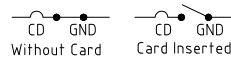

HOW TO ORDER

CH03 - GBXX0 - ABR

NO. OF CONTACTS  
 06 OR 08

PACKAGING OPTIONS  
 R = TAPE & REEL (1000PCS/REEL)

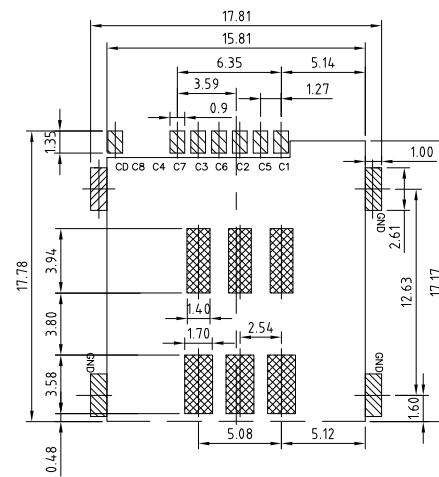

BOARD PAD NO WIRING AREA (TOLERANCES: ±0.05)  
 RECOMMENDED PCB LAYOUT (6 PINS)

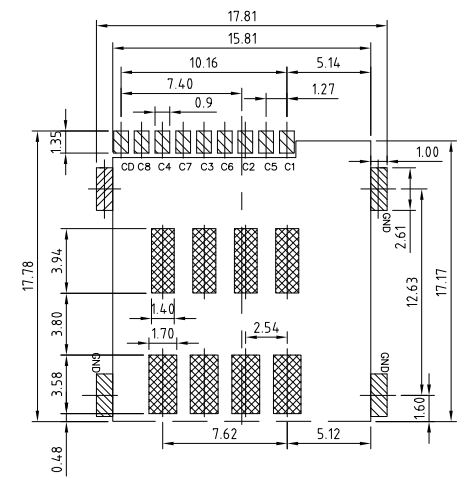

BOARD PAD NO WIRING AREA (TOLERANCES: ±0.05)  
 RECOMMENDED PCB LAYOUT (8 PINS)

REV. DATE & DRN 10 18/07/14 - NYW RELEASE 11 11/03/19 - NYW CHANGE METAL SHELL DESIGN AMEND PCB LAYOUT	Scale: 3:1	THIRD ANGLE	Unstated Tolerances: XX ± 0.15	Material: SEE NOTE
	Drawn: NYW			
	App'd: XXXX	Title: SIM CARD ACCEPTOR		NOT TO SCALE
	Date: 11 MAR. '19	Revision: 1.1		Unit: mm

www.gradconn.com

THIS DRAWING IS CONFIDENTIAL AND MUST NOT BE COPIED OR DISCLOSED WITHOUT WRITTEN CONSENT

Type: CH03-GB
CH03-GB
Drawing Number:
Sheet 1 of 1
Drawing © E and O E

CH03-GB - PACKAGING DRAWING

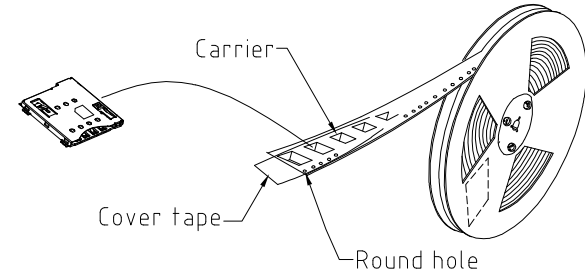
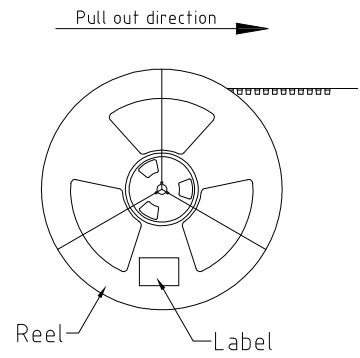
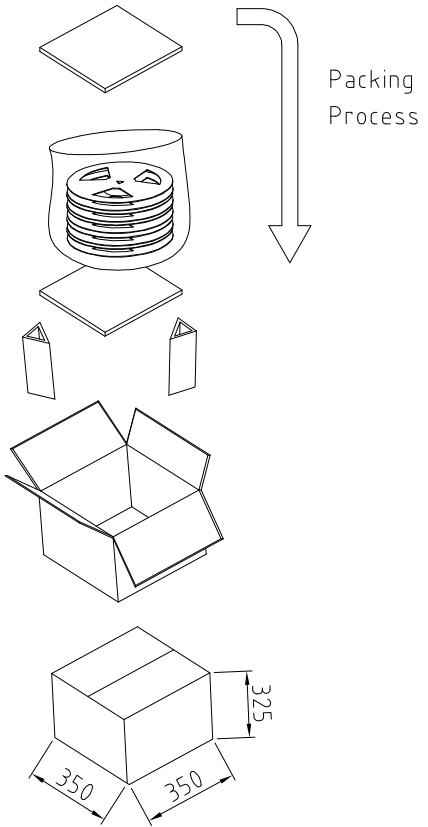
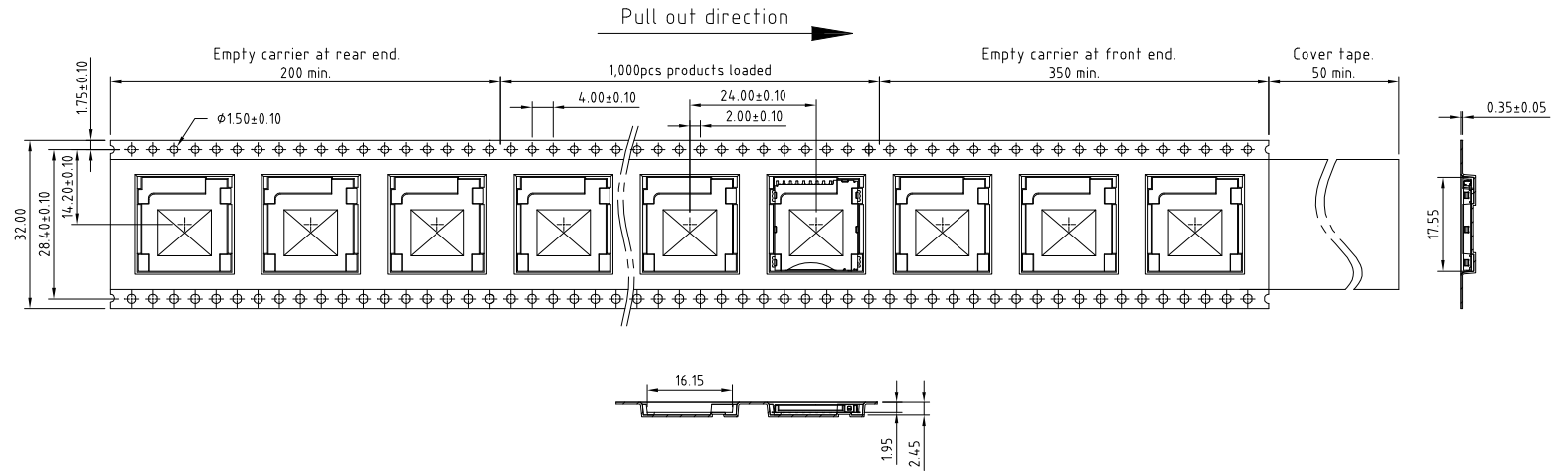

- NOTES:
1. REEL DIA.: 33CM.
  2. 1,000PCS PER REEL, GROSS WEIGHT: 0.85KG.
  3. 8 REELS PER FULL CARTON, GROSS WEIGHT: 7.7KG.

REV. DATE & DRN  
1.0 05/08/14 - NYW RELEASE

	THIRD ANGLE	Unstated .X .XX .XXX X.°	Tolerances: ±0.15 ±0.10 ±0.05 ±1.5°	Material SEE NOTE
Drawn: NYW				NOT TO SCALE
App'd: XXX	Title: PACKAGING			Unit: mm
Date: 5 AUG. '14	Revision: 1.0			

www.gradconn.com

© THIS DRAWING IS CONFIDENTIAL AND MUST NOT BE COPIED OR DISCLOSED WITHOUT WRITTEN CONSENT

Type: CH03-GB
CH03-GB
Drawing Number:
Sheet 1 of 1
Drawing © E and O E