

Front VIEW

Back VIEW

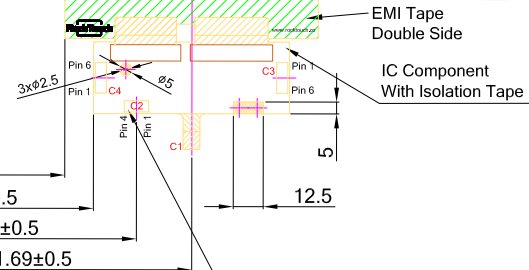
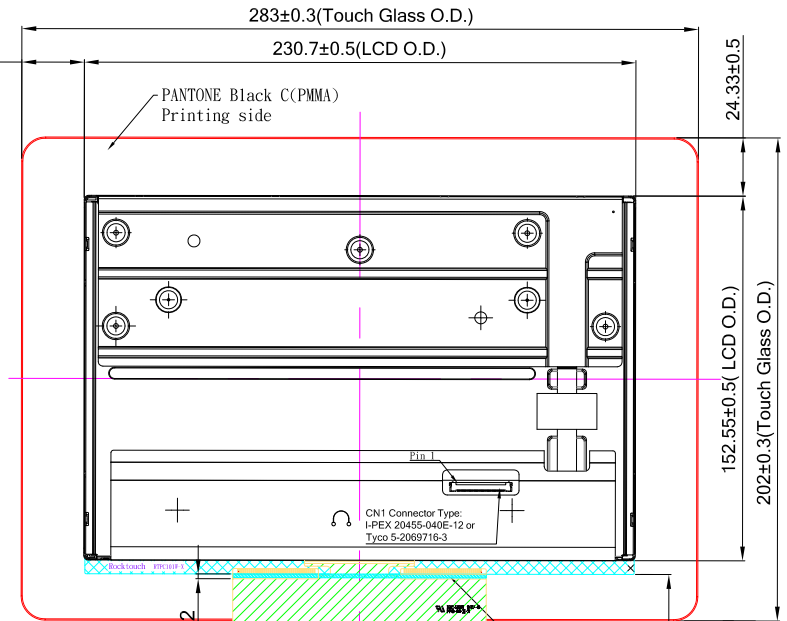
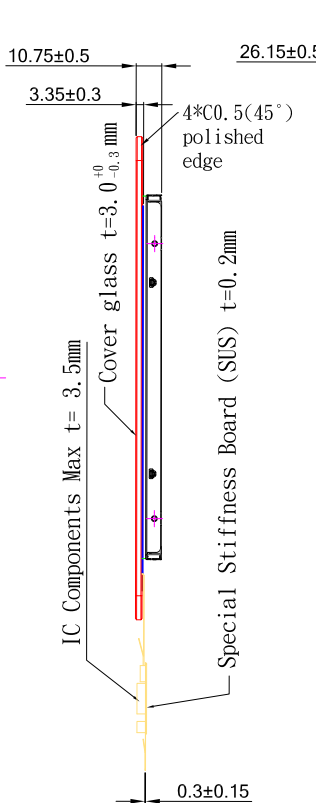
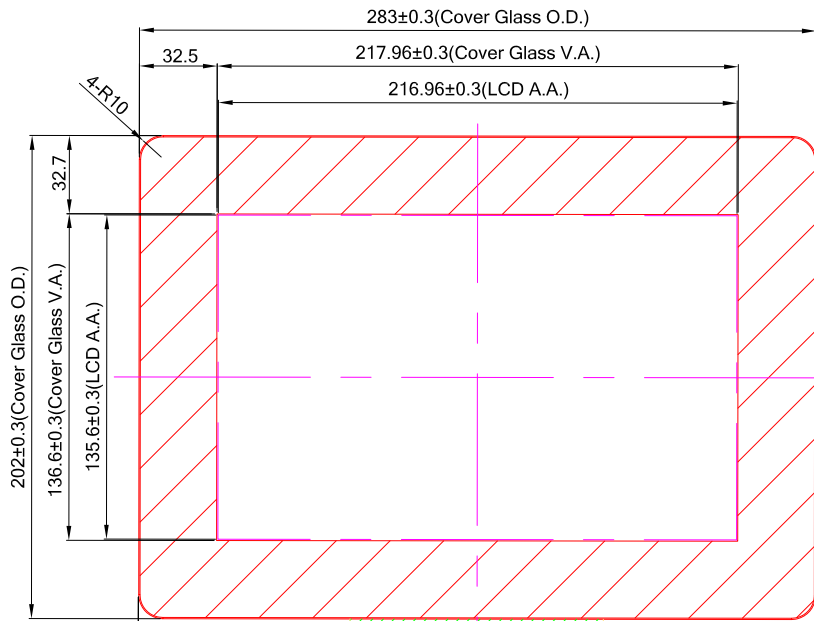

USB Connector Type :
P125L-04SMT-01(HF)
or EQUIVALENT

| C1:USB Interface | | C2:Pin Define for USB 4 pin | |
|------------------|-----|-----------------------------|-----|
| Pin 01 | GND | Pin 01 | GND |
| Pin 02 | D- | Pin 02 | D- |
| Pin 03 | D+ | Pin 03 | D+ |
| Pin 04 | VDD | Pin 04 | VDD |
| Pin 05 | NC | | |
| Pin 06 | RST | | |

| CN1 Pin Define | | | | | | | |
|----------------|-------------|-----|--------|-----|---------|-----|----------|
| PIN | SYMBOL | PIN | SYMBOL | PIN | SYMBOL | PIN | SYMBOL |
| 1 | VCCS | 11 | Rxin1- | 21 | Rxin3+ | 31 | LED_GND |
| 2 | VCCS | 12 | Rxin1+ | 22 | VSS | 32 | LED_GND |
| 3 | VCCS | 13 | VSS | 23 | NC | 33 | LED_GND |
| 4 | Data format | 14 | Rxin2- | 24 | NC | 34 | NC |
| 5 | NC | 15 | Rxin2+ | 25 | VSS | 35 | NC |
| 6 | NC | 16 | VSS | 26 | VSS | 36 | LED_VCCS |
| 7 | NC | 17 | RxCLK- | 27 | LED_PWM | 37 | LED_VCCS |
| 8 | Rxin0- | 18 | RxCLK+ | 28 | LED_EN | 38 | LED_VCCS |
| 9 | Rxin0+ | 19 | VSS | 29 | LED_GND | 39 | LED_VCCS |
| 10 | VSS | 20 | Rxin3- | 30 | LED_GND | 40 | LED_VCCS |

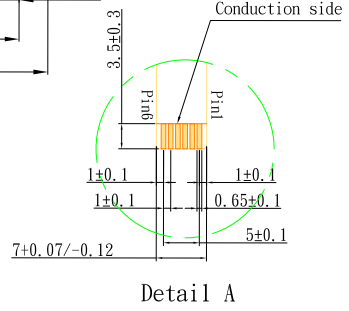
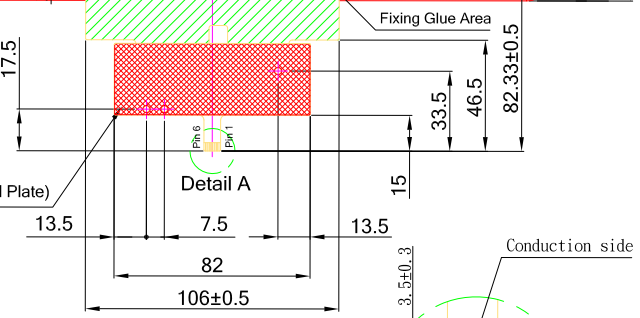

- Note:
1. Tolerance: ±0.3mm
 2. Touch finger input or special conductive pen
 3. Touch Surface Hardness: 6H (Semi Tempered Glass)
 4. Touch Transmittance: >85% (JIS-K7105)
 5. Touch Surface Treatment: None
 6. If customer put a front cover all around need use at least 2mm thick gasket between touch and metal frame
 7. USB max ripple acceptable is 50mV, in other case touch will not work correctly
 8. Referring to the integration guide to avoid any integration noise issue
 9. LCD model : FLC-101HML2000SA1#00
 10. Touch model : Rocktouch RTPC101WF1-R1-30BP1-C
 11. Assembly Solution : DSA

| | | | | | | | |
|-------------------|----------|-------------------|--------|-------------------|------|-------------|--|
| Customer Approval | | Part Number # REV | | FLD-101HML20PCSA4 | | #00 | |
| Date | Drawn By | Date | Person | Description | | | |
| Company | | | | | | | |
| Name | | | | | | | |
| Signature | Date | Design By | Date | Check By | Date | Approved By | |
| First Drawing | | 20200908 | | Matt | | | |