

The position of 2 original cell welding points on the cell are not fixed.

\* $\varnothing 12.28^{+0.1}_{-0.3}$   
(Cell diameter & including overlaps tape thickness)

Pre-tinned 3-5 $\mu$ m thick over 2.5 $\pm$ 1mm length on both sides.

No expose allowed on Negative surface & cover with kapton tape

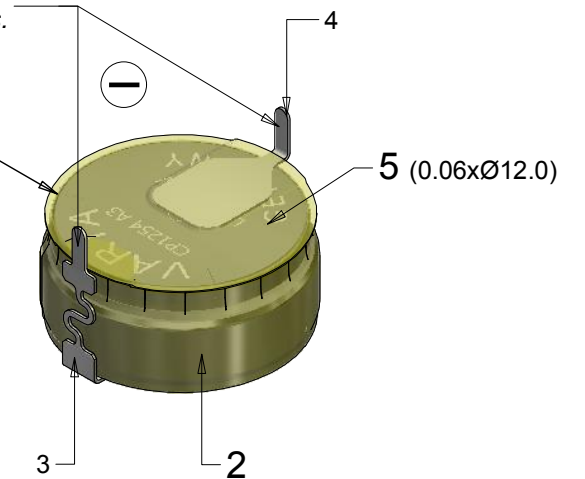

View without kapton tapes

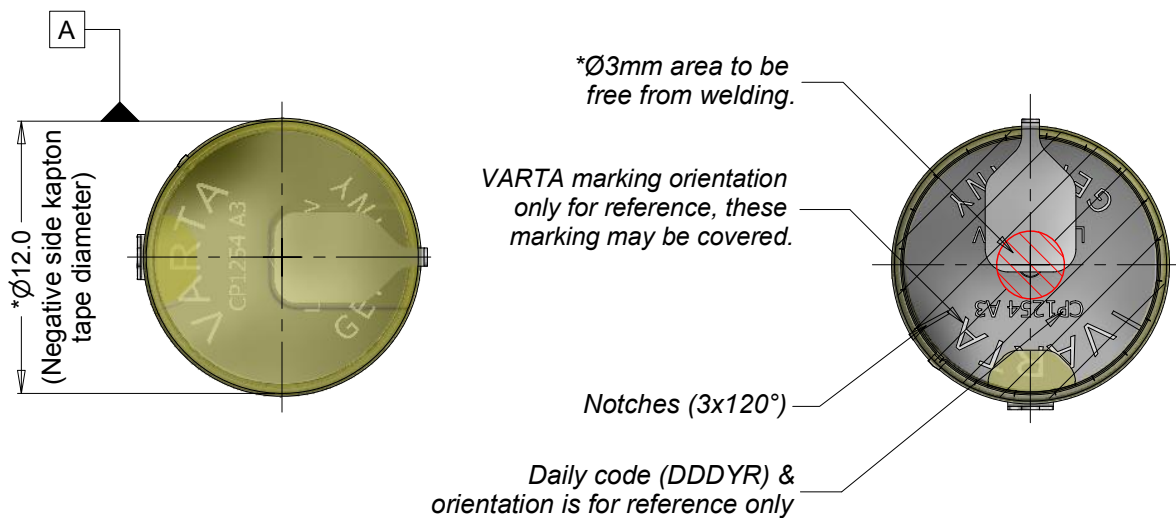
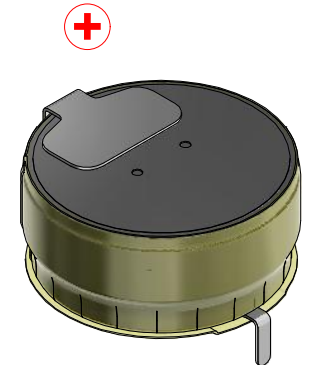
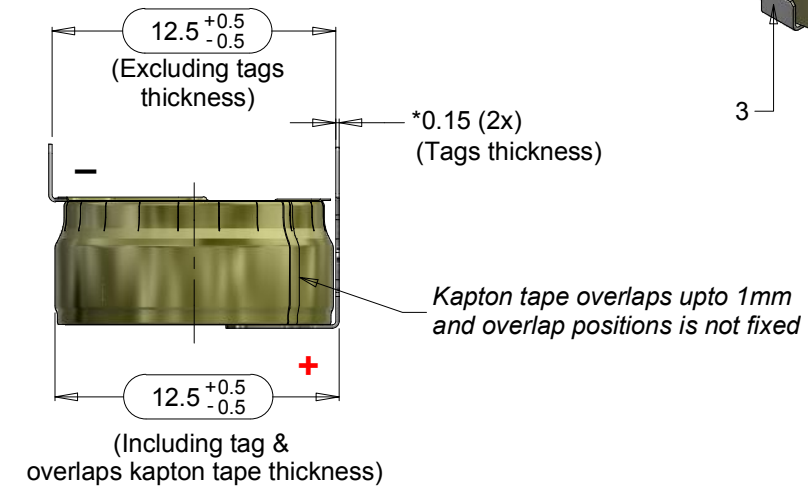
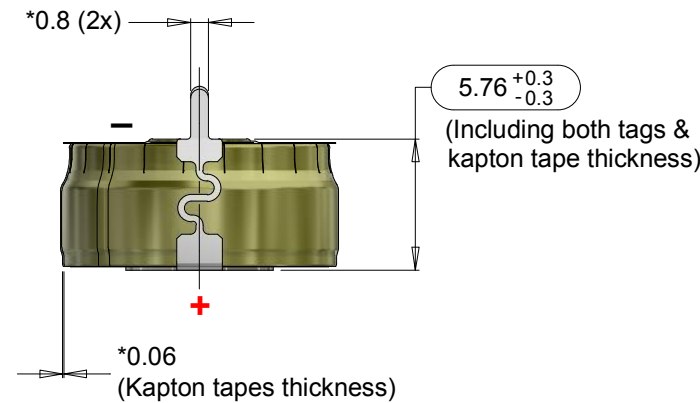
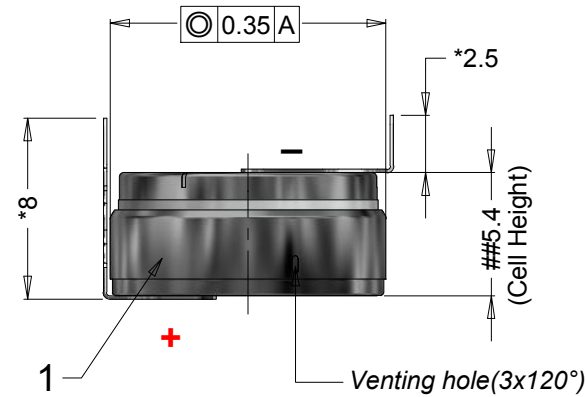

- Note : 1) \*Dimensions for reference only.  
2)  $\varnothing$  Dimensions to be considered for measurement.  
3) ##Max. 7 including cell deflection  
4) **Cell deflection space 1.5mm is needed in case of abuse conditions. Please contact VARTA for more details.**  
5) BATTERY VALIDATION INCLUDING SAFETY ELECTRONICS MUST BE DONE BY CUSTOMER ACCORDING TO UL2054.

Approx. wt : 2 g

No	AO No	Revision	Date	Name
1	20-R027	Changed kapton tape with slit and tongue	2020-01-17	Jadi
0	18-N018	Refer to provisional drawing P26-00718, rev 101	2018-04-09	Jadi

Projection :	Material : Refer to part list no: 722881	Description : CP1254 A3 PCBS SOC 30% with solder tags & kapton tapes
Dimension in mm	Date 2018-04-09	Name Jadi
Tolerance : ISO 2768-m	Checked 2019-12-24	Ian
Scale : NTS	Approved Sunil S	
Dwg. No : 722881		4 0 1
VKB Order No : 63125 201 128		

## The Netherlands



Elektrostraat 17  
NL-7483 PG Haaksbergen

T: +31 (0)53 573 33 33  
F: +31 (0)53 573 33 30  
E: nl@texim-europe.com

## Belgium



Zuiderlaan 14 bus 10  
B-1731 Zellik

T: +32 (0)2 462 01 00  
F: +32 (0)2 462 01 25  
E: belgium@texim-europe.com

## UK & Ireland



St. Mary's House, Church Lane  
Carlton Le Moorland  
Lincoln LN5 9HS

T: +44 (0)1522 789 555  
F: +44 (0)845 299 22 26  
E: uk@texim-europe.com

## Nordic region

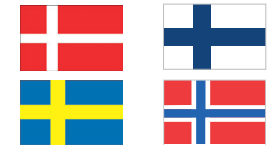

Sdr. Jagtvej 12  
DK-2970 Hørsholm

T: +45 88 20 26 30  
F: +45 88 20 26 39  
E: nordic@texim-europe.com

## Germany North



Bahnhofstrasse 92  
D-25451 Quickborn

T: +49 (0)4106 627 07-0  
F: +49 (0)4106 627 07-20  
E: germany@texim-europe.com

## Germany South



Martin-Kollar-Strasse 9  
D-81829 München

T: +49 (0)89 436 086-0  
F: +49 (0)89 436 086-19  
E: germany@texim-europe.com

## Austria



Warwitzstrasse 9  
A-5020 Salzburg

T: +43 (0)662 216 026  
F: +43 (0)662 216 026-66  
E: austria@texim-europe.com

## Italy



Via Matteotti 43  
IT-20864 Agrate Brianza (MB)

T: +39 (0)39 971 3293  
F: +39 (0)39 971 3293  
E: italy@texim-europe.com