

Chefree Technology Corp.

TFT COLOR LCD MODULE

MODEL: CH101OLHLWH-002

(Complied with RoHS)

WXGA

LVDS interface(1 Port)

Version: P01

Customer : _____
Approved By : _____
Date: _____

CHEFREE		
APPROVAL	CHECKER	PREPARE
Tim	Mark	Jacky

CONTENTS

1. RECORD OF REVISION.....	1
2. GENERAL DESCRIPTION AND FEATURES.....	2
3. MECHANICAL DIMENSIONS.....	3
4. INTERFACE PIN CONNECTION.....	4
5. BLOCK DIAGRAM.....	6
6. ABSOLUTE MAXIMUM RATINGS.....	7
7. ELECTRICAL CHARACTERISTICS.....	8
8. OPTICAL CHARACTERISTICS.....	9
9. TIMING SPECIFICATIONS.....	12
10. RELIABILITY TEST.....	16
11. LCM INSPECTION STANDARD.....	17
12. PRECAUTIONS FOR USE.....	18

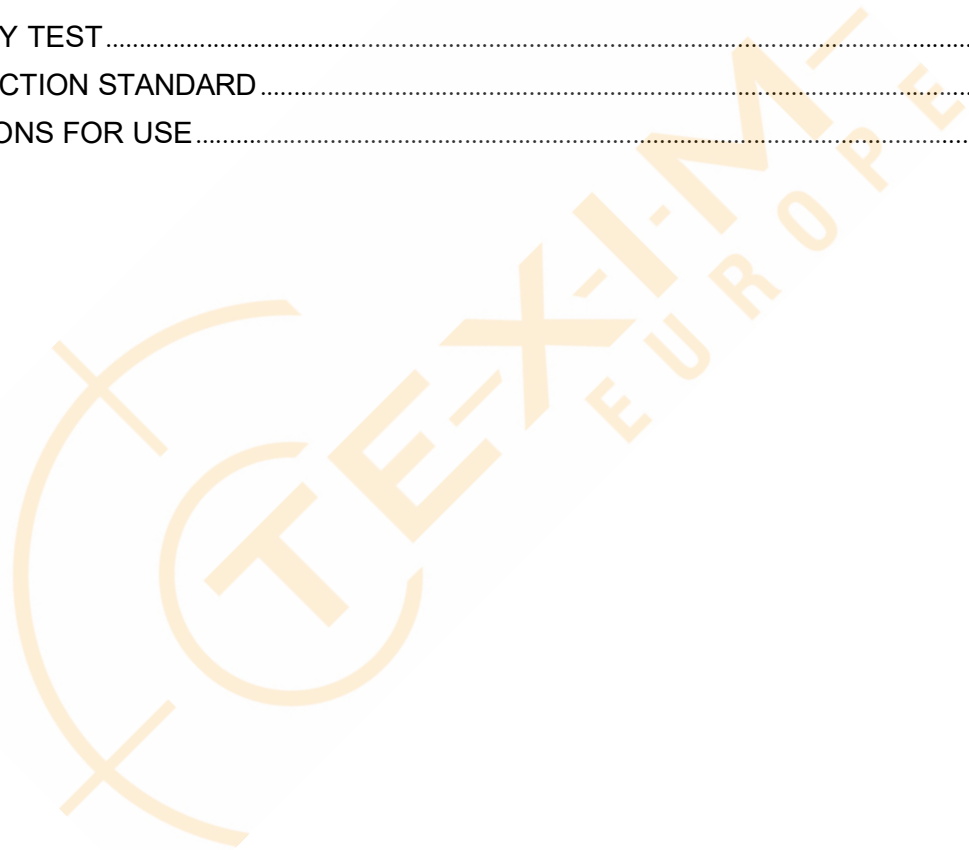

1. RECORD OF REVISION

Rev	DATE	PAGE	SUMMARY																																																																		
0.1	2015.10.16	ALL	Preliminary specification was first issued.																																																																		
0.2	2015.11.26	2	Modify 3.OUTLINE DIMENSIONS																																																																		
0.3	2015.12.09	2	Modify 3.OUTLINE DIMENSIONS																																																																		
		3	Modify 4. INTERFACE PIN CONNECTION																																																																		
		7	Modify 7.ELECTRICAL CHARACTERISTICS																																																																		
0.4	2015.12.16	7	Modify 7.ELECTRICAL CHARACTERISTICS <table border="1" style="width: 100%; border-collapse: collapse;"> <thead> <tr> <th>ITEM^⓪</th> <th>SYMBOL^⓪</th> <th>MIN.^⓪</th> <th>TYP.^⓪</th> <th>MAX.^⓪</th> <th>UNIT^⓪</th> <th>REMARK^⓪</th> </tr> </thead> <tbody> <tr> <td rowspan="2">Power Voltage For LCD^⓪</td> <td>VCC^⓪</td> <td>2.3^⓪</td> <td>2.5^⓪</td> <td>2.7^⓪</td> <td>V^⓪</td> <td>⓪</td> </tr> <tr> <td>ICC^⓪</td> <td>-^⓪</td> <td>(250)^⓪</td> <td>(300)^⓪</td> <td>mA^⓪</td> <td>Note 1^⓪</td> </tr> <tr> <td rowspan="2">Differential Input Threshold Voltage^⓪</td> <td>VIH^⓪</td> <td>0.8VCC^⓪</td> <td>-^⓪</td> <td>VCC^⓪</td> <td>mV^⓪</td> <td>⓪</td> </tr> <tr> <td>VIL^⓪</td> <td>0^⓪</td> <td>-^⓪</td> <td>0.2VCC^⓪</td> <td>mV^⓪</td> <td>⓪</td> </tr> </tbody> </table> <p>Note 1 : Test condition : VCC=2.5 ; Test Pattern : White^⓪ →</p> <table border="1" style="width: 100%; border-collapse: collapse;"> <thead> <tr> <th>ITEM^⓪</th> <th>SYMBOL^⓪</th> <th>MIN.^⓪</th> <th>TYP.^⓪</th> <th>MAX.^⓪</th> <th>UNIT^⓪</th> <th>REMARK^⓪</th> </tr> </thead> <tbody> <tr> <td rowspan="2">Power Voltage For LCD^⓪</td> <td>VCC^⓪</td> <td>2.5^⓪</td> <td>-^⓪</td> <td>3.3^⓪</td> <td>V^⓪</td> <td>⓪</td> </tr> <tr> <td>ICC^⓪</td> <td>-^⓪</td> <td>240^⓪</td> <td>300^⓪</td> <td>mA^⓪</td> <td>Note 1^⓪</td> </tr> <tr> <td rowspan="2">Differential Input Threshold Voltage^⓪</td> <td>VIH^⓪</td> <td>0.8VCC^⓪</td> <td>-^⓪</td> <td>VCC^⓪</td> <td>mV^⓪</td> <td>⓪</td> </tr> <tr> <td>VIL^⓪</td> <td>0^⓪</td> <td>-^⓪</td> <td>0.2VCC^⓪</td> <td>mV^⓪</td> <td>⓪</td> </tr> </tbody> </table> <p>Note 1 : Test condition : VCC=3.3V ; Test Pattern : White^⓪</p>	ITEM ^⓪	SYMBOL ^⓪	MIN. ^⓪	TYP. ^⓪	MAX. ^⓪	UNIT ^⓪	REMARK ^⓪	Power Voltage For LCD ^⓪	VCC ^⓪	2.3 ^⓪	2.5 ^⓪	2.7 ^⓪	V ^⓪	⓪	ICC ^⓪	- ^⓪	(250) ^⓪	(300) ^⓪	mA ^⓪	Note 1 ^⓪	Differential Input Threshold Voltage ^⓪	VIH ^⓪	0.8VCC ^⓪	- ^⓪	VCC ^⓪	mV ^⓪	⓪	VIL ^⓪	0 ^⓪	- ^⓪	0.2VCC ^⓪	mV ^⓪	⓪	ITEM ^⓪	SYMBOL ^⓪	MIN. ^⓪	TYP. ^⓪	MAX. ^⓪	UNIT ^⓪	REMARK ^⓪	Power Voltage For LCD ^⓪	VCC ^⓪	2.5 ^⓪	- ^⓪	3.3 ^⓪	V ^⓪	⓪	ICC ^⓪	- ^⓪	240 ^⓪	300 ^⓪	mA ^⓪	Note 1 ^⓪	Differential Input Threshold Voltage ^⓪	VIH ^⓪	0.8VCC ^⓪	- ^⓪	VCC ^⓪	mV ^⓪	⓪	VIL ^⓪	0 ^⓪	- ^⓪	0.2VCC ^⓪	mV ^⓪	⓪
ITEM ^⓪	SYMBOL ^⓪	MIN. ^⓪	TYP. ^⓪	MAX. ^⓪	UNIT ^⓪	REMARK ^⓪																																																															
Power Voltage For LCD ^⓪	VCC ^⓪	2.3 ^⓪	2.5 ^⓪	2.7 ^⓪	V ^⓪	⓪																																																															
	ICC ^⓪	- ^⓪	(250) ^⓪	(300) ^⓪	mA ^⓪	Note 1 ^⓪																																																															
Differential Input Threshold Voltage ^⓪	VIH ^⓪	0.8VCC ^⓪	- ^⓪	VCC ^⓪	mV ^⓪	⓪																																																															
	VIL ^⓪	0 ^⓪	- ^⓪	0.2VCC ^⓪	mV ^⓪	⓪																																																															
ITEM ^⓪	SYMBOL ^⓪	MIN. ^⓪	TYP. ^⓪	MAX. ^⓪	UNIT ^⓪	REMARK ^⓪																																																															
Power Voltage For LCD ^⓪	VCC ^⓪	2.5 ^⓪	- ^⓪	3.3 ^⓪	V ^⓪	⓪																																																															
	ICC ^⓪	- ^⓪	240 ^⓪	300 ^⓪	mA ^⓪	Note 1 ^⓪																																																															
Differential Input Threshold Voltage ^⓪	VIH ^⓪	0.8VCC ^⓪	- ^⓪	VCC ^⓪	mV ^⓪	⓪																																																															
	VIL ^⓪	0 ^⓪	- ^⓪	0.2VCC ^⓪	mV ^⓪	⓪																																																															
0.5	2016.01.05	2	Modify 3.OUTLINE DIMENSIONS																																																																		
		3	Modify 4. INTERFACE PIN CONNECTION																																																																		
		7	Modify 7.ELECTRICAL CHARACTERISTICS																																																																		
0.6	2016.01.20	7	Modify 7.ELECTRICAL CHARACTERISTICS																																																																		
0.7	2016.03.09	1	Modify (11)Module Weight(g) TBD→(300)																																																																		
		2	Modify 3.OUTLINE DIMENSIONS																																																																		
		8	Modify Luminance Uniformity 70Min→75Min,80Typ																																																																		
		17	Modify 12.PACKAGE INFORMATION																																																																		
0.8	2018.01.12	7	7.1 ELECTRICAL CHARACTERISTICS OF LCD ICC=240TYP.-->200TYP. 7.2 BACKLIGHT UNITS ILED=(460)TYP.-->590TYP. ; (600)MAX.-->740MAX.																																																																		
		17	11. LCM INSPECTION STANDARD Document Number : TBD-->OT101CBWDLV-02																																																																		
0.9	2020.10.23	ALL	FPC optimization.																																																																		

2.GENERAL DESCRIPTION AND FEATURES

(1)	Number Of Dots (Dots)	1280R.G.B X 800
(2)	Module Size(mm)	229.46(W) X149.1(H) X 4.8 (D)
(3)	Active Area(mm)	216.96(W) X135.60(H)
(4)	Pixel Pitch(mm)	0.1695(W) X0.1695(H)
(5)	LCD / Polarizer Model	TFT , Transmissive Normally Black,Hard coating
(6)	LED Backlight Color	White
(7)	Viewing Direction	Wide viewing angle Horizontal :Right side 85°(Typ),Left side85°(Typ) Vertical: Up side 85°(Typ),Down side 85°(Typ)
(8)	Gray Scale Inversion Direction	NO GSI
(9)	Color Configuration	R.G.B Vertical Stripe
(10)	Interface	LVDS
(11)	Module Weight(g)	280(Typ)

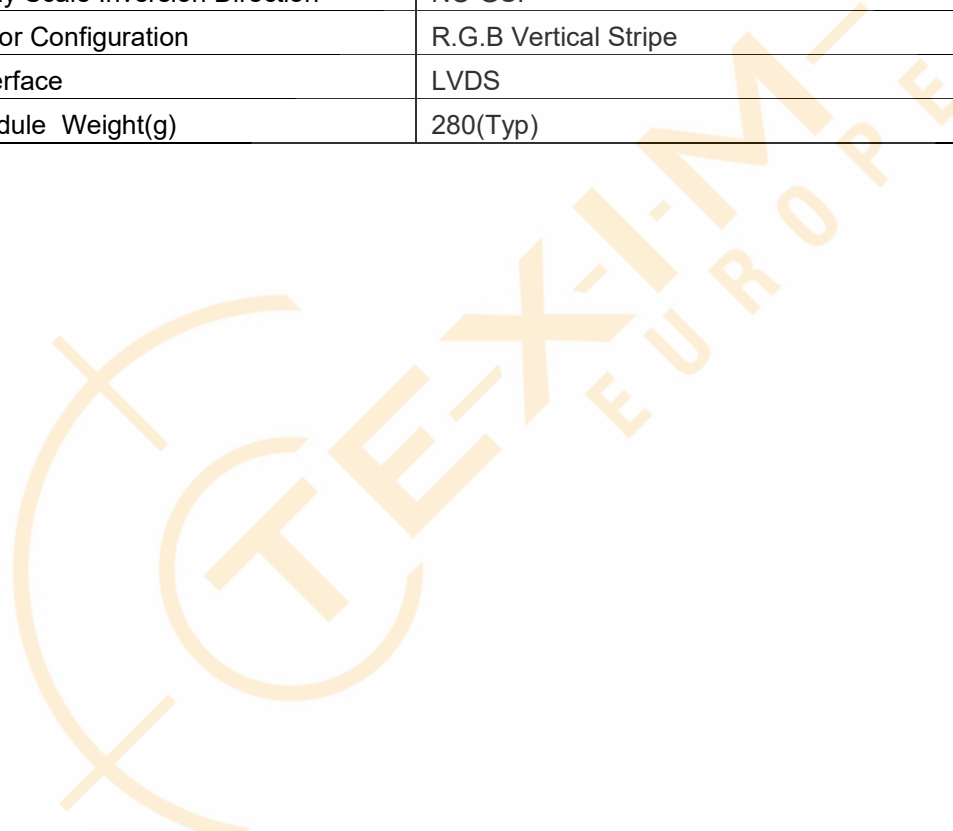

3. MECHANICAL DIMENSIONS

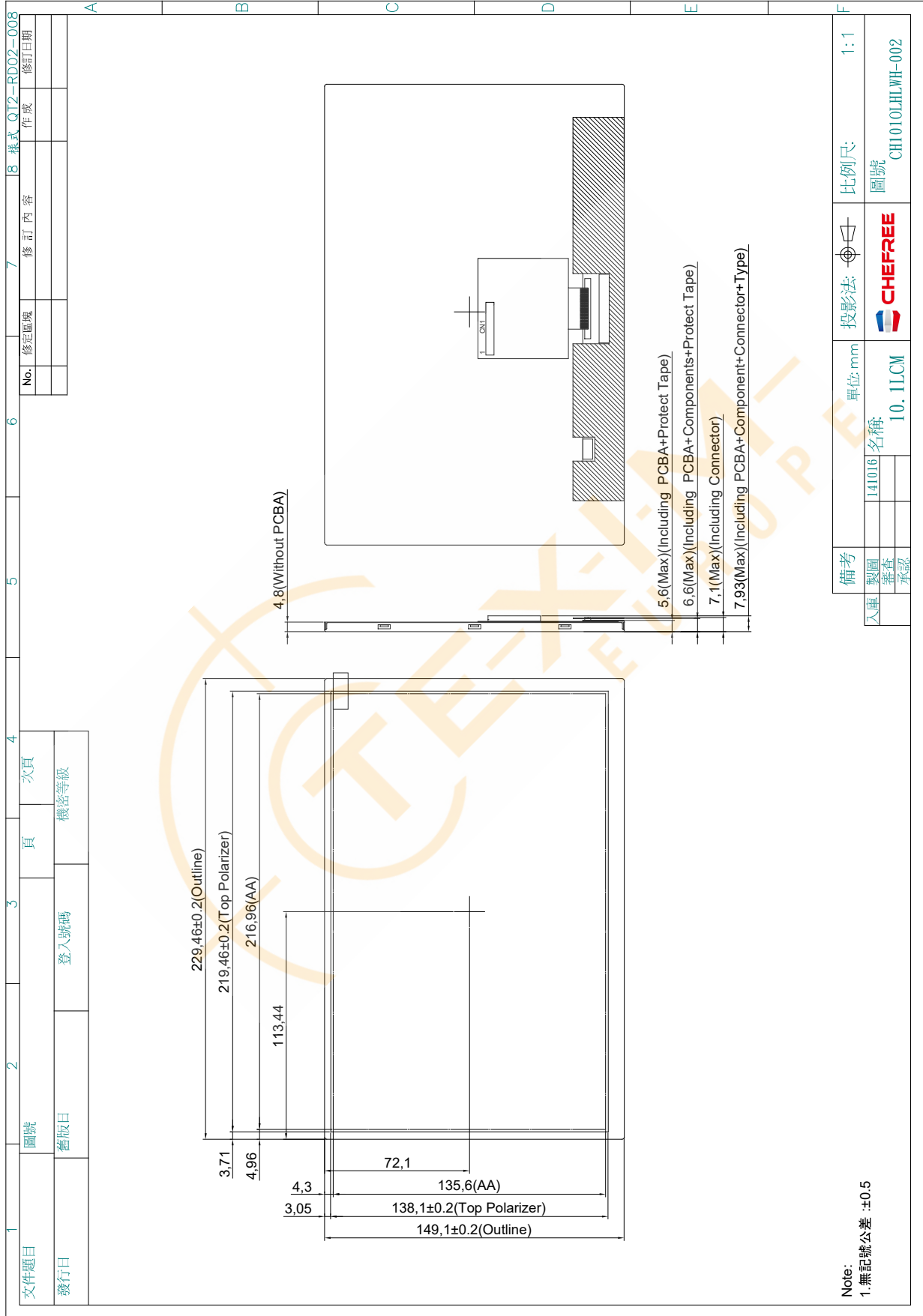

備考	單位:mm	投影法	比例尺:
入庫	141016		1:1
製圖	名稱:		圖號
審查	10.1LCM		CH101OLHLWH-002
承認			

4. INTERFACE PIN CONNECTION

CN1 Connector : I-PEX 20455-040E-12 or Equivalent

PIN NO.	SIGNAL	FUNCTION
1	VCC	Power Supply For Digital Circuit
2	VCC	Power Supply For Digital Circuit
3	VCC	Power Supply For Digital Circuit
4	NC	Non Connection (open)
5	NC	Non Connection (open)
6	NC	Non Connection (open)
7	NC	Non Connection (open)
8	RxIN0-	Differential Data Input, CH0(Negative)
9	RxIN0+	Differential Data Input, CH0(Positive)
10	GND	Ground
11	RxIN1-	Differential Data Input, CH1(Negative)
12	RxIN1+	Differential Data Input, CH1(Positive)
13	GND	Ground
14	RxIN2-	Differential Data Input, CH2(Negative)
15	RxIN2+	Differential Data Input, CH2(Positive)
16	GND	Ground
17	CLKIN-	Differential Clock Input(Negative)
18	CLKIN+	Differential Clock Input(Positive)
19	GND	Ground
20	RxIN3-	Differential Data Input, CH3(Negative)
21	RxIN3+	Differential Data Input, CH3(Positive)
22	GND	Ground
23	NC	Non Connection (open)
24	NC	Non Connection (open)
25	GND	Ground
26	GND	Ground
27	PWM	PWM Control Signal od LED Converter
28	EN	Enable Control Signal od LED Converter
29	VSS	LED Ground
30	VSS	LED Ground
31	VSS	LED Ground
32	VSS	LED Ground
33	VSS	LED Ground

PIN NO.	SIGNAL	FUNCTION
34	NC	Non Connection (open)
35	NC	Non Connection (open)
36	VLED	LED Power Supply
37	VLED	LED Power Supply
38	VLED	LED Power Supply
39	VLED	LED Power Supply
40	VLED	LED Power Supply



5. BLOCK DIAGRAM

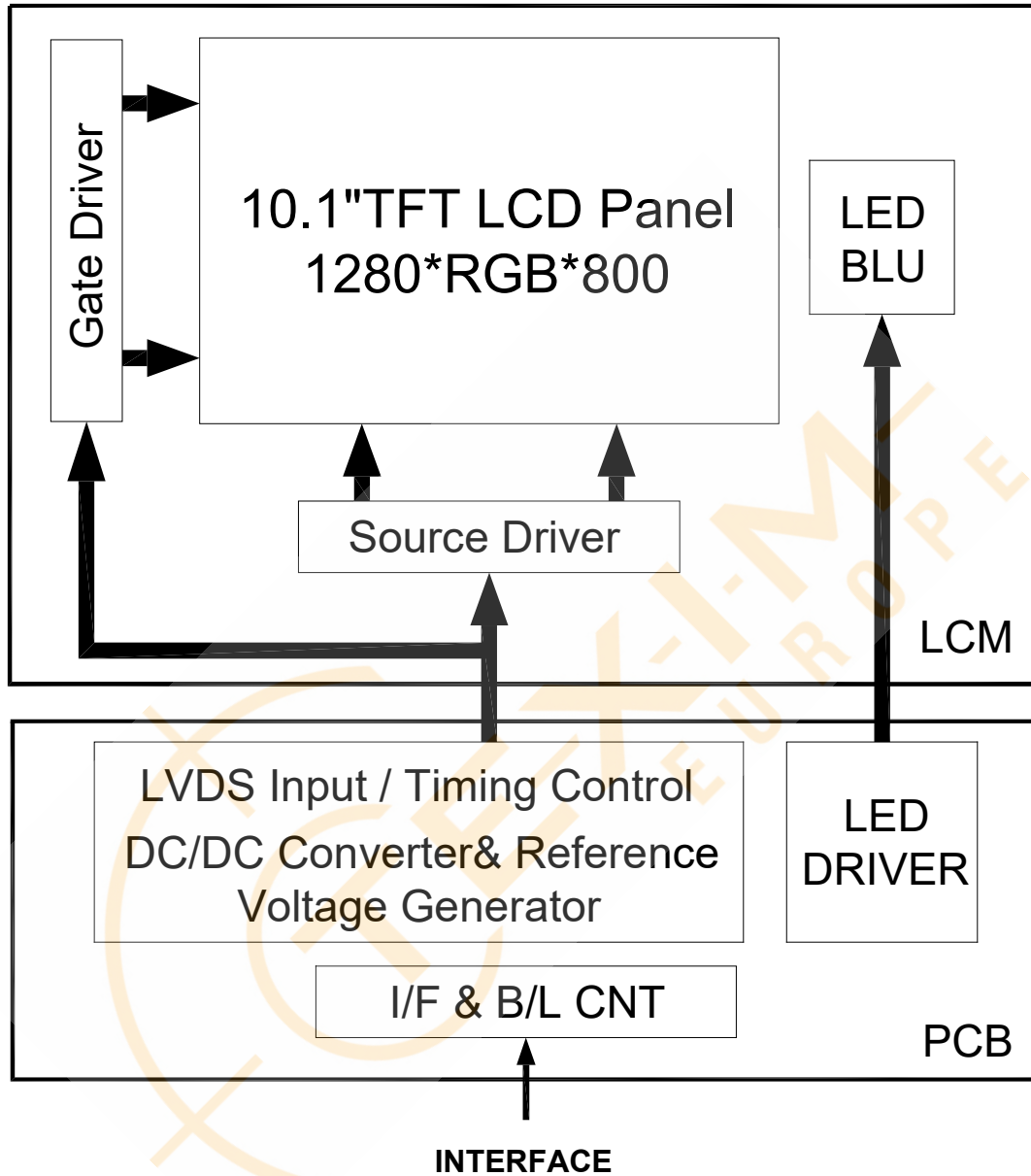

6.ABSOLUTE MAXIMUM RATINGS

6.1 ELECTRICAL ABSOLUTE MAXIMUM RATINGS

ITEM	SYMBOL	MIN.	MAX.	UNIT	REMARK
Supply Voltage	VCC	-0.3	+3.9	V	
	VLED	-4.5	+36	V	

Note: The absolute maximum rating values of this product not allowed to be exceeded at any times. Should be module be used with any of absolute maximum ratings exceeded. The characteristics of the module may not be recovered, or in an extreme case, the module may be permanently destroyed.

6.2 ENVIRONMENTAL ABSOLUTE MAXIMUM RATINGS

ITEM	OPERATING		STORAGE		REMARK
	MIN.	MAX.	MIN.	MAX.	
Ambient Temperature(°C)	-20	70	-30	80	Note 1,2
Humidity(% RH)	5 ~ 90		5 ~ 90		Note 3

Note 1 : The response time will become lower when operated at low temperature.

Note 2 : Background color changes slightly depending on ambient temperature.

Note 3 : Operating Ta=40°C & RH=90% ≤ 240Hrs.

7.ELECTRICAL CHARACTERISTICS

7.1 ELECTRICAL CHARACTERISTICS OF LCD

Ta=25°C

ITEM	SYMBOL	MIN.	TYP.	MAX.	UNIT	REMARK
Power Voltage For LCD	VCC	2.5	3.3	(3.6)	V	
	ICC	-	200	300	mA	Note 1
Differential Input Threshold Voltage	VIH	0.8VCC	-	VCC	mV	
	VIL	0	-	0.2VCC	mV	

Note 1 : Test condition : VCC=3.3V ; Test Pattern : White

7.2 BACKLIGHT UNITS

Ta=25°C

ITEM		SYMBOL	MIN.	TYP.	MAX.	UNIT
LED Driving Voltage		VLED	5.0	12.0	13.2	V
		ILED (VLED=12.0V)	-	590	740	mA
PWM Control Level	PWM High Level	-	3.0	3.3	3.6	V
	PWM Low Level	-	0	-	1.0	V
PWM Control Duty Ratio		-	0	-	100	%
PWM Control Frequency		f _{PWM}	100	-	2000	Hz
LED Life Time (For Reference Only)		Ta=25°C 60-70%RH (Note 1)	-	50000	-	Hr

Note 1: The LED of B/L is drive by current only, drive voltage is for reference only. drive voltage can make driving current under safety area(current between minimum and maximum). 50,000 hours is only an estimate for reference.

Note 2: The lifetime of LED is defined as the time when it continues to operate under the conditions at Ta= 25 ±2°C and PWM = 100% (LED forward current) until the brightness becomes ≤50% of its original value.

Note 3: ADJ signal Vp-p =3.0 ~ 3.6 V, operation frequency: 100Hz ~ 2000Hz:

PWM DIMMING DUTY

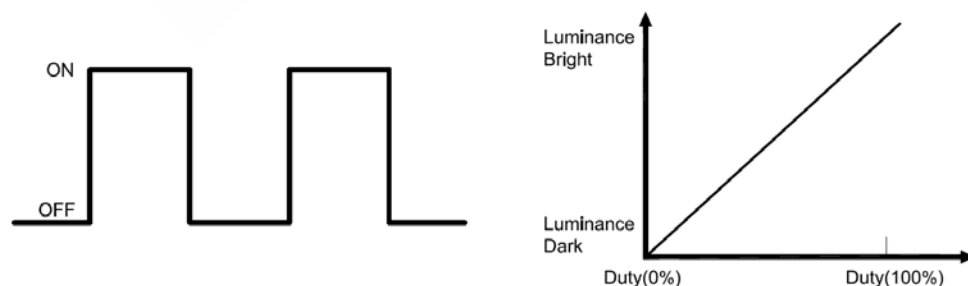

8.OPTICAL CHARACTERISTICS

Ta=25°C

ITEM	SYMBOL	CONDITIONS	MIN.	TYP.	MAX.	UNIT	REMARK
Contrast Ratio	CR	Viewing Normal Angle $\Theta_x=\Theta_y=0^\circ$	600	800	-	-	Note 1
Response Time	TR+TF		-	25	50	ms	Note 2
Color chromaticity	White		x	(0.26)	(0.31)	(0.36)	-
		y	(0.27)	(0.32)	(0.37)	-	
Viewing Angle	Hor.	θ_L	75	85	-	Deg.	Note 3
		θ_R	75	85	-		
	Ver.	θ_T	75	85	-		
		θ_B	75	85	-		
Luminance	L	PWM=100%	(400)	(600)	-	cd/m ²	
Luminance Uniformity	YU		75	80	-	%	Note 5

Note 1 : Definition of Contrast Ratio (CR) :

The contrast ratio can be calculated by the following expression.

$$\text{Contrast Ratio (CR)} = L_{63}/L_0$$

L63 : Luminance of gray level 63

L0 : Luminance of gray level 0

$$CR = CR(5)$$

CR(X) is corresponding to the Contrast Ratio of the point X at Figure in Note 5

Note 2 : Definition of Response Time (TR,TF)

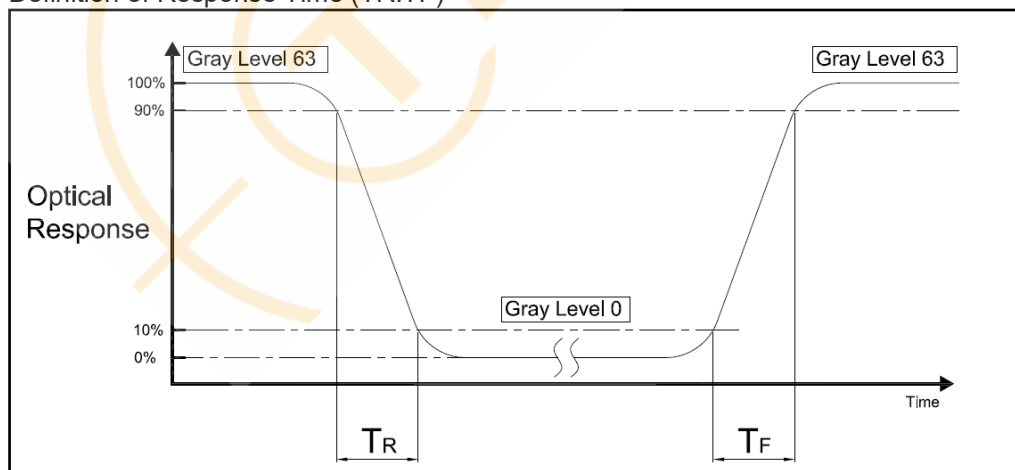

Note 3 : Definition of Viewing Angle

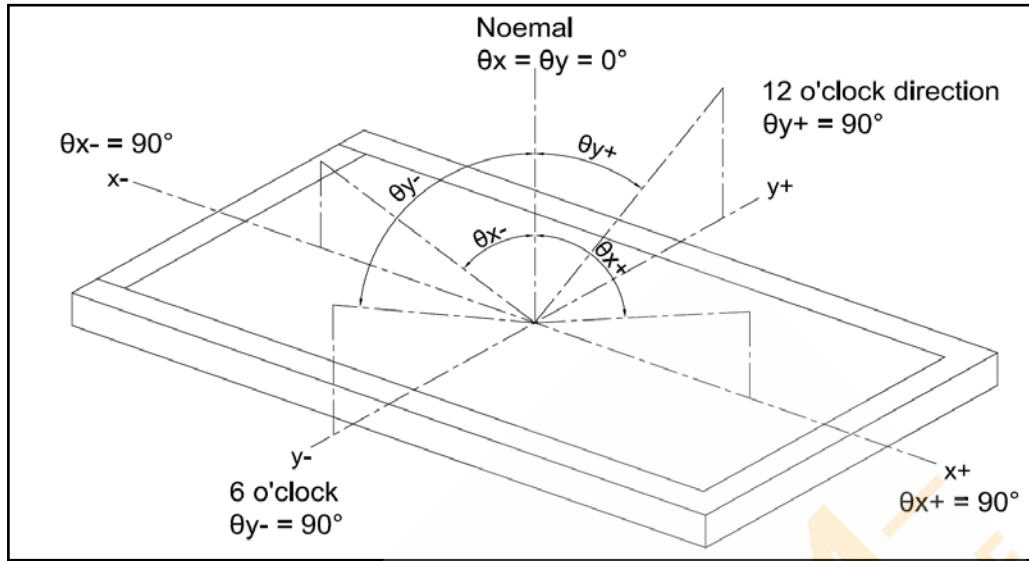

Note 4 : Measurement Set-Up:

The LCD module should be stabilized at a given temperature for 20 minutes to avoid abrupt temperature change during measuring. In order stabilize the luminance, the measurement should be executed after lighting Backlight for 20 minutes in a windless room.

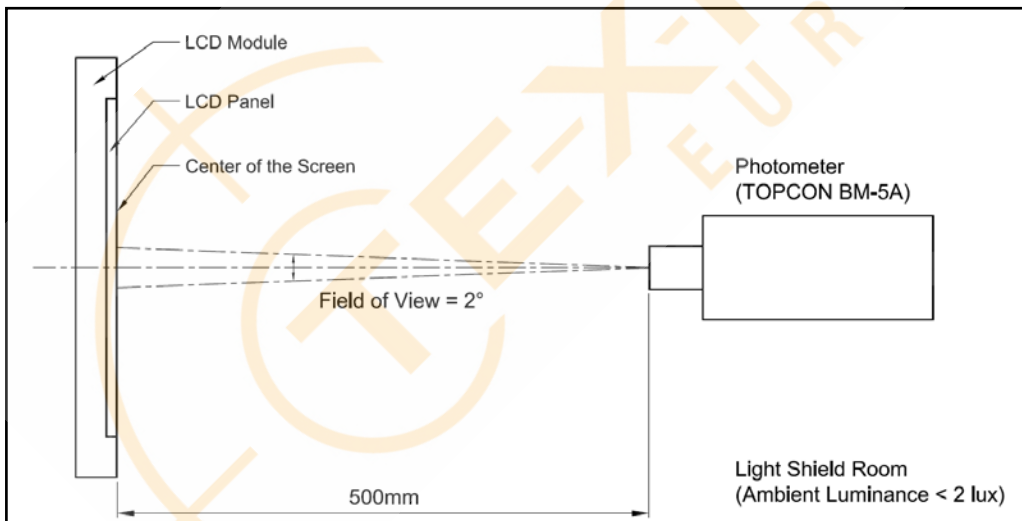

\

Note 5 :

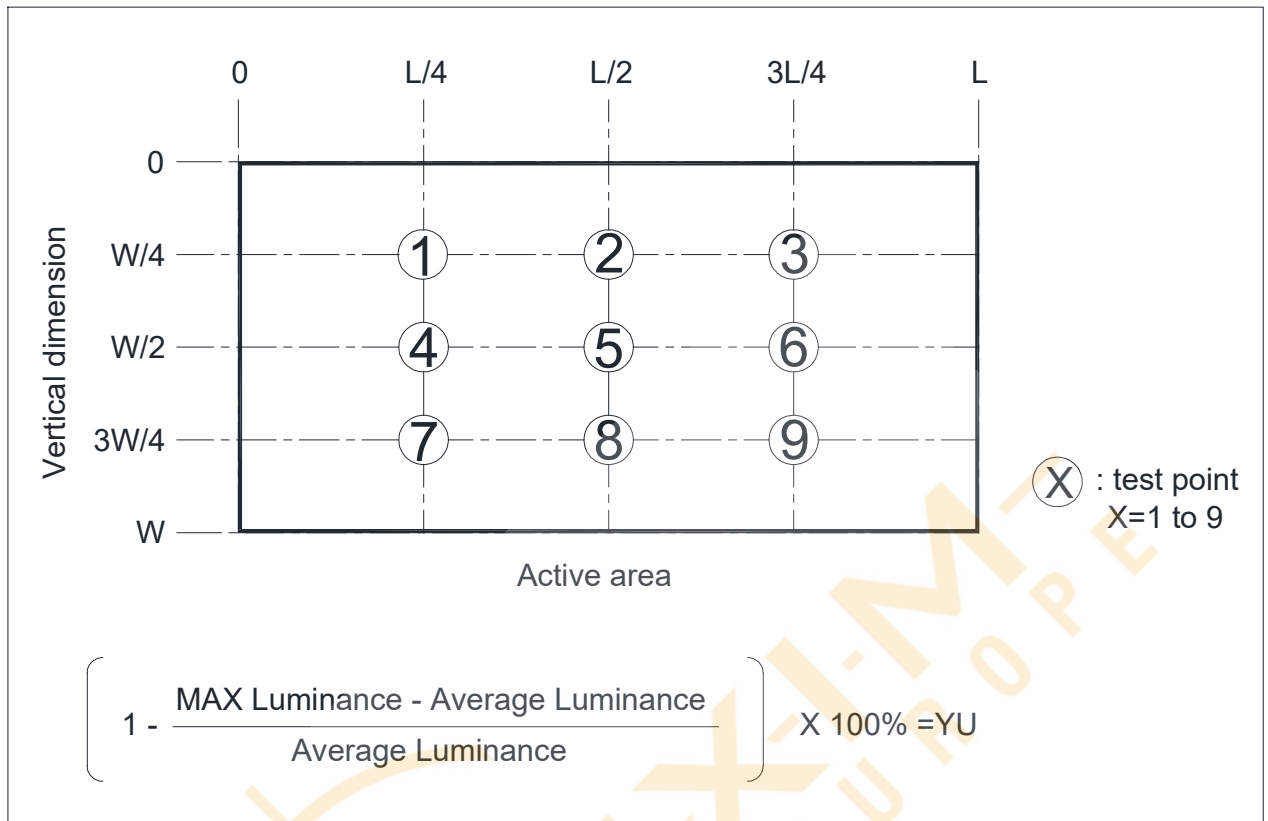

9. TIMING SPECIFICATIONS

9.1.1 POWER ON

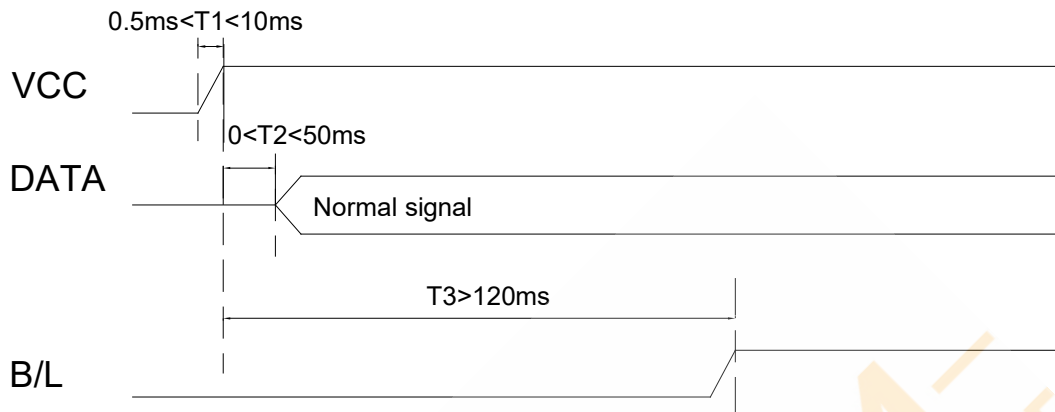

9.1.2 POWER OFF

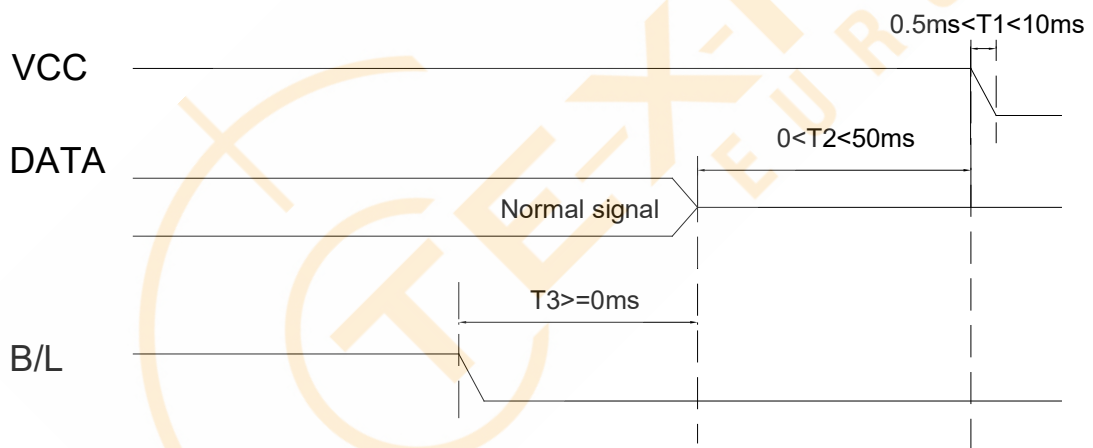

9.2 RESET TIMING CHARACTERISTICS

AC Electrical Characteristics

PARAMETER	SYMBOL	MIN	TYP	MAX	UNIT	REMARK
LVDS Differential input high Threshold voltage	RxVTH	-	-	+100	mV	Rxvcm=1.2V
LVDS Differential input low Threshold voltage	RxVTL	-100	-	-	mV	
LVDS Differential input common mode voltage	RxVCM	0.7	-	1.6	V	
LVDS Differential input	VID	200	-	600	mV	

Single-end signals

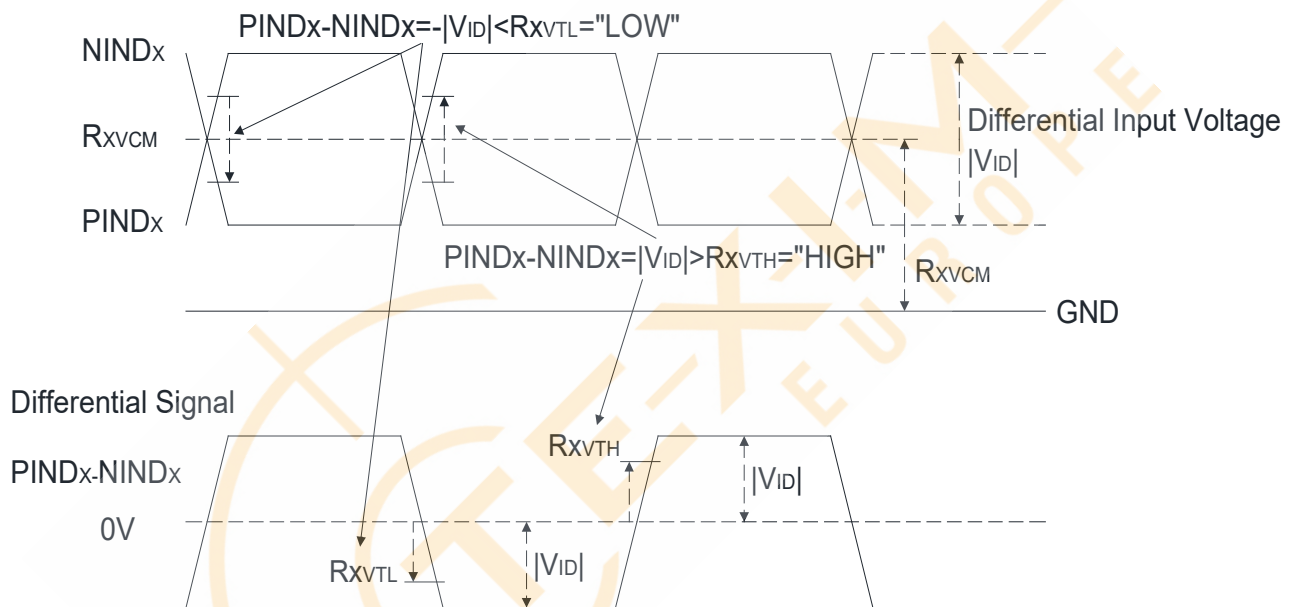

9.3 Timing

PARAMETER	SYMBOL	MIN	TYP	MAX	UNIT	REMARK
Clock Frequency	1/Tc	68.9	71.1	73.4	MHz	Frame rate=60Hz
Horizontal display area	thd	1280			Tc	
HS period time	th	1410	1440	1470	Tc	
HS Width+Back Porch+Front Porch	thw+thbp+thfp	130	160	190	Tc	
Vertical display area	tvd	800			tH	
VS period time	tv	815	823	833	tH	
VS Width+Back Porch+Front Porch	tvw+tvbp+tvfp	15	23	33	tH	

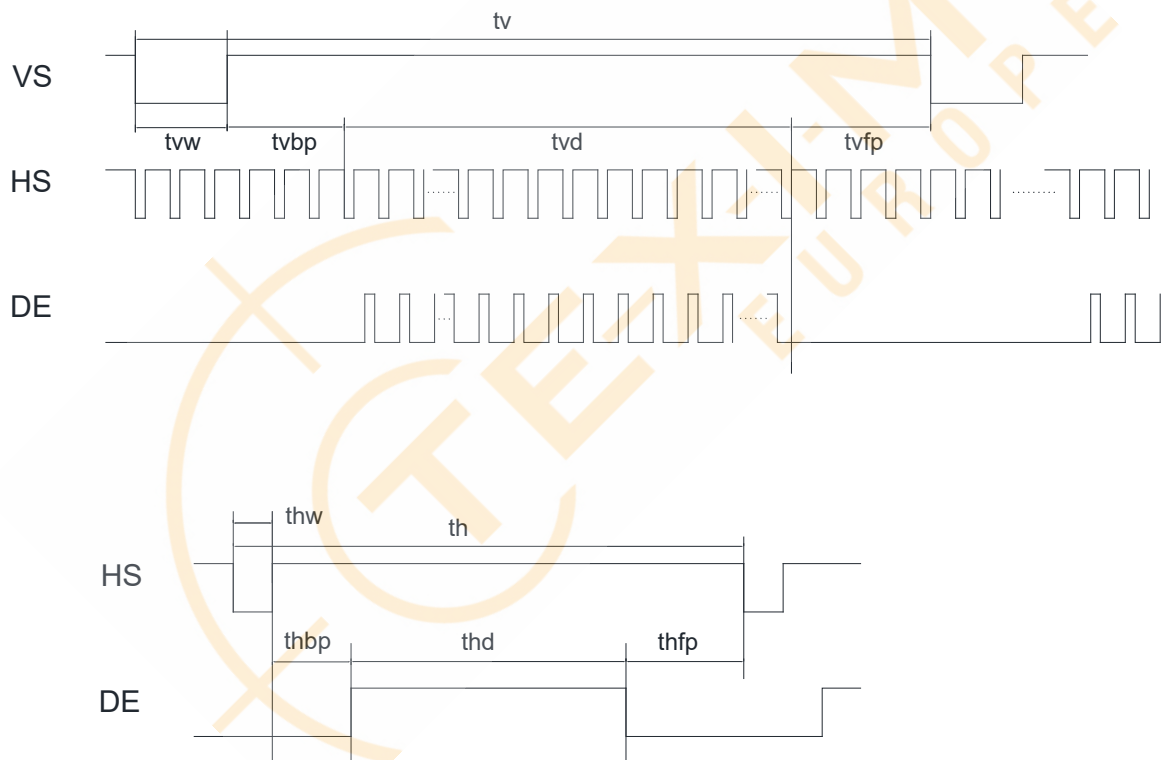

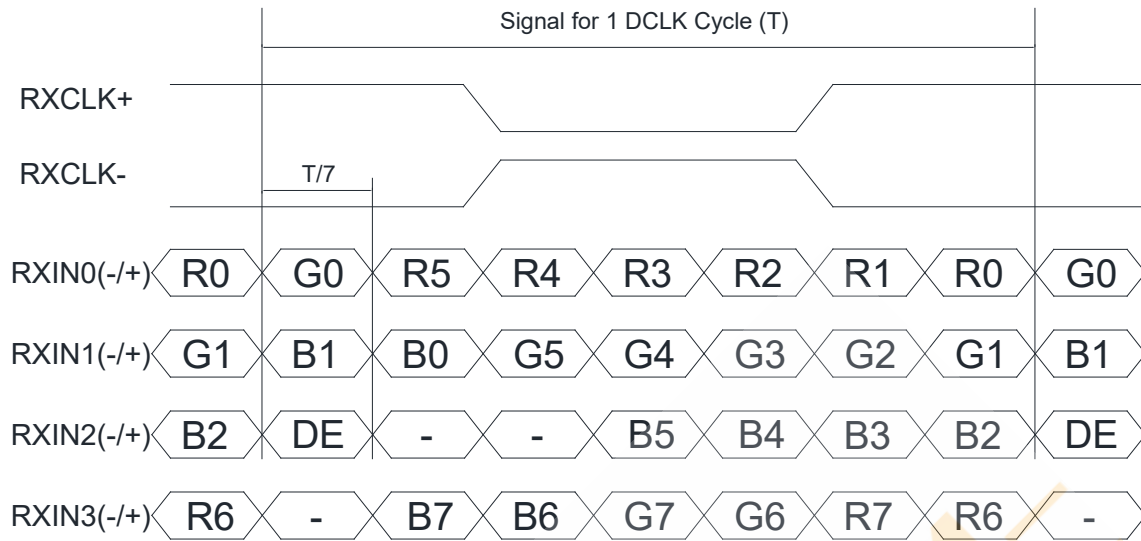
9.4 Data Input format

10. RELIABILITY TEST

ENVIRONMENTAL TEST				
NO.	ITEM	CONDITIONS	TIME PERIOD	REMARK
1	High Temperature Storage	80°C	240Hours	Note 1,4
2	Low Temperature Storage	-30°C	240Hours	Note 1,4
3	High Temperature Humidity Operation	40°C,90%RH	240Hours	Note 4
4	High Temperature Operation	70°C	240Hours	Note 2,4
5	Low Temperature Operation	-20°C	240Hours	Note1,4
6	Temperature Cycle	-30°C ~ 80°C (30min) (30min)	100CYCLE	Note 4

Note1 : Ta is the ambient temperature of samples.

Note2 : Ts is the temperature of panel's surface.

Note3 : In the standard condition, there shall be no practical problem that may affect the display function. After the reliability test, the product only guarantees operation, but don't guarantee all of the cosmetic specification.

Note4 : Before cosmetic and function test, the product must have enough recovery time, at least 2 hours at room temperature.

10.1 VIBRATION TEST:

10.1.1 STATE LABORATORY ENVIRONMENT :

Room temperature : $25\pm 3^{\circ}\text{C}$
Relative humidity : $55\pm 20\% \text{RH}$

10.1.2 TEST METHOD / SPECIFICATION :

Sample Status : Non-packaged single state
Waveform : Sine
Frequency : 10~55HZ
Full amplitude : 1.5mm
Vibration direction : X,Y,Z Axis(3 Axial)
Test time : Each 120minZ Axis , Altogether 360min

10.2 MECHANICAL SHOCK TEST :

10.1.1 STATE LABORATORY ENVIRONMENT :

Room temperature : $25\pm 3^{\circ}\text{C}$
Relative humidity : $55\pm 20\% \text{RH}$

10.1.2 TEST METHOD / SPECIFICATION :

Sample Status : Non-packaged single state
Waveform : Half-sine
Acceleration : 50G
Shock Time : 6ms
Impact direction : 3Directions($\pm X, \pm Y, \pm Z$ axes)
Number of shocks : Each direction 3 Secondary , Altogether 18 Secondary

11. LCM INSPECTION STANDARD

Inspection specifications refer CHEFREE Technology Corp. LCM INSPECTION STANDARD Document.
Document Number : CH101OLHLWH-002

12.PRECAUTIONS FOR USE

12.1 SAFETY

- (1) Do not swallow any liquid crystal, even if there is no proof that liquid crystal is poisonous.
- (2) If the LCD panel breaks, be careful not to get liquid crystal to touch your skin.
- (3) If skin is exposed to liquid crystal, wash the area thoroughly with alcohol or soap.

12.2 STORAGE CONDITIONS

- (1) Store the panel or module in a dark place where the temperature is $23\pm 5^{\circ}\text{C}$ and the humidity is below $50\pm 20\% \text{RH}$.
- (2) Store in anti-static electricity container.
- (3) Store in clean environment, free from dust, active gas, and solvent.
- (4) Do not place the module near organics solvents or corrosive gases.
- (5) Do not crush, shake, or jolt the module.

12.3 HANDLING PRECAUTIONS

- (1) Avoid static electricity which can damage the CMOS LSI.
- (2) The polarizing plate of the display is very fragile. So, please handle it very carefully.
- (3) Do not give external shock.
- (4) Do not apply excessive force on the surface.
- (5) Do not wipe the polarizing plate with a dry cloth, as it may easily scratch the Surface of plate.
- (6) Do not use ketonics solvent & Aromatic solvent, use with a soft cloth soaked with a cleaning naphtha solvent.
- (7) Do not operate it above the absolute maximum rating.
- (8) Do not remove the panel or frame from the module.
- (9) When the module is assembled, it should be attached to the system firmly, Be careful not to twist and bend the module.
- (10) Wipe off water droplets or oil immediately . If you leave the droplets for a long time, staining and discoloration may occur.
- (11) If the liquid crystal material leaks from the panel, it should be kept away from the eyes or mouth. In case of contact with hands, legs or clothes, it must be washed away thoroughly with soap.

12.4 WARRANTY

- (1) Acceptance inspection period
The period is within one month after the arrival of contracted commodity at the buyer's factory site.
- (2) Applicable warrant period
The period is within 12 months since the date of shipping out under normal using and storage conditions.

The Netherlands



Elektrostraat 17
NL-7483 PG Haaksbergen

T: +31 (0)53 573 33 33
F: +31 (0)53 573 33 30
E: nl@texim-europe.com

Belgium



Zuiderlaan 14 bus 10
B-1731 Zellik

T: +32 (0)2 462 01 00
F: +32 (0)2 462 01 25
E: belgium@texim-europe.com

UK & Ireland



St. Mary's House, Church Lane
Carlton Le Moorland
Lincoln LN5 9HS

T: +44 (0)1522 789 555
F: +44 (0)845 299 22 26
E: uk@texim-europe.com

Germany North



Bahnhofstrasse 92
D-25451 Quickborn

T: +49 (0)4106 627 07-0
F: +49 (0)4106 627 07-20
E: germany@texim-europe.com

Germany South



Martin-Kollar-Strasse 9
D-81829 München

T: +49 (0)89 436 086-0
F: +49 (0)89 436 086-19
E: germany@texim-europe.com

Austria



Warwitzstrasse 9
A-5020 Salzburg

T: +43 (0)662 216 026
F: +43 (0)662 216 026-66
E: austria@texim-europe.com

Nordic region



Sdr. Jagtvej 12
DK-2970 Hørsholm

T: +45 88 20 26 30
F: +45 88 20 26 39
E: nordic@texim-europe.com

Italy



Via Matteotti 43
IT-20864 Agrate Brianza (MB)

T: +39 (0)39 971 3293
F: +39 (0)39 971 3293
E: italy@texim-europe.com

General information



info@texim-europe.com
www.texim-europe.com