

Chefree Technology Corp.

TFT COLOR LCD MODULE

MODEL: CH070TLHLWN-CT1-I

(Complied with RoHS)

WXGA
LVDS interface

Version: P01

Customer : _____
Approved By : _____
Date: _____

CHEFREE		
APPROVAL	CHECKER	PREPARE
Tim	Mark	Benson

CONTENTS

1.RECORD OF REVISION.....	2
2.MECHANICAL SPECIFICATIONS	3
3.OUTLINE DIMENSIONS.....	4
4. INTERFACE PIN CONNECTION	5
5. BLOCK DIAGRAM.....	7
6. ABSOLUTE MAXIMUM RATINGS	8
7. ELECTRICAL CHARACTERISTICS	9
8. OPTICAL CHARACTERISTICS.....	11
9. TOUCH PANEL SPECIFICATIONS	14
10. TIMING SPECIFICATIONS.....	15
11. RELIABILITY TEST	18
12. PRECAUTIONS FOR USE.....	19

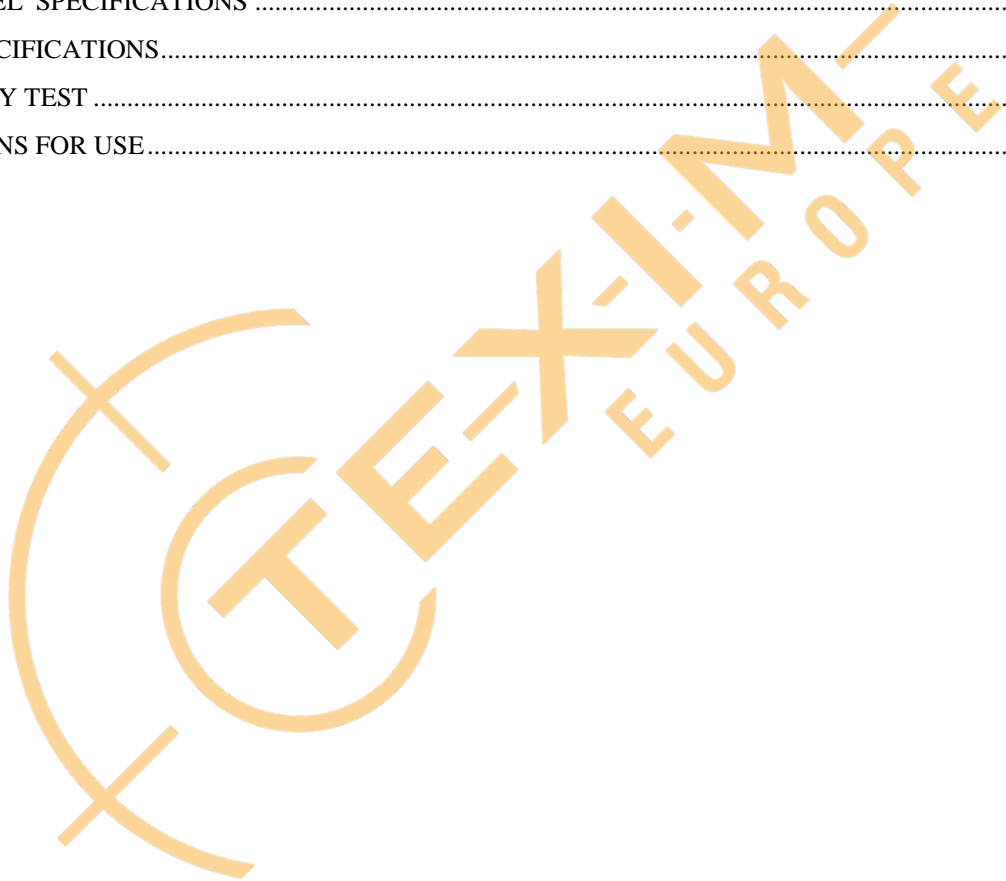

1. RECORD OF REVISION

Rev	DATE	PAGE	SUMMARY
P00	2021.02.03	ALL	Preliminary specification
P01	2021.05.26	2,3	Drawing updated for TP



2. MECHANICAL SPECIFICATIONS

(1)	Number of Dots	1280(R.G.B) x 800
(2)	Module Size(mm)	183.26 x 127.1 x 10.25 (D)
(3)	Active Area(mm)	149.76(H) x 93.60 (V)
(4)	Pixel Pitch(mm)	0.117(H) x 0.117(V)
(5)	LCD Model	SFT with Normally Black
(6)	Backlight Color	White, LED
(7)	Viewing Direction	All direction
(8)	Electrical Interface	LVDS Interface
(9)	Color Configuration	R.G.B Vertical Stripe
(10)	Touch Panel Mode	Projected Capacitive Touch
(11)	Module Weight(g)	TBD

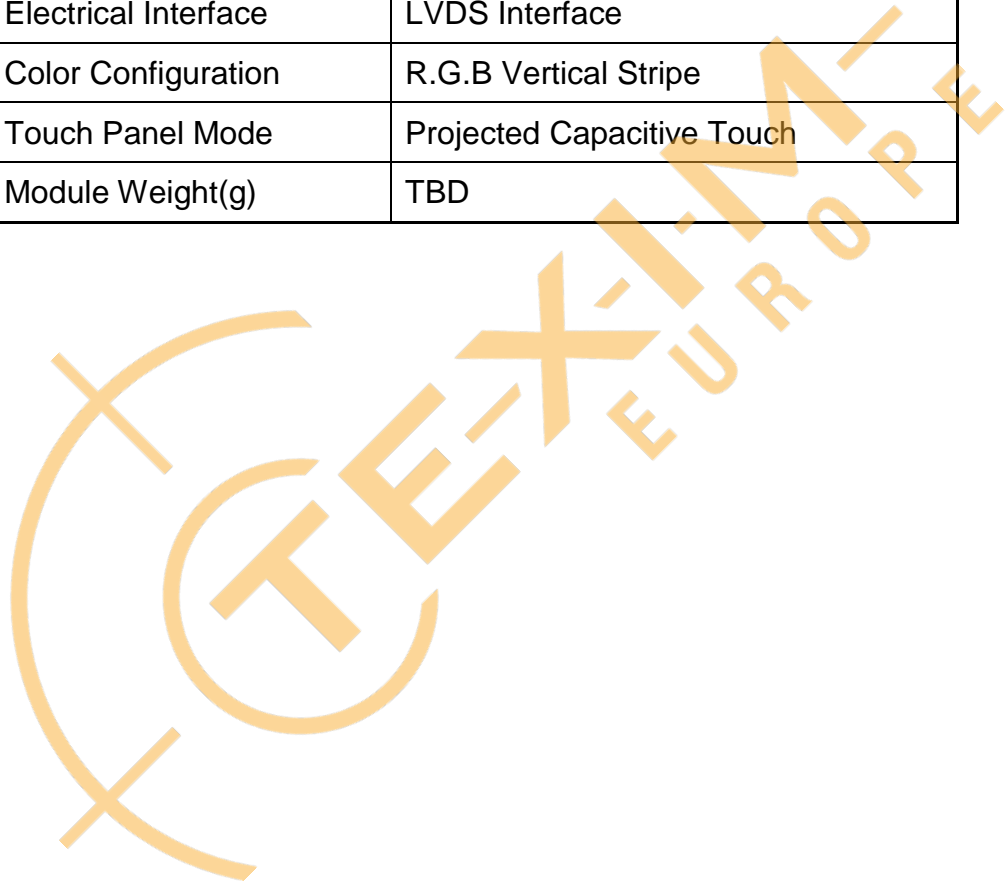

3. OUTLINE DIMENSIONS

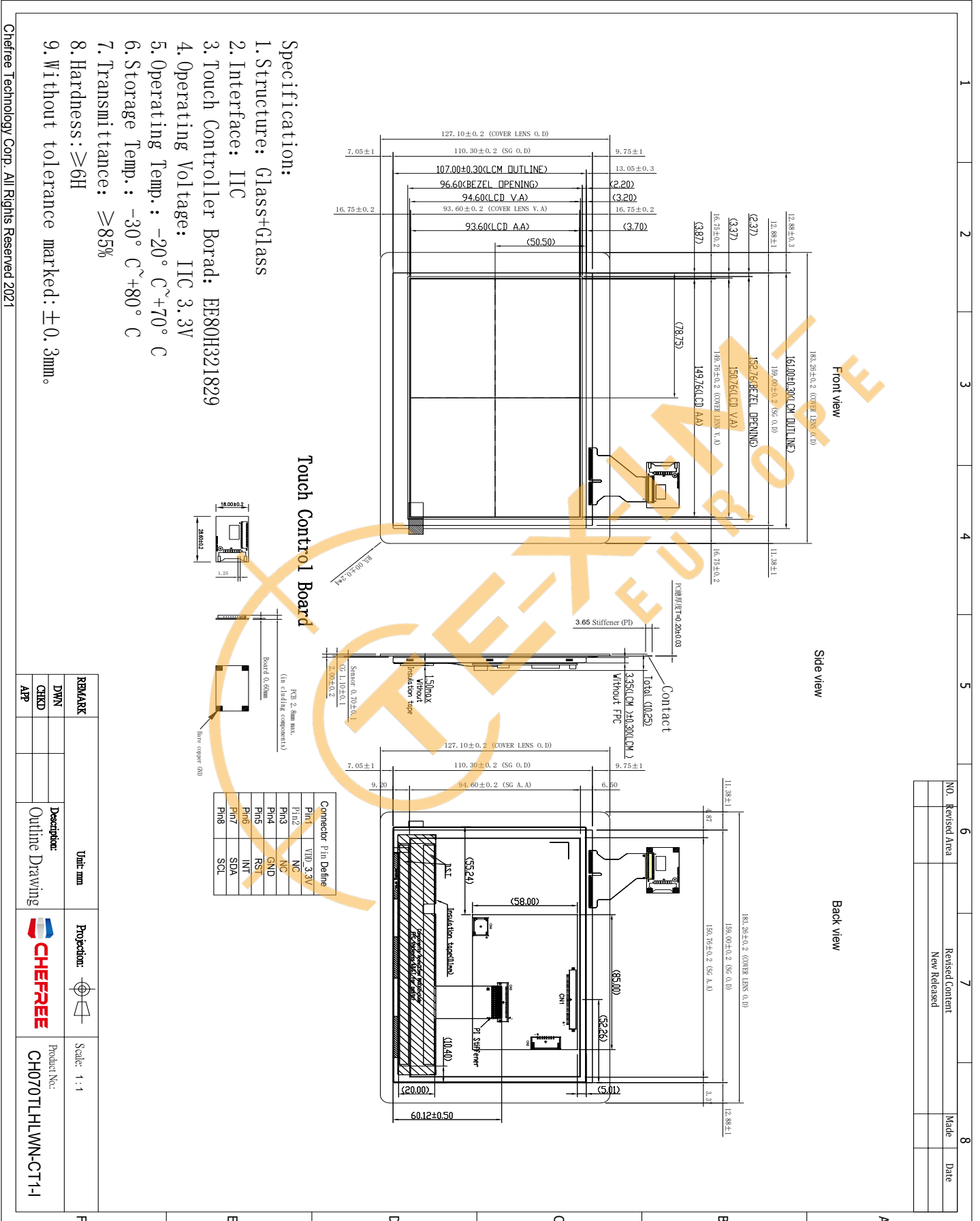

4. INTERFACE PIN CONNECTION

4.1 TFT LCM PANEL PIN DEFINE

CN1 Connector : STM MSBK2407P30 RF:HB or Equivalent

PIN NO.	Definition	I/O	Description	Remark
1	GND	P	Ground	
2	GND	P	Ground	
3	EN	I	Enable Control for Backlight	
4	PWM	I	Brightness Control for Backlight	
5	VLED	P	Power Supply for LED Backlight (5V)	
6	VLED	P	Power Supply for LED Backlight (5V)	
7	VDD	P	Power Supply for Digital Circuit (3.3V)	
8	NC	-	No connection	
9	NC	-	No connection	
10	GND	P	Ground	
11	RxIN0-	I	Negative LVDS Differential Data Input	
12	RxIN0+	I	Positive LVDS Differential Data Input	
13	GND	P	Ground	
14	RxIN1-	I	Negative LVDS Differential Data Input	
15	RxIN1+	I	Positive LVDS Differential Data Input	
16	GND	P	Ground	
17	RxIN2-	I	Negative LVDS Differential Data Input	
18	RxIN2+	I	Positive LVDS Differential Data Input	
19	GND	P	Ground	
20	RxCLK-	I	Negative LVDS Differential Clock Input	
21	RxCLK+	I	Positive LVDS Differential Clock Input	
22	GND	P	Ground	
23	RxIN3-	I	Negative LVDS Differential Data Input	
24	RxIN3+	I	Positive LVDS Differential Data Input	
25	NC	-	No connection	
26	NC	-	No connection	
27	NC	-	No connection	
28	NC	-	No connection	
29	NC	-	No connection	
30	NC	-	No connection	

Note : 'P' stand for Power, 'I' stand for Input

4.2 CTP Specification:

JP1 Connector : 50278-00801-001 or Equivalent

PIN NO.	Definition
1	VCC_3.3V
2	NC
3	NC
4	GND
5	RST
6	INT
7	SDA
8	SCL



5. BLOCK DIAGRAM

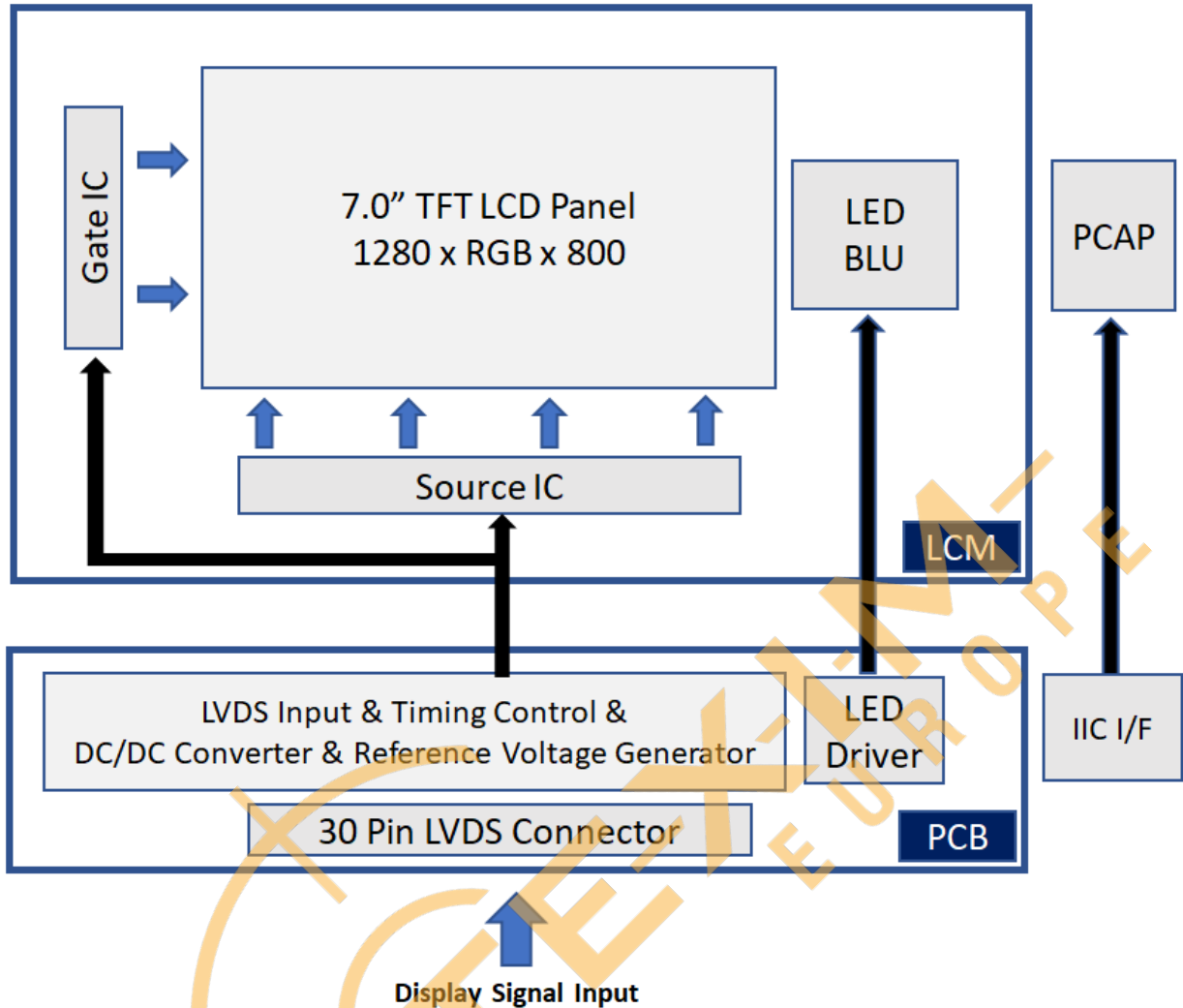

6. ABSOLUTE MAXIMUM RATINGS

6.1 ELECTRICAL ABSOLUTE MAXIMUM RATINGS

ITEM	SYMBOL	MIN.	MAX.	UNIT	REMARK
Power Supply Voltage	VDD	-0.3	4.5	V	
Backlight Supply Voltage	VLED	-	8	V	
Power Voltage For CTP	/	/	/	V	

Note : The absolute maximum rating values of this product not allowed to be Exceeded at any times. Should be module be used with any of absolute maximum ratings exceeded. The characteristics of the module may not be recovered, or in an extreme case, the module may be permanently destroyed.

6.2 ENVIRONMENTAL ABSOLUTE MAXIMUM RATINGS

ITEM	OPERATING		STORAGE		REMARK
	MIN.	MAX.	MIN.	MAX.	
Ambient Temperature(°C)	-20	70	-30	80	Note 1,2
Humidity(% RH)	10~90(Note3)		10~90(Note 3)		-

Note 1 : The response time will become lower when operated at low temperature.

Note 2 : Background color changes slightly depending on ambient temperature.

Note 3 : Storage Ta=40°C & RH=90% ≤ 96Hrs

7. ELECTRICAL CHARACTERISTICS

7.1 DC Electrical Characteristics

Ta=25°C

ITEM	SYMBOL	MIN.	TYP.	MAX.	UNIT	REMARK
Power Voltage For LCD	VDD	3.0	3.3	3.6	V	
	IDD	-	TBD	-	mA	Note1
Differential Input Threshold	RxVTH	-	-	0.1	V	Note2
	RxVTL	-0.1	-		V	
Input Voltage Range	RxVIN	0	-	Vdd-1.0	V	
Magnitude Differential Input	V _{ID}	0.2		0.6	V	
Common Mode Voltage	RxVCM	1.0	1.2	1.4	V	
LVDS Digital Operating Current	I _{ddlvs}	-	40	50	mA	Fclk=65MHz VDD=3.3V
LVDS Digital Stand-by Current	I _{stlvs}	-	10	50	uA	Clock & all function are stopped

Note 1 : Test Condition: VDD=3.3V ; Test Pattern: Black.

Note 2 : RxVTH and RxVTL is defined in RxIN0+/- · RxIN1+/- · RxIN2+/- · RxIN3+/- · RxCLK+/- signal voltage level.

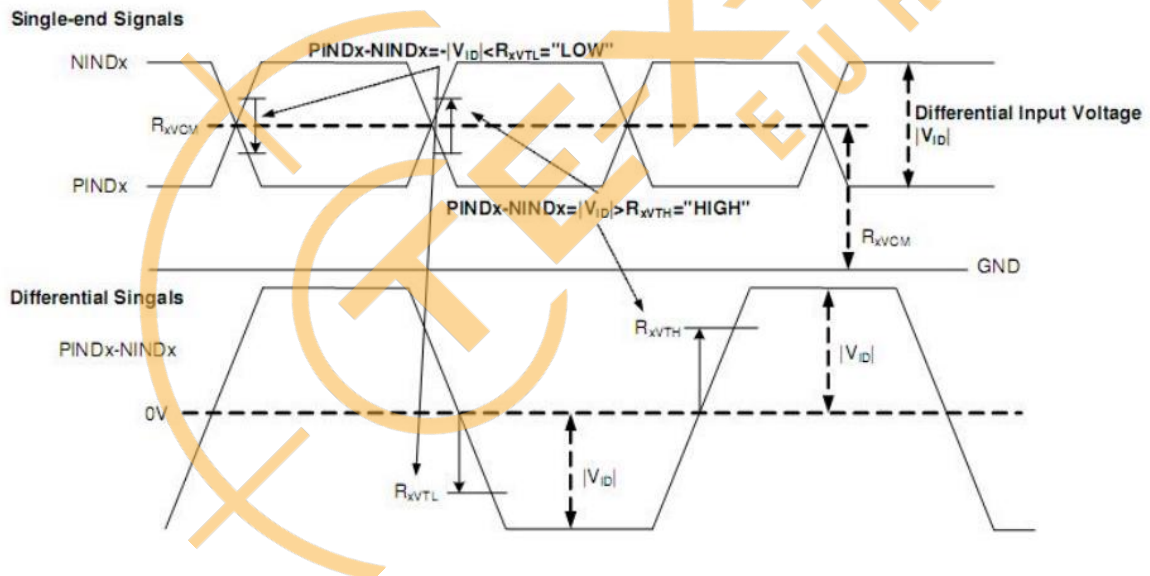

7.2 AC Electrical Characteristics

ITEM	SYMBOL	MIN.	TYP.	MAX.	UNIT	REMARK
Clock Frequency	R _{XFCLK}	20	-	80	MHz	
Input data skew margin	T _{RSKM}	500	-	-	ps	VID =400mV R _{XVCM} =1.2V R _{XFCLK} =80MHz
Clock High time	T _{LVCH}	-	4/7	-	R _{XFCLK}	
Clock Low time	T _{LVCL}	-	3/7	-	R _{XFCLK}	
PLL wake-up time	T _{enPLL}	-	10	150	us	

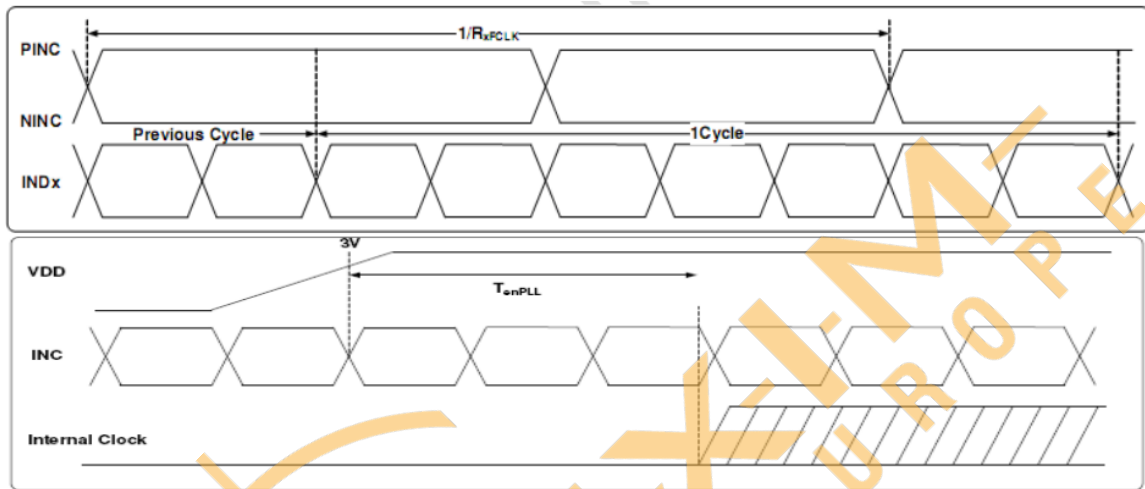
7.3 BACKLIGHT UNITS

Ta=25°C

ITEM	SYMBOL	MIN.	TYP.	MAX.	UNIT	REMARK
LED Driving Voltage	V _{LED}	-	5	-	V	
LED Driving Current	I _{LED}	-	(300)	-	mA	
LED Life Time	-	-	30000	-	Hrs	Note1

Note 1: The LED life time define as the estimated time to 50% degradation of initial luminous.

7.4 CTP ELECTRICAL CHARACTERISTICS

ITEM	SYMBOL	MIN.	TYP.	MAX.	UNIT	REMARK
Power Voltage For PCAP	V _{CC}	/	3.3	/	V	

8. OPTICAL CHARACTERISTICS

8.1 Optical specification

Ta=25°C

ITEM	SYMBOL	CONDITIONS	MIN.	TYP.	MAX.	UNIT	REMARK	
Contrast Ratio	CR	Viewing Normal Angle $\Theta=0$	600	800	-	-	Left/right 0° Top/Bottom 5°	
Response Time @25°C	TR/TF		-	35	40	ms	Note 1,4	
Color Chromaticity (CIE1931)	White		Wx	-0.05	0.306	+0.05		Note 1,5
			Wy		0.329			
	Red		Rx		0.570			
			Ry		0.330			
	Green		Gx		0.350			
			Gy		0.592			
	Blue		Bx		0.155			
			By		0.101			
Viewing Angle	Hor.	θ_L	80	88	-	Deg.	Note 2	
		θ_R	80	88	-			
	Ver.	θ_U	80	88	-			
		θ_D	80	88	-			
Luminance(Center)	YL		320	400	-	cd/m ²	Note 7	
Luminance Uniformity	BUNI		70	75	-	%	Note 1,6	
NTSC			45	50	-	%		

Note (1) Definition of optical measurement system.

The optical characteristics should be measured in dark room. After 10Minutes operation, the optical properties are measured at the center point of the LCD screen. All input terminals LCD panel must be ground when measuring the center area of the panel.

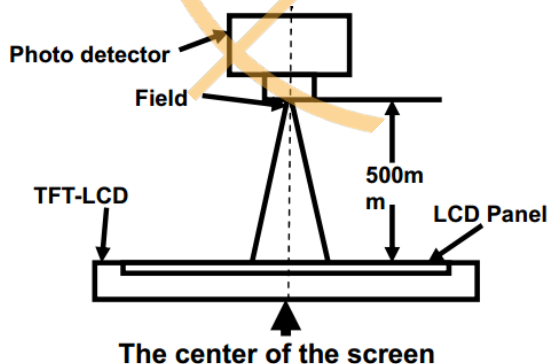

Item	Photo detector	Field
Contrast Ratio	SR-3A	1°
Luminance		
Chromaticity		
Lum Uniformity	BM-7A	2°
Response Time		

Note(2) Definition of viewing angle range and measurement system.

Viewing angle is measured at the center point of the LCD by CONOSCOPE(ergo-80)

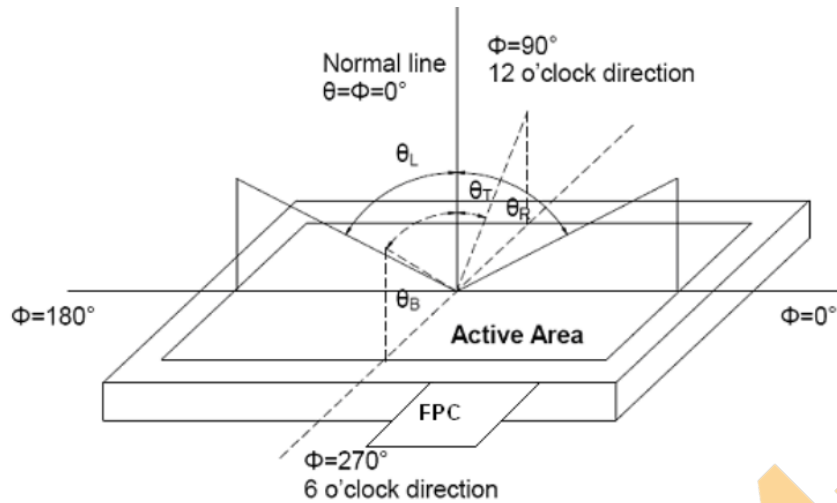

Note(3) Definition of contrast ratio

$$\text{Contrast ratio (CR)} = \frac{\text{Luminance measured when LCD is on the "White" state}}{\text{Luminance measured when LCD is on the "Black" state}}$$

"White state": The state is that the LCD should drive by V_{white} .

"Black state": The state is that the LCD should drive by V_{black} .

V_{white} : To be determined V_{black} : To be determined.

Note(4) Definition of Response time

The response time is defined as the LCD optical switching time interval between "White" state and "Black" state. Rise time (T_{ON}) is the time between photo detector output intensity changed from 90% to 10%. And fall time (T_{OFF}) is the time between photo detector output intensity changed from 10% to 90%.

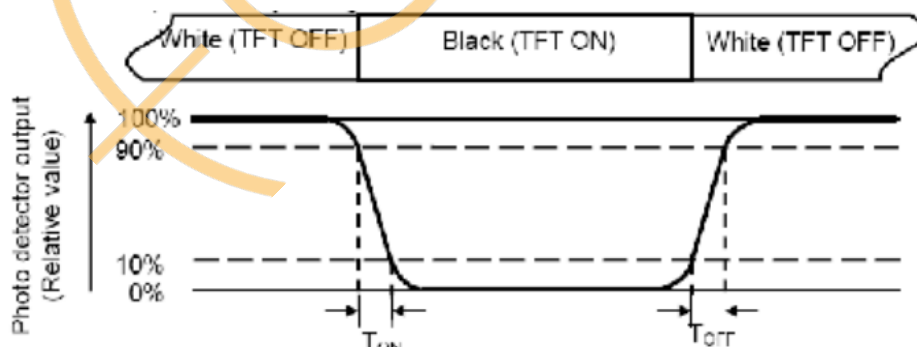

Note (5) Definition of color chromaticity (CIE1931)
Color coordinates measured at center point of LCD.

Note (6) Definition of Luminance Uniformity
Active area is divided into 9 measuring areas(Refer Fig. 2).Every measuring point is placed at the center of each measuring area.
Luminance Uniformity(U) = L_{min} / L_{max}
L-----Active area length W----- Active area width

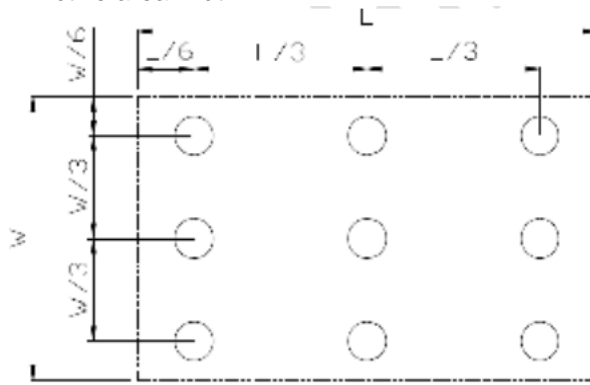

L_{max} : The measured Maximum luminance of all measurement position.
 L_{min} : The measured Minimum luminance of all measurement position.

Note (7) Definition of Luminance:
Measure the luminance of white state at center point.

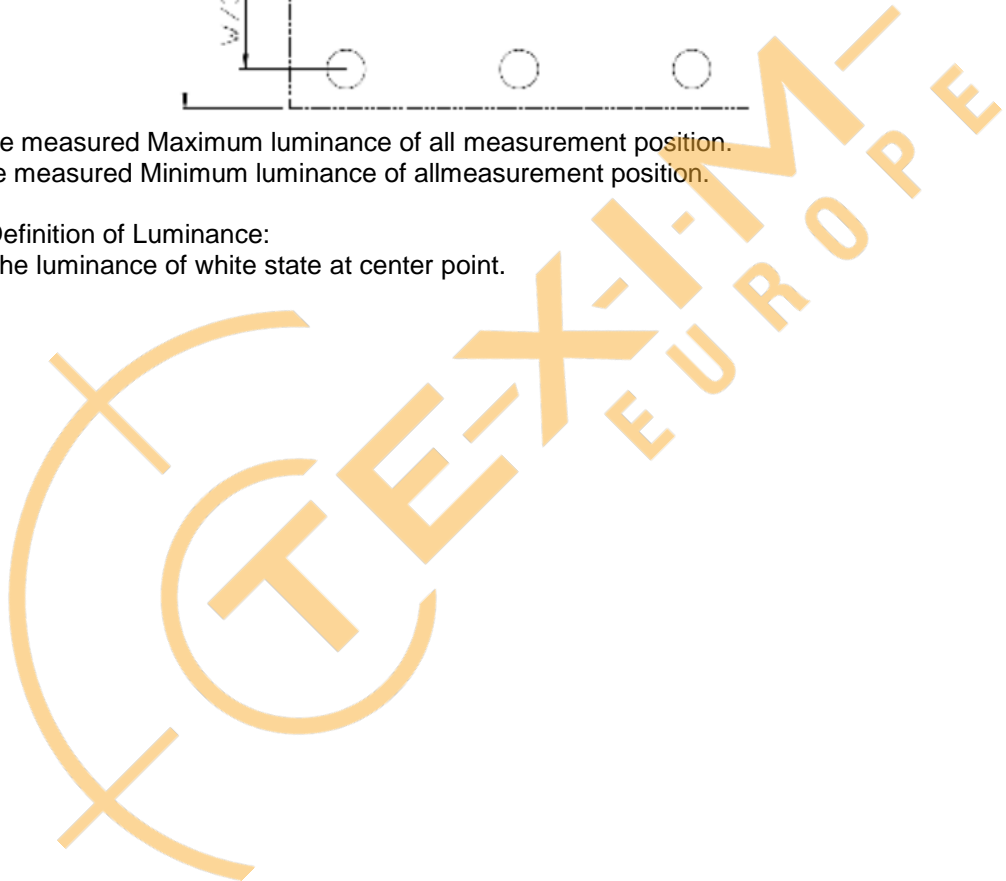

9. TOUCH PANEL SPECIFICATIONS

9.1 Type :

9.1.1 IIC I/F PCAP with EETI Touch Control Board

9.2 STRUCTURE :

9.2.1 Thickness : Thickness : 2.0±0.2mm

9.2.2 Thickness : 2.0mm (Cover 1.1t / Sensor 0.7t / OCA 0.1)

9.2.3 Control Board Dimension : 28.6 x 18.0 mm

9.3 IC MODEL :

9.3.1 IC manufacture : EETI

9.3.2 IC part number : EE80H321829

9.3.3 Interface : IIC

9.4 ELECTRICAL CHARACTERISTICS :

9.4.1 Operating Voltage : +3.3V

9.5 MECHANICAL CHARACTERISTICS :

9.5.1 Surface hardness : 6H

9.6 OPTICAL CHARACTERISTICS :

9.6.1 Transparency : $\geq 85\%$

9.6.2 Haze:TBD



10. TIMING SPECIFICATIONS

10.1 Input Time

ITEM	SYMBOL	MIN.	TYP.	MAX.	UNIT	NOTE
DCLK frequency	tCLK	62.6	68.2	78.1	MHz	
Horizontal blanking time	tHBT	20	69	164	tCLK	tHBP + tHFP
Horizontal back porch	tHBP	5	5	164-tHFP	tCLK	
Horizontal display area	tHD	1280	1280	1280	tCLK	
Horizontal front porch	tHFP	15	64	159	tCLK	
Horizontal period	tH	1300	1349	1444	tCLK	
Horizontal pulse width	tHPW	1	1	256	tCLK	
Vertical blanking time	tVBT	5	42	101	tH	tVBP + tVFP
Vertical back porch	tVBP	2	2	101-tVFP	tH	
Vertical display area	tVD	800	800	800	tH	
Vertical front porch	tVFP	3	40	99	tH	
Vertical period	tV	803	842	901	tH	
Vertical pulse width	tVPW	1	1	128	tH	

10.2 Data Input Format VESA data mapping



Note 1: for 6 bit mode, MSB are R/G/B[5] and R/G/B[0] are LSB

Note 2: for 8 bit mode, MSB are R/G/B[7] and R/G/B[0] are LSB

10.3 Power Sequence

Power OFF:

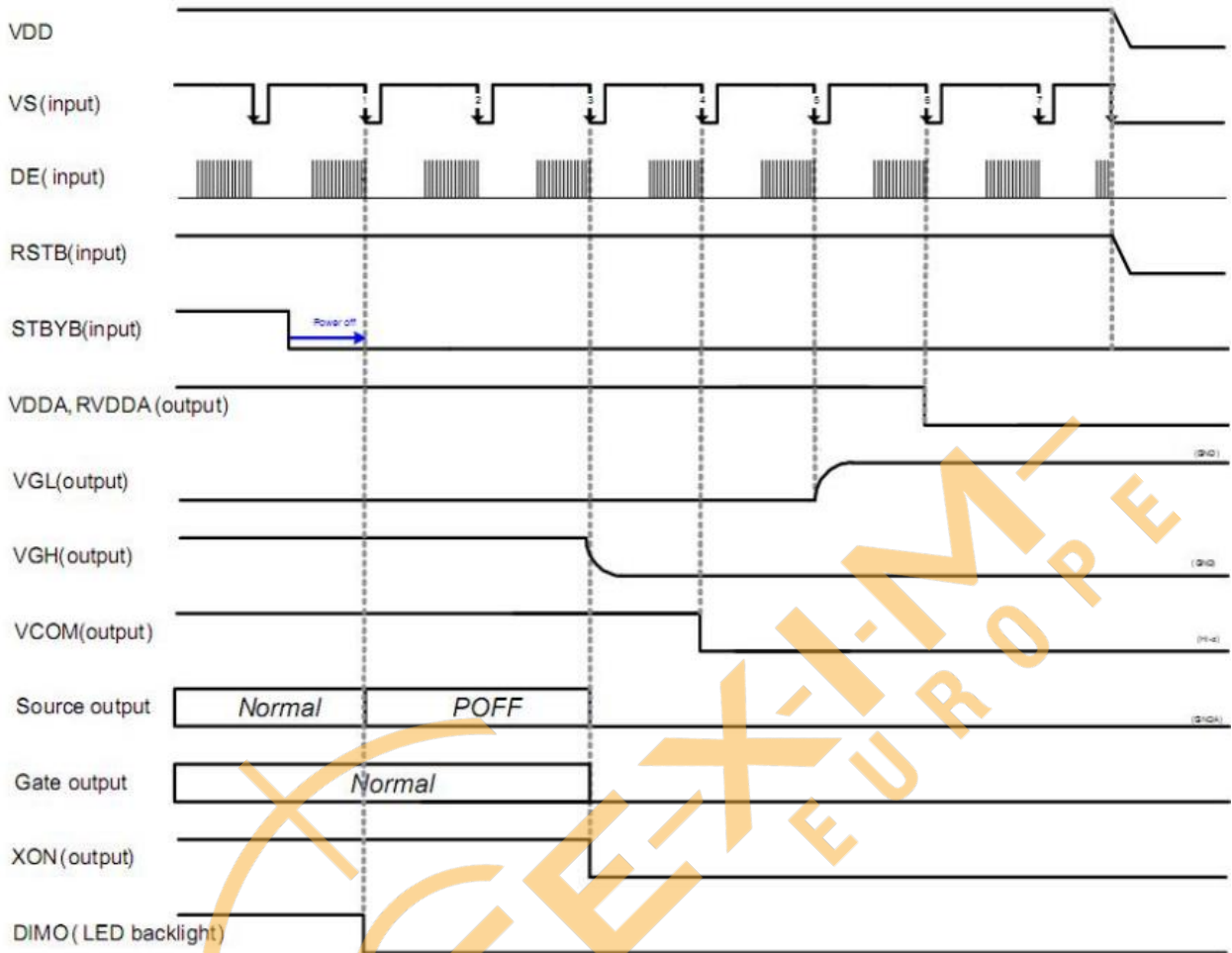

Power ON:

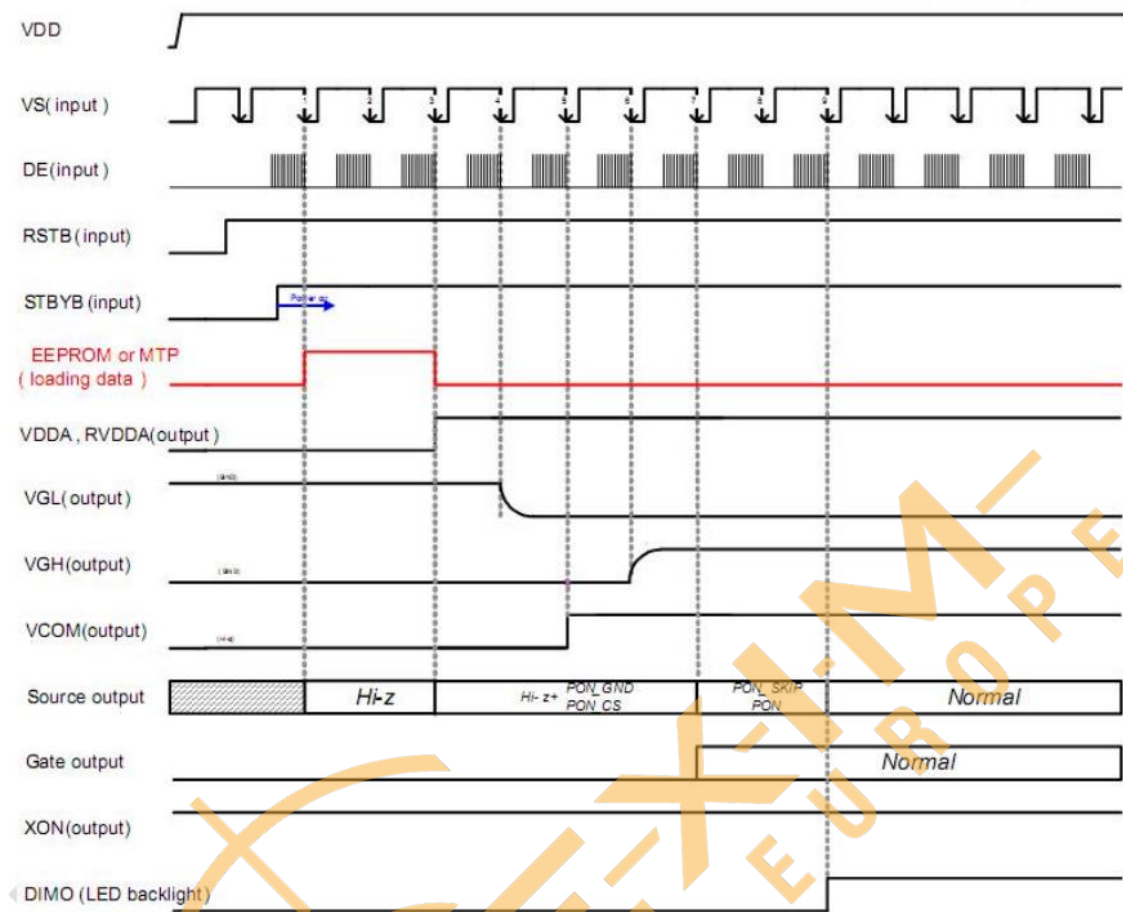

11. RELIABILITY TEST

ENVIRONMENTAL TEST				
NO.	ITEM	CONDITIONS	TIME PERIOD	REMARK
1	High Temperature Storage	Ta= 80°C	240Hours	1,2,3,4
2	Low Temperature Storage	Ta= -30°C	240Hours	1,2,3,4
3	High Temperature Humidity Storage	60°C,90%RH	240Hours	1,2,3,4
4	High Temperature Operation	Ts= 70°C	240Hours	1,2,3,4
5	Low Temperature Operation	Ta= -20°C	240Hours	1,2,3,4,5
6	Temperature Cycle	-30°C~80°C	20 CYCLES	1,2,3

Note 1 : There is no display function NG issue occurred, all the cosmetic specification is judged before the reliability stress.

Note 2 : All of the function & cosmetic judgment basis base on IIS Spec. at room temperature. (The tested module must have enough recovery time at least 2 hours at room temperature.)

Note 3 : The test condition definition panel's surface temperature.

Note 4 : After 1000 hours test has been done, the specimen should function normally without any fatal defect. (no picture, line defect, out of synchronization)

Note 5 : Short time operation between -40~30°C doesn't provide full performance but a correct image on the LCD. The LCD is guaranteed to suffer no permanent damage.

12. PRECAUTIONS FOR USE

12.1 SAFETY

- (1) Do not swallow any liquid crystal, even if there is no proof that liquid crystal is poisonous.
- (2) If the LCD panel breaks, be careful not to get liquid crystal to touch your skin.
- (3) If skin is exposed to liquid crystal, wash the area thoroughly with alcohol or soap.

12.2 STORAGE CONDITIONS

- (1) Store the panel or module in a dark place where the temperature is $23\pm 5^{\circ}\text{C}$ and the humidity is below $50\pm 20\%\text{RH}$.
- (2) Store in anti-static electricity container.
- (3) Store in clean environment, free from dust, active gas, and solvent.
- (4) Do not place the module near organics solvents or corrosive gases.
- (5) Do not crush, shake, or jolt the module.

12.3 HANDLING PRECAUTIONS

- (1) Avoid static electricity which can damage the CMOS LSI.
- (2) The polarizing plate of the display is very fragile. So, please handle it very carefully.
- (3) Do not give external shock.
- (4) Do not apply excessive force on the surface.
- (5) Do not wipe the polarizing plate with a dry cloth, as it may easily scratch the Surface of plate.
- (6) Do not use ketonic solvent & Aromatic solvent, use with a soft cloth soaked with a cleaning naphtha solvent.
- (7) Do not operate it above the absolute maximum rating.
- (8) Do not remove the panel or frame from the module.
- (9) When the module is assembled, it should be attached to the system firmly, Be careful not to twist and bend the module.
- (10) Wipe off water droplets or oil immediately . If you leave the droplets for a long time, staining and discoloration may occur.
- (11) If the liquid crystal material leaks from the panel, it should be kept away from the eyes or mouth. In case of contact with hands, legs or clothes, it must be washed away thoroughly with soap.

12.4 WARRANTY

- (1) Acceptance inspection period. The period is within one month after the arrival of contracted commodity at the buyer's factory site.
- (2) Applicable warrant period. The period is within 12 months since the date of shipping out under normal using and storage conditions.

The Netherlands



Elektrostraat 17
NL-7483 PG Haaksbergen

T: +31 (0)53 573 33 33
F: +31 (0)53 573 33 30
E: nl@texim-europe.com

Belgium



Zuiderlaan 14 bus 10
B-1731 Zellik

T: +32 (0)2 462 01 00
F: +32 (0)2 462 01 25
E: belgium@texim-europe.com

UK & Ireland



St. Mary's House, Church Lane
Carlton Le Moorland
Lincoln LN5 9HS

T: +44 (0)1522 789 555
F: +44 (0)845 299 22 26
E: uk@texim-europe.com

Germany North



Bahnhofstrasse 92
D-25451 Quickborn

T: +49 (0)4106 627 07-0
F: +49 (0)4106 627 07-20
E: germany@texim-europe.com

Germany South



Martin-Kollar-Strasse 9
D-81829 München

T: +49 (0)89 436 086-0
F: +49 (0)89 436 086-19
E: germany@texim-europe.com

Austria



Warwitzstrasse 9
A-5020 Salzburg

T: +43 (0)662 216 026
F: +43 (0)662 216 026-66
E: austria@texim-europe.com

Nordic region



Sdr. Jagtvej 12
DK-2970 Hørsholm

T: +45 88 20 26 30
F: +45 88 20 26 39
E: nordic@texim-europe.com

Italy



Via Matteotti 43
IT-20864 Agrate Brianza (MB)

T: +39 (0)39 971 3293
F: +39 (0)39 971 3293
E: italy@texim-europe.com

General information



info@texim-europe.com
www.texim-europe.com