



---

---

## Product Specification

Part Name: 2.40 inch TFT Display Module

Customer Part ID:

Topovision Part ID: TVT0240H4-I (IPS)

Ver: A

Customer:
Approved by

From: Topovision Technology Co., Ltd.
Approved by

Notes:

1. Please contact Topovision Technology Co., Ltd. before assigning your product based on this module specification
2. The information contained herein is presented merely to indicate the characteristics and performance of our products. No responsibility is assumed by Topovision Technology Co., Ltd. for any intellectual property claims or other problems that may result from application based on the module described herein.

## Contents

<b>REVISION HISTORY</b> .....	<b>3</b>
<b>1. GENERAL DESCRIPTION</b> .....	<b>4</b>
1.1 DESCRIPTION.....	4
1.2 GENERAL INFORMATION.....	4
<b>2. ABSOLUTE MAXIMUM RATING</b> .....	<b>5</b>
<b>3. ELECTRICAL CHARACTERISTICS</b> .....	<b>5</b>
<b>4. OPTICAL CHARACTERISTICS</b> .....	<b>6</b>
<b>5. MODULE OUTLINE DIMENSION</b> .....	<b>9</b>
<b>6. MODULE INTERFACE DESCRIPTION</b> .....	<b>11</b>
<b>7. REFERENCE APPLICATION CIRCUIT</b> .....	<b>11</b>
<b>8. RELIABILITY TEST CONDITIONS</b> .....	<b>11</b>
<b>9. PACKING</b> .....	<b>12</b>
<b>10. INSPECTION CRITERION</b> .....	<b>13</b>
<b>11. GENERAL PRECAUTIONS</b> .....	<b>17</b>

## Revision History

Rev.	Date	Contents	Written	Approved
A	2019/02/19	Preliminary Specification	MA	YUAN

### Special Notes

Note1.	

## 1. GENERAL DESCRIPTION

### 1.1 DESCRIPTION

TVT0240H4-I is a transmissive type color active matrix TFT (Thin Film Transistor) liquid crystal display (LCD) that uses amorphous silicon TFT as a switching device. This model is composed of a TFT-LCD module (TFT-LCD panel, driver IC and FPC), a back-light unit and. The resolution of 2.4" contains 240X320RGB pixels and can display up to 16.7M colors.

### 1.2 GENERAL INFORMATION

NO.	Item	Contents	Unit
1	LCD Size	2.4 inch(Diagonal)	-
2	Display Mode	Normally black	-
3	Resolution	240(H)RGB x 320(V)	-
4	Dot pitch	0.153(H) x 0.153(V) mm	-
5	Active area	36.72(H) x 48.96(V) mm	-
6	Module size	40.44(H) x 57.0(V) x2.2 (D) mm	-
7	Color arrangement	RGB Vvertical stripe	-
8	Interface	8 BIT 8080 MCU	-
9	Drive IC	ST7789V2	-
10	Luminance(cd/m2)	450 (TYP)	
11	Viewing Direction	All View	
12	Backlight	4 White LED	
13	Operating Temp.	-20°C~ + 70°C	°C
14	Storage Temp.	-30°C~+ 80°C	°C
15	Weight	TBD	g

## 2. ABSOLUTE MAXIMUM RATING

( $T_a=25\pm 2^\circ\text{C}$ ,  $V_{ss}=\text{GND}=0\text{V}$ )

Parameter	Symbol	Min	Max	Unit	Notes
Supply Voltage (I/O)	VDD	-0.3	4.6	V	
Analog Supply Voltage	VDDIO	-0.3	4.6	V	
Logic Input Voltage	VIN	-0.3	VDD+0.3	V	
Operation Temperature	Top	-20	70	$^\circ\text{C}$	
Storage Temperature	Tst	-30	80	$^\circ\text{C}$	

## 3. ELECTRICAL CHARACTERISTICS

( $T_a=25\pm 2^\circ\text{C}$ )

Parameter	Symbol	Min	TYP	MAX	Unit	Notes
Voltage for LED backlight	$V_{bl}$	2.9	3.0	3.1	V	
Supply Voltage for Logic	VDD	2.4	2.8	3.3	V	
Interface Operation Voltage	VDDIO	1.65	1.8	3.3	V	
Gate Driver High Voltage	VGH	12.2	-	14.97	V	
Gate Driver Low Voltage	VGL	-12.5	-	-7.16	V	
Operating Current for $V_{DD}$	$I_{DD}$	--	8	10	mA	
Current for LED backlight	$I_{bl}$		20	-	mA	1 LED
Brightness	$L_{br}$	380	450	--	$\text{cd}/\text{m}^2$	
Sleep In Mode VDD	$I_{dd}$	--	15	30	$\mu\text{A}$	
Sleep In Mode VDDIO	$I_{ddio}$	--	5	10	$\mu\text{A}$	

1 Test condition is:

- a: Center point on active area
- b: Best Contrast

2 Uniform measure condition:

- a: Measure 9 point, Measure location is show below:
- b: Uniform = (Min brightness/Max.brightness)x100%
- c: Best Contrast.

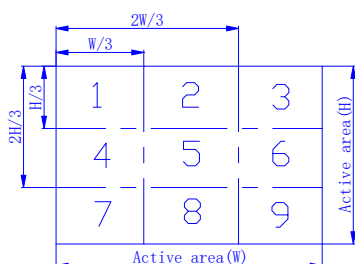

## 4. OPTICAL CHARACTERISTICS

The following items are measured under stable conditions. The optical characteristics should be measured in a dark room.

Measuring equipment: BM-5AS, BM-7, EZ-Contrast.

( $T_a=25\pm 2^\circ\text{C}$ )

Item	Symbol	Measuring Conditions		Min.	Typ.	Max.	Unit	Remark
		$\theta = 0^\circ$ $\phi = 0^\circ$	25 °C					
Response Time	Tr+Tf	$\theta = 0^\circ$ $\phi = 0^\circ$	25 °C	-	35	45	ms	Note4 BM-5AS
Viewing Angle	$\theta$	$\phi = 0^\circ$	25 °C	-	80	-	Deg	EZ Contrast Note(6)
		$\phi = 180^\circ$	25 °C	-	80	-		
	$\theta$	$\phi = 90^\circ$	25 °C	-	80	-		
		$\phi = 270^\circ$	25 °C	-	80	-		
Contrast Ratio	CR	-	25 °C	640	800	-	-	Note2 BM-7
Color of CIE Coordinate	White	X	25 °C	-0.02	0.310	+0.02	-	BM-7 Note(5)
		Y	25 °C		0.336			
	Red	X	25 °C		0.647			
		Y	25 °C		0.317			
	Green	X	25 °C		0.275			
		Y	25 °C		0.582			
	Blue	X	25 °C		0.140			
		Y	25 °C		0.088			
Transmittance (with polarizer)					4.65		%	

\* This condition will be changed by the evaluation circumstance. If product is exposed to high temperatures for extended time, there is a possibility of the polarizer film damage which could degrade the optical characteristics.

Notes:

- (1) Test Equipment Setup: After stabilizing and leaving the panel alone at a given temperature for 30min, the measurement should be executed. Measurement should be executed in a stable, windless, and dark room 30min after lighting the back-light. This should be measured in the center of screen.

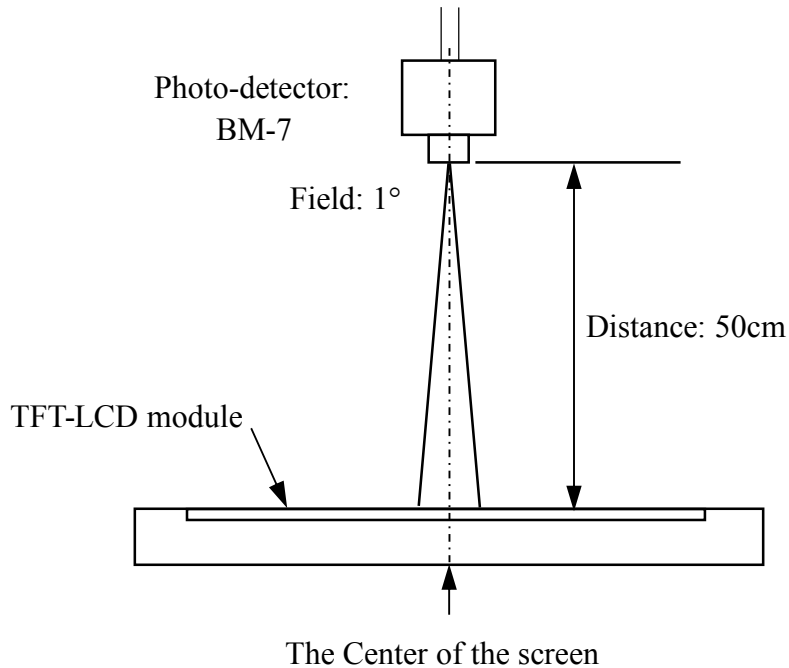

- (2) Definition of Contrast Ratio (CR):

$$\text{Contrast Ratio (CR)} = \frac{\text{Luminance measured when LCD on the "white" state}}{\text{Luminance measured when LCD on the "black" state}}$$

- (3) Definition of Luminance Uniformity: Active area is divided into 9 measuring areas (Shown in below), every measuring point is placed at the center of each measuring area.

$$\text{Luminance Uniformity} = \frac{\text{Min Luminance of white among 9-points}}{\text{Max Luminance of white among 9-points}} \times 100\%$$

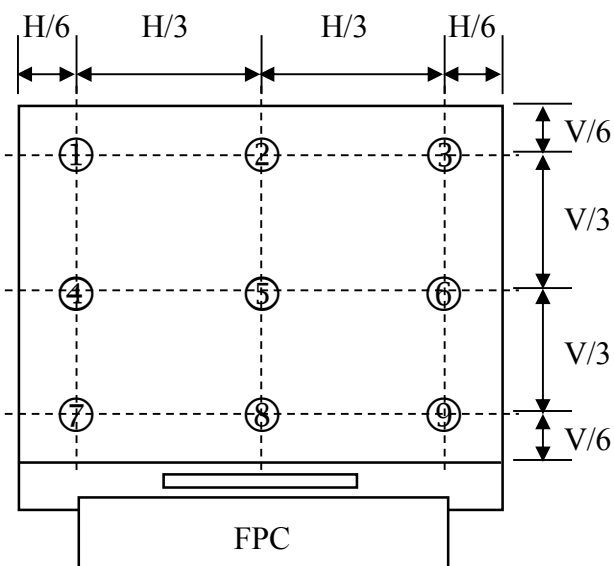

The spot locations for luminance measurement

- (4) Definition of Response time: Sum of  $T_r$  and  $T_f$ .

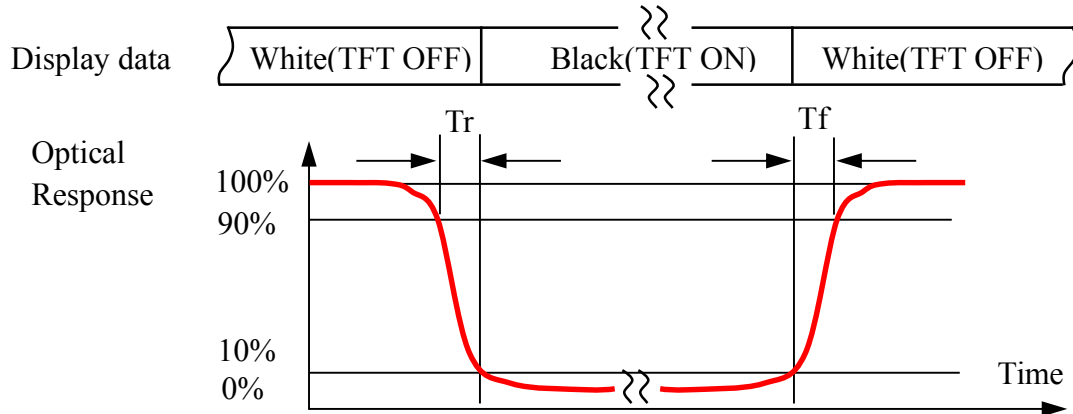

- (5) Definition of Viewing Angle: The viewing angle range that the  $CR \geq 10$ .

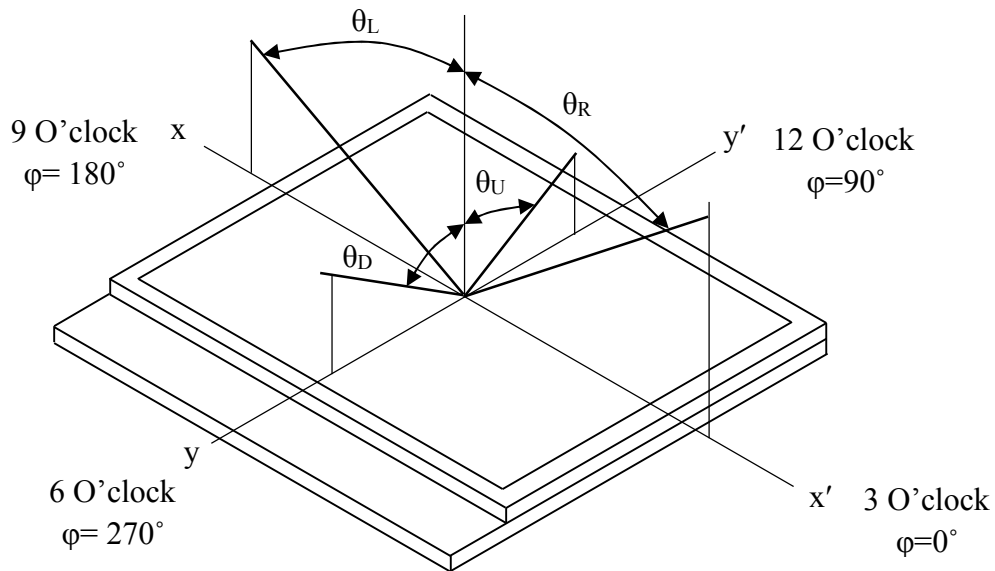

- (6) Definition of Color Chromaticity (CIE 1931)  
Color coordinate of white & red, green, blue at center point.
- (7) The different Rubbing Direction will cause the different optima view direction.



# 5. MODULE OUTLINE DIMENSION

Item	Date	Remark
A	20181229	Original Drawing

NO	SYMBOL
1	LED-A
2	LED-K
3	TE
4	DB7
5	DB6
6	DB5
7	DB4
8	DB3
9	DB2
10	DB1
11	DB0
12	GND
13	RD
14	WR
15	RS
16	CS
17	RESET
18	GND
19	IOVCC
20	VDD
21	GND
22	NC
23	NC
24	NC

FPC弯折示意图  
FPC弯折出货

FPC弯折突出背光胶框  
请注意机壳避让

CUSTOMER APVL	CUSTOMER	DATE	TITLE
			LCM OUTLINE DIMENSION
DRAWN	SCALE	UNIT	mm
DFTG CHK			
ENGR CHK			
APPROVAL			
			MODEL
			TVT0240H4-I
			DWG NO
			1/1

**Support 8BIT Parallel**

IF=80mA, VF=2.9~3.1V  
LED CIRCUIT DIAGRAM:

**NOTES:**

- DISPLAY TYPE: 2.4" IPS TFT
- VIEWING DIRECTION: ALL
- POLARIZER MODE: TRANSMISSIVE/NORMALLY WHITE
- DRIVER IC: S17789V2
- OPERATING TEMP.: -20° C~70° C
- STORAGE TEMP.: -30° C~80° C
- BACK LIGHT: 4 CHIP-WHITE LED
- LCM Luminance: 450 CD/M<sup>2</sup>(TYP)
- UNMARKED TOLERANCE: ±0.2
- 建议机壳开窗可视区比 LCD A.A区单边大 0.3mm**
- 产品符合RoHS标准

## 6. MODULE INTERFACE DESCRIPTION

FPC Connector is used for the module electronics interface.

NO.	Symbol	Description
1	LEDA	LED Anode
2	LEDK	LED Canthode
3	TE	Tearing effect signal is used to synchronize MCU to frame memory writing.
4	DB7	MCU parallel interface data
5	DB6	MCU parallel interface data
6	DB5	MCU parallel interface data
7	DB4	MCU parallel interface data
8	DB3	MCU parallel interface data
9	DB2	MCU parallel interface data
10	DB1	MCU parallel interface data
11	DB0	MCU parallel interface data
12	GND	Power Ground.
13	RD	Read MCU parallel interface
14	WR	Write enable in MCU parallel interface.
15	RS	Display data/command selection pin in 4-line serial interface.
16	CS	Chip selection pin, Low enable, High disable.
17	RESET	This signal will reset the device, Signal is active low.
18	GND	Power Ground.
19	IOVCC	Power Supply for I/O system. IOVCC=1.65V-3.3V
20	VDD	Power Supply for Analog
21	GND	Power Ground.
22	NC	No Connect.
23	NC	No Connect.
24	NC	No Connect.

## 7. REFERENCE APPLICATION CIRCUIT

Please consult our technical department for detail information.

## 8. RELIABILITY TEST CONDITIONS

No.	Test Item	Test Condition	Notes
1	High Temperature Storage	+80°C / 120H	Inspection after 2~4h storage at room temperature, the sample shall be free from defects: 1. Air bubble in the LCD; 2. Seal leak; 3. Non-display; 4. Missing segments; 5. Glass crack; 6. The surface shall be free from damage. 7. The electrical characteristics requirements shall be satisfied.
2	Low Temperature Storage	-30°C / 120H	
3	High Temperature Operating	+70°C / 120H	
4	Low Temperature Operating	-20°C / 120H	
5	Temperature Cycle	-20±2°C↔25°C↔+70±2°C x 10cycles (30min) (5min) (30min)	
6	High Temperature /Humidity storage	50+5°C x 90%RH / 120H	
7	Vibration Test	Frequency: 10Hz~55Hz~10Hz Amplitude:1.5mm, 2 hours for each direction of X, Y, Z	
8	Packing Drop Test	Drop to the ground from 1m height, 1 corner, 3 edges, 6 surfaces.	
9	ESD test	Voltage:±8KV R: 330Ω C: 150pF Air discharge, 10time	

### Remarks:

- (1) The test samples should be applied to only one test item.
- (2) Sample size for each test item is 5~10pcs.
- (3) For High Temperature/Humidity storage test, pure water (resistance>10MΩ) should be used.
- (4) In case of malfunction defect caused by ESD damage, if it would be recovered to normal state after resetting, it would be judge as a good part.
- (5) Failure judgment criterion: basic specification, electrical characteristic, mechanical characteristic, optical characteristic.

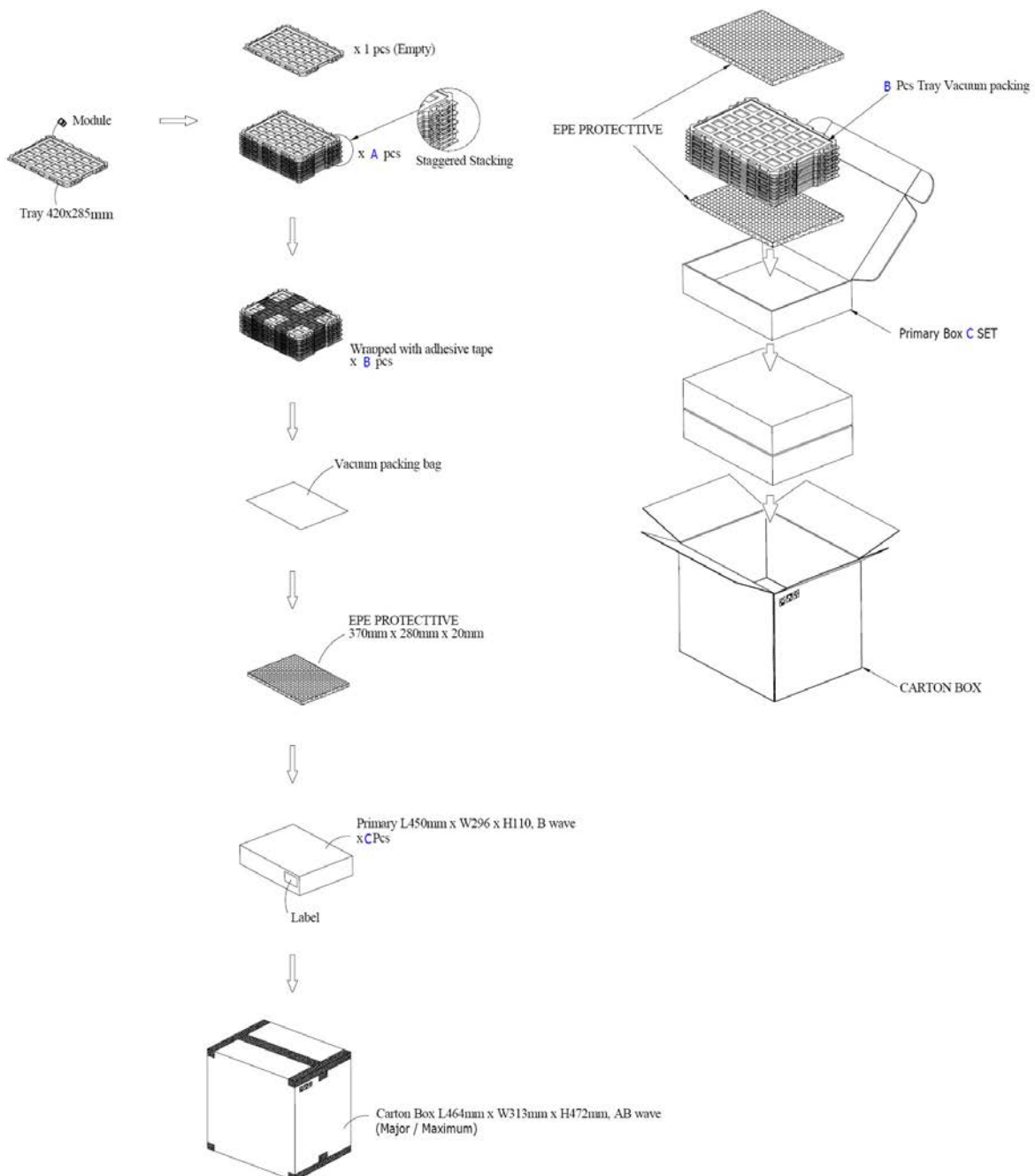

## 9. PACKING SPECIFICATION

Item	Quantity		
<b>Module</b>	<b>XXX</b>	<b>per Primary Box</b>	
<b>Holding Trays (A)</b>	<b>15</b>	<b>per Primary Box</b>	
<b>Total Trays (B)</b>	<b>16</b>	<b>per Primary Box (Including 1 Empty Tray)</b>	
<b>Primary Box (C)</b>	<b>1~4</b>	<b>per Carton (4 as Major / Maximum)</b>	

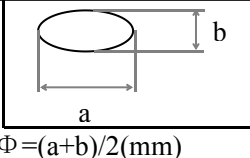
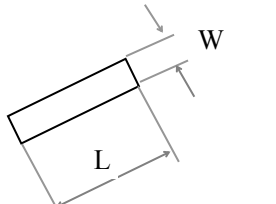
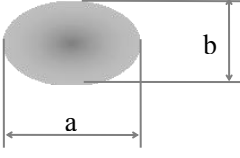

## 10. INSPECTION CRITERION

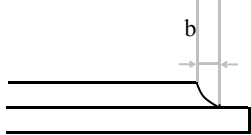
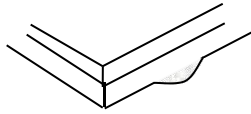
Inspection item		Judgement standard				
		Category		Acceptable number		
				A zone	B zone	
1	Black spot, White spot, Bright Spot, Pinhole Foreign Particle, Bubble and Particle Between polarizer and glass, scratch on polarizer		A B C D	$\Phi \leq 0.10$ $0.10 < \Phi \leq 0.30$ $0.30 < \Phi$	Ignored 2 0	Ignored
			Total defective point(B,C)		2	
	Bright spot			$0.15 < \Phi \leq 0.20$	$N \leq 0$	Ignored
	Dark spot/ Black spot			$0.15 < \Phi \leq 0.20$	$N \leq 2$	
	Attached to the two pixels are bright spots			$0.15 < \Phi \leq 0.20$	$N \leq 0$	
	Even a two pixel is dark			$0.15 < \Phi \leq 0.20$	$N \leq 0$	
Pixel total number			$0.15 < \Phi \leq 0.20$	$N \leq 2$		
	Note1: the spot defect caused by foreign matter is judged according to the defect of the foreign body. Note 2: when the light is not wired to show the type of defects.					
2	Black line, White line, Bubble and Particle Between Polarizer and glass, Scratch on polarizer		A B C D	$W \leq 0.01$ $0.01 < W \leq 0.03 \quad L \leq 3.0$ $0.03 < W \leq 0.05 \quad L \leq 3.0$ $0.05 < W$	Ignored 2 1 0	Ignored
		W:Width, L:Length(mm)	Total defective point(B,C)		2	
3	Contrast variation		A B C	$\Phi \leq 0.1$ $0.1 < \Phi \leq 0.3$ $0.3 < \Phi$	Ignored 2 0	Ignored
			Total defective point(B,C)		2	
4	Bubble inside cell			any size	none	none
5	Polarizer defect (if Polarizer is used)	Scratch and damage on polarizer, particle on polarizer or between polarizer and glass.	Refer to item 1 and item 2.			
		Bubble, dent and convex	A B C	$\Phi \leq 0.1$ $0.1 < \Phi \leq 0.2$ $0.3 < \Phi$	Ignored 2 0	Ignored
		Total defective point(B,C)		2		

Inspection item		Judgement standard		
		Category	Acceptable number	
			A zone	B zone
6	Surplus glass	①Stage surplus glass 	$b \leq 0.3\text{mm}$	
		②Surrounding surplus glass 	Should not influence outline dimension and assembling.	
7	MURA	①MURA	Naked eye examination: red, green, blue screen does not allow the appearance, black screen requires visual is not obvious, the specific reference limit samples. Note: the principle of closing the sample is to be installed on the whole machine and the end user will not find it in the normal usage scenario. Inspection basis: 6%ND (MURA mainly in the black screen and indoor light is relatively dark will be found, it is recommended to turn off the indoor lighting inspection.)	
		②Point Black / White / point(MURA)  	1, under the black / gray screen check: $D \leq 0.10\text{mm}$ Ignored; $0.10\text{mm} < D \leq 0.3\text{mm}$ , $N \leq 2$ ; $D > 0.3\text{mm}$ : Unqualified. 2, switch to the red, green, blue in which any one of the screen appears black or white or point to point white or point of failure. 	

Inspection item		Judgment standard	
		Category(application: B zone)	
8	Glass defect crack	①The front of lead terminals 	A   If $a \leq t$ and $b \leq 1.0$ , $c$ is not limited B   $a \leq t$ , $1 \leq b \leq 2\text{mm}$ , $c \leq 3\text{mm}$ C   If glass crack cover alignment mark, $b \leq 0.5\text{mm}$ . D   Crack at two sides of lead terminals should not cover patterns and alignment mark
		②Surrounding crack—non-contact side 	$b <$ Inner borderline of the seal
		③ Surrounding crack— contact side 	$b <$ Outer borderline of the seal
		④Corner 	A   $a \leq t$ , $b \leq 3.0$ , $c \leq 3.0$ *Glass crack should not cover patterns used for

Inspection item		Judgement standard	
9	FPC defect	<p>Component soldering: No cold soldering, short/open circuit, burr, tin ball.</p> <p>The flat encapsulation component position deviation must be less than 1/2 width of the pin (Pic.1);</p> <p>The sheet component deviation: pin deviates from the pad and contact with the near components is not permitted (Pic.2)</p>	<p>Component</p> <p><math>L \leq W/2</math></p> <p><math>W</math></p>
		<p>lead defect:</p> <p>The lead lack must be less than 1/2 of its width;</p> <p>The lead burr must be less than 1/2 of the seam;</p> <p>Impurities connect with the near leads is not permitted</p>	<p>Soldering pad</p> <p>Lead</p> <p>Component</p> <p><math>L1 &gt; 0</math></p> <p><math>L2 &gt; 0</math></p>
		<p>Connector soldering:</p> <p>Soldering tin is at contact position of the plug and socket is not permitted</p> <p>No foundation is scald</p> <p>Serious cave distortion on plug and socket contact pin is not permitted</p>	<p>head</p> <p>Base Board</p> <p>Soldering tin is not permit in this area</p> <p>Soldering tin is not permit in this area</p> <p>socket</p> <p>Base Board</p>



## 11. GENERAL PRECAUTIONS

### 1.1 HANDLING

- (1) When the module is assembled, it should be attached to the system firmly. Be careful not to twist and bent the module.
- (2) Refrain from strong mechanical shock and / or any force to the module. In addition to damage, this may cause improper operation or damage to the module and back-light unit.
- (3) Note that display modules are very fragile and could be easily damaged. Do not press or scratch the surface harder than a HB pencil lead.
- (4) Wipe off water droplets or oil immediately. If you leave the droplets for a long time, straining and discoloration may occur.
- (5) If the display module surface becomes contaminated, breathe on the surface and gently wipe it with a soft dry cloth. If it is heavily contaminated, should be wiped by moisten cloth with isopropyl alcohol or ethyl alcohol solvents, DO NOT with water, ketone type materials (e.g. acetone), aromatic, toluene, ethyl acid or methyl chloride, and so on.
- (6) If the liquid crystal material leaks from the panel, it should be kept away from the eyes or mouth. In case of contact with hands, legs or clothes, it must be washed away thoroughly with soap.
- (7) Use finger-stalls with sort gloves in order to keep display clean during the incoming inspection and assembly process.
- (8) Protection film for polarizer on the module shall be slowly peeled off just before use so that the electrostatic charge can be minimized.
- (9) Do not touch directly conductive parts such as the CMOS LSI pad and the interface terminals with bare hands, therefore operations should be grounded whenever he/she comes into contact with the modules.
- (10) Do not exceed the absolute maximum rating value. (The supply voltage variation, input voltage variation, variation in part contents and environmental temperature, and so on), otherwise the module may be damaged.

### 1.2 SOLDERING

- (11) Use soldering irons with proper grounding and no leakage.
- (12) For No RoHS Product: soldering temperature is 290~350°C, soldering time is 3~5s; for RoHS Product: soldering temperature is 340~370°C, soldering time is 3~5s.
- (13) If soldering flux is used, be sure to remove any remaining flux after soldering (This does not apply in the case of a non-halogen type of flux).

### 1.3 STORAGE

- (1) DO NOT leave the module in high temperature and high humidity for a long times, keep the temperature from 0°C to 35°C and relative humidity of less than 60%.

- (2) It is highly recommended to store the module in a dark place. The Liquid crystal is deteriorated by ultraviolet, DO NOT leave it in direct sunlight and strong ultraviolet ray for many hours.
- (3) The polarizer surface should not come in contact with any other objects.