



Chefree Technology Corp.

TFT COLOR LCD MODULE

MODEL: CH101ELHLWN-001

(Complied with RoHS)

WXGA
LVDS interface

Version: P00

Customer : _____
Approved By : _____
Date: _____

CHEFREE		
APPROVAL	CHECKER	PREPARE
Tim	Mark	Benson

CONTENTS

1. RECORD OF REVISION	1
2. MECHANICAL SPECIFICATIONS	2
3. OUTLINE DIMENSIONS	3
4. INTERFACE PIN CONNECTION	4
5. BLOCK DIAGRAM	6
6. ABSOLUTE MAXIMUM RATINGS	7
7. ELECTRICAL CHARACTERISTICS	8
8. OPTICAL CHARACTERISTICS	10
9. TOUCH PANEL SPECIFICATIONS	13
10. TIMING SPECIFICATIONS	14
11. RELIABILITY TEST	17
12. PRECAUTIONS FOR USE	18

2. MECHANICAL SPECIFICATIONS

(1)	Number of Dots	1280(R.G.B) x 800
(2)	Module Size(mm)	229.46(H) x 149.1(V) x 6.9 (D)
(3)	Active Area(mm)	216.96(H) x 135.60(V)
(4)	Pixel Pitch(mm)	0.1695(H) x 0.1695(V)
(5)	LCD Model	TFT, Transmissive, Normally Black
(6)	Backlight Color	White
(7)	Viewing Direction	Wide View Angle
(8)	Electrical Interface	LVDS Interface
(9)	Color Configuration	R.G.B Vertical Stripe
(10)	Touch Panel Mode	Without Touch
(11)	Module Weight(g)	265±5%

3. OUTLINE DIMENSIONS

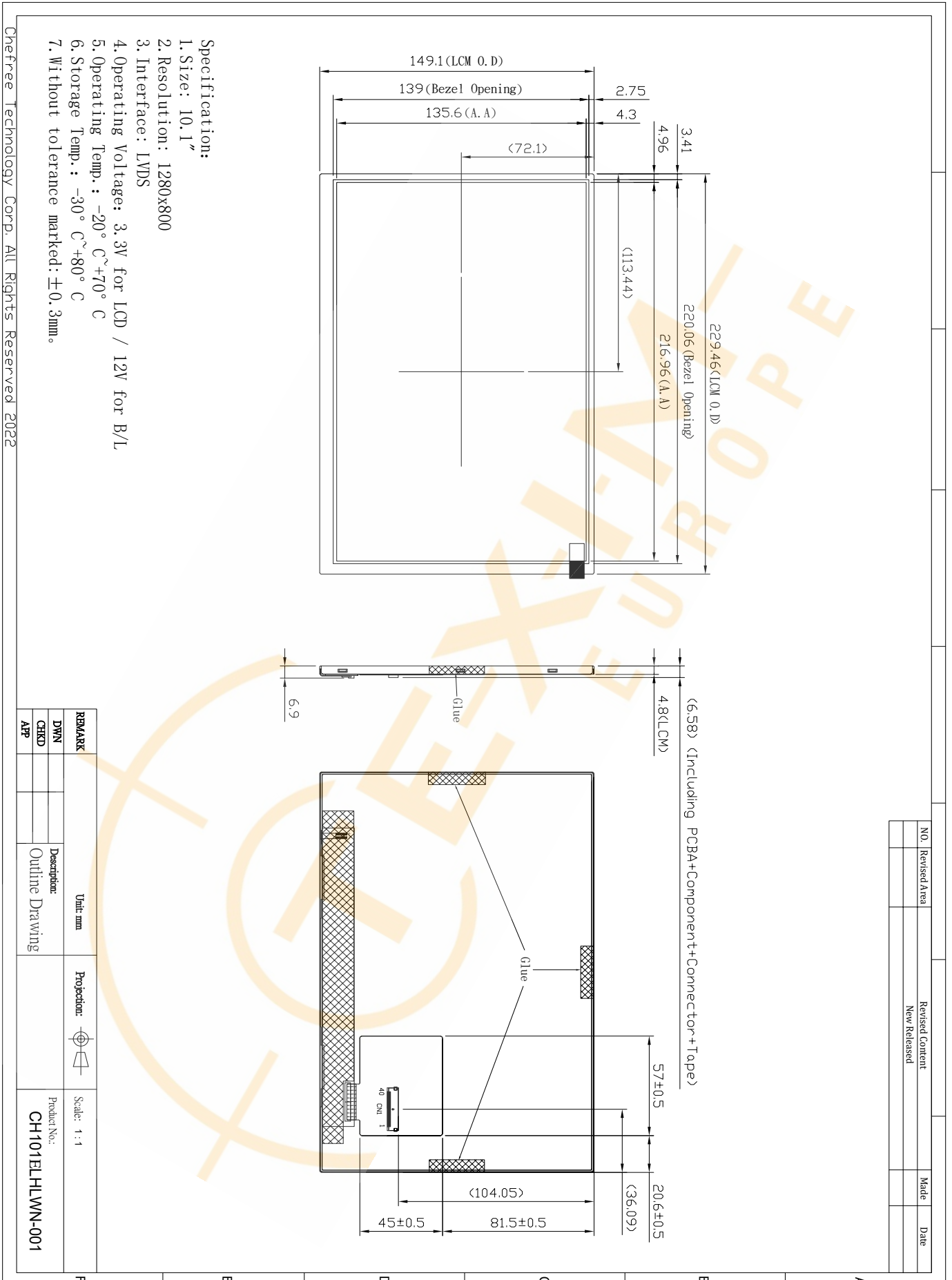

4. INTERFACE PIN CONNECTION

4.1 TFT LCM PANEL PIN DEFINE

CN1 Connector : HIROSE, TF07V-40S-0.5SH or Equivalent

PIN NO.	Definition	I/O	Description	Remark
1	NC	-	No connection	
2	VDD	P	Power Supply for Digital Circuit	
3	VDD	P	Power Supply for Digital Circuit	
4	NC	-	No connection	
5	NC	-	No connection	
6	NC	-	No connection	
7	GND	P	Ground	
8	RxIN0-	I	Negative LVDS Differential Data Input	
9	RxIN0+	I	Positive LVDS Differential Data Input	
10	GND	P	Ground	
11	RxIN1-	I	Negative LVDS Differential Data Input	
12	RxIN1+	I	Positive LVDS Differential Data Input	
13	GND	P	Ground	
14	RxIN2-	I	Negative LVDS Differential Data Input	
15	RxIN2+	I	Positive LVDS Differential Data Input	
16	GND	P	Ground	
17	CLKIN-	I	Negative LVDS Differential Clock Input	
18	CLKIN+	I	Positive LVDS Differential Clock Input	
19	GND	P	Ground	
20	RxIN3-	I	Negative LVDS Differential Data Input	
21	RxIN3+	I	Positive LVDS Differential Data Input	
22	GND	P	Ground	
23	LED_GND	P	Ground for backlight	
24	LED_GND	P	Ground for backlight	
25	LED_GND	P	Ground for backlight	
26	NC	-	No connection	
27	LED_PWM	I	Brightness Control For Backlight	
28	LED_EN	I	Enable Control For Backlight	
29	NC	-	No connection	
30	NC	-	No connection	
31	VLED	P	Power supply for backlight	
32	VLED	P	Power supply for backlight	
33	VLED	P	Power supply for backlight	
34	NC	-	No connection	
35	NC	-	No connection	
36	NC	-	No connection	

37	GND	P	Ground	
38	NC	-	No connection	
39	NC	-	No connection	
40	NC	-	No connection	

Note : 'P' stand for Power, 'I' stand for Input



5. BLOCK DIAGRAM

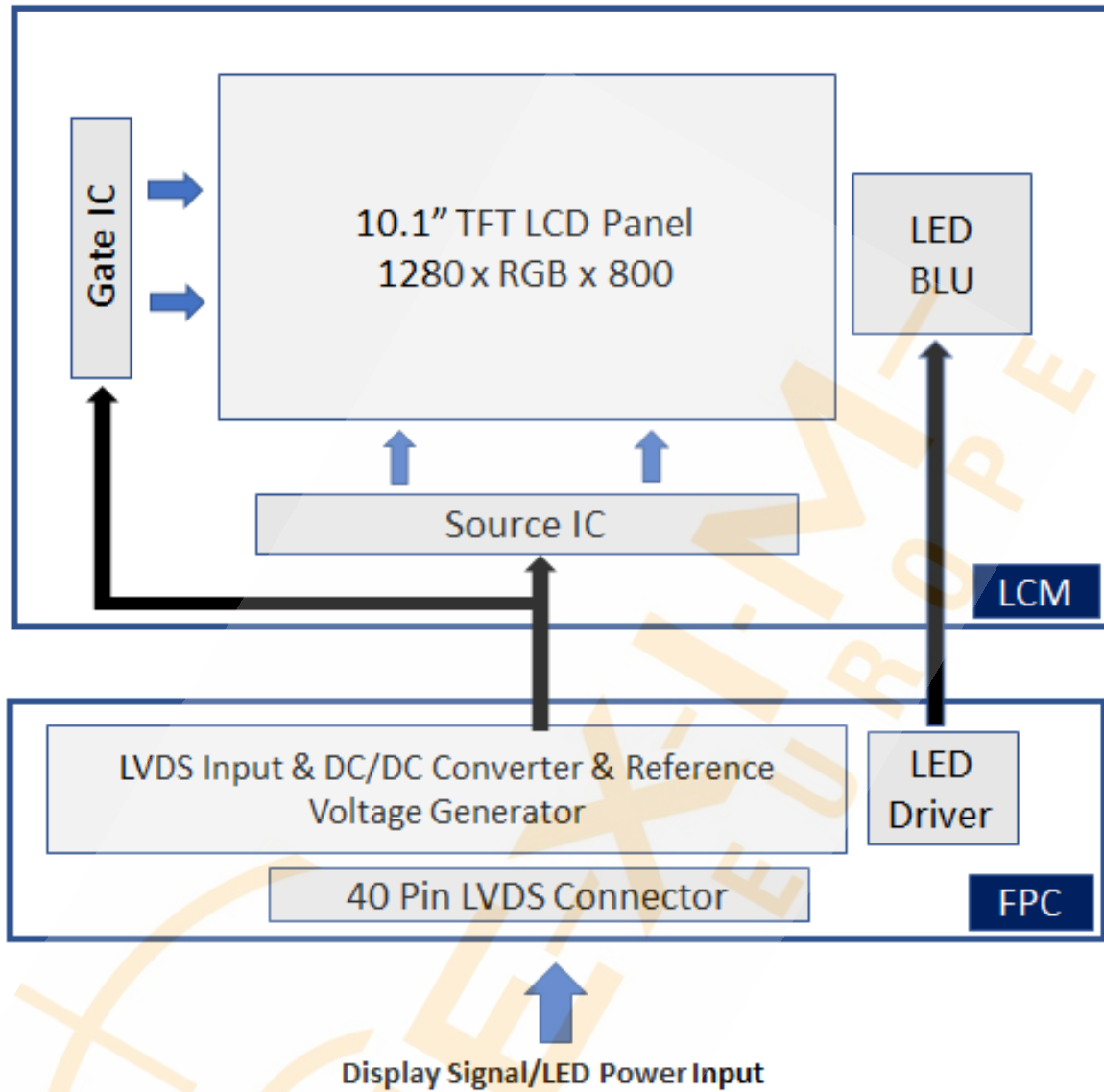

6. ABSOLUTE MAXIMUM RATINGS

6.1 ELECTRICAL ABSOLUTE MAXIMUM RATINGS

ITEM	SYMBOL	MIN.	MAX.	UNIT	REMARK
Power Supply Voltage	VDD	-0.3	3.9	V	

Note : The absolute maximum rating values of this product not allowed to be Exceeded at any times. Should be module be used with any of absolute maximum ratings exceeded. The characteristics of the module may not be recovered, or in an extreme case, the module may be permanently destroyed.

6.2 ENVIRONMENTAL ABSOLUTE MAXIMUM RATINGS

ITEM	OPERATING		STORAGE		REMARK
	MIN.	MAX.	MIN.	MAX.	
Ambient Temperature(°C)	-20	70	-30	80	Note 1,2
Humidity(% RH)	10~90(Note3)		10~90(Note 3)		-

Note 1 : The response time will become lower when operated at low temperature.

Note 2 : Background color changes slightly depending on ambient temperature.

7. ELECTRICAL CHARACTERISTICS

7.1 ELECTRICAL CHARACTERISTICS OF LCD

Ta=25°C

ITEM	SYMBOL	MIN.	TYP.	MAX.	UNIT	REMARK
Power Voltage For LCD	VDD	3.0	3.3	3.6	V	
	IDD	-	200	250	mA	Note1
Differential Input Threshold	VTH	-	-	+100	mV	Note2
	VTL	-100	-	-	mV	
Magnitude Differential Input	V _{ID}	100		600	mV	
Common Mode Voltage	V _{CM}	0.7	-	1.6	V	

Note 1 : Test Condition: VDD=3.3V ; Test Pattern: White.

Note 2 : VTH and VTL is defined in RxIN0+/- 、 RxIN1+/- 、 RxIN2+/- 、 RxIN3+/- 、 CLKIN+/- signal voltage level.

Single-end signals

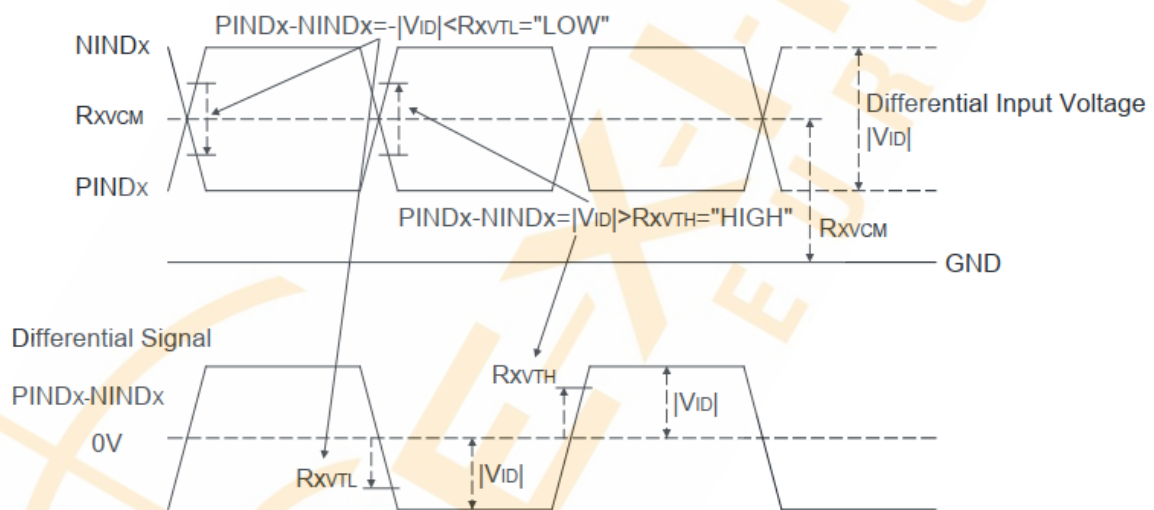

7.2 BACKLIGHT UNITS

Ta=25°C

ITEM	SYMBOL	MIN.	TYP.	MAX.	UNIT	REMARK
Forward Voltage	VLED	11.5	12	12.5	V	
Forward Current	ILED	-	300	350	mA	VLED=12V
Brightness Control	High	1.4	-	-	V	
	Low	0	-	0.7	V	
PWM Frequency	-	100		1000	Hz	
LED Life Time	Lf	30,000	50,000	-	Hrs	

Note 1 : The LED of B/L is drive by current only, drive voltage is for reference only.

Drive voltage can make driving current under safety area 30,000 hours is only an estimate for reference.

Note 2 : The lifetime of LED is defined as the time when it continues to operate under the conditions at Ta= 25 ±2°C and PWM = 100% (LED forward current) until the brightness becomes ≤ 50% of its original value.

8. OPTICAL CHARACTERISTICS

8.1 Optical specification

Ta=25°C

ITEM		SYMBOL	CONDITIONS	MIN.	TYP.	MAX.	UNIT	REMARK
Contrast Ratio		CR	Viewing Normal Angle $\Theta_x=\Theta_y=0^\circ$	600	800	-	-	Note 1
Response Time		Tr+Tf		-	25	50	ms	Note 2
Color Chromaticity	White	Wx		0.26	0.31	0.36		Note 4
		Wy	0.27	0.32	0.37			
Viewing Angle	Hor.	θ_L	Viewing Angle $\Theta_x=\Theta_y=0^\circ$ $CR \geq 10$	75	85	-	Deg.	Note 4
		θ_R		75	85	-		
	Ver.	θ_U		75	85	-		
		θ_D		75	85	-		
Luminance(Center)		L	450	600	-	cd/m ²	Center	
Luminance Uniformity		YU	PWM=100%	70	75	-	%	Note 5

Note 1 : Definition of Contrast Ratio (CR) :

The contrast ratio can be calculated by the following expression.

$$\text{Contrast Ratio (CR)} = L_{63}/L_0$$

L63 : Luminance of gray level 63

L0 : Luminance of gray level 0

$$CR = CR(5)$$

CR(X) is corresponding to the Contrast Ratio of the point X at Figure in Note 5

Note 2 : Definition of Response Time (TR.TF)

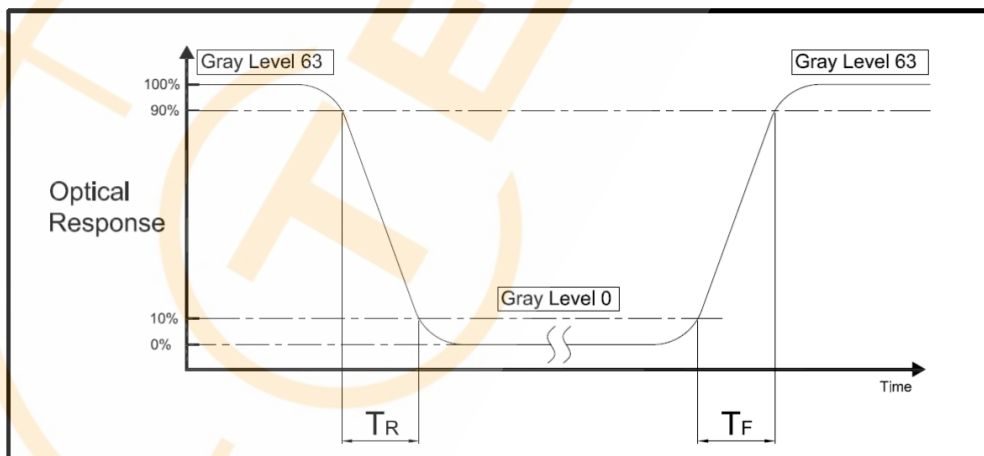

Note 3 : Definition of Viewing Angle

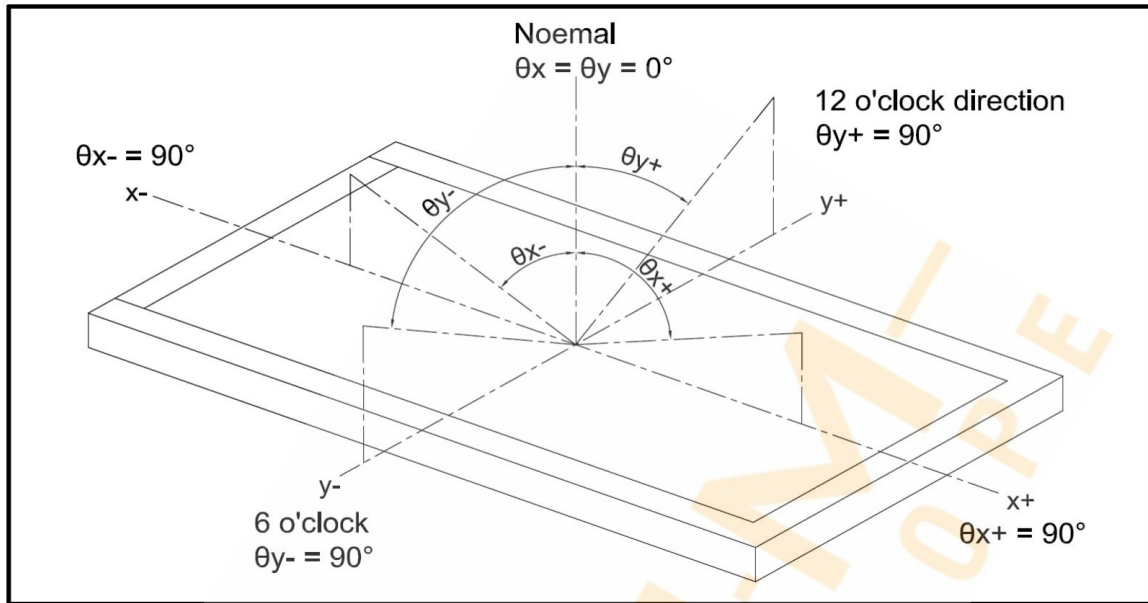

Note 4 : Measurement Set-Up:

The LCD module should be stabilized at a given temperature for 20 minutes to avoid abrupt temperature change during measuring. In order stabilize the luminance, the measurement should be executed after lighting Backlight for 20 minutes in a windless room.

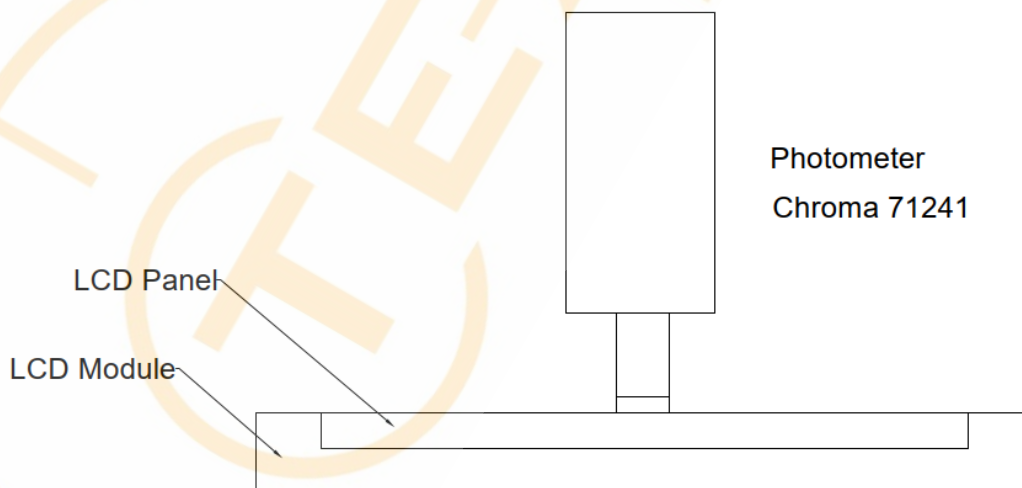

Note 5: Definition of uniformity (Un)

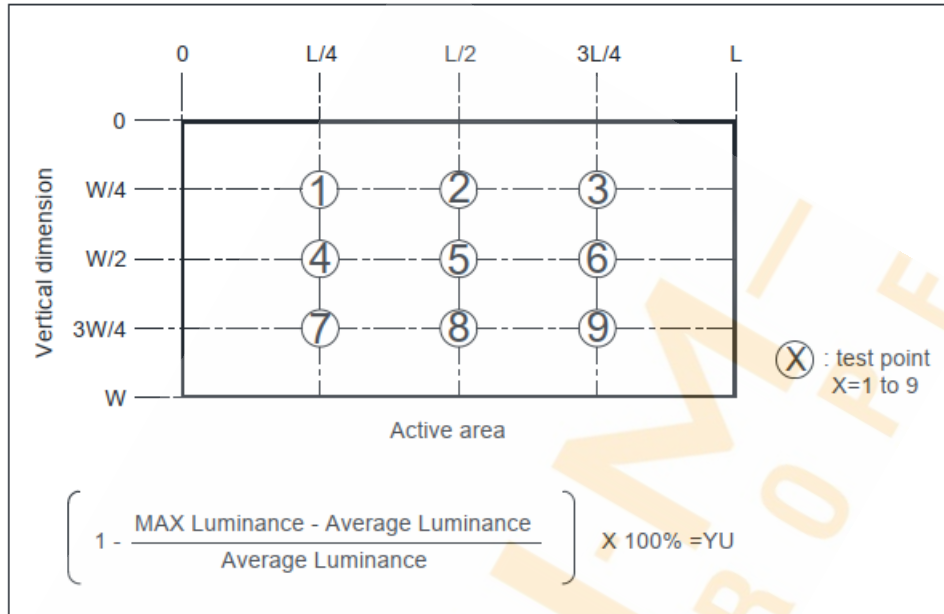

9. TOUCH PANEL SPECIFICATIONS

9.1 Type :

9.2 STRUCTURE :

9.2.1 Thickness :

9.3 IC MODEL :

9.3.1 IC manufacture :

9.3.2 IC part number :

9.3.3 Interface :

9.4 ELECTRICAL CHARACTERISTICS :

9.4.1 Operating Voltage :

9.5 MECHANICAL CHARACTERISTICS :

9.5.1 Surface hardness :

9.6 OPTICAL CHARACTERISTICS :

9.6.1 Transparency :

9.6.2 Haze:

10. TIMING SPECIFICATIONS

10.1 Power on/off Sequence

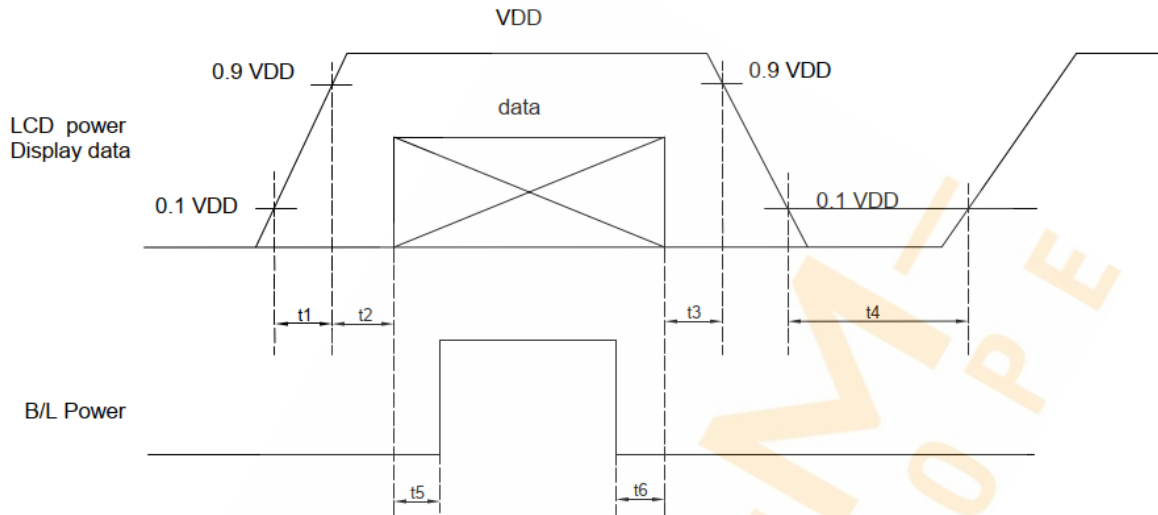

ITEM	MIN.	MAX.	NOTE
t1	0.5	10	
t2	0	50	
t3	0	50	
t4	200	-	
t5	120	-	
t6	0	-	

UNIT: ms

10.2 Timing Table

ITEM	SYMBOL	MIN.	TYP.	MAX.	UNIT	NOTE
DCLK frequency	1/Tc	66.3	72.4	78.9	MHz	Frame rate=60Hz
Horizontal Display area	tHD	1280			Tc	
HSYNC pulse width	tHPW	2	-	40	Tc	
HSYNC back porch(with pulse width)	tHBP	88	88	88	Tc	
HSYNC front porch	tHFP	12	72	132	Tc	
Vertical display area	tVD	800			tH	
VSYNC pulse width	tVPW	2	-	20	tH	
VSYNC back porch(with pulse width)	tVBP	23	23	23	tH	
VSYNC front porch	tVFP	1	15	49	tH	

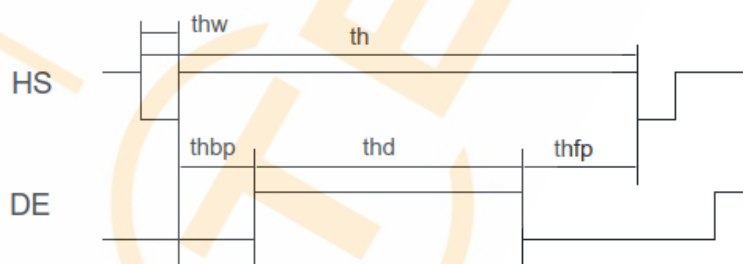
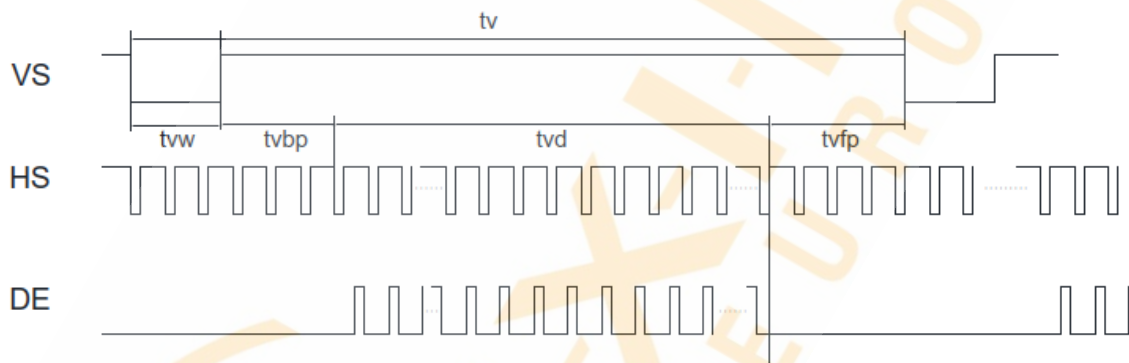

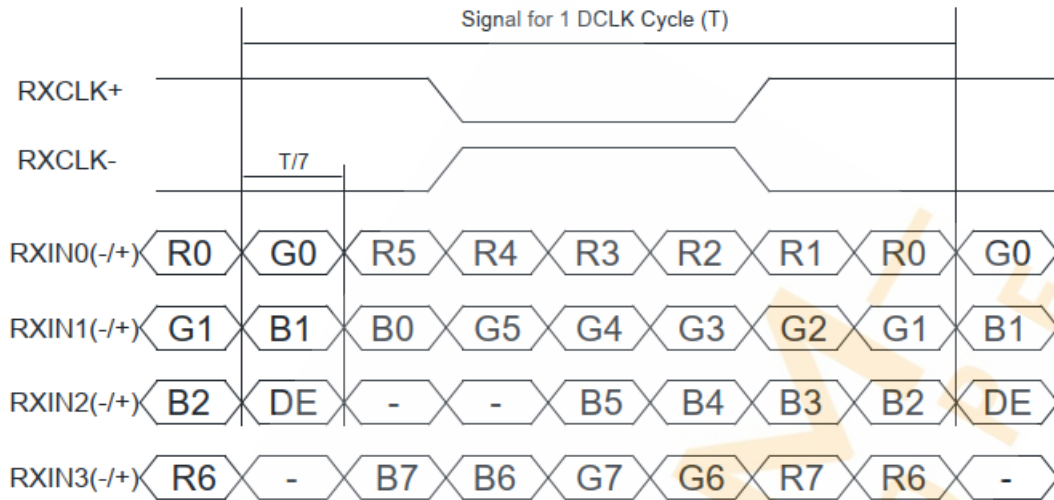
10.3 Data Input Format

11. RELIABILITY TEST

ENVIRONMENTAL TEST				
NO.	ITEM	CONDITIONS	TIME PERIOD	REMARK
1	High Temperature Storage	Ta= 80°C	240Hours	1,2,3,4
2	Low Temperature Storage	Ta= -30°C	240Hours	1,2,3,4
3	High Temperature Humidity Storage	40°C,90%RH	240Hours	1,2,3,4
4	High Temperature Operation	Ts= 70°C	240Hours	1,2,3,4
5	Low Temperature Operation	Ta= -20°C	240Hours	1,2,3,4,5
6	Temperature Cycle	-20°C~70°C (30min) (30min)	100 CYCLES	1,2,3

Note 1 : There is no display function NG issue occurred, all the cosmetic specification is judged before the reliability stress.

Note 2 : All of the function & cosmetic judgment basis base on IIS Spec. at room temperature.
(The tested module must have enough recovery time at least 2 hours at room temperature.)

Note 3 : The test condition definition panel's surface temperature.

Note 4 : After 1000 hours test has been done, the specimen should function normally without any fatal defect. (no picture, line defect, out of synchronization)

Note 5 : Short time operation between -40~30°C doesn't provide full performance but a correct image on the LCD. The LCD is guaranteed to suffer no permanent damage.

12. PRECAUTIONS FOR USE

14.1 SAFETY

- (1) Do not swallow any liquid crystal, even if there is no proof that liquid crystal is poisonous.
- (2) If the LCD panel breaks, be careful not to get liquid crystal to touch your skin.
- (3) If skin is exposed to liquid crystal, wash the area thoroughly with alcohol or soap.

14.2 STORAGE CONDITIONS

- (1) Store the panel or module in a dark place where the temperature is $23\pm 5^{\circ}\text{C}$ and the humidity is below $50\pm 20\%\text{RH}$.
- (2) Store in anti-static electricity container.
- (3) Store in clean environment, free from dust, active gas, and solvent.
- (4) Do not place the module near organics solvents or corrosive gases.
- (5) Do not crush, shake, or jolt the module.

14.3 HANDLING PRECAUTIONS

- (1) Avoid static electricity which can damage the CMOS LSI.
- (2) The polarizing plate of the display is very fragile. So, please handle it very carefully.
- (3) Do not give external shock.
- (4) Do not apply excessive force on the surface.
- (5) Do not wipe the polarizing plate with a dry cloth, as it may easily scratch the Surface of plate.
- (6) Do not use ketonic solvent & Aromatic solvent, use with a soft cloth soaked with a cleaning naphtha solvent.
- (7) Do not operate it above the absolute maximum rating.
- (8) Do not remove the panel or frame from the module.
- (9) When the module is assembled, it should be attached to the system firmly, Be careful not to twist and bend the module.
- (10) Wipe off water droplets or oil immediately . If you leave the droplets for a long time, staining and discoloration may occur.
- (11) If the liquid crystal material leaks from the panel, it should be kept away from the eyes or mouth.
In case of contact with hands, legs or clothes, it must be washed away thoroughly with soap.

14.4 WARRANTY

- (1) Acceptance inspection period. The period is within one month after the arrival of contracted commodity at the buyer's factory site.
- (2) Applicable warrant period. The period is within 12 months since the date of shipping out under normal using and storage conditions.