

# Chefree Technology Corp.

## TFT COLOR LCD MODULE

MODEL: CF101VLHLWH-002

(Complied with RoHS)

WXGA  
LVDS interface (1 Port)

Version: P04

Customer : _____
Approved By : _____
Date: _____

CHEFREE		
APPROVAL	CHECKER	PREPARE
Tim	Mark	Jacky

## **C O N T E N T S**

1. RECORD OF REVISION.....	1
2. MECHANICAL SPECIFICATIONS .....	2
3. OUTLINE DIMENSIONS .....	3
4. INTERFACE PIN CONNECTION .....	4
5. BLOCK DIAGRAM.....	6
6. ABSOLUTE MAXIMUM RATINGS .....	7
7. ELECTRICAL CHARACTERISTICS.....	8
8. OPTICAL CHARACTERISTICS.....	10
9. TOUCH PANEL SPECIFICATIONS .....	12
10. TIMING SPECIFICATIONS .....	13
11. RELIABILITY TEST .....	15
12. LCM INSPECTION STANDARD.....	15
13. PACKAGE INFORMATION.....	15
14. PRECAUTIONS FOR USE.....	16



## 1. RECORD OF REVISION

Rev	DATE	PAGE	SUMMARY
P01	2019.06.21	ALL	Preliminary specification was first issued.
P02	2019.07.02	3	Back View Drawing Revised
P03	2019.10.02	3	PCB location changed
P04	2021.08.16	3	Updated drawing( LCD AA center moves up 1.1mm)
		9	Modify the B/L of power consumption

## 2. MECHANICAL SPECIFICATIONS

(1)	Number Of Dots (Dots)	1280(R.G.B) x 800
(2)	Module Size(mm)	231(H) x 153.9(V) x 11 (D)
(3)	Active Area(mm)	216.96(H) x 135.6(V)
(4)	Pixel Pitch(mm)	0.1695(H) x 0.1695(V)
(5)	LCD Model	TFT, Transmissive, Normally Black
(6)	Backlight Color	White, LED
(7)	Viewing Direction	All
(8)	Electrical Interface	LVDS Interface
(9)	Color Configuration	R.G.B Stripe
(10)	Touch Panel Mode	Without Touch
(11)	Module Weight(g)	260 ± 5%



### 3. OUTLINE DIMENSIONS

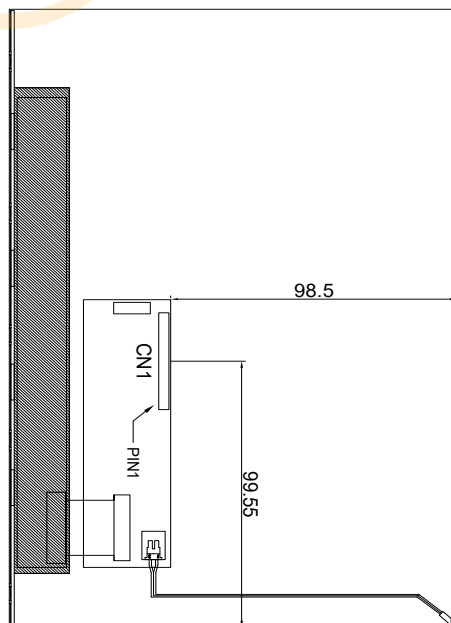
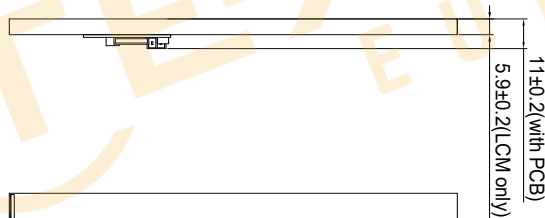
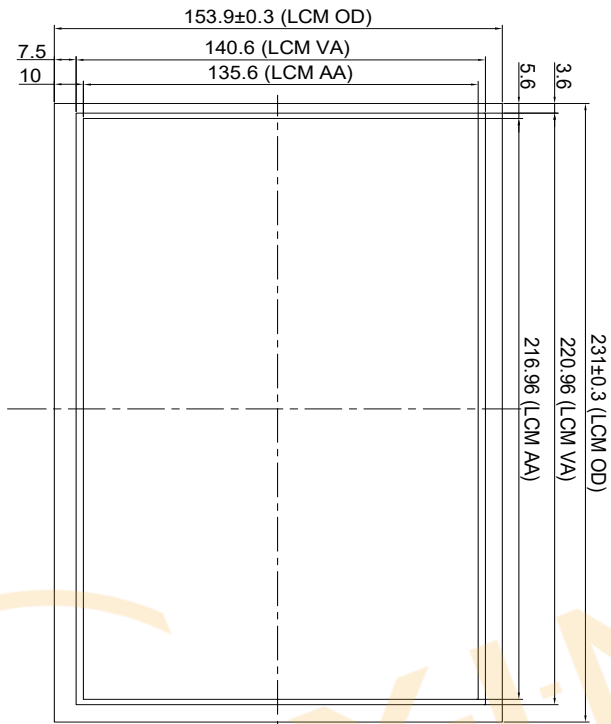

- Specification:
1. Size: 10.1"
  2. Resolution: 1280x800
  3. Interface: LVDS
  4. Operating Voltage: 3.3V for LCD / 12V for B/L
  5. Operating Temp.: -30° C ~ +80° C
  6. Storage Temp.: -30° C ~ +80° C
  7. Without tolerance marked: ±0.3mm.

Copyright © CHEFFREE Technology Corporation. All rights reserved

Remark	Unit:mm	投影法:	SCALE: NTS
Made	Jimmy	2020.03.04	名称:
Checked			Outline Dimension
Approved	Tim		

NO.	Modified	Content	Made	Date
		New Released		

## 4. INTERFACE PIN CONNECTION

### 4.1 TFT LCM PANEL PIN DEFINE

CN1 Connector : STM MSBK2407P30 RF:HB or Equivalent

PIN NO.	Definition	I/O	Description	Remark
1	GND	P	Ground	
2	GND	P	Ground	
3	EN	I	Enable Control for Backlight	
4	PWM	I	Brightness Control for Backlight	
5	VLED	P	Power Supply for LED Backlight (12V)	
6	VLED	P	Power Supply for LED Backlight (12V)	
7	VDD	P	Power Supply for Digital Circuit (3.3V)	
8	NC	-	No connection	
9	NC	-	No connection	
10	GND	P	Ground	
11	RxIN0-	I	Negative LVDS Differential Data Input	
12	RxIN0+	I	Positive LVDS Differential Data Input	
13	GND	P	Ground	
14	RxIN1-	I	Negative LVDS Differential Data Input	
15	RxIN1+	I	Positive LVDS Differential Data Input	
16	GND	P	Ground	
17	RxIN2-	I	Negative LVDS Differential Data Input	
18	RxIN2+	I	Positive LVDS Differential Data Input	
19	GND	P	Ground	
20	RxCLK-	I	Negative LVDS Differential Clock Input	
21	RxCLK+	I	Positive LVDS Differential Clock Input	
22	GND	P	Ground	
23	RxIN3-	I	Negative LVDS Differential Data Input	
24	RxIN3+	I	Positive LVDS Differential Data Input	
25	VDD	P	Power Supply for Digital Circuit (3.3V)	
26	NC	-	No connection	
27	NC	-	No connection	
28	NC	-	No connection	
29	NC	-	No connection	
30	GND	P	Ground	

Note : 'P' stand for Power, 'I' stand for Input

#### 4.2 CTP Specification:

**Without Touch.**



5. BLOCK DIAGRAM

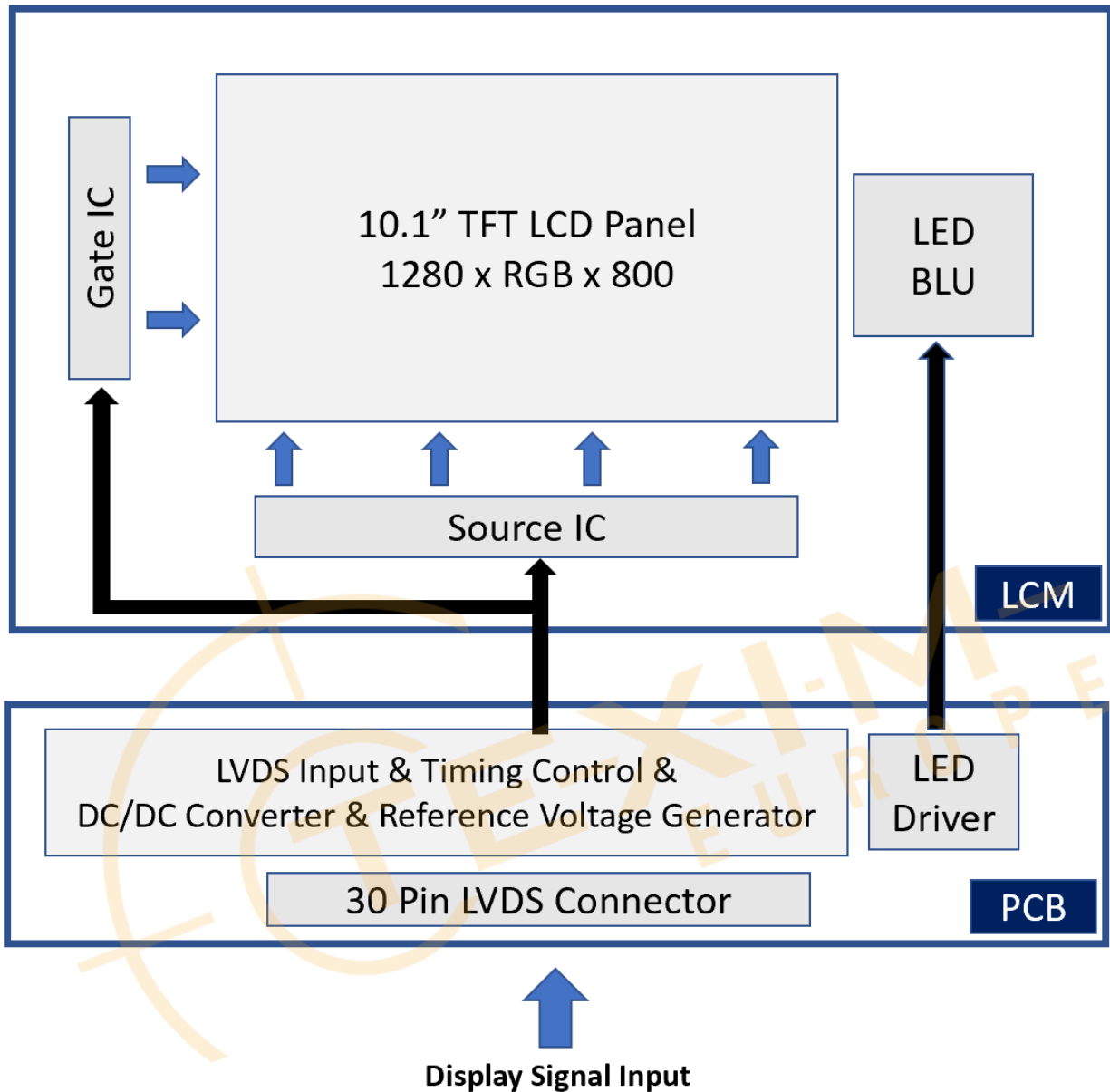



## 6. ABSOLUTE MAXIMUM RATINGS

### 6.1 ELECTRICAL ABSOLUTE MAXIMUM RATINGS

ITEM	SYMBOL	MIN.	MAX.	UNIT	REMARK
Power Supply Voltage	VDD	0.2	5.0	V	
Power Supply Voltage	VLED	11.7	13.8	V	
Power Voltage For CTP	/	/	/	V	

Note : The absolute maximum rating values of this product not allowed to be Exceeded at any times. Should be module be used with any of absolute maximum ratings exceeded. The characteristics of the module may not be recovered, or in an extreme case, the module may be permanently destroyed.

### 6.2 ENVIRONMENTAL ABSOLUTE MAXIMUM RATINGS

ITEM	OPERATING		STORAGE		REMARK
	MIN.	MAX.	MIN.	MAX.	
Ambient Temperature(°C)	-30	80	-30	80	Note 1,2
Humidity(% RH)	10~90(Note3)		10~90(Note 3)		-

Note 1 : The response time will become lower when operated at low temperature.

Note 2 : Background color changes slightly depending on ambient temperature.

Note 3 : Storage Ta=40°C & RH=90% ≤ 96Hrs

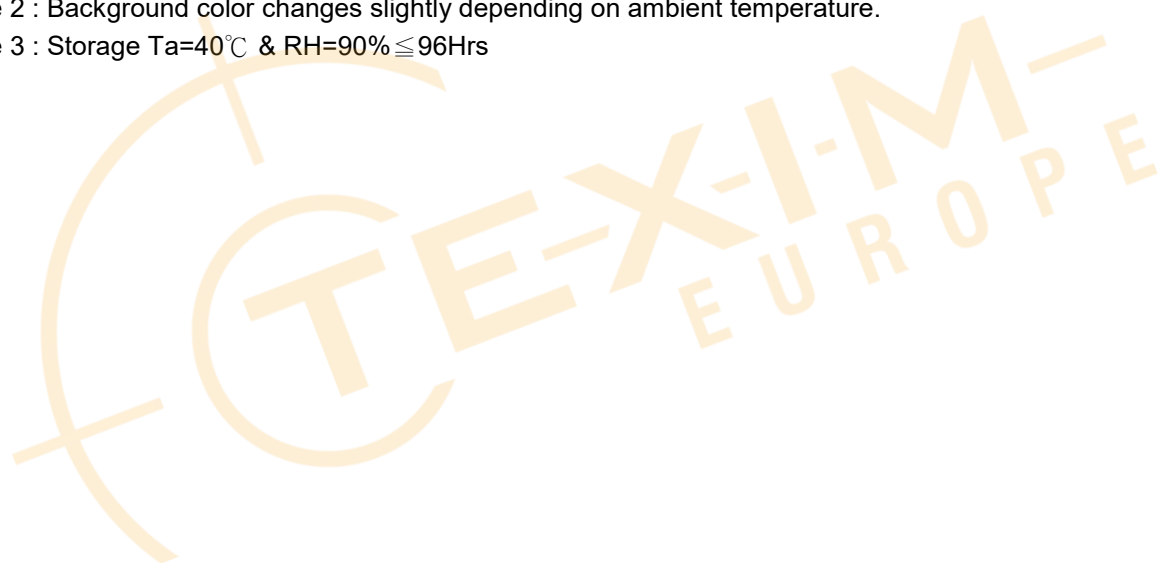

## 7. ELECTRICAL CHARACTERISTICS

### 7.1 ELECTRICAL CHARACTERISTICS OF LCD

Ta=25°C

ITEM	SYMBOL	MIN.	TYP.	MAX.	UNIT	REMARK
Power Voltage For LCD	VDD	3.0	3.3	3.6	V	
	IDD	-	270	-	mA	Note1
Differential Input Threshold	VTH	-	-	+100	mV	Note2
	VTL	-100	-	-	mV	
Magnitude Differential Input	V <sub>ID</sub>	100		600	mV	
Common Mode Voltage	V <sub>CM</sub>	1	1.2	1.4	V	

Note 1 : Test Condition: VDD=3.3V ; Test Pattern: Black.

Note 2 : VTH and VTL is defined in RxIN0+/- 、 RxIN1+/- 、 RxIN2+/- 、 RxIN3+/- 、 RxCLK+/- signal voltage level.

#### Voltage Definitions

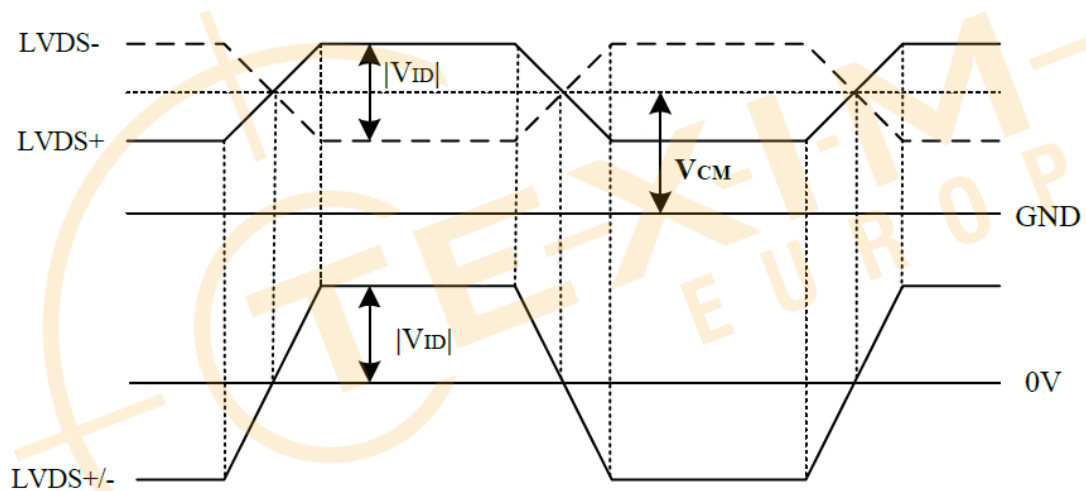

**7.2 BACKLIGHT UNITS**

Ta=25°C

ITEM		SYMBOL	MIN.	TYP.	MAX.	UNIT	REMARK
LED Driving Voltage		VLED	11.7	12	13.8	V	
LED Driving Current		ILED	-	0.75	-	A	
LED Life Time		-	-	30,000	-	Hrs	Note1
Brightness Control	Analog Dimming	ADJ					Note4
	PWM Dimming		1.4	-	5.0	V <sub>P-P</sub>	Note5
ADJ Frequency		-	220	1K	10K	Hz	

Note 1: The LED life time define as the estimated time to 50% degradation of initial luminous.

Note 2: Operating temperature 25°C, humidity 55%RH.

Note 3: A higher LED power supply voltage will result in better power efficiency.

Keep the VLED between 12V and 12.3V is strongly recommended.

Note 4: ADJ signal VP-P=1.4~5.0V, operation frequency: 220Hz~10KHz .

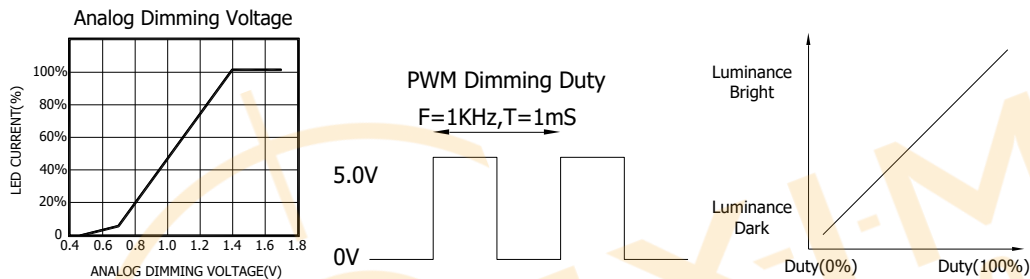
**7.3 CTP ELECTRICAL CHARACTERISTICS**

ITEM	SYMBOL	MIN.	TYP.	MAX.	UNIT	REMARK
Power Voltage For PCAP	VCC	/	/	/	V	

## 8. OPTICAL CHARACTERISTICS

Ta=25°C

ITEM	SYMBOL	CONDITIONS	MIN.	TYP.	MAX.	UNIT	REMARK
Contrast Ratio	CR	Viewing Normal Angle $\Theta_x = \Theta_y = 0^\circ$	600	800	-	-	Note 1
Response Time	TR+TF		-	25	50	ms	Note 2
Chromaticity	White	x	0.26	0.31	0.36	-	Note 4
		y	0.27	0.32	0.37	-	
Viewing Angle	Hor.	$\theta_{x+}$	-	85	-	Deg.	Note 3
		$\theta_{x-}$	-	85	-		
	Ver.	$\theta_{y+}$	-	85	-		
		$\theta_{y-}$	-	85	-		
Luminance	L	PWM=100%	800	1000	-	cd/m <sup>2</sup>	Center
Luminance Uniformity	YU		70	75	-	%	Note 5

Note 1 : Definition of Contrast Ratio (CR) :

The contrast ratio can be calculated by the following expression.

$$\text{Contrast Ratio (CR)} = L_{63}/L_0$$

L63 : Luminance of gray level 63

L0 : Luminance of gray level 0

$$\text{CR} = \text{CR}(5)$$

CR(X) is corresponding to the Contrast Ratio of the point X at Figure in Note 5

Note 2 : Definition of Response Time (TR.TF)

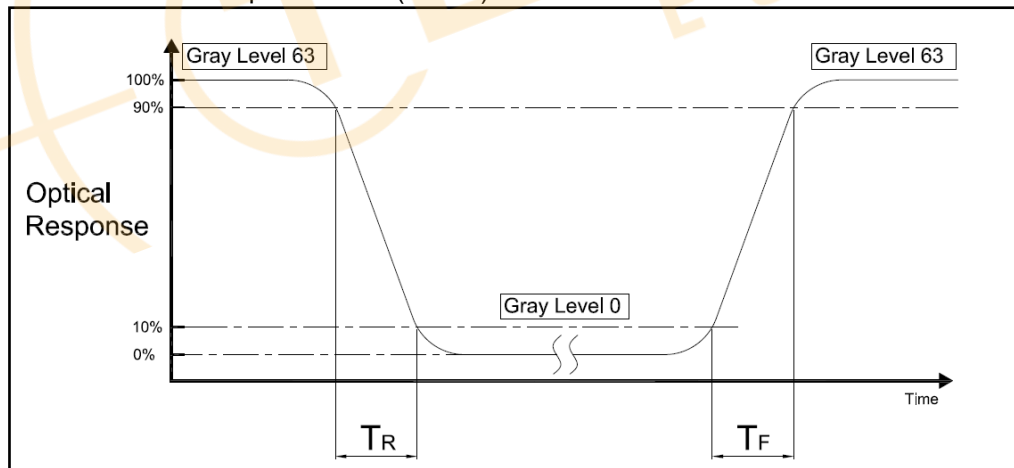

Note 3 : Definition of Viewing Angle

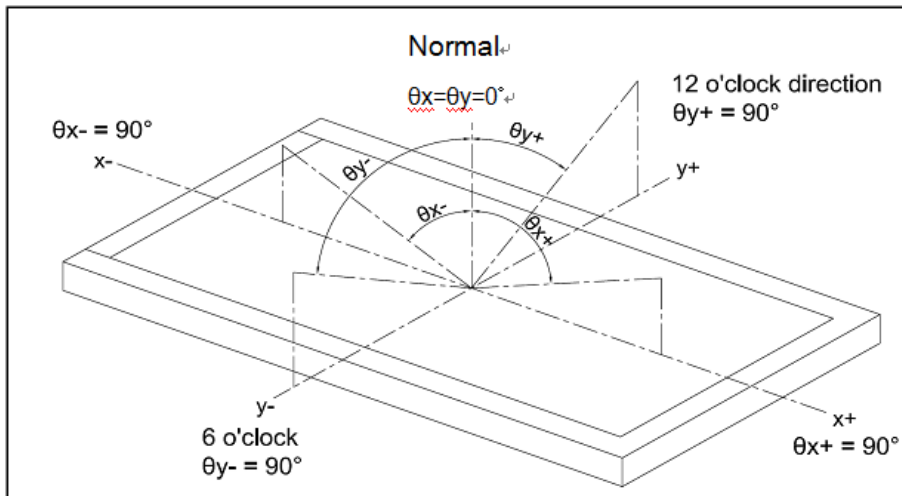

Note 4 : Measurement Set-Up :

The LCD module should be stabilized at a given temperature for 20 minutes to avoid abrupt temperature change during measuring. In order stabilize the luminance, the measurement should be executed after lighting Backlight for 20 minutes in a windless room.

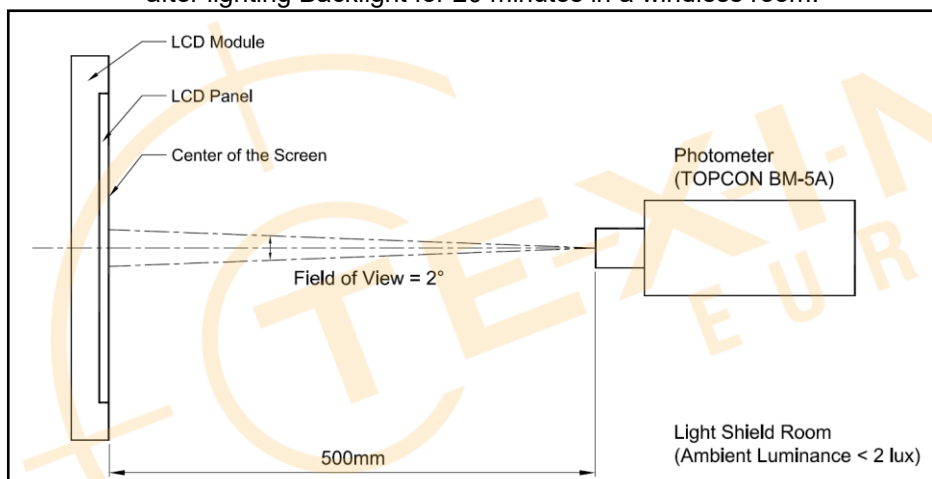

Note 5 :

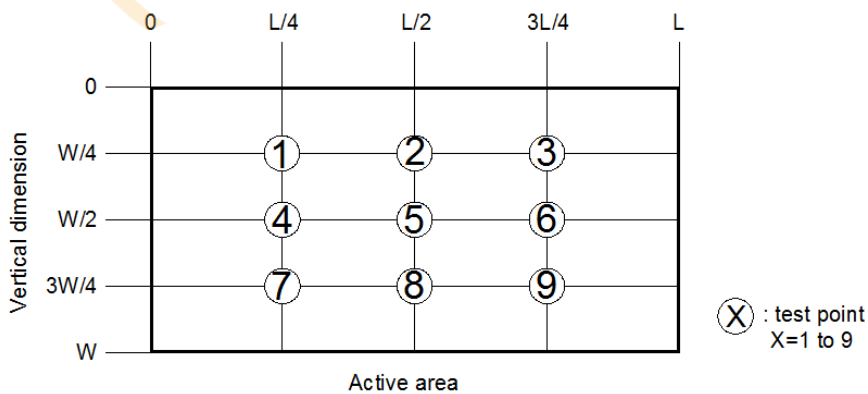

$$\left[ 1 - \frac{\text{MAX Luminance} - \text{Average Luminance}}{\text{Average Luminance}} \right] \times 100\% = \text{YU}$$

## 9. TOUCH PANEL SPECIFICATIONS

### 9.1 Type :

### 9.2 STRUCTURE :

9.2.1 Thickness :

### 9.3 IC MODEL :

9.3.1 IC manufacture :

9.3.2 IC part number :

9.3.3 Interface :

### 9.4 ELECTRICAL CHARACTERISTICS :

9.4.1 Operating Voltage :

### 9.5 MECHANICAL CHARACTERISTICS :

9.5.1 Surface hardness :

### 9.6 OPTICAL CHARACTERISTICS :

9.6.1 Transparency :

9.6.2 Haze:



## 10. TIMING SPECIFICATIONS

### 10.1 LCM POWER ON/OFF SUPPLY VOLTAGE SEQUENCE

Power on/off sequence is as follows. Interface signals are also shown in the chart. Signals from any system shall be Hi-Z state or low level when VDD is off.

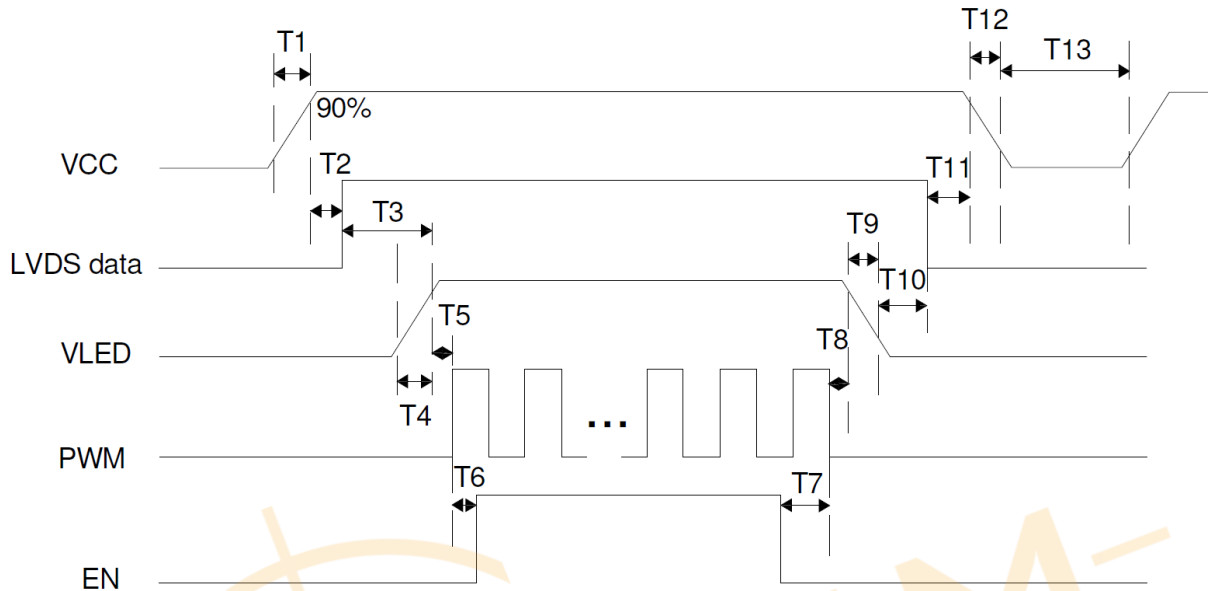

PARAMETER	SYMBOL	MIN	TYP.	MAX	UNIT
VIN Rise Time	T1	0.5	--	10	ms
VIN Good to Signal Valid	T2	30	--	90	ms
Signal Valid to Backlight On	T3	200	--	--	ms
Backlight Power On Time	T4	0.5	--	--	ms
Backlight VDD Good to System PWM	T5	10	--	--	ms
System PWM ON to Backlight Enable ON	T6	10	--	--	ms
Backlight Enable Off to System PWM Off	T7	0	--	--	ms
System PWM Off to B/L Power Disable	T8	10	--	--	ms
Backlight Power Off Time	T9	0.5	10	30	ms
Backlight Off to Signal Disable	T10	200	--	--	ms
Signal Disable to Power Down	T11	0	--	50	ms
VIN fall Time	T12	0.5	10	30	ms
Power Off	T13	500	--	--	ms

## 10.2 LCM Timing Characteristics

PARAMETER	SYMBOL	MIN.	TYP.	MAX.	UNIT	REMARK
LVDS Clock Frequency	Fclk	(70.0)	(72.4)	(76.6)	MHz	
H Total Time	HT	(1410)	(1440)	(1470)	Clocks	
H Active Time	HA	1280			Clocks	
V Total Time	VT	(828)	(838)	(868)	Lines	
V Active Time	VA	800			Lines	
Frame Rate	FV	-	60	-	Hz	

### LVDS Data Mapping

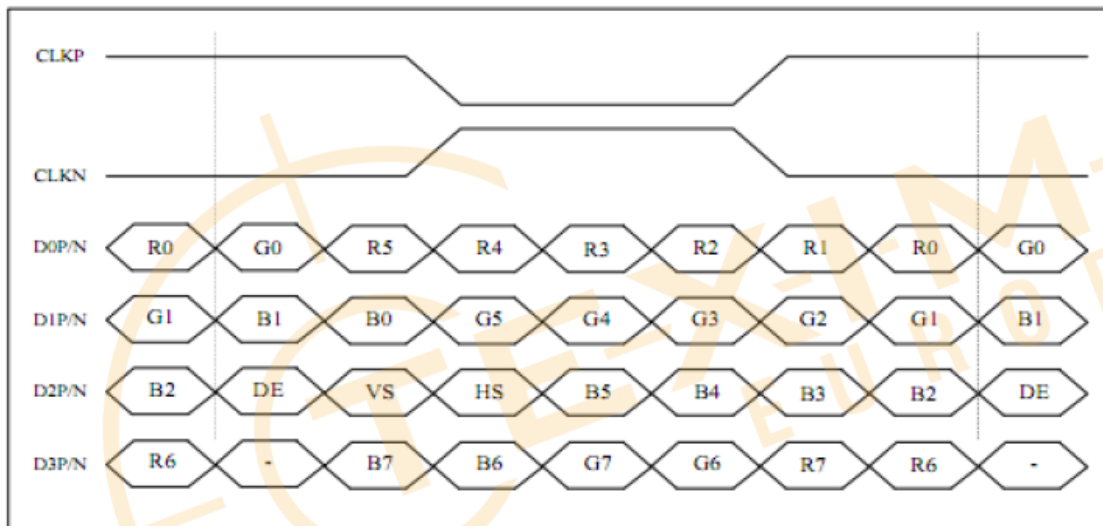



## 11. RELIABILITY TEST

ENVIRONMENTAL TEST				
NO.	ITEM	CONDITIONS	TIME PERIOD	REMARK
1	High Temperature Storage	Ta= 80°C	240Hours	Note 1,3
2	Low Temperature Storage	Ta= -30°C	240Hours	Note 1,3
3	High Temperature Humidity Storage	40°C,90%RH	240Hours	Note 1,3
4	High Temperature Operation	Ts= 80°C	240Hours	Note 2,3
5	Low Temperature Operation	Ta= -30°C	240Hours	Note 1,3
6	Temperature Cycle	-30°C~80°C	1H/cycle 50CYCLE	Note 2,4

In the standard condition, there shall be no practical problem that may affect the display function. After the reliability test, the product only guarantees operation, but don't guarantee all of the cosmetic specification.

Note 1 : Ta is the ambient temperature of samples.

Note 2 : Ts is the temperature of panel's surface.

Note 3 : Before cosmetic and function test, the product must have enough recovery time, at least 2 hours at room temperature.

Note 4 : Star with cold temperature and end with high temperature.

## 12. LCM INSPECTION STANDARD

Inspection specifications refer Document Number : QT3-QC-A-I004

## 13. PACKAGE INFORMATION

LCM Model	LCM Qty. in the box	Outer box Size (mm)	Weight(Kg)
CF101VLHLWH-001	TBD	TBD	TBD

## 14. PRECAUTIONS FOR USE

### 14.1 SAFETY

- (1) Do not swallow any liquid crystal, even if there is no proof that liquid crystal is poisonous.
- (2) If the LCD panel breaks, be careful not to get liquid crystal to touch your skin.
- (3) If skin is exposed to liquid crystal, wash the area thoroughly with alcohol or soap.

### 14.2 STORAGE CONDITIONS

- (1) Store the panel or module in a dark place where the temperature is  $23\pm 5^{\circ}\text{C}$  and the humidity is below  $50\pm 20\% \text{RH}$ .
- (2) Store in anti-static electricity container.
- (3) Store in clean environment, free from dust, active gas, and solvent.
- (4) Do not place the module near organics solvents or corrosive gases.
- (5) Do not crush, shake, or jolt the module.

### 14.3 HANDLING PRECAUTIONS

- (1) Avoid static electricity which can damage the CMOS LSI.
- (2) The polarizing plate of the display is very fragile. So, please handle it very carefully.
- (3) Do not give external shock.
- (4) Do not apply excessive force on the surface.
- (5) Do not wipe the polarizing plate with a dry cloth, as it may easily scratch the Surface of plate.
- (6) Do not use ketonic solvent & Aromatic solvent, use with a soft cloth soaked with a cleaning naphtha solvent.
- (7) Do not operate it above the absolute maximum rating.
- (8) Do not remove the panel or frame from the module.
- (9) When the module is assembled, it should be attached to the system firmly, Be careful not to twist and bend the module.
- (10) Wipe off water droplets or oil immediately . If you leave the droplets for a long time, staining and discoloration may occur.
- (11) If the liquid crystal material leaks from the panel, it should be kept away from the eyes or mouth. In case of contact with hands, legs or clothes, it must be washed away thoroughly with soap.

### 14.4 WARRANTY

- (1) Acceptance inspection period. The period is within one month after the arrival of contracted commodity at the buyer's factory site.
- (2) Applicable warrant period. The period is within 12 months since the date of shipping out under normal using and storage conditions.

## The Netherlands



Elektrostraat 17  
NL-7483 PG Haaksbergen

T: +31 (0)53 573 33 33  
F: +31 (0)53 573 33 30  
E: [nl@texim-europe.com](mailto:nl@texim-europe.com)

## Belgium



Zuiderlaan 14 bus 10  
B-1731 Zellik

T: +32 (0)2 462 01 00  
F: +32 (0)2 462 01 25  
E: [belgium@texim-europe.com](mailto:belgium@texim-europe.com)

## UK & Ireland



St. Mary's House, Church Lane  
Carlton Le Moorland  
Lincoln LN5 9HS

T: +44 (0)1522 789 555  
F: +44 (0)845 299 22 26  
E: [uk@texim-europe.com](mailto:uk@texim-europe.com)

## Germany North



Bahnhofstrasse 92  
D-25451 Quickborn

T: +49 (0)4106 627 07-0  
F: +49 (0)4106 627 07-20  
E: [germany@texim-europe.com](mailto:germany@texim-europe.com)

## Germany South



Martin-Kollar-Strasse 9  
D-81829 München

T: +49 (0)89 436 086-0  
F: +49 (0)89 436 086-19  
E: [germany@texim-europe.com](mailto:germany@texim-europe.com)

## Austria



Warwitzstrasse 9  
A-5020 Salzburg

T: +43 (0)662 216 026  
F: +43 (0)662 216 026-66  
E: [austria@texim-europe.com](mailto:austria@texim-europe.com)

## Nordic region



Sdr. Jagtvej 12  
DK-2970 Hørsholm

T: +45 88 20 26 30  
F: +45 88 20 26 39  
E: [nordic@texim-europe.com](mailto:nordic@texim-europe.com)

## Italy



Via Matteotti 43  
IT-20864 Agrate Brianza (MB)

T: +39 (0)39 971 3293  
F: +39 (0)39 971 3293  
E: [italy@texim-europe.com](mailto:italy@texim-europe.com)

## General information



[info@texim-europe.com](mailto:info@texim-europe.com)  
[www.texim-europe.com](http://www.texim-europe.com)