

This is a controlled document.  
Check on Batam-intranet or SAP system for latest update.

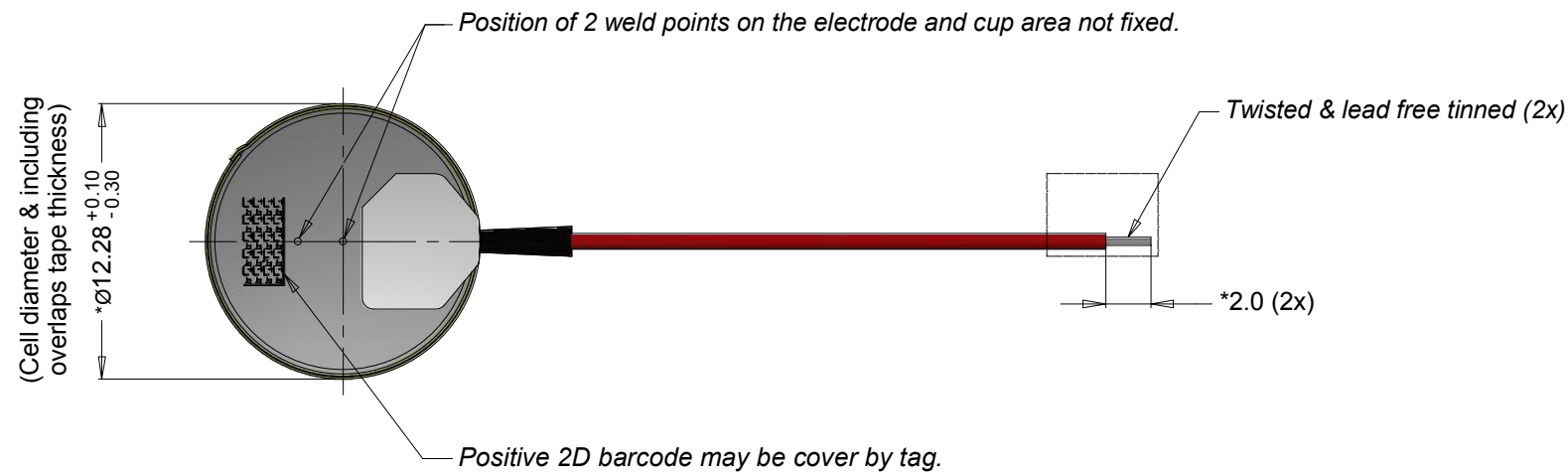

View C  
Scale 5 : 1

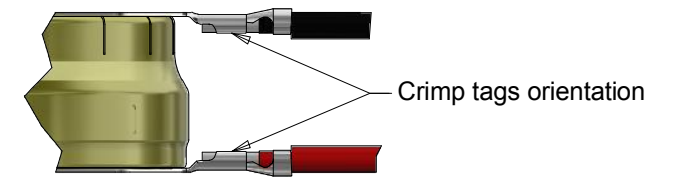

View without kapton tapes

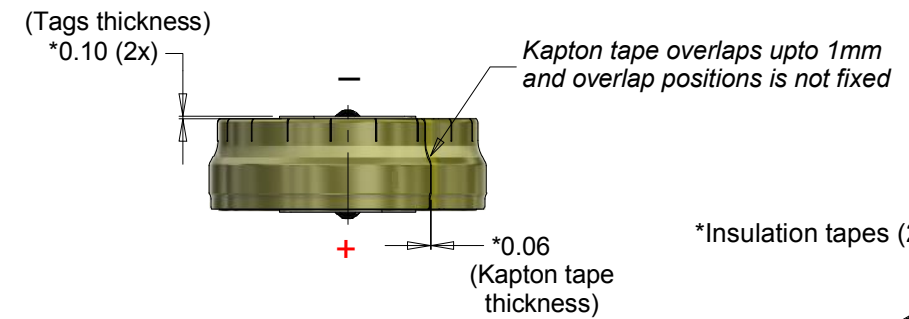
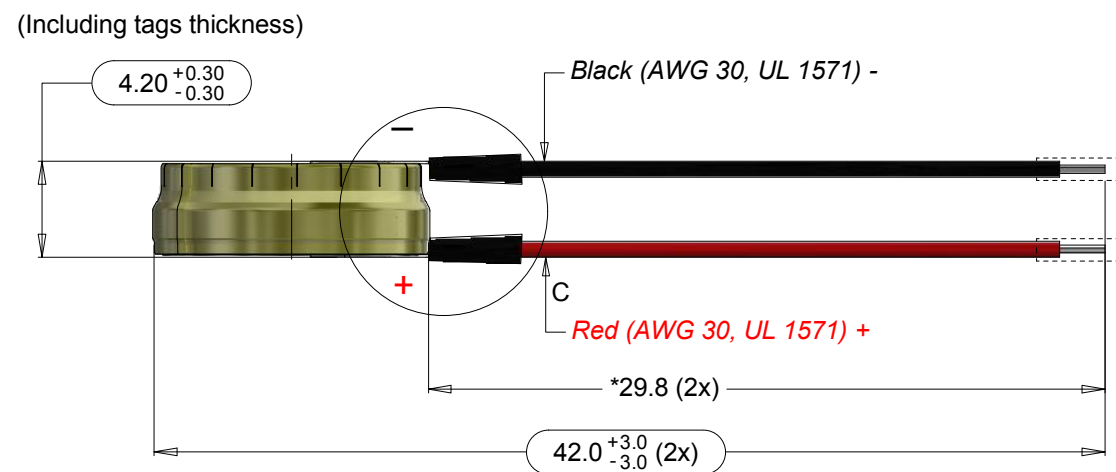
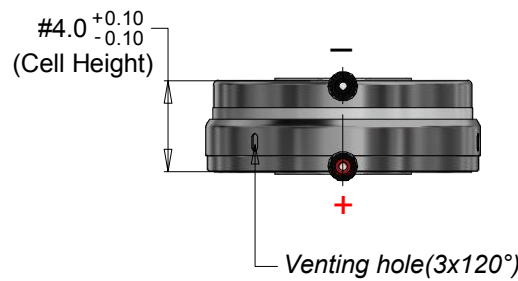

VARTA marking orientation for reference only, these marking may be covered.

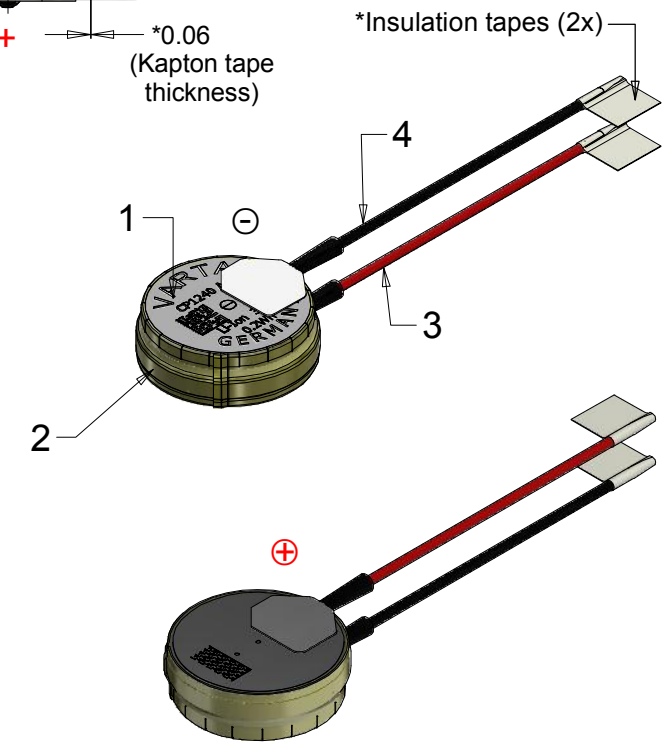
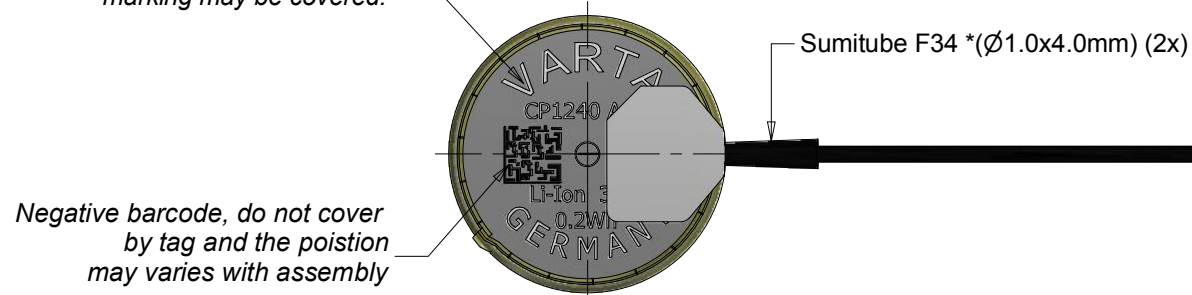

Approx. wt : 1.5 g

- Note : 1) \*Dimensions for reference only.  
 2)  $\varnothing$  Dimensions to be considered for measurement.  
 3) ##Cell deflection space needs to be considered, therefore observe CoinPower Handling Precautions  
 4) BATTERY VALIDATION INCLUDING SAFETY ELECTRONICS MUST BE DONE BY CUSTOMER ACCORDING TO UL 2054.

0	22-N035	Initial released (refer to preliminary drawing P60-00521 rev.101.	2022-11-08	Tholib S
No	AO No	Revision	Date	Name
Projection :		Material : Refer to part list no. : 806006	Description : CP1240 A4X IP W SOC 30% crimp tags with wires	
Dimension in mm		Date	Name	Dwg. No :
Tolerance : As specified		Prepared	Tholib S	806006
Scale : NTS		Checked	Ian	VKB Order No: 63124 201 036
		Approved	Sunil S	
<small>Rights reserved to make technical changes, as a result of further development, without notice. This drawing is the property of VARTA Microbattery and must not be copied or disclosed to a third party without the written consent of VARTA Microbattery.</small>				

