

Distributed by:

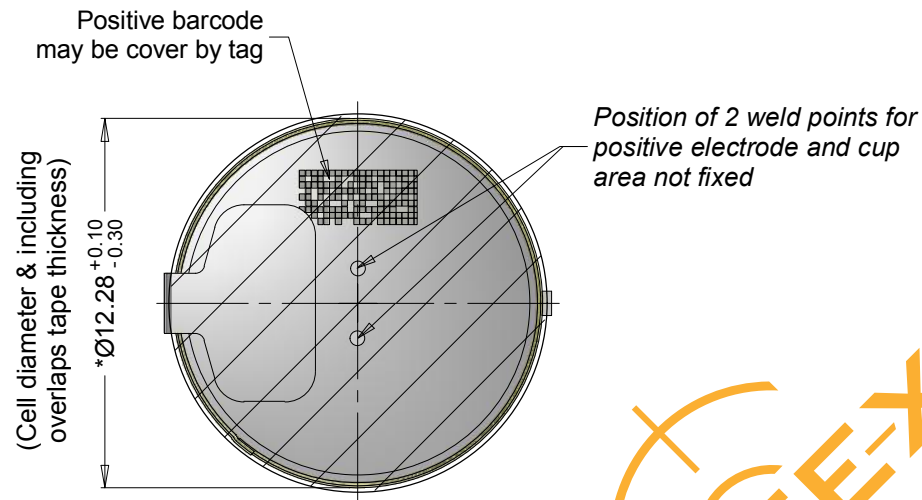

Pre-tinned 3-5µm thick over 2.0±1mm length on both sides.

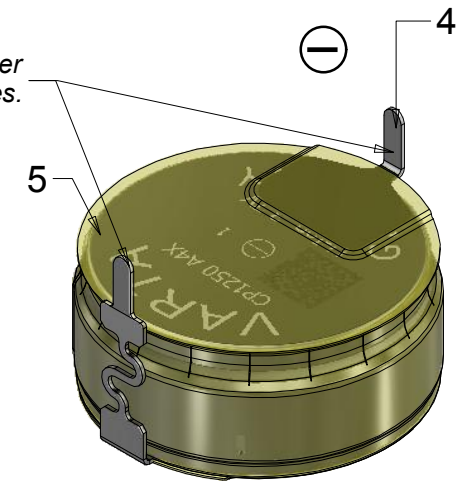

View without kapton tapes

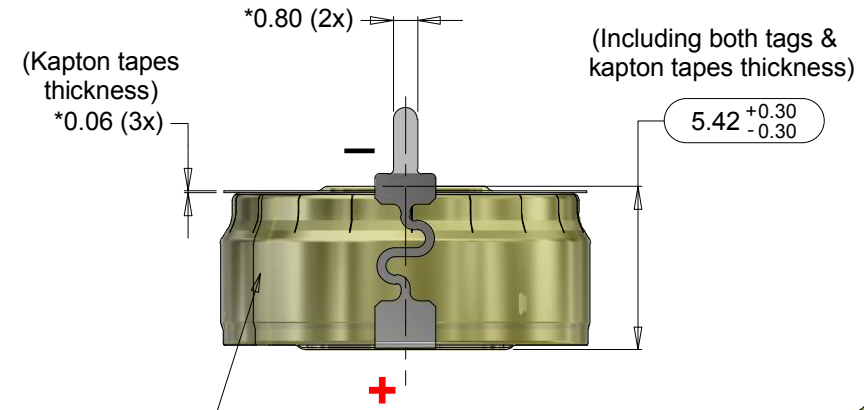
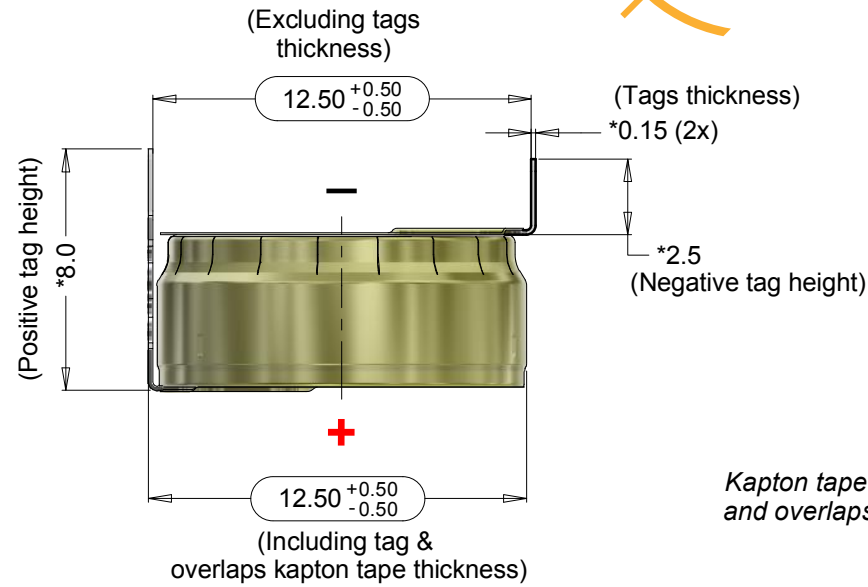
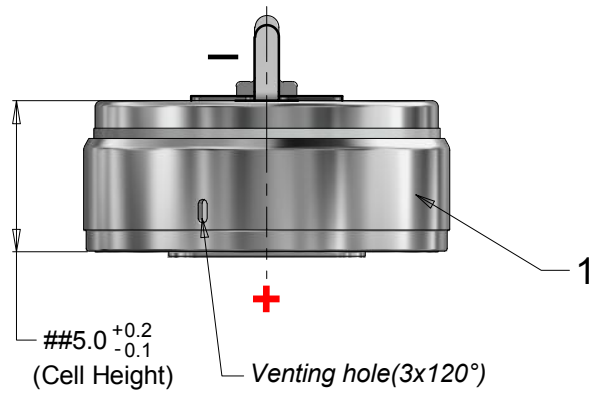

Kapton tape overlaps up to 1mm and overlaps position is not fixed

No expose allowed on positive and negative surface and cover with kapton tape

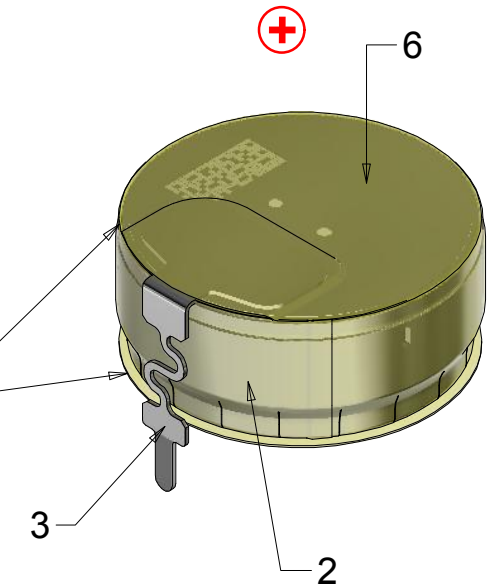

VARTA marking orientation only for reference, these marking may be covered.

Negative barcode, do not cover by tag and the position may varies with assembly.

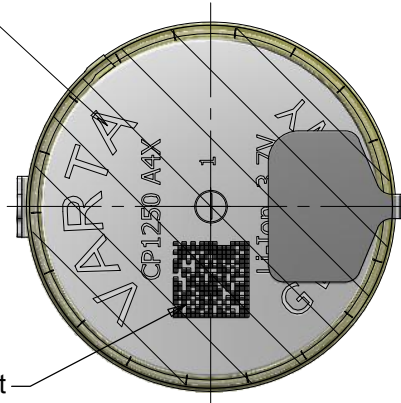

- Note : 1) *Dimensions for reference only.
- 2) Dimensions to be considered for measurement.
- 3) ##Cell deflection space needs to be considered, therefore observe CoinPower Handling Precautions..
- 4) BATTERY VALIDATION INCLUDING SAFETY ELECTRONICS MUST BE DONE BY CUSTOMER ACCORDING TO UL2054.

Approx. wt : 1.9 g

| No | AO No | Revision | Date | Name |
|----|---------|--|------------|----------|
| 1 | 23-R020 | Removed concentricity view and added note "No expose allowed" | 2023-02-06 | Tholib S |
| 0 | 21-N073 | Initial released | 2021-06-28 | Tholib S |

| | | | | | |
|--------------------------|--|------------|-------------------------------|--------------|--|
| Projection : | | Material : | Refer to part list no: 802581 | Description: | CP1250 A4X IP PCBS SOC 30% with solder tags & kapton tapes |
| Dimension in mm | | Prepared | 2021-06-28 | Tholib S | Dwg. No : 802581 |
| Tolerance : As specified | | Checked | 2023-02-06 | Ian | 4 0 1 |
| Scale : NTS | | Approved | 2023-02-06 | Sunil S | VKB Order No : 63121 201 014 |

Rights reserved to make technical changes, as a result of further deployment, without notice. This drawing is the property of VARTA Microbattery and must not be copied or disclosed to a third party without the written consent of VARTA Microbattery.





Headquarters & Warehouse

Elektrostraat 17
NL-7483 PG Haaksbergen
The Netherlands

T: +31 (0)53 573 33 33
E: info@texim-europe.com
Homepage: www.texim-europe.com



The Netherlands

Elektrostraat 17
NL-7483 PG Haaksbergen

T: +31 (0)53 573 33 33
E: nl@texim-europe.com



Belgium

Zuiderlaan 14, box 10
B-1731 Zellik

T: +32 (0)2 462 01 00
E: belgium@texim-europe.com



UK & Ireland

St Mary's House, Church Lane
Carlton Le Moorland
Lincoln LN5 9HS

T: +44 (0)1522 789 555
E: uk@texim-europe.com



Germany - North

Bahnhofstrasse 92
D-25451 Quickborn

T: +49 (0)4106 627 07-0
E: germany@texim-europe.com



Germany - South

Martin-Kollar-Strasse 9
D-81829 München

T: +49 (0)89 436 086-0
E: muenchen@texim-europe.com



Austria

Warwitzstrasse 9
A-5020 Salzburg

T: +43 (0)662 216 026
E: austria@texim-europe.com



Nordic

Søndre Jagtvej 12
DK-2970 Hørsholm

T: +45 88 20 26 30
E: nordic@texim-europe.com



Italy

Via Matteotti 43
IT-20864 Agrate Brianza (MB)

T: +39 (0)39 9713293
E: italy@texim-europe.com