



Shenzhen Leadtek Electronics Co.,Ltd

PRODUCT SPECIFICATION

TFT-LCD MODULE

Module No: LTK088FHHLM01-V0

Preliminary Specification

Approval Specification

Designed by	Checked by	Approved by
<i>jona</i>	<i>tom</i>	<i>lan</i>

Final Approval by Customer

Approved by	Comment

※The specification of "TBD" should refer to the measured value of sample . If there is difference between the design specification and measured value, we naturally shall negotiate and agree to solution with customer.



Revision History

Date	Rev. No.	Page	Summary
2022.02.21	V0		FIRST ISSUE

Contents

1. Block Diagram	5
2. Outline dimension	6
3. Input terminal Pin Assignment	7
4. LCD Optical Characteristics	9
4.1 Optical specification.....	9
5. TFT Electrical Characteristics	12
5.1 Absolute Maximum Rating (Ta=25 VSS=0V).....	12
5.2 DC Electrical Characteristics.....	12
5.3 LED Backlight Characteristics.....	13
6. DC Characteristics	15
6.1 System characteristics.....	15
6.2 MIPI DC Characteristics.....	16
7. AC Characteristics	19
7.1 System AC Characteristics.....	19
7.2 MIPI AC Characteristics.....	19
8. Timing for DSI video mode	21
9. LCD Module Out-Going Quality Level	22
9.1 VISUAL & FUNCTION INSPECTION STANDARD	22
9.1.1 Inspection conditions.....	22
9.1.2 Definition.....	22
9.1.3 Sampling Plan.....	23
9.1.4 Criteria (Visual).....	24
10. Reliability Test Result	30
11. Cautions and Handling Precautions	31
11.1 Handling and Operating the Module.....	31
11.2 Storage and Transportation.....	31
12. Packing	32

* Description

This is a color active matrix TFT (Thin Film Transistor) LCD (liquid crystal display) that uses amorphous silicon TFT as a switching device. This module is composed of a Transmissive type TFT-LCD Panel, driver circuit, back-light unit. The resolution of a 8.88" TFT-LCD contains 480x1920 pixels, and can display up to 16.7M colors.

* Features

General Information Items	Specification	Unit	Note
	Main Panel		
Display area(AA)	54.72(H)*218.88(V) (8.88inch)	mm	-
Driver element	TFT active matrix	-	-
Display colors	16.7M	colors	-
Number of pixels	480(RGB)*1920	dots	-
TFT Pixel arrangement	RGB vertical stripe	-	-
Pixel pitch	0.114(H)*0.114(V)	mm	-
Viewing angle	FREE	o'clock	-
TFT Controller IC	OTA7290	-	-
LCM Interface	4-lane MIPI	-	-
Display mode	Transmissive/Normally Black	-	-
Operating temperature	-30~+85	°C	-
Storage temperature	-40~+90	°C	-

* Mechanical Information

Item		Min.	Typ.	Max.	Unit	Note
FOG size	Horizontal(H)		64.1		mm	-
	Vertical(V)		231.2		mm	-
	Depth(D)		4.73		mm	-
Weight			TBD		g	-

1. Block Diagram

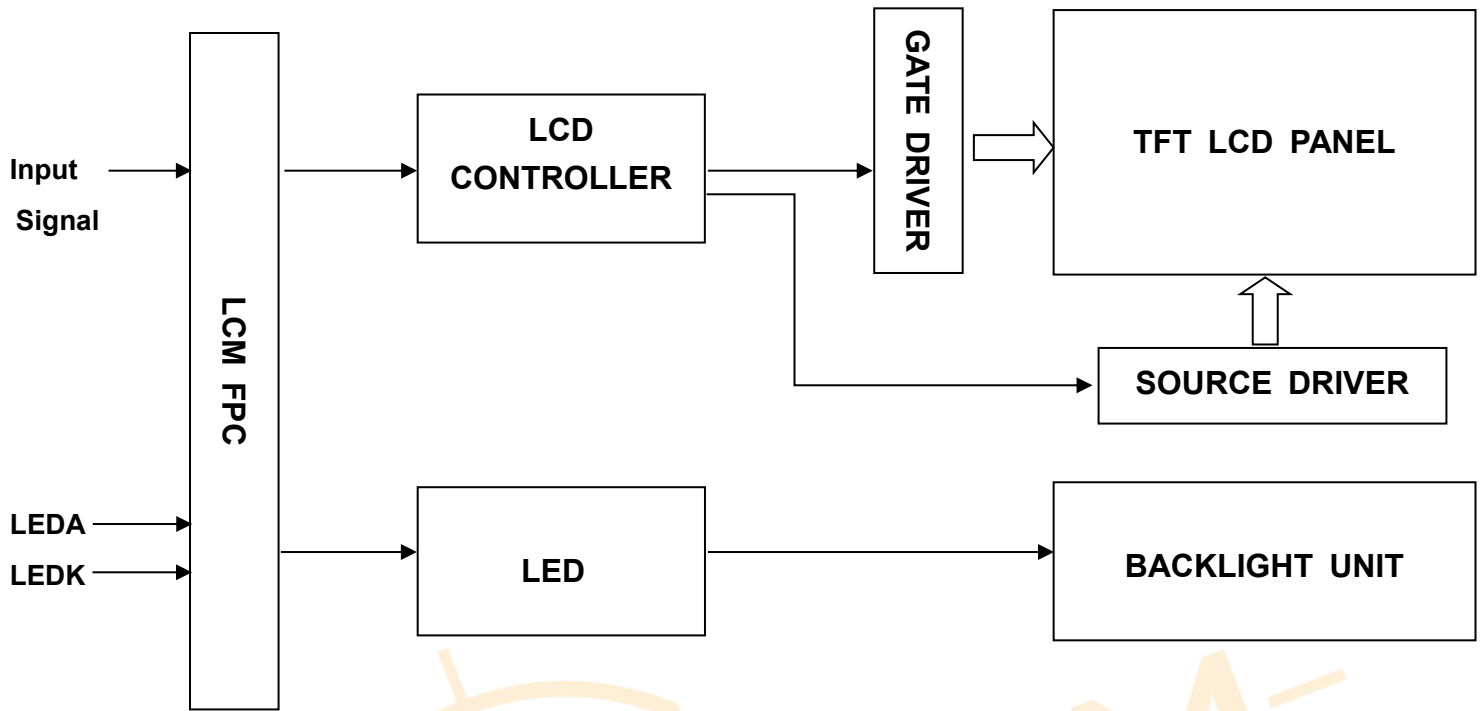

2. Outline dimension

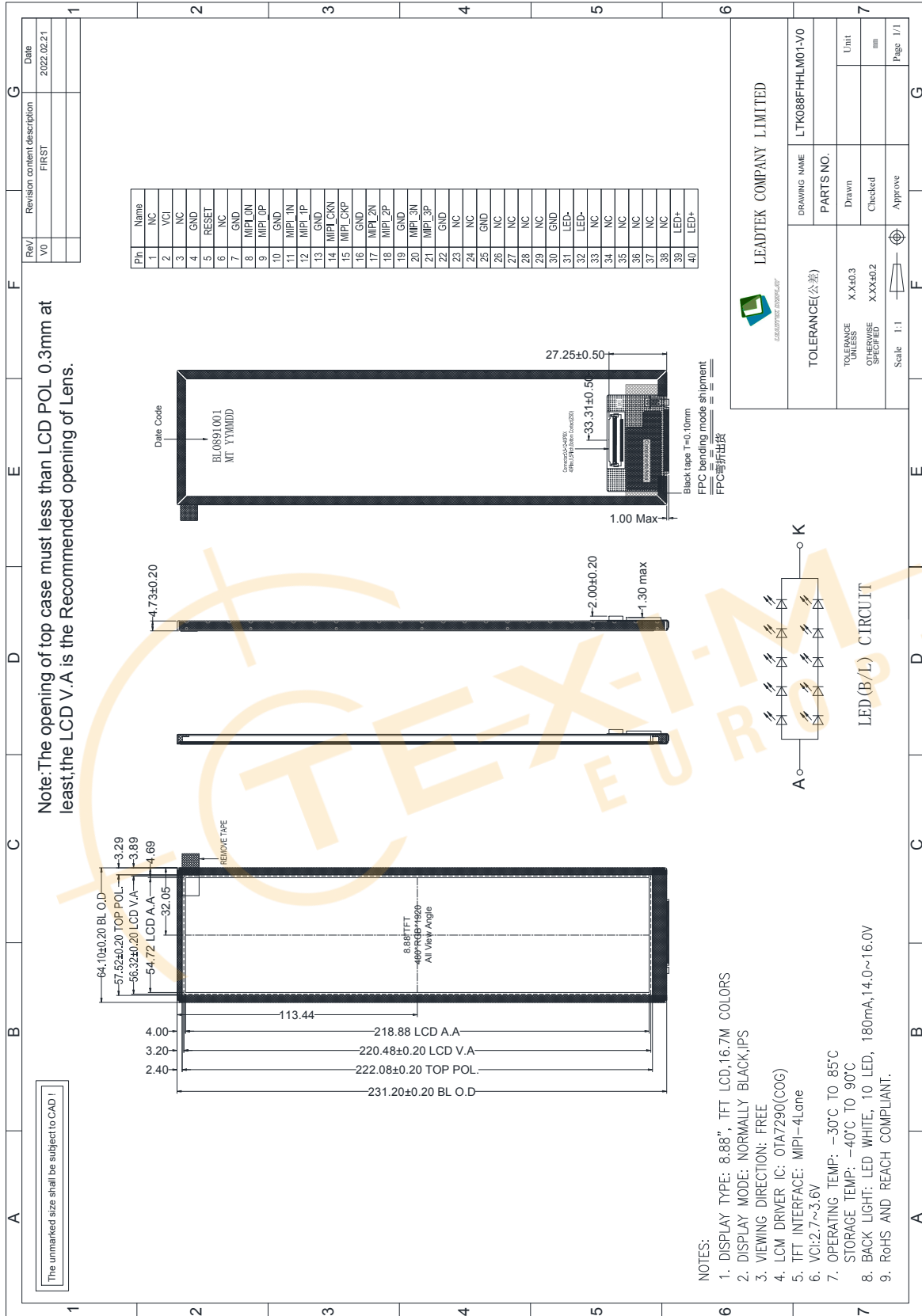

3. Input terminal Pin Assignment

NO.	SYMBOL	DISCRIPTION	I/O
1	NC	No connected	--
2	VCI	Power supply for analog circuits.	P
3	NC	No connected	--
4	GND	Ground	P
5	RESET	Device reset signal.	I
6	NC	No connected	--
7	GND	Ground	P
8	MIPI_0N	MIPI Negative data signal (-)	I
9	MIPI_0P	MIPI Positive data signal (+)	I
10	GND	Ground	P
11	MIPI_1N	MIPI Negative data signal (-)	I
12	MIPI_1P	MIPI Positive data signal (+)	I
13	GND	Ground	P
14	MIPI_CKN	MIPI Negative clock signal (-)	I
15	MIPI_CKP	MIPI Positive clock signal (+)	I
16	GND	Ground	P
17	MIPI_2N	MIPI Negative data signal (-)	I
18	MIPI_2P	MIPI Positive data signal (+)	I
19	GND	Ground	P
20	MIPI_3N	MIPI Negative data signal (-)	I
21	MIPI_3P	MIPI Positive data signal (+)	I
22	GND	Ground	P
23	NC	No connected	--
24	NC	No connected	--
25	GND	Ground	P
26	NC	No connected	--
27	NC	No connected	--
28	NC	No connected	--
29	NC	No connected	--
30	GND	Ground	P
31	LED-	LED Cathode	P
32	LED-	LED Cathode	P
33	NC	No connected	--

34	NC	No connected	--
35	NC	No connected	--
36	NC	No connected	--
37	NC	No connected	--
38	NC	No connected	--
39	LED+	LED anode	P
40	LED+	LED anode	P



4. LCD Optical Characteristics

4.1 Optical specification

Item	Symbol	Condition	Min.	Typ.	Max.	Unit.	Note
Contrast Ratio	CR	$\Theta=0$	640	800	--		(1)(2)
Response time	Rising	T_{R+T_F}	--	40	--	msec	(1)(3)
	Falling						
Color Gamut	S(%)		43	48	--	%	
Color Filter Chromaticity	White	W_X	0.249	0.289	0.329	CF glass	(1)(4)
		W_Y	0.275	0.315	0.355		
	Red	R_X	0.553	0.593	0.633		
		R_Y	0.311	0.351	0.391		
	Green	G_X	0.263	0.303	0.343		
		G_Y	0.495	0.535	0.575		
	Blue	B_X	0.108	0.148	0.188		
		B_Y	0.069	0.109	0.149		
Viewing angle	Hor.	Θ_L	--	80	--	CR>10	(1)(4)
		Θ_R	--	80	--		
	Ver.	Θ_U	--	80	--		
		Θ_D	--	80	--		
Option View Direction			Free				

*The data comes from the LCD specification.

Measuring Condition

Measuring surrounding : dark room

Ambient temperature : $25 \pm 2^\circ\text{C}$

15min. warm-up time.

Measuring Equipment

FPM520 of Westar Display technologies, INC., which utilized SR-3 for Chromaticity and BM-5A for other optical characteristics.

Note (1): Definition of Viewing Angle :

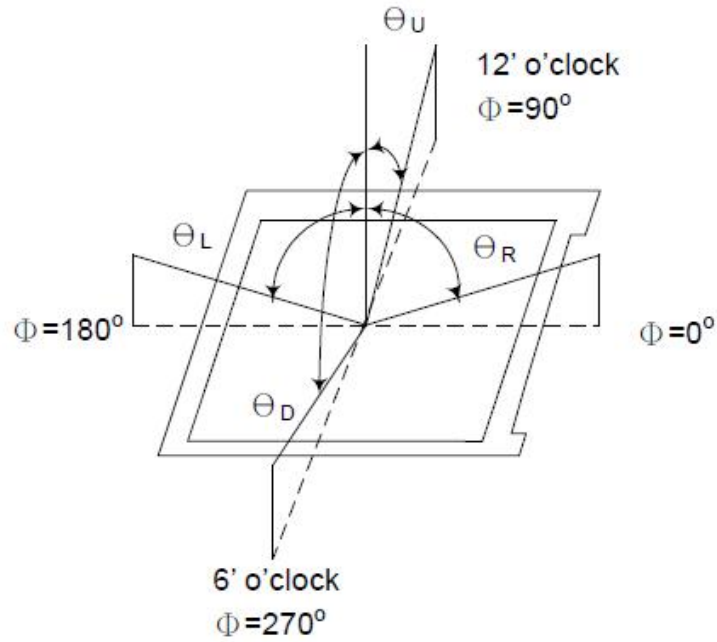

Note (2): Definition of Contrast Ratio(CR) :measured at the center point of panel

$$CR = \frac{\text{Luminance with all pixels white}}{\text{Luminance with all pixels black}}$$

Note (3): Response Time

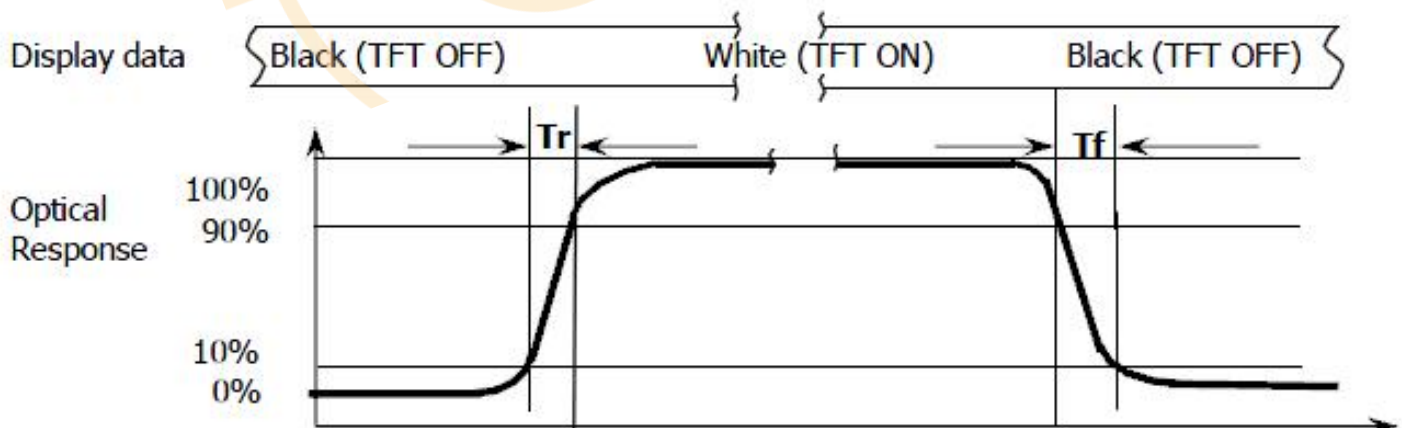

Note (4): Definition of optical measurement setup

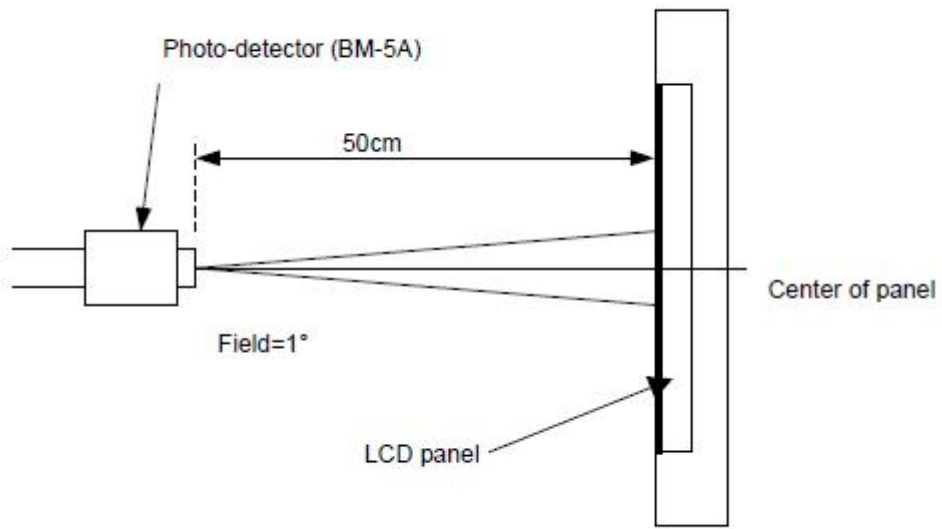

5. TFT Electrical Characteristics

5.1 Absolute Maximum Rating (Ta=25 VSS=0V)

Characteristics	Symbol	Min.	Max.	Unit	Note
Digital Supply Voltage	V _{CI}	-0.5	4.0	V	Note1
Operating temperature	T _{OP}	-30	+85	°C	
Storage temperature	T _{ST}	-40	+90	°C	

NOTE1: If the absolute maximum rating of even is one of the above parameters is exceeded even momentarily, the quality of the product may be degraded. Absolute maximum ratings, therefore, specify the values exceeding which the product may be physically damaged. Be sure to use the product within the range of the absolute maximum ratings.

5.2 DC Electrical Characteristics

Characteristics	Symbol	Min.	Typ.	Max.	Unit	Note
Digital Supply Voltage	V _{CI}	2.7	3.3	3.6	V	--
Normal mode Current consumption	I _{DD}	--	190	380	mA	--
Level input voltage	V _{IH}	0.7 V _{CI}	--	V _{CI}	V	--
	V _{IL}	GND	--	0.3 V _{CI}	V	--
Level output voltage	V _{OH}	0.8* V _{CI}	--	V _{CI}	V	--
	V _{OL}	GND	--	0.2V _{CI}	V	--

5.3 LED Backlight Characteristics

The back-light system is edge-lighting type with 10 chips White LED

Item	Symbol	Min.	Typ.	Max.	Unit	Note
Forward Current	I_F	--	180	--	mA	
Forward Voltage	V_F	14	15	16	V	--
LCM Luminance $I_F=180\text{mA}$	L_V	900	1050	--	cd/m ²	Note3
LED life time	Hr	50000	--	--	Hour	Note1,2
Uniformity	AVg	80	--	--	%	Note3

Note1: LED life time (Hr) can be defined as the time in which it continues to operate under the condition:

$T_a=25\pm 3\text{ }^\circ\text{C}$, typical IL value indicated in the above table until the brightness becomes less than 50%.

Note 2: The "LED life time" is defined as the module brightness decrease to 50% original brightness at

$T_a=25\text{ }^\circ\text{C}$ and $I_L=180\text{mA}$. The LED lifetime could be decreased if operating I_L is larger than 180mA. The constant current driving method is suggested.

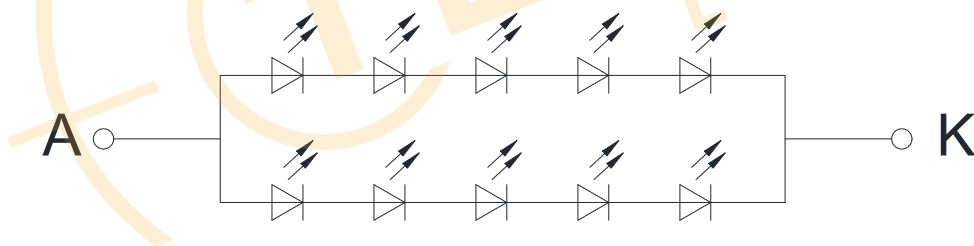

LED (B/L) CIRCUIT

NOTE 3: Luminance Uniformity of these 9 points is defined as below:

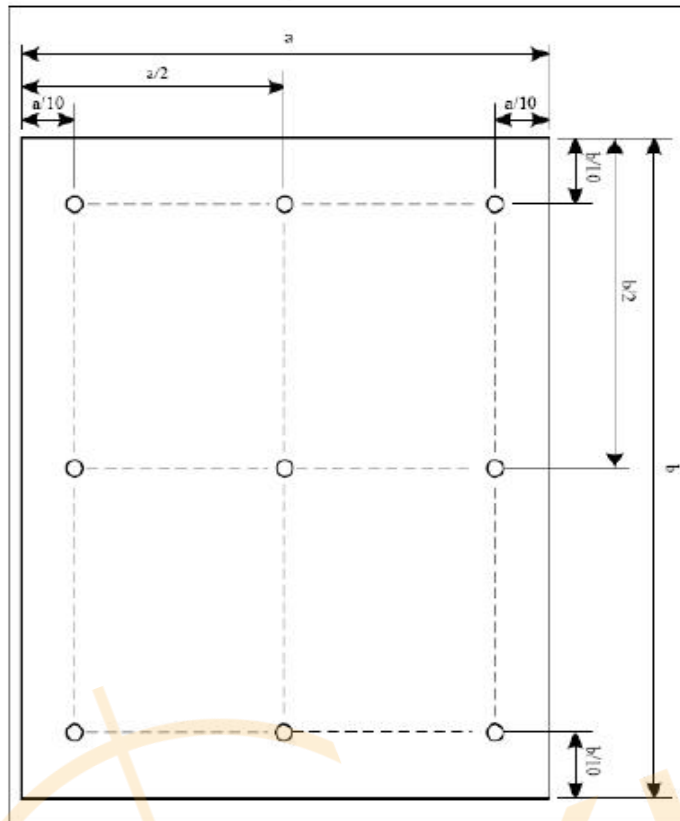

$$\text{Uniformity} = \frac{\text{minimum luminance in 9 points (1-9)}}{\text{maximum luminance in 9 points (1-9)}}$$

$$\text{Luminance} = \frac{\text{Total Luminance of 9 points}}{9}$$

6. DC Characteristics

6.1 System characteristics

(VCC=1.5V, VDD=3.3V, AVDD=12V, VSS=VSSA=0V, TA=-20 to +85°C)

Parameter	Symbol	MIN.	Typ.	MAX.	UNIT	Conditions
VDD Input low voltage level	Vil1	0	-	0.3*VDD	V	For the VDD domain inputs.
VDD Input high voltage level	Vih1	0.7*VDD	-	VDD	V	For the VDD domain inputs.
VCC Input low voltage level	Vil2	0	-	0.2*VCC	V	For the VCC domain inputs.
VCC Input high voltage level	Vih2	0.8*VCC	-	VCC	V	For the VCC domain inputs.
I2C Low level input voltage	Vil3	1.65		VDD	V	For SDA/SCL inputs
I2C High level input voltage	Vih3	0		0.2	V	For SDA/SCL inputs
Input leakage current	Ii	-	-	+/- 1	µA	For the digital, I/O circuit (Not include the pull-up/down current)
Output high voltage level	Voh	0.8*VDD	-	-	V	For VDD domain outputs, Ioh = 400µA
Output low voltage level	Vol	-	-	0.2*VDD	V	For VDD domain outputs, Iol = 400µA
Differential input leakage Current	I _{DIFF}	-10		+10	µA	For DxP, DxN, CLKP, CLKN (With steady state inputs)
Pull low/high resistor	Ri	100K	250K	500K	ohm	For the digital Input pin VDD=3.3, VCC=1.5
Output Voltage deviation	VOD1		±20	±35	mV	Vo = AGND+0.2V ~ AGND+1.5V Vo = HAVDD-0.2V ~ HAVDD-1.5V Vo = HAVDD+0.2V ~ HAVDD+1.5V
Output Voltage deviation	VOD2		±15	±20	mV	Vo = AGND+0.2V ~ AGND+1.5V Vo = AGND+1.5V ~ HAVDD-1.5V Vo = HAVDD+1.5V ~ AVDD-1.5V
Output Voltage Offset between Chips	VOC			±20		Vo = AGND+1.5V ~ HAVDD-1.5V Vo = HAVDD+1.5V ~ AVDD-1.5V
Input level of V1 ~ V7	Vref1	HAVDD+0.2	-	AVDD-0.2	V	Gamma positive voltage input
Input level of V8 ~ V14	Vref2	0.2	-	HAVDD-0.2	V	Gamma negative voltage input
Dynamic Range of Output	Vdr	0.2	-	AVDD-0.2	V	S0 ~ S1802
Sinking Current of Outputs	IOLy	80	-	-	µA	S0 ~ S1802
Driving Current of Outputs	IOHy	80	-	-	µA	S0 ~ S1802
Digital Operation current	Idd	-	TBD	-	mA	
Digital Stand-by current	Ist1	-	1.15	2.5	mA	
Analog Operation current	Idda	-	TBD	-	mA	
Analog Stand-by current	Ist2	-	3.5	6.9	mA	

6.2 MIPI DC Characteristics

HS Receiver DC Specification

Parameter	Symbol	Rating			Unit	Note
		Min	Typ	Max		
Operation Voltage	VDD	1.5-10%	1.5	1.5+10%	mV	
Differential Input Voltage	VID	70	200	260	mV	
Common Mode Voltage	V _{CMRX(DC)}	70	-	330	mV	
Differential Input High Threshold Voltage	V _{TH}	-	-	70	mV	
Differential Input Low Threshold Voltage	V _{TL}	-70	-	-	mV	
Singled-ended input high voltage	V _{IHHS}	-	-	460	mV	
Singled-ended input low voltage	V _{ILHS}	-40	-	-	mV	
Singled-ended threshold for HS termination enable	V _{TERM-EN}	-	-	450	mV	
Differential input impedance	Z _{ID}	80	100	125	ohm	
Pin leakage current	I _{LEAK}	-10	-	10	uA	
Common-mode interference beyond 450MHz	ΔV _{CMRX(HF)}	-	-	100	mV	
Common-mode interference 50MHz - 450MHz	ΔV _{CMRX(LF)}	-50	-	50	mV	
Common-mode termination	C _{CM}	-	-	60	pF	
Embedded Termination	R _T	90	100	110	ohm	2bits RT_SEL[1: 0] for termination resistor selection 00 → 200ohm 10 , 01 → 150ohm 11 → 100ohm (default) 1bit ERM _R _EN for termination resistor enable TERM _R _EN=0, termr disable R=(OPEN) TERM _R _EN=1, termr enable

Note:

- (1) Excluding possible additional RF interference of 100mV peak sine wave beyond 450MHz.
- (2) This table value includes a ground difference of 50mV between the transmitter and the receiver, the static common-mode level tolerance and variations below 450MHz.

LP Receiver DC Specification

Parameter	Symbol	Rating			Unit	Note
		Min	Typ	Max		
Logic 1 input voltage	V_{IH}	880	-	-	mV	
Logic 0 input voltage, not in ULP State	V_{IL}	-	-	550	mV	
Input hysteresis	V_{HYST}	25	-	-	mV	

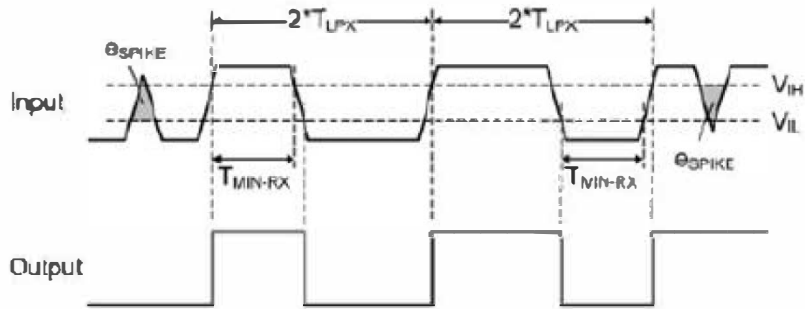

Line Contention Detection

Parameter	Symbol	Rating			Unit	Note
		Min	Typ	Max		
Logic 1 contention threshold	V_{IHCD}	450	-	-	mV	
Logic 0 contention threshold	V_{ILCD}	-	-	200	mV	

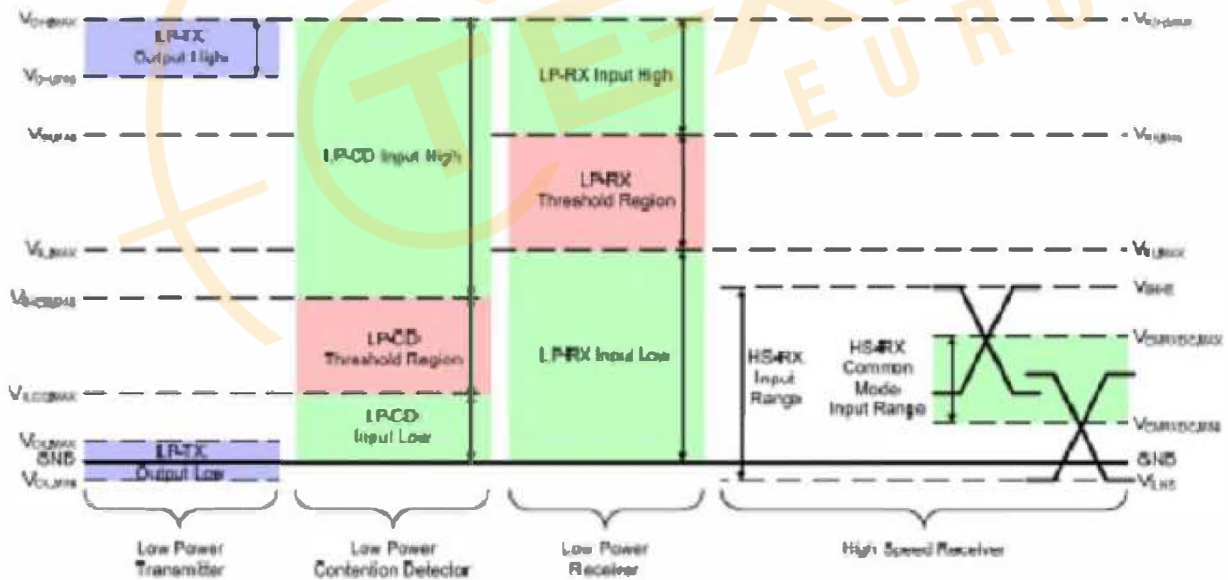

Input Characteristics

Parameter	Symbol	Rating			Unit	Note
		Min	Typ	Max		
Pin signal voltage range	V_{PIN}	-50		1350	mV	
Pin leakage current	I_{LEAK}	-10		10	uA	
Ground shift	V_{GNDSH}	-50		50	mV	
Transient pin voltage level	$V_{PIN(3\sigma\max)}$	-0.15		1.45	V	
Maximum transient time above $V_{PIN(\max)}$ or below $V_{PIN(\min)}$	$TV_{PIN(3\sigma\max)}$			20	ns	

Note:

- (1) When the pad voltage is in the signal voltage range from $V_{GNDSH, MIN}$ to $VOH + V_{GNDSH, MAX}$ and the Lane Module is in LP receive mode.
- (2) The voltage overshoot and undershoot beyond the V_{PIN} is only allowed during a single 20ns window after any LP-0 to LP-1 transition or vice versa. For all other situations it must stay within the V_{PIN} range.
- (3) This value includes ground shift.



7. AC Characteristics

7.1 System AC Characteristics

(VDD=3.3V, AVDD=12V, VSS=VSSA=0V, TA=-20 to +85°C)

Parameter	Symbol	MIN.	Typ.	MAX.	UNIT	Conditions
VDD Power On Slew rate	T	-	-	20	ms	From VSS to 90% VDD
RSTB pulse width	T	10	-	-	us	

7.2 MIPI AC Characteristics

HS Receiver AC Timing Characteristics

Parameter	Symbol	Rating			Unit	Note
		Min	Typ	Max		
Bandwidth per lane	-	-	-	1000	Mbps	Bandwidth selected by register 'speedup' Speedup=0 → Max=550Mbps Speedup=1 → Max=1000Mbps
Operation frequency	-	-	-	500	MHz	
UI instantaneous	UI _{INST}	1	-	12.5	ns	1
Data to Clock Skew	T _{skew}	-0.15	-	0.15	UI _{INST}	
Inter-lane static skew	T _{skew-lane}	-	-	UI _{INST} /50	UI _{INST}	
Data to Clock Setup Time	T _{SETUP}	0.25	-	-	UI _{INST}	2
Data to Clock Hold Time	T _{HOLD}	0.25	-	-	UI _{INST}	
Common-mode interference beyond 450MHz	ΔV _{CMRX(HF)}	-	-	100	mV	4
Common-mode interference 50MHz- 450MHz	ΔV _{CMRX(LF)}	-50	-	50	mV	3,6
Common-mode termination	C _{CM}	-	-	60	pF	5

Note:

- (1) Total silicon and package delay budget of $0.3 \cdot UI_{INST}$
- (2) Total setup and hold window for receiver of $0.3 \cdot UI_{INST}$
- (3) Excluding 'static' ground shift of 50mV
- (4) ΔV_{CMRX} (HF) is the peak amplitude of a sine wave superimposed on the receiver input
- (5) For higher bit rates a 14pF capacitor will be needed to meet the common-mode return loss specification.
- (6) Voltage difference compared to the DC average common-mode potential.

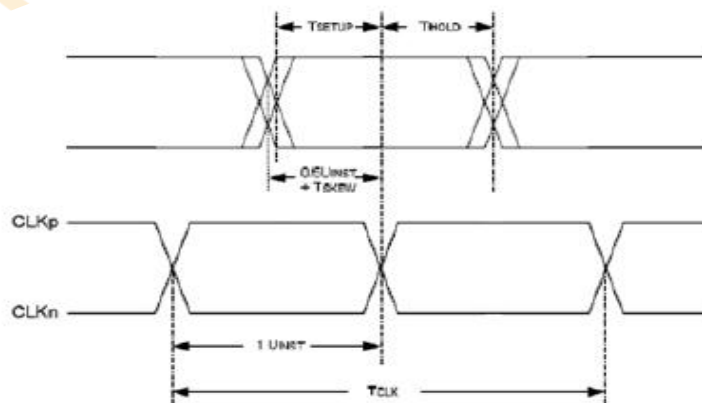

LP Receiver AC Timing Characteristics

Parameter	Symbol	Rating			Unit	Note
		Min	Typ	Max		
Input pulse rejection	e_{SPIKE}	-	-	300	V-ps	1,2,3
Minimum pulse width response	$T_{\text{MIN-FX}}$	20	-	-	ns	
Peak interference amplitude	V_{INT}	-	-	200	mV	
Interference frequency	f_{INT}	450	-	-	MHz	
Logic 1 input voltage	V_{IH}	880	-	-	mV	
Logic 0 input voltage, not in ULP State	V_{IL}	-	-	550	mV	
Logic 0 input voltage, ULP State	$V_{\text{IL-ULPS}}$	-	-	300	mV	
Input Hysteresis	V_{HYST}	25	-	-	mV	
Logic 1 contention threshold	V_{IHCD}	450	-	-	mV	
Logic 0 contention threshold	V_{ILCD}	-	-	200	mV	

Note:

- (1) Time-voltage integration of a spike above V_{IL} when being in LP-0 state or below V_{IH} when being in LP-1 state.
- (2) An impulse less than this will not change the receiver state.
- (3) In addition to the required glitch rejection, implementers shall ensure rejection of known RF-interferers.

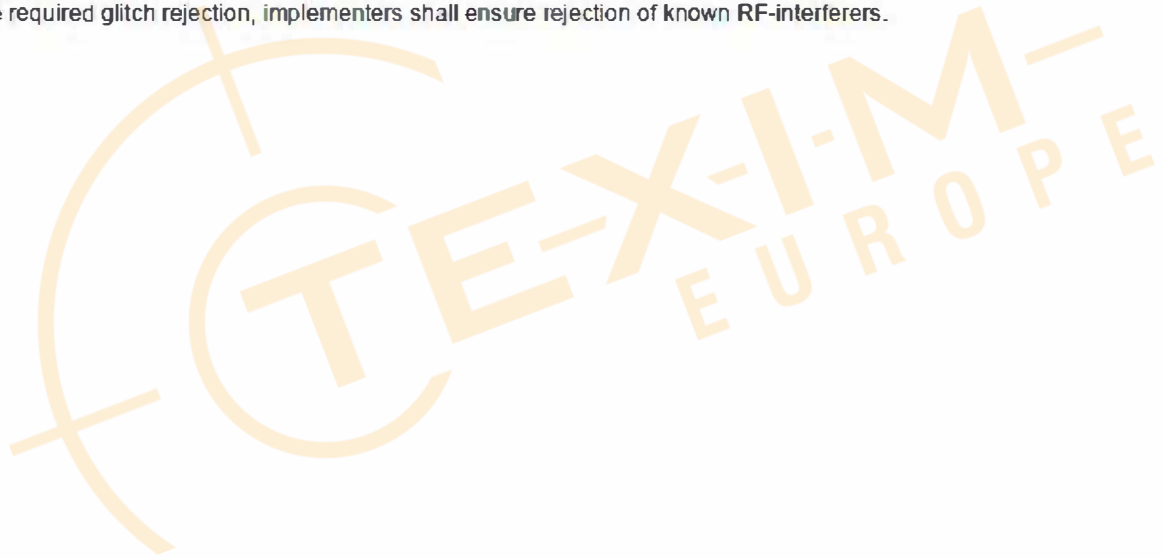

8. Timing for DSI video mode

Parameter	Symbol	Min.	Typ.	Max.	Unit
DCLK frequency	FCLK	--	(71)	--	MHz
Horizontal display area	HDISP	--	480	--	Clock
Horizontal Sync. Width	hpw	5	10	50	Clock
Horizontal Sync. Back Porch	hbp	35	50	100	Clock
Horizontal Sync. Front Porch	hfp	35	50	200	Clock
Vertical display area	VDISP	--	1920	--	Line
Vertical Sync. Width	vs	10	20	50	Line
Vertical Sync. Back Porch	vbp	20	30	100	Line
Vertical Sync. Front Porch	vfp	20	30	200	Line
Frame-Rate	Fr	--	60	--	Hz

Note:

The best frame rate setting : 2 data lanes : 50~60 Hz / 3 data lanes : 50~70 Hz / 4 data lanes : 50~70 Hz.

9. LCD Module Out-Going Quality Level

9.1 VISUAL & FUNCTION INSPECTION STANDARD

9.1.1 Inspection conditions

Inspection performed under the following conditions is recommended.

Temperature : $25\pm 5^{\circ}\text{C}$

Humidity : $65\%\pm 10\%\text{RH}$

Viewing Angle : Normal viewing Angle.

Illumination: Single fluorescent lamp (300 to 700Lux)

Viewing distance:30-50cm

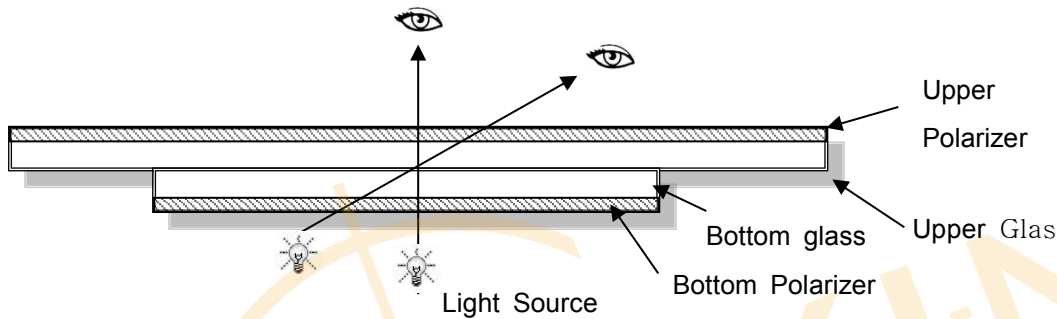

9.1.2 Definition

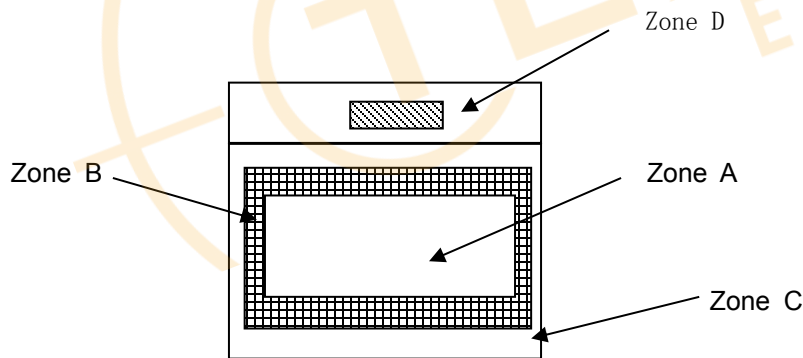

Zone A : Effective Viewing Area(Character or Digit can be seen)

Zone B : Viewing Area except Zone A

Zone C : Outside (Zone A+Zone B) which can not be seen after assembly by customer .)

Zone D : IC Bonding Area

Note:As a general rule ,visual defects in Zone C can be ignored when it doesn't effect product function or appearance after assembly by customer

9.1.3 Sampling Plan

According to GB/T 2828-2003 ; , normal inspection, Class II

AQL:

Major defect	Minor defect
0.65	1.5

LCD: Liquid Crystal Display , LCM: Liquid Crystal Module, CTP: Capacitive Touch Panel

No	Items to be inspected	Criteria	Classification of defects
1	Functional defects	1) No display, Open or miss line 2) Display abnormally, Short 3) Backlight no lighting, abnormal lighting. etc	Major
2	Missing	Missing components and etc	
3	Outline dimension	Overall outline dimension beyond the drawing is not allowed, deformation and etc	
4	Color tone	Color unevenness, refer to limited sample	Minor
5	Spot/Line defect	Light dot, Dim spot, (Note1) Polarizer Air Bubble, Polarizer accidented spot and etc	
6	Soldering appearance	Good soldering , Peeling off is not allowed and etc	
7	LCD/Polarizer/CTP	Black/White spot/line, scratch, crack, etc.	

Note1: a) Light dot: Dots appear bright and unchanged in size in which LCD panel is displaying under black pattern.

b) Dim dot: Dots appear dark and unchanged in size in which LCD panel is displaying under pure red, green, blue picture.

9.1.4 Criteria (Visual)

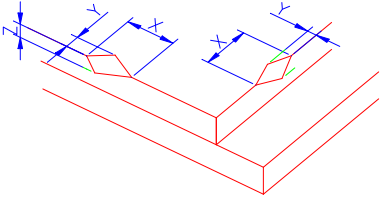
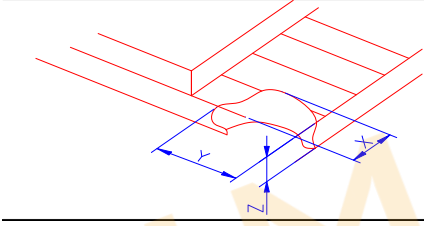
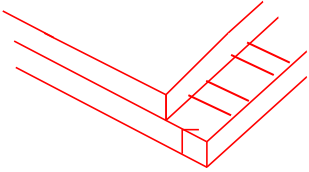
Number	Items	Criteria(mm)						
1.0 LCD Crack/Broken NOTE: X: Length Y: Width Z: Height L: Length of IT O, T: Height of LCD	(1) The edge of LCD broken	 <table border="1" data-bbox="756 667 1455 815"> <thead> <tr> <th>X</th> <th>Y</th> <th>Z</th> </tr> </thead> <tbody> <tr> <td>≤3.0mm</td> <td><Inner border line of the seal</td> <td>≤T</td> </tr> </tbody> </table>	X	Y	Z	≤3.0mm	<Inner border line of the seal	≤T
	X	Y	Z					
	≤3.0mm	<Inner border line of the seal	≤T					
(2) LCD corner broken	 <table border="1" data-bbox="836 1124 1375 1223"> <thead> <tr> <th>X</th> <th>Y</th> <th>Z</th> </tr> </thead> <tbody> <tr> <td>≤3.0mm</td> <td>≤L</td> <td>≤T</td> </tr> </tbody> </table>	X	Y	Z	≤3.0mm	≤L	≤T	
X	Y	Z						
≤3.0mm	≤L	≤T						
(3) LCD crack	 <p style="text-align: center;">Crack Not allowed</p>							

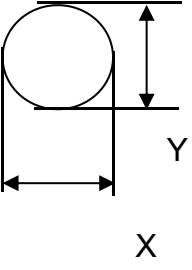
2.0  <p>$\Phi=(X+Y)/2$</p>	Spot defect	① light dot (black/white spot , pinhole, stain, etc.)																																															
	<table border="1"> <thead> <tr> <th rowspan="2">Zone Size (mm)</th> <th colspan="3">Acceptable Qty</th> </tr> <tr> <th>A</th> <th>B</th> <th>C</th> </tr> </thead> <tbody> <tr> <td>$\Phi \leq 0.15$</td> <td colspan="3">Ignore</td> </tr> <tr> <td>$0.15 < \Phi \leq 0.25$</td> <td colspan="3">3(distance ≥ 10mm)</td> </tr> <tr> <td>$0.25 < \Phi \leq 0.4$</td> <td colspan="3">2(distance ≥ 10mm)</td> </tr> <tr> <td>$\Phi > 0.4$</td> <td colspan="3">0</td> </tr> </tbody> </table>	Zone Size (mm)	Acceptable Qty			A	B	C	$\Phi \leq 0.15$	Ignore			$0.15 < \Phi \leq 0.25$	3(distance ≥ 10 mm)			$0.25 < \Phi \leq 0.4$	2(distance ≥ 10 mm)			$\Phi > 0.4$	0			<table border="1"> <thead> <tr> <th rowspan="2">Zone Size (mm)</th> <th colspan="3">Acceptable Qty</th> </tr> <tr> <th>A</th> <th>B</th> <th>C</th> </tr> </thead> <tbody> <tr> <td>$\Phi \leq 0.15$</td> <td colspan="3">Ignore</td> </tr> <tr> <td>$0.15 < \Phi \leq 0.25$</td> <td colspan="3">3(distance ≥ 10mm)</td> </tr> <tr> <td>$0.25 < \Phi \leq 0.4$</td> <td colspan="3">2(distance ≥ 10mm)</td> </tr> <tr> <td>$\Phi > 0.4$</td> <td colspan="3">0</td> </tr> </tbody> </table>		Zone Size (mm)	Acceptable Qty			A	B	C	$\Phi \leq 0.15$	Ignore			$0.15 < \Phi \leq 0.25$	3(distance ≥ 10 mm)			$0.25 < \Phi \leq 0.4$	2(distance ≥ 10 mm)			$\Phi > 0.4$	0		
	Zone Size (mm)		Acceptable Qty																																														
		A	B	C																																													
	$\Phi \leq 0.15$	Ignore																																															
$0.15 < \Phi \leq 0.25$	3(distance ≥ 10 mm)																																																
$0.25 < \Phi \leq 0.4$	2(distance ≥ 10 mm)																																																
$\Phi > 0.4$	0																																																
Zone Size (mm)	Acceptable Qty																																																
	A	B	C																																														
$\Phi \leq 0.15$	Ignore																																																
$0.15 < \Phi \leq 0.25$	3(distance ≥ 10 mm)																																																
$0.25 < \Phi \leq 0.4$	2(distance ≥ 10 mm)																																																
$\Phi > 0.4$	0																																																
② Dim spot (light leakage, dent, dark spot, etc)	③ Polarizer accidented spot																																																
<table border="1"> <thead> <tr> <th rowspan="2">Zone Size (mm)</th> <th colspan="3">Acceptable Qty</th> </tr> <tr> <th>A</th> <th>B</th> <th>C</th> </tr> </thead> <tbody> <tr> <td>$\Phi \leq 0.2$</td> <td colspan="3">Ignore</td> </tr> <tr> <td>$0.2 < \Phi \leq 0.5$</td> <td colspan="3">2(distance ≥ 10mm)</td> </tr> <tr> <td>$\Phi > 0.5$</td> <td colspan="3">0</td> </tr> </tbody> </table>	Zone Size (mm)	Acceptable Qty			A	B	C	$\Phi \leq 0.2$	Ignore			$0.2 < \Phi \leq 0.5$	2(distance ≥ 10 mm)			$\Phi > 0.5$	0			<table border="1"> <thead> <tr> <th rowspan="2">Zone Size (mm)</th> <th colspan="3">Acceptable Qty</th> </tr> <tr> <th>A</th> <th>B</th> <th>C</th> </tr> </thead> <tbody> <tr> <td>$\Phi \leq 0.2$</td> <td colspan="3">Ignore</td> </tr> <tr> <td>$0.2 < \Phi \leq 0.4$</td> <td colspan="3">2(distance ≥ 10mm)</td> </tr> <tr> <td>$\Phi > 0.4$</td> <td colspan="3">0</td> </tr> </tbody> </table>		Zone Size (mm)	Acceptable Qty			A	B	C	$\Phi \leq 0.2$	Ignore			$0.2 < \Phi \leq 0.4$	2(distance ≥ 10 mm)			$\Phi > 0.4$	0											
Zone Size (mm)		Acceptable Qty																																															
	A	B	C																																														
$\Phi \leq 0.2$	Ignore																																																
$0.2 < \Phi \leq 0.5$	2(distance ≥ 10 mm)																																																
$\Phi > 0.5$	0																																																
Zone Size (mm)	Acceptable Qty																																																
	A	B	C																																														
$\Phi \leq 0.2$	Ignore																																																
$0.2 < \Phi \leq 0.4$	2(distance ≥ 10 mm)																																																
$\Phi > 0.4$	0																																																
④ Polarizer Bubble	④ Polarizer Bubble																																																
<table border="1"> <thead> <tr> <th rowspan="2">Zone Size (mm)</th> <th colspan="3">Acceptable Qty</th> </tr> <tr> <th>A</th> <th>B</th> <th>C</th> </tr> </thead> <tbody> <tr> <td>$\Phi \leq 0.2$</td> <td colspan="3">Ignore</td> </tr> <tr> <td>$0.2 < \Phi \leq 0.4$</td> <td colspan="3">2(distance ≥ 10mm)</td> </tr> <tr> <td>$\Phi > 0.4$</td> <td colspan="3">0</td> </tr> </tbody> </table>	Zone Size (mm)	Acceptable Qty			A	B	C	$\Phi \leq 0.2$	Ignore			$0.2 < \Phi \leq 0.4$	2(distance ≥ 10 mm)			$\Phi > 0.4$	0			<table border="1"> <thead> <tr> <th rowspan="2">Zone Size (mm)</th> <th colspan="3">Acceptable Qty</th> </tr> <tr> <th>A</th> <th>B</th> <th>C</th> </tr> </thead> <tbody> <tr> <td>$\Phi \leq 0.2$</td> <td colspan="3">Ignore</td> </tr> <tr> <td>$0.2 < \Phi \leq 0.4$</td> <td colspan="3">2(distance ≥ 10mm)</td> </tr> <tr> <td>$\Phi > 0.4$</td> <td colspan="3">0</td> </tr> </tbody> </table>		Zone Size (mm)	Acceptable Qty			A	B	C	$\Phi \leq 0.2$	Ignore			$0.2 < \Phi \leq 0.4$	2(distance ≥ 10 mm)			$\Phi > 0.4$	0											
Zone Size (mm)		Acceptable Qty																																															
	A	B	C																																														
$\Phi \leq 0.2$	Ignore																																																
$0.2 < \Phi \leq 0.4$	2(distance ≥ 10 mm)																																																
$\Phi > 0.4$	0																																																
Zone Size (mm)	Acceptable Qty																																																
	A	B	C																																														
$\Phi \leq 0.2$	Ignore																																																
$0.2 < \Phi \leq 0.4$	2(distance ≥ 10 mm)																																																
$\Phi > 0.4$	0																																																

3.0	LCD Pixel defect	<p>Pixel bad points</p> <table border="1" data-bbox="523 309 1484 1055"> <thead> <tr> <th data-bbox="523 309 719 360">Item</th> <th data-bbox="719 309 1233 360">Zone A</th> <th data-bbox="1233 309 1484 360">Acceptable Qt</th> </tr> </thead> <tbody> <tr> <td data-bbox="523 360 719 521" rowspan="3">Bright dot</td> <td data-bbox="719 360 1233 416">Random</td> <td data-bbox="1233 360 1484 416">$N \leq 2$</td> </tr> <tr> <td data-bbox="719 416 1233 472">2 dots adjacent</td> <td data-bbox="1233 416 1484 472">$N \leq 0$</td> </tr> <tr> <td data-bbox="719 472 1233 521">3 dots adjacent</td> <td data-bbox="1233 472 1484 521">$N \leq 0$</td> </tr> <tr> <td data-bbox="523 521 719 689" rowspan="3">Dark dot</td> <td data-bbox="719 521 1233 577">Random</td> <td data-bbox="1233 521 1484 577">$N \leq 3$</td> </tr> <tr> <td data-bbox="719 577 1233 633">2 dots adjacent</td> <td data-bbox="1233 577 1484 633">$N \leq 0$</td> </tr> <tr> <td data-bbox="719 633 1233 689">3 dots adjacent</td> <td data-bbox="1233 633 1484 689">$N \leq 0$</td> </tr> <tr> <td data-bbox="523 689 719 999">Distance</td> <td data-bbox="719 689 1233 999"> 1. Minimum Distance Between Bright dots. 2. Minimum Distance Between dark dots 3. Minimum Distance Between dark and bright dot. </td> <td data-bbox="1233 689 1484 999">5mm</td> </tr> <tr> <td colspan="2" data-bbox="523 999 1233 1055">Total bright and dark dot</td> <td data-bbox="1233 999 1484 1055">$N \leq 4$</td> </tr> </tbody> </table> <p data-bbox="523 1066 603 1099">Note:</p> <p data-bbox="523 1122 1468 1211">A) Bright dot: Dots appear bright and unchanged in size in which LCD panel is displaying under black pattern.</p> <p data-bbox="523 1227 1492 1317">B) Dark dot: Dots appear dark and unchanged in size in which LCD panel is displaying under pure red, green, blue picture.</p> <p data-bbox="523 1373 1075 1413">C) 2 dot adjacent = 1 pair = 2 dots</p> <p data-bbox="523 1424 635 1458">Picture:</p> <div data-bbox="651 1509 730 1570" style="display: inline-block; text-align: center;"> </div> <div data-bbox="571 1615 794 1648" style="display: inline-block; text-align: center;">2 dot adjacent</div> <div data-bbox="1062 1509 1174 1570" style="display: inline-block; text-align: center;"> </div> <div data-bbox="1031 1615 1254 1648" style="display: inline-block; text-align: center;">2 dot adjacent</div> <div data-bbox="663 1675 703 1787" style="display: inline-block; text-align: center;"> </div> <div data-bbox="523 1805 882 1839" style="display: inline-block; text-align: center;">2 dot adjacent (vertical)</div> <div data-bbox="1062 1675 1254 1787" style="display: inline-block; text-align: center;"> </div> <div data-bbox="1031 1805 1350 1839" style="display: inline-block; text-align: center;">2 dot adjacent (slant)</div>	Item	Zone A	Acceptable Qt	Bright dot	Random	$N \leq 2$	2 dots adjacent	$N \leq 0$	3 dots adjacent	$N \leq 0$	Dark dot	Random	$N \leq 3$	2 dots adjacent	$N \leq 0$	3 dots adjacent	$N \leq 0$	Distance	1. Minimum Distance Between Bright dots. 2. Minimum Distance Between dark dots 3. Minimum Distance Between dark and bright dot.	5mm	Total bright and dark dot		$N \leq 4$
Item	Zone A	Acceptable Qt																							
Bright dot	Random	$N \leq 2$																							
	2 dots adjacent	$N \leq 0$																							
	3 dots adjacent	$N \leq 0$																							
Dark dot	Random	$N \leq 3$																							
	2 dots adjacent	$N \leq 0$																							
	3 dots adjacent	$N \leq 0$																							
Distance	1. Minimum Distance Between Bright dots. 2. Minimum Distance Between dark dots 3. Minimum Distance Between dark and bright dot.	5mm																							
Total bright and dark dot		$N \leq 4$																							

4.0	Line defect (LCD /Polarizer backlight black/white line, scratching, stain)  W: width, L : length N : Count	<table border="1"> <thead> <tr> <th rowspan="2">Width(mm)</th> <th rowspan="2">Length(m)</th> <th colspan="3">Acceptable Qty</th> </tr> <tr> <th>A</th> <th>B</th> <th>C</th> </tr> </thead> <tbody> <tr> <td>$\Phi \leq 0.05$</td> <td>Ignore</td> <td colspan="2">Ignore</td> <td rowspan="3">Ignore</td> </tr> <tr> <td>$0.05 < W \leq 0.06$</td> <td>$L \leq 5.0$</td> <td colspan="2">$N \leq 3$</td> </tr> <tr> <td>$0.06 < W \leq 0.08$</td> <td>$L \leq 4.0$</td> <td colspan="2">$N \leq 2$</td> </tr> <tr> <td>$W > 0.08$</td> <td colspan="4">Define as spot defect</td> </tr> </tbody> </table>	Width(mm)	Length(m)	Acceptable Qty			A	B	C	$\Phi \leq 0.05$	Ignore	Ignore		Ignore	$0.05 < W \leq 0.06$	$L \leq 5.0$	$N \leq 3$		$0.06 < W \leq 0.08$	$L \leq 4.0$	$N \leq 2$		$W > 0.08$	Define as spot defect			
		Width(mm)			Length(m)	Acceptable Qty																						
			A	B		C																						
		$\Phi \leq 0.05$	Ignore	Ignore		Ignore																						
		$0.05 < W \leq 0.06$	$L \leq 5.0$	$N \leq 3$																								
$0.06 < W \leq 0.08$	$L \leq 4.0$	$N \leq 2$																										
$W > 0.08$	Define as spot defect																											
5.0	Electronic Components SMT.	Not allow missing parts, solderless connection, cold solder joint, mismatch, The positive and negative polarity opposite																										
6.0	Display color & Brightness.	1. Color: Measuring the color coordinates, The measurement standard according to the datasheet or samples. 2. Brightness: Measuring the brightness of White screen, The measurement standard according to the datasheet or Samples.																										
7.0	LCD Mura/Waving/Hot spot	Not visible through 5% ND filter in 50% gray or judge by limit sample if necessary.																										

8.0	CTP Related	CTP Cover sensor accidented black/white spot	<table border="1"> <thead> <tr> <th rowspan="2">Size Φ(mm)</th> <th colspan="3">Acceptable Qty</th> </tr> <tr> <th>A</th> <th>B</th> <th>C</th> </tr> </thead> <tbody> <tr> <td>$\Phi \leq 0.15$</td> <td colspan="2">Ignore</td> <td rowspan="3">Ignore</td> </tr> <tr> <td>$0.15 < \Phi \leq 0.25$</td> <td colspan="2">4 (distance ≥ 10mm)</td> </tr> <tr> <td>$0.25 < \Phi \leq 0.35$</td> <td colspan="2">3 (distance ≥ 10mm)</td> </tr> <tr> <td>$\Phi > 0.35$</td> <td colspan="3">0</td> </tr> </tbody> </table>	Size Φ (mm)	Acceptable Qty			A	B	C	$\Phi \leq 0.15$	Ignore		Ignore	$0.15 < \Phi \leq 0.25$	4 (distance ≥ 10 mm)		$0.25 < \Phi \leq 0.35$	3 (distance ≥ 10 mm)		$\Phi > 0.35$	0		
			Size Φ (mm)		Acceptable Qty																			
				A	B	C																		
			$\Phi \leq 0.15$	Ignore		Ignore																		
			$0.15 < \Phi \leq 0.25$	4 (distance ≥ 10 mm)																				
$0.25 < \Phi \leq 0.35$	3 (distance ≥ 10 mm)																							
$\Phi > 0.35$	0																							

		CTP Cover	<table border="1"> <thead> <tr> <th rowspan="2">Width(mm)</th> <th rowspan="2">Ignore (mm)</th> <th colspan="3">Acceptable Qty</th> </tr> <tr> <th>A</th> <th>B</th> <th>C</th> </tr> </thead> <tbody> <tr> <td>$\Phi \leq 0.05$</td> <td>Ignore</td> <td colspan="3">Ignore</td> </tr> <tr> <td>$0.05 < W \leq 0.06$</td> <td>$L \leq 4.0$</td> <td colspan="3">$N \leq 3$</td> </tr> <tr> <td>$0.06 < W \leq 0.08$</td> <td>$L \leq 3.0$</td> <td colspan="3">$N \leq 2$</td> </tr> <tr> <td>$0.08 < W$</td> <td colspan="3">Define as spot defect</td> </tr> </tbody> </table>	Width(mm)	Ignore (mm)	Acceptable Qty			A	B	C	$\Phi \leq 0.05$	Ignore	Ignore			$0.05 < W \leq 0.06$	$L \leq 4.0$	$N \leq 3$			$0.06 < W \leq 0.08$	$L \leq 3.0$	$N \leq 2$			$0.08 < W$	Define as spot defect		
Width(mm)	Ignore (mm)	Acceptable Qty																												
		A	B	C																										
$\Phi \leq 0.05$	Ignore	Ignore																												
$0.05 < W \leq 0.06$	$L \leq 4.0$	$N \leq 3$																												
$0.06 < W \leq 0.08$	$L \leq 3.0$	$N \leq 2$																												
$0.08 < W$	Define as spot defect																													
		CTP Cover Pinhole/ Lack of ink	<table border="1"> <thead> <tr> <th>Zone Size (mm)</th> <th>Acceptable Qty</th> </tr> </thead> <tbody> <tr> <td>$\Phi \leq 0.2$</td> <td>Ignore</td> </tr> <tr> <td>$0.2 < \Phi \leq 0.3$</td> <td>4(distance ≥ 10mm)</td> </tr> <tr> <td>$0.3 < \Phi \leq 0.4$</td> <td>2(distance ≥ 10mm)</td> </tr> <tr> <td>$\Phi > 0.4$</td> <td>0</td> </tr> </tbody> </table>	Zone Size (mm)	Acceptable Qty	$\Phi \leq 0.2$	Ignore	$0.2 < \Phi \leq 0.3$	4(distance ≥ 10 mm)	$0.3 < \Phi \leq 0.4$	2(distance ≥ 10 mm)	$\Phi > 0.4$	0																	
Zone Size (mm)	Acceptable Qty																													
$\Phi \leq 0.2$	Ignore																													
$0.2 < \Phi \leq 0.3$	4(distance ≥ 10 mm)																													
$0.3 < \Phi \leq 0.4$	2(distance ≥ 10 mm)																													
$\Phi > 0.4$	0																													
		CTP Bonding bubble/ accidented spot	<table border="1"> <thead> <tr> <th rowspan="2">Size Φ(mm)</th> <th colspan="2">Acceptable Qty</th> </tr> <tr> <th>A</th> <th>B</th> </tr> </thead> <tbody> <tr> <td>$\Phi \leq 0.1$</td> <td colspan="2">Ignore</td> </tr> <tr> <td>$0.1 < \Phi \leq 0.2$</td> <td colspan="2">3(distance ≥ 10mm)</td> </tr> <tr> <td>$0.2 < \Phi \leq 0.3$</td> <td colspan="2">2(distance ≥ 10mm)</td> </tr> <tr> <td>$\Phi > 0.3$</td> <td colspan="2">0</td> </tr> </tbody> </table>	Size Φ (mm)	Acceptable Qty		A	B	$\Phi \leq 0.1$	Ignore		$0.1 < \Phi \leq 0.2$	3(distance ≥ 10 mm)		$0.2 < \Phi \leq 0.3$	2(distance ≥ 10 mm)		$\Phi > 0.3$	0											
Size Φ (mm)	Acceptable Qty																													
	A	B																												
$\Phi \leq 0.1$	Ignore																													
$0.1 < \Phi \leq 0.2$	3(distance ≥ 10 mm)																													
$0.2 < \Phi \leq 0.3$	2(distance ≥ 10 mm)																													
$\Phi > 0.3$	0																													
		Assembly deflection	beyond the edge of backlight ≤ 0.2 mm																											
		CTP cover broken X : length Y : width Z : height	<table border="1"> <thead> <tr> <th>X</th> <th>Y</th> <th>Z</th> </tr> </thead> <tbody> <tr> <td>$X \leq 0.5$mm</td> <td>$Y \leq 0.5$mm</td> <td>$Z < \text{cover thickness}$</td> </tr> </tbody> </table> <p>* Circuitry broken is not allowed.</p>	X	Y	Z	$X \leq 0.5$ mm	$Y \leq 0.5$ mm	$Z < \text{cover thickness}$																					
X	Y	Z																												
$X \leq 0.5$ mm	$Y \leq 0.5$ mm	$Z < \text{cover thickness}$																												

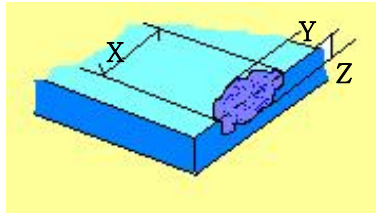
		CTP cover broken X : length Y : width Z : height	X	Y	Z	
			$X \leq 0.3\text{mm}$	$Y \leq 0.3\text{mm}$	Z < cover thickness s	
* Circuitry broken is not allowed.						

Criteria (functional items)

Number	Items	Criteria (mm)
1	No display	Not allowed
2	Missing segment	Not allowed
3	Short	Not allowed
4	Backlight no lighting	Not allowed
5	CTP no function	Not allowed

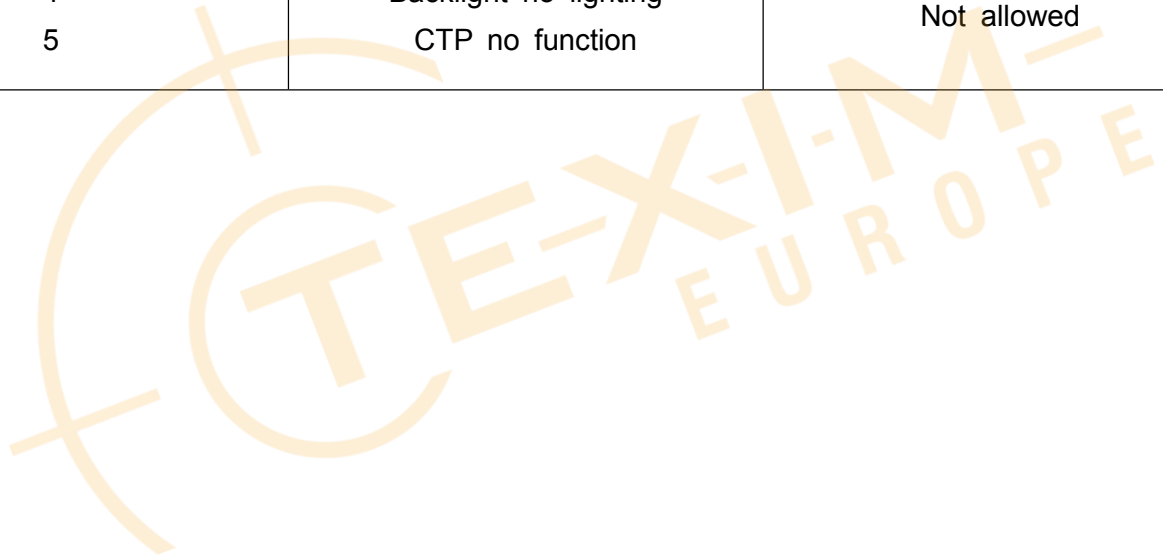

10. Reliability Test Result

Item	Condition	Inspection after test
High Temperature Operating	85°C,96H	Inspection after 2~4hours storage at room temperature, the sample shall be free from defects: 1.Air bubble in the LCD; 2.Non-display; 3.Missing segments/line; 4.Glass crack; 5.Current IDD is twice higher than initial value.
Low Temperature Operating	-30°C, 96HR	
High Temperature Storage	90°C, 96HR	
Low Temperature Storage	-40°C, 96HR	
High Temperature & High Humidity Operating	+60°C, 90% RH ,96 hours.	
Thermal Shock (Non-operation)	-10°C,30 min ↔ +60°C,30 min, Change time:5min 20CYC.	
ESD test	C=150pF, R=330,5points/panel Air:±8KV, 5times; Contact:±6KV, 5 times; (Environment: 15°C~35°C, 30%~60%).	
Vibration (Non-operation)	Frequency range:10~55Hz, Stroke:1.5mm Sweep:10Hz~55Hz~10Hz 2 hours for each direction of X.Y.Z. (6 hours for total) (Package condition).	
Box Drop Test	1 Corner 3 Edges 6 faces,80cm(MEDIUM BOX)	

Remark:

- 1.The test samples should be applied to only one test item.
- 2.Sample size for each test item is 5~10pcs.
- 3.For Damp Proof Test, Pure water(Resistance > 10MΩ) should be used.
- 4.In case of malfunction defect caused by ESD damage, if it would be recovered to normal state after resetting, it would be judged as a good part.
- 5.Failure Judgment Criterion: Basic Specification, Electrical Characteristic, Mechanical Characteristic, Optical Characteristic.
6. The color fading mura of polarizing filter should not care.

11. Cautions and Handling Precautions

11.1 Handling and Operating the Module

(1) When the module is assembled, it should be attached to the system firmly.

Do not warp or twist the module during assembly work.

(2) Protect the module from physical shock or any force. In addition to damage, this may cause improper operation or damage to the module and back-light unit.

(3) Note that polarizer is very fragile and could be easily damaged. Do not press or scratch the surface.

(4) Do not allow drops of water or chemicals to remain on the display surface.

If you have the droplets for a long time, staining and discoloration may occur.

(5) If the surface of the polarizer is dirty, clean it using some absorbent cotton or soft cloth.

(6) The desirable cleaners are water, IPA (Isopropyl Alcohol) or Hexane.

Do not use ketene type materials (ex. Acetone), Ethyl alcohol, Toluene, Ethyl acid or Methyl chloride. It might permanent damage to the polarizer due to chemical reaction.

(7) If the liquid crystal material leaks from the panel, it should be kept away from the eyes or mouth. In case of contact with hands, legs, or clothes, it must be washed away thoroughly with soap.

(8) Protect the module from static; it may cause damage to the CMOS ICs.

(9) Use finger-stalls with soft gloves in order to keep display clean during the incoming inspection and assembly process.

(10) Do not disassemble the module.

(11) Protection film for polarizer on the module shall be slowly peeled off just before use so that the electrostatic charge can be minimized.

(12) Pins of I/F connector shall not be touched directly with bare hands.

(13) Do not connect, disconnect the module in the "Power ON" condition.

(14) Power supply should always be turned on/off by the item 6.1 Power On Sequence & 6.2 Power Off Sequence

11.2 Storage and Transportation.

(1) Do not leave the panel in high temperature, and high humidity for a long time.

It is highly recommended to store the module with temperature from 0 to 35 °C and relative humidity of less than 70%

(2) Do not store the TFT-LCD module in direct sunlight.

(3) The module shall be stored in a dark place. When storing the modules for a long time, be sure to adopt effective measures for protecting the modules from strong ultraviolet radiation, sunlight, or fluorescent light.

(4) It is recommended that the modules should be stored under a condition where no condensation is allowed. Formation of dewdrops may cause an abnormal operation or a failure of the module.

In particular, the greatest possible care should be taken to prevent any module from being operated where condensation has occurred inside.

(5) This panel has its circuitry FPC on the bottom side and should be handled carefully in order not to be stressed.



12. Packing

---TBD-----



Disclaimer

ALL PRODUCTS, PRODUCT SPECIFICATIONS AND DATA ARE SUBJECT TO CHANGE WITHOUT NOTICE TO IMPROVE RELIABILITY, FUNCTION OR DESIGN OR OTHERWISE.

Texim Europe B.V. its affiliates, agents, and employees, and all persons acting on its or their behalf (collectively, "Texim"), disclaim any and all liability for any errors, inaccuracies or incompleteness contained in any datasheet or in any other disclosure relating to any product.

Texim makes no warranty, representation or guarantee regarding the suitability of the products for any particular purpose or the continuing production of any product.

It is the customer's responsibility to validate that a particular product with the properties described in the product specification is suitable for use in a particular application.

Parameters provided in datasheets and / or specifications may vary in different applications and performance may vary over time.

All operating parameters, including typical parameters, must be validated for each customer application by the customer's technical experts.

Please contact us if you have any questions about the contents of the datasheet.

This may not be the latest version of the datasheet. Please check with us if a later version is available.

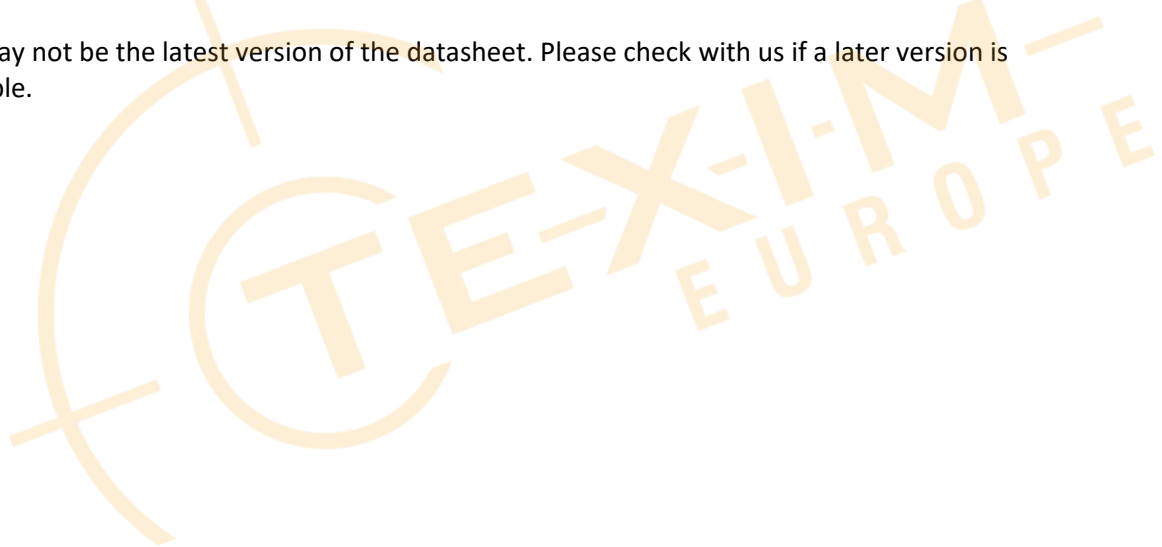



Headquarters & Warehouse

Elektrostraat 17
NL-7483 PG Haaksbergen
The Netherlands

T: +31 (0)53 573 33 33
E: info@texim-europe.com
Homepage: www.texim-europe.com



The Netherlands

Elektrostraat 17
NL-7483 PG Haaksbergen

T: +31 (0)53 573 33 33
E: nl@texim-europe.com



Belgium

Zuiderlaan 14, box 10
B-1731 Zellik

T: +32 (0)2 462 01 00
E: belgium@texim-europe.com



UK & Ireland

St Mary's House, Church Lane
Carlton Le Moorland
Lincoln LN5 9HS

T: +44 (0)1522 789 555
E: uk@texim-europe.com



Germany - North

Bahnhofstrasse 92
D-25451 Quickborn

T: +49 (0)4106 627 07-0
E: germany@texim-europe.com



Germany - South

Martin-Kollar-Strasse 9
D-81829 München

T: +49 (0)89 436 086-0
E: muenchen@texim-europe.com



Austria

Warwitzstrasse 9
A-5020 Salzburg

T: +43 (0)662 216 026
E: austria@texim-europe.com



Nordic

Søndre Jagtvej 12
DK-2970 Hørsholm

T: +45 88 20 26 30
E: nordic@texim-europe.com



Italy

Martin-Kollar-Strasse 9
D-81829 München

T: +49 (0)89 436 086-0
E: italy@texim-europe.com