



深圳市一众显示科技有限公司

SHEN ZHEN TEAM SOURCE DISPLAY TECH. CO, LTD.

# TFT-LCD Module Specification

Distributed by:



**Module NO.:** TST050WVHS-36C

**Version:** V1.1

APPROVAL FOR SPECIFICATION

APPROVAL FOR SAMPLE

For Customer' s Acceptance:	
Approved by	Comment

Team Source Display:		
Presented by	Reviewed by	Approved by

Version No.	Date	Content	Remark
V1.0	2019-11-8	Initial Release	
V1.1	2021-6-9	Change ctp diver ic to FT5446	

**CONTENTS**

<b>1 GENERAL CHARACTERISTICS.....</b>	<b>- 3 -</b>
<b>2 PRODUCT DRAWINGS.....</b>	<b>- 4 -</b>
<b>3 INTERFACE DESCRIPTION.....</b>	<b>- 5 -</b>
3.1 LCM INTERFACE DESCRIPTION.....	- 5 -
3.2 CTP INTERFACE DESCRIPTION.....	- 6 -
<b>4 TIMING CHARACTERISTICS.....</b>	<b>- 7 -</b>
4.1 SYNC MODE.....	- 7 -
4.2 SYNC-DE MODE.....	- 8 -
4.3 DE MODE.....	- 9 -
4.4 PARALLEL 24-BIT RGB INPUT TIMING TABLE.....	- 10 -
<b>5 ABSOLUTE MAXIMUM RATINGS.....</b>	<b>- 10 -</b>
<b>6 ELECTRICAL CHARACTERISTICS.....</b>	<b>- 10 -</b>
<b>7 BACKLIGHT CHARACTERISTICS.....</b>	<b>- 10 -</b>
<b>8 LCD OPTICAL SPECIFICATIONS.....</b>	<b>- 11 -</b>
<b>9 CAPACITIVE TOUCH PANEL SPECIFICATIONS.....</b>	<b>- 13 -</b>
9.1 MECHANICAL CHARACTERISTICS.....	- 13 -
9.2 ELECTRICAL CHARACTERISTICS.....	- 13 -
9.3 INTERFACE TIMING CHARACTERISTICS.....	- 13 -
<b>10 RELIABILITY TEST.....</b>	<b>- 14 -</b>
10.1 ABOUT IMAGE STICKING.....	- 14 -
10.1.1 <i>What is Image Sticking?</i> .....	- 14 -
10.1.2 <i>What causes Image Sticking?</i> .....	- 15 -
10.1.3 <i>How to Avoid Image Sticking?</i> .....	- 15 -
10.1.4 <i>How to Fix the Image Sticking?</i> .....	- 15 -
10.1.5 <i>Is Image Sticking Covered by TSD RMA Warranty?</i> .....	- 16 -
10.2 OTHERS.....	- 16 -
<b>11 SUGGESTIONS FOR USING LCD MODULES.....</b>	<b>- 16 -</b>
11.1 HANDLING OF LCM.....	- 16 -
11.2 STORAGE.....	- 17 -
<b>12 LIMITED WARRANTY.....</b>	<b>- 17 -</b>

## 1 General Characteristics

ITEM	Specification	Unit
LCD Type	a-Si TFT, Transmissive, Normally Black, IPS	-
LCD Size	5.0	inch
Resolution (W x H)	800x (RGB) ×480	pixel
LCM outline	140.7(H) x 93.83(V) x 4.63(D)	mm
Active Area	108.00 (H) x 64.80 (V)	mm
Pixel Pitch	0.135(H)x 0.135(V)	mm
Viewing Direction	ALL o'clock	-
Color Depth	16.7M	-
Pixel Arrangement	RGB-stripe	-
Backlight Type	18 LEDs, 60mA	-
Surface Treatment	Clear	-
Interface Type	RGB-24bit	-
Input Voltage	3.3	V
With/Without TP	With CTP(FT5446)	-
Weight	TBD	g

**Note 1: RoHS compliant**

**Note 2: LCM weight tolerance: ± 5%.**

## 2 Product drawings

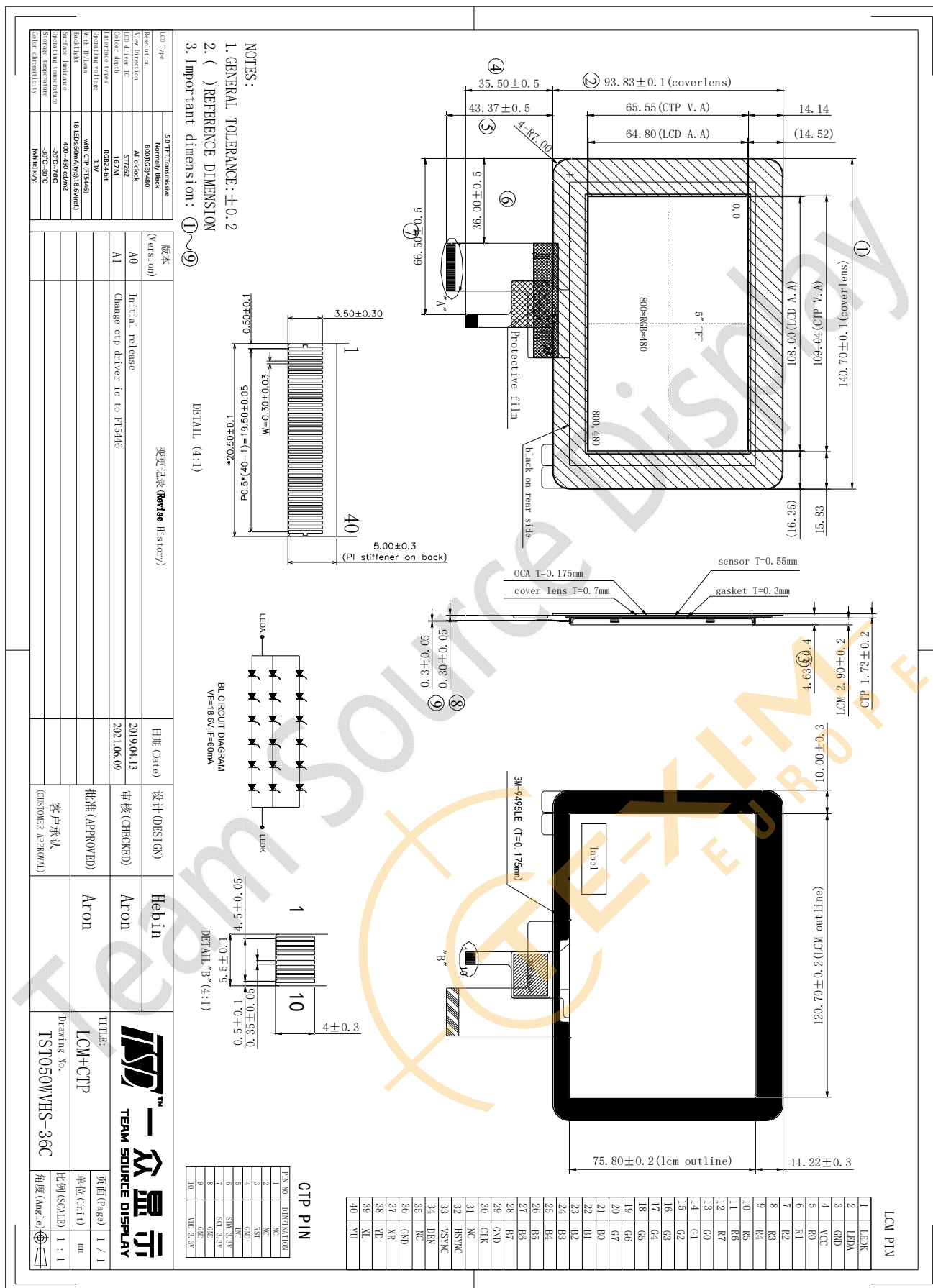

### 3 Interface description

#### 3.1 LCM interface description

PIN NO.	Symbol	description
1	LEDK	Backlight K Cathode input pin.
2	LEDA	Backlight A Anode input pin.
3	GND	System Ground. (0V)
4	VCC	Power supply +3.3V
5~12	R0~R7	Red Data BUS
13~20	G0~G7	Green Data BUS
21~28	B0~B7	Blue Data BUS
29	GND	System Ground. (0V)
30	CLK	Clock for input data. Data latched at rising/falling edge of this signal. Default is falling edge.
31	NC	
32	HSYNC	Horizontal sync input in digital parallel RGB. Negative polarity.
33	VSYNC	Vertical sync input in digital parallel RGB. Negative polarity.
34	DEN	Input data enable control. When DE mode, active High to enable data input. (Normally pull low)
35	NC	Not connection
36	GND	System Ground. (0V)
37	XR/X+	Not connection
38	YD/Y-	Not connection
39	XL/X-	Not connection
40	YU/Y+	Not connection

### 3.2 CTP interface description

PIN NO.	Symbol	description
1	NC	NO connect
2	NC	NO connect
3	RST	External Reset, Low is active
4	GND	Ground. (0V)
5	INT	Interrupt request to the host
6	SDA	I2C data input and output
7	SCL	I2C clock input
8	GND	Ground. (0V)
9	GND	Ground. (0V)
10	VDD	Power supply +3.3V

## 4 Timing Characteristics

### 4.1 SYNC Mode

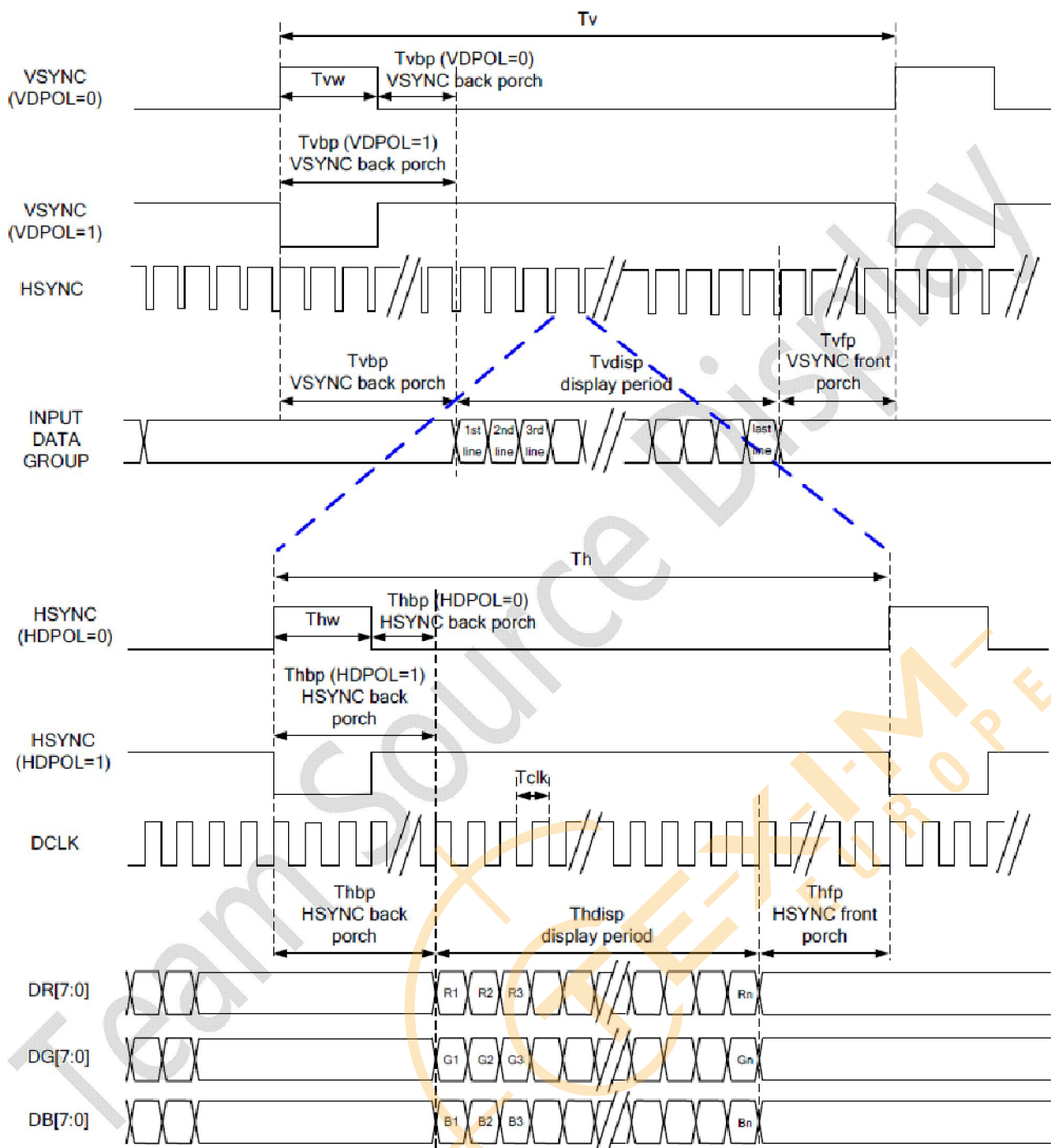

## 4.2 SYNC-DE Mode

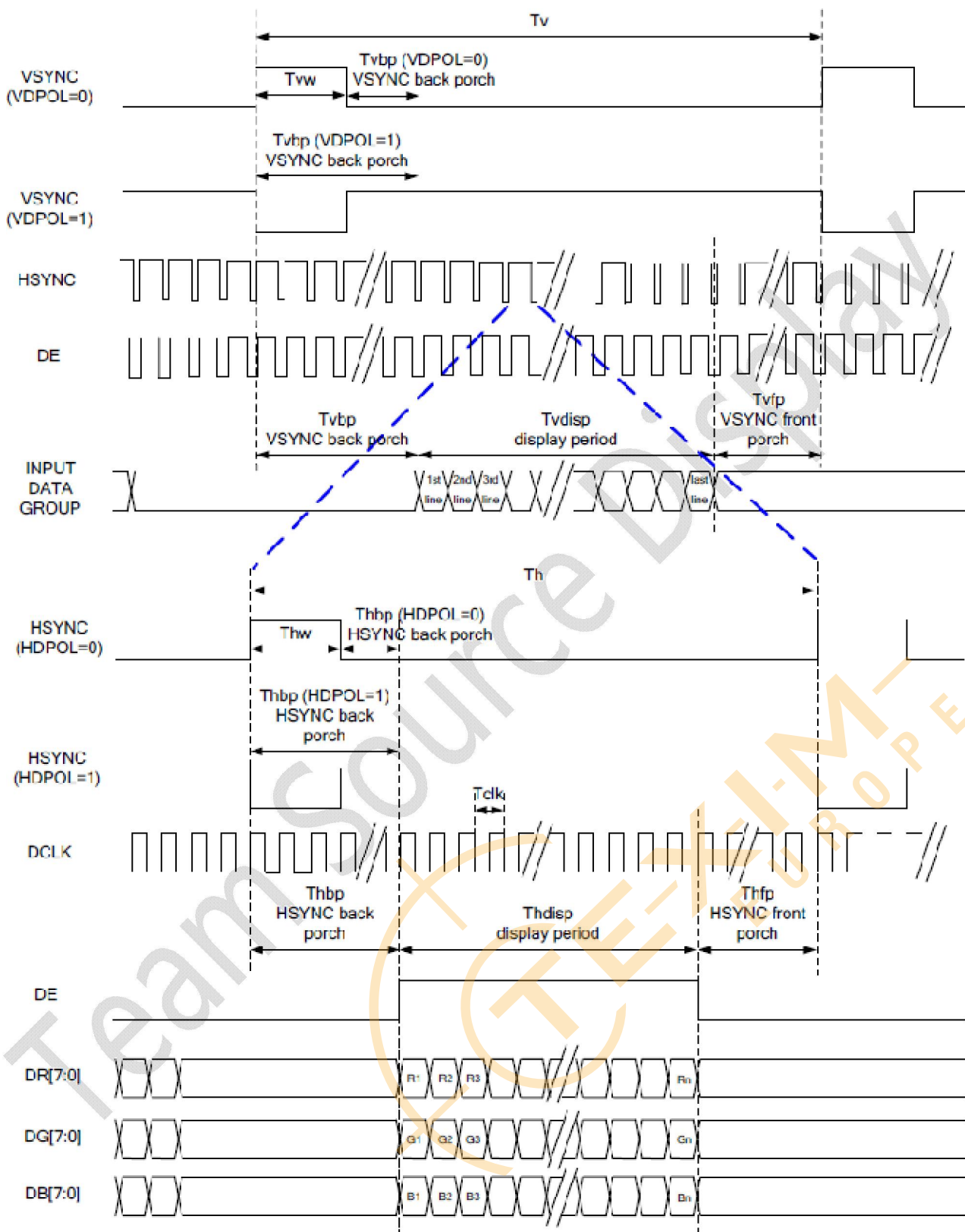



### 4.3 DE Mode

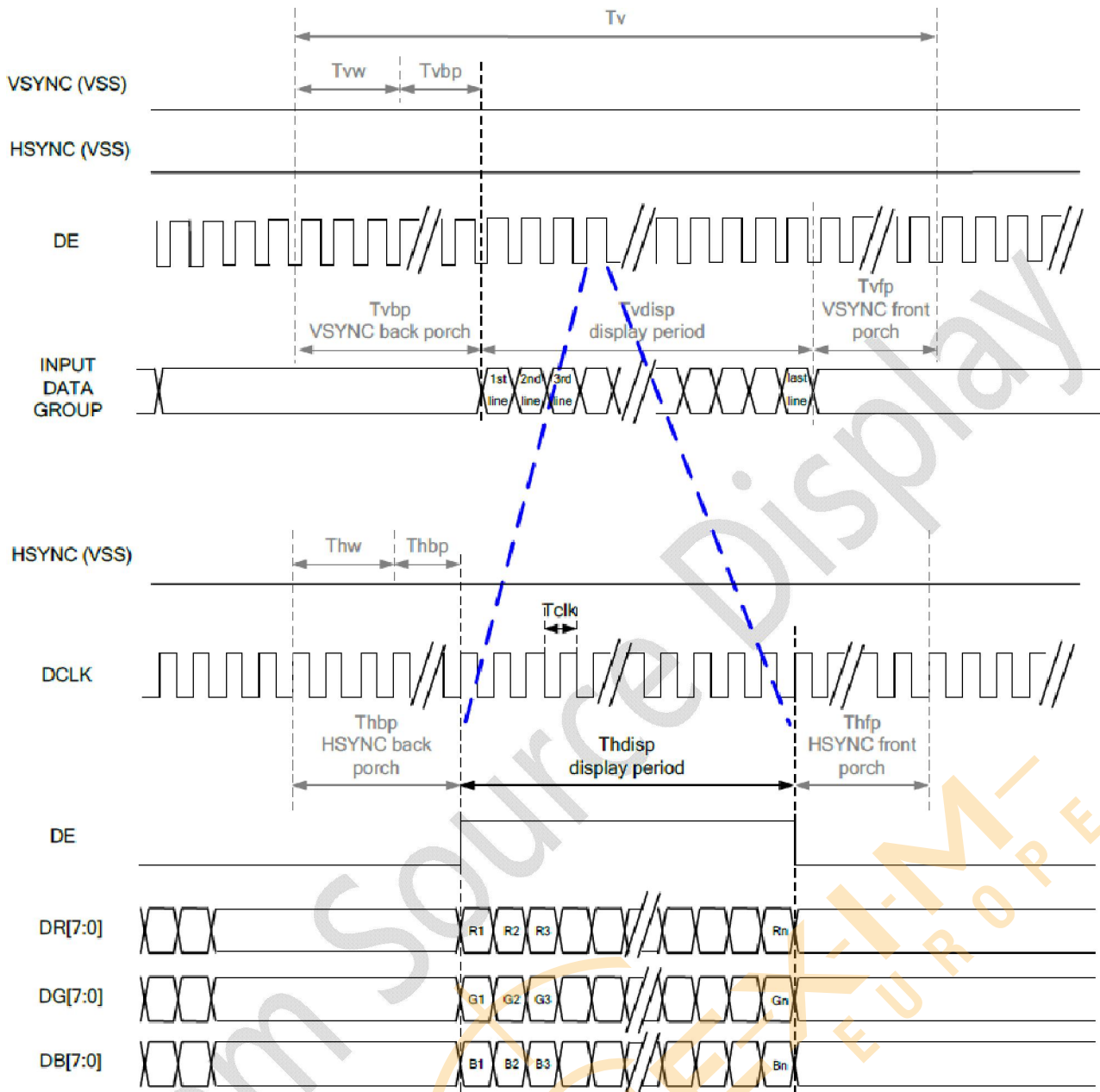

## 4.4 Parallel 24-bit RGB Input Timing Table

Parallel 24-bit RGB Input Timing (PVDD=VDD=VDDI= 3.3V, AGND= 0V, TA=25°C)

Parallel 24-bit RGB Interface Timing Table							
Item	Symbol	Min.	Typ.	Max.	Unit	Remark	
DCLK Frequency	Fclk	23	25	27	MHz		
HSYNC	Period Time	Th	808	816	896	DCLK	
	Display Period	Thdisp	800			DCLK	
	Back Porch	Thbp	4	8	48	DCLK	
	Front Porch	Thfp	4	8	48	DCLK	
	Pulse Width	Thw	2	4	8	DCLK	
VSYNC	Period Time	Tv	488	496	504	HSYNC	
	Display Period	Tvdisp	480			HSYNC	
	Back Porch	Tvbp	4	8	12	HSYNC	
	Front Porch	Tvfp	4	8	12	HSYNC	
	Pulse Width	Tvw	2	4	8	HSYNC	

## 5 Absolute Maximum Ratings

PARAMETER	SYMBOL	MIN	MAX	UNIT
Supply Voltage (Analog)	VDD~GND	-0.3	4.0	V
Logic signal voltage(I/O)	IOVDD~GND	-0.3	4.0	V
Operating Temperature	TOP	-20	70	° C
Storage Temperature	TST	-30	80	° C
Storage Humidity	RH	-	90%(Max 60° C)	RH

## 6 Electrical Characteristics

PARAMETER	SYMBOL	MIN	TYP	MAX	UNIT
Analog operating voltage	VDD	3.0	3.3	3.6	V
Logic operating voltage	VDDI	3.0	3.3	VDD	
Input Voltage ' H ' level	VIH	0.7VDDI	-	VDDI	
Input Voltage ' L ' level	VIL	GND	-	0.3VDDI	
Output Voltage ' H ' level	VOH	VDDI-0.4	-	VDDI	
Output Voltage ' L ' level	VOL	GND	-	GND+0.4	

## 7 Backlight Characteristics

ITEM	SYMBOL	MIN	TYP	MAX	UNIT
Voltage for LED backlight	V <sub>f</sub>	-	18.6	-	V
Current for LED backlight	I <sub>f</sub>	-	60	-	mA
Power consumption	W <sub>bl</sub>	-	1152	-	mW
Uniformity	Avg	80	-	-	%
LED Life Time	-	30000	40000	-	Hrs

Note:

- 1.The LED life time is defined as the module brightness decrease to 50% original brightness at Ta=25°C, 60%RH ±5 %.
2. The life time of LED will be reduced if LED is driven by high current, high ambient temperature and humidity conditions.
3. Typical operating life time is an estimated data.
4. Permanent damage to the device may occur if maximum values are exceeded or reverse voltage is loaded .Functional operation should be restricted to the conditions described under normal operating conditions.

## 8 LCD Optical specifications

Item	Symbol	Condition	Specification			Unit	Remark
			Min	Typ	Max		
Response time (By Quick)	Tr+Tf	-	-	30	40	ms	Note 2
Contrast ratio	CR	-	-	800	-	-	Note 3
Surface luminance	Lv	$\theta=0^\circ$	400	450	-	cd/m <sup>2</sup>	Note 4
Luminance uniformity	Yu	$\theta=0^\circ$	80	-	-	%	Note 6
NTSC	-	$\theta=0^\circ$	45	50	-	%	Note 6
Viewing angle	Top	CR $\geq 10$	70	80	-	Deg.	Note 7
	Bottom	CR $\geq 10$	70	80	-		
	Left	CR $\geq 10$	70	80	-		
	Right	CR $\geq 10$	70	80	-		
CIE(x,y) chromaticity	Wx	$\theta=0^\circ$	Typ -0.03	0.320	Typ +0.03		Note 5
	Wy			0.345			
	Rx			0.629			
	Ry			0.326			
	Gx			0.337			
	Gy			0.546			
	Bx			0.136			
	By			0.143			

Note 1: Ambient temperature = 25°C.

Note 2: Definition of response time:

The output signals of TRD-100 are measured when the input signals are changed to "White" (falling time) and from "White" to "Black" (rising time), respectively. The interval is between the 10% and 90% of amplitudes. Refer to figure as below.

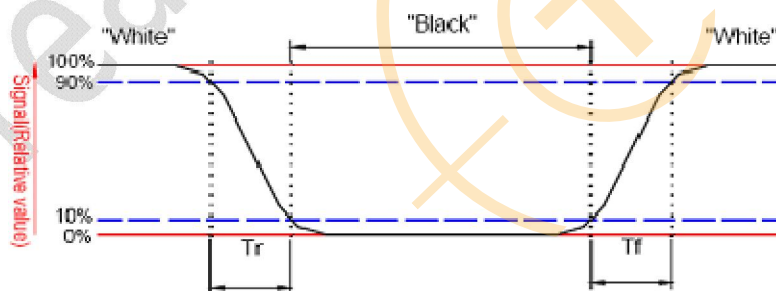

Note 3: Definition of contrast ratio:

Contrast ratio is calculated by the following formula.

$$\text{Contrast ratio (CR)} = \frac{\text{Brightness on the "white" state}}{\text{Brightness on the "black" state}}$$

Measured at the center area of the LCD.

Note 4:Definition of surface luminance

Surface luminance is the luminance with all pixels displaying white

Note 5: For contrast ratio, Surface Luminance, Luminance uniformity and CIE,the testing data is base on TOPCON' s BM-7 photo detector or compatible.

Size :  $S \leq 4.3''$  (see Figure A B)

H,V : Active area

Light spot size=7.7mm (BM-7)50cm distance or compatible distance from the LCD surface to detector lens.

test spot position : see Figure B.

measurement instrument : TOPCON' s luminance meter BM-7 or compatible.

Size :  $4.3 < S \leq 12.3''$  (see Figure A C)

H,V : Active area

Light spot size=7.7mm (BM-7)50cm distance or compatible distance from the LCD surface to detector lens.

test spot position : see Figure C.

measurement instrument : TOPCON' s luminance meter BM-7 or compatible.

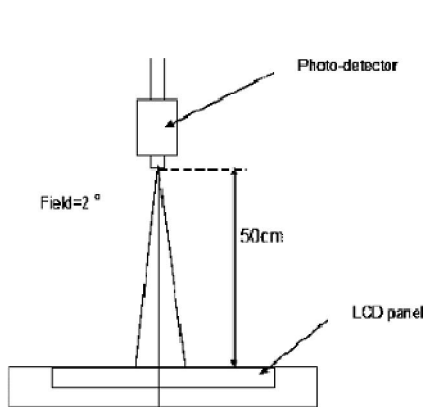

Figure A

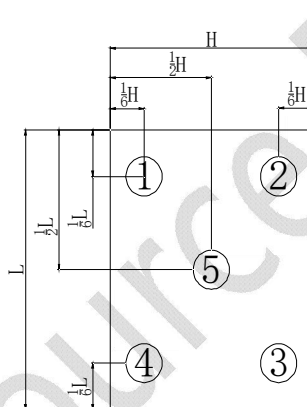

Figure B

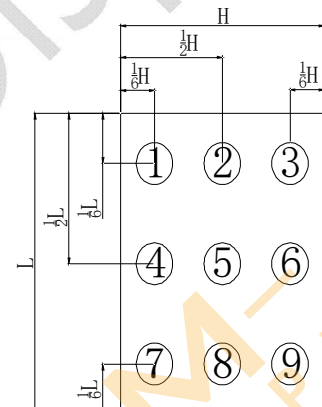

Figure C

Note 6:Definition of Luminance Uniformity

Active area is divided into 5 or 9 measuring areas,Every measuring point is placed at the center of each measuring area

Bmax: The measured maximum luminance of all measurement position.

Bmin: The measured minimum luminance of all measurement position.

**Luminance Uniformity (Yu)=(Bmin/Bmax)x100%**

Note 7: Definition of viewing angle

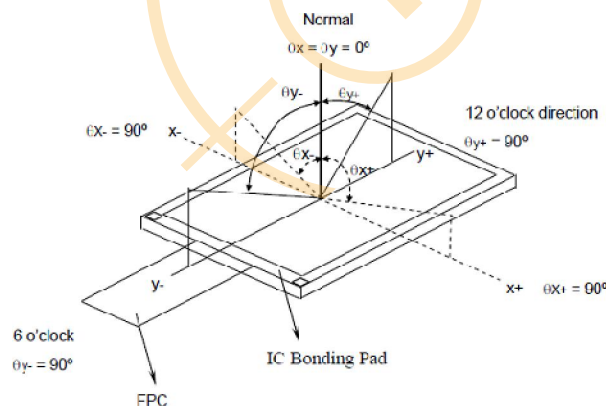

## 9 Capacitive Touch Panel specifications

### 9.1 Mechanical characteristics

DESCRIPTION	INL SPECIFICATION	REMARK
Touch Panel Size	5.0	
Outline Dimension (OD)	140.70(H) x 93.83(V) mm	Cover Lens Outline
Product Thickness	1.73mm	With FPC and frame D.S.T
Glass Thickness	0.7mm	
View Area	108.0x64.8mm	
Input Method	5 Fingers	
Activation Force	Touch	
Surface Hardness	≥6H	

### 9.2 Electrical characteristics

DESCRIPTION	SPECIFICATION	
Operating Voltage	DC 2.8~3.3V	
Power Consumption (IDD)	Active Mode	2.8-3.3mA
	Sleep Mode	50-100uA
Interface	I <sup>2</sup> C	
Controller IC	FT5446	
I <sup>2</sup> C address	0x70	
Resolution	800*480	

### 9.3 Interface timing characteristics

PARAMETER	MIN	MAX	UNIT
SCL Frequency	-	400K	Hz
Bus Free Time Between a STOP and START Condition	4.7	-	uS
Hold Time (repeated) START Condition	4.0	-	uS
Data Setup Time	250	-	nS
Setup Time for Repeated START Condition	4.7	-	uS
Setup Time for STOP Condition	4.0	-	uS

## 10 RELIABILITY TEST

NO.	TEST ITEM	TEST CONDITION	INSPECTION AFTER TEST
1	High Temperature Storage	80±2°C/96 hours	Inspection after 2~4 hours storage at room temperature and humidity. The condensation is not accepted. The sample shall be free from defects:  1. Air bubble in the LCD 2. Seal leak 3. Non-display 4. Missing segments 5. Glass crack
2	Low Temperature Storage	-30±2°C/96 hours	
3	High Temperature Operating	70±2°C/96 hours	
4	Low Temperature Operating	-20±2°C/96 hours	
5	Temperature Cycle	-30±2°C ~ 25~ 80± 2°C × 10 cycles (30 min.) (5min.) (30min.)	
6	Damp Proof Test	60°C ±5°C × 90%RH/96 hours	
7	Vibration Test	Frequency 10Hz~55Hz Stroke: 1.5mm Sweep: 10Hz~150 Hz~10Hz 2 hours For each direction of X, Y, Z	
8	Packing Drop Test	Height: 50 cm 1 corner, concrete floor	
9	Electrostatic Discharge Test	C=150pF, R=330 Ω Air: ±8KV 150pF/330Ω 30 times Contact: ±4KV,20 times	
10	Image Sticking	25°C,60%RH (ref.to Remark(1))/30 minutes	

**Remark (1):** Switch the image to Grey 127 after displaying the 5\*8 chess pattern for **30 minutes**, the afterimage disappears within 10 seconds.

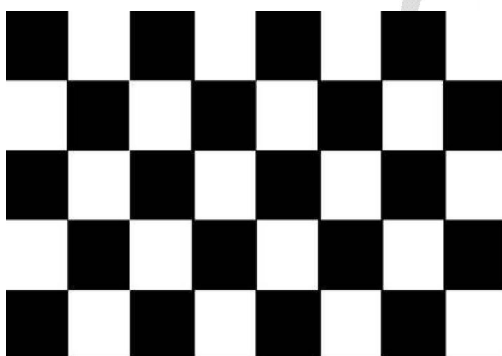

5\*8 chess pattern



Gray127

### 10.1 About Image Sticking

#### 10.1.1 What is Image Sticking?

If you remain a fixed image on LCD Display for a long period of time, you may experience a phenomenon called Image Sticking. Image Sticking - sometimes also called “image retention” or “ghosting” - is a phenomenon where a faint outline of a previously displayed image remains visible on the screen when the image is changed. It can occur at variable levels of intensity depending on the specific image makeup, as well as the amount of time the core image elements are allowed to remain unchanged on the screen. In POS applications, for example, a button menu which remains fixed, or in

which the “frame” elements (core image) remain fixed and the buttons may change, may be susceptible to image sticking. It is important to note that if the screen is used exclusively for this application, the user may never notice this phenomenon since the screen never displays other content. It is only when an image other than the “retained” image is shown on the screen that this issue becomes evident. Image sticking is different that the “burn-in” effect commonly associated with phosphor based devices.

### 10.1.2 What causes Image Sticking?

Image sticking is an intrinsic behavior of LCD displays due to the susceptibility to polarization of the interior materials (liquid crystals) when used under static, charged conditions (continuously displaying the same image). The individual liquid crystals in an LCD panel have unique electrical properties. Displaying a fixed pattern - such as the POS menu described above - over prolonged periods can cause a parasitic charge build-up (polarization) within the liquid crystals which affects the crystals’ optical properties and ultimately prevents the liquid crystal from returning to its normal, relaxed state when the pattern is finally changed. This effect takes place at a cellular level within the LCD, and the effect can cause charged crystal alignment at the bottom or top of a crystal cell in the “z” axis, or even crystal migration to the edges of a cell, again based on their polarity. These conditions can cause image sticking over an entire area, or at boundaries of distinct color change respectively. In either case, when the liquid crystals in the pixels and sub-pixels utilized to display the static image are polarized such that they can not return fully to their “relaxed” state upon deactivation, the result is a faint, visible, retained image on the panel upon presentation of a new, different image. The actual rate of image retention depends on variation factors such as the specific image, how long it is displayed unchanged, the temperature within the panel and even the specific panel brand due to manufacturing differences amongst panel manufacturers.

### 10.1.3 How to Avoid Image Sticking?

- Try not to operate the LCD with a “fixed” image on the screen for more than 1 hours.
- If you are operating the monitor in an elevated temperature environment and with a displayed image which is contrary to the recommendations in “For Software Developers” below, image stick can occur in as little as 30 minutes. Adjust your screen saver settings accordingly.
- Power down the unit during prolonged periods of inactivity such as the hours a store is closed or a shift during which the piece of equipment isn’t used.
- Use a screensaver with a black or medium gray background that is automatically set to come on if the device is inactive for more than 5-10 minutes.
- Avoid placing the monitor in poorly ventilated areas or in areas that will create excess heat around the monitor for software developers.
- In defining the icons, buttons, or windows in the screen, try to utilize block patterns instead of distinct lines as borders for dividing the display into distinct areas.
- If it is necessary to display a static image, try to use colors that are symmetric to the middle grey level at the boundary of two different colors, and slightly shift the borders line once in a while.
- Try to utilize medium gray hues for those areas that will have prolonged display times or remain static as other menu elements change.

### 10.1.4 How to Fix the Image Sticking?

Unlike the usually irreversible “burn-in” effects commonly associated with direct view phosphor display devices such as CRTs, an image retained on an LCD display can be reversed - often to a point of total invisibility. However, the severity of the underlying causes (as described above) of the image retained on a specific display, as

well as the variation factors (see “For Software Developers” above) under which the retained image was created, will dictate the final level of retention reversal. One way to erase a retained image on a panel is to run the screen (monitor “on”) in an “all black” pattern for 4-6 hours. It is also helpful to do this in an elevated temperature environment of approximately 35° to 50° C. Again, utilizing a dynamic screen saver with an all black background during prolonged idle display periods is a good way to avoid image retention issues.

### 10.1.5 Is Image Sticking Covered by TSD RMA Warranty?

Image sticking is a phenomenon inherent to LCD Display technology itself, and as such, the occurrence of this “ghosting” effect is considered normal operation by the manufacturers of the LCD display modules which are integrated into today’s monitor solutions. TSD does not warrant any display against the occurrence of image sticking. We strongly advise that you follow the operating recommendations listed above to avoid the occurrence of this phenomenon.

### 10.2 Others

1. Issues that are not defined in this document shall be discussed and agreed with both parties. (Customer and supplier)
2. Unless otherwise agreed upon in writing, the criteria shall be applied to both parties. (Customer and supplier)

## 11 Suggestions for using LCD modules

### 11.1 Handling of LCM

1. The LCD screen is made of glass. Don't give excessive external shock, or drop from a high place.
2. If the LCD screen is damaged and the liquid crystal leaks out, do not lick and swallow. When the liquid is attach to your hand, skin, cloth etc, wash it off by using soap and water thoroughly and immediately.
3. Don't apply excessive force on the surface of the LCM.
4. If the surface is contaminated, clean it with soft cloth. If the LCM is severely contaminated, use Isopropyl alcohol/Ethyl alcohol to clean. Other solvents may damage the polarizer. The following solvents is especially prohibited: water , ketone Aromatic solvents etc.
5. Exercise care to minimize corrosion of the electrode. Corrosion of the electrodes is accelerated by water droplets, moisture condensation or a current flow in a high-humidity environment.
6. Install the LCD Module by using the mounting holes. When mounting the LCD module make sure it is free of twisting, warping and distortion. In particular, do not forcibly pull or bend the I/O cable or the backlight cable.
7. Don't disassemble the LCM.
8. To prevent destruction of the elements by static electricity, be careful to maintain an optimum work environment.
  - Be sure to ground the body when handling the LCD modules.
  - Tools required for assembling, such as soldering irons, must be properly grounded.
  - To reduce the amount of static electricity generated, do not conduct assembling and other work under dry conditions.
  - The LCD module is coated with a film to protect the display surface. Exercise care when peeling off this protective film since static electricity may be generated.
9. Do not alter, modify or change the the shape of the tab on the metal frame.
10. Do not make extra holes on the printed circuit board, modify its shape or change the positions of components to be attached.
11. Do not damage or modify the pattern writing on the printed circuit board.
12. Absolutely do not modify the zebra rubber strip (conductive rubber) or heat seal connector



13. Except for soldering the interface, do not make any alterations or modifications with a soldering iron.
14. Do not drop, bend or twist LCM.

## 11.2 Storage

1. Store in an ambient temperature of 5 to 45 °C, and in a relative humidity of 40% to 60%. Don't expose to sunlight or fluorescent light.
2. Storage in a clean environment, free from dust, active gas, and solvent.
3. Store in antistatic container.

## 12 Limited Warranty

1. Our warranty liability is limited to repair and/or replacement. We will not be responsible for any consequential loss.
2. If possible, we suggest customer to use up all LCD modules as soon as possible. If the LCD module storage time over twelve months, we suggest to recheck it before being used.
3. Any product issues must be feedback to TSD within 12 months since delivery, otherwise, we will not be responsible for the subsequent or consequential events.

## **Disclaimer**

ALL PRODUCTS, PRODUCT SPECIFICATIONS AND DATA ARE SUBJECT TO CHANGE WITHOUT NOTICE TO IMPROVE RELIABILITY, FUNCTION OR DESIGN OR OTHERWISE.

Texim Europe B.V. its affiliates, agents, and employees, and all persons acting on its or their behalf (collectively, "Texim"), disclaim any and all liability for any errors, inaccuracies or incompleteness contained in any datasheet or in any other disclosure relating to any product.

Texim makes no warranty, representation or guarantee regarding the suitability of the products for any particular purpose or the continuing production of any product.

It is the customer's responsibility to validate that a particular product with the properties described in the product specification is suitable for use in a particular application.

Parameters provided in datasheets and / or specifications may vary in different applications and performance may vary over time.

All operating parameters, including typical parameters, must be validated for each customer application by the customer's technical experts.

Please contact us if you have any questions about the contents of the datasheet.

This may not be the latest version of the datasheet. Please check with us if a later version is available.

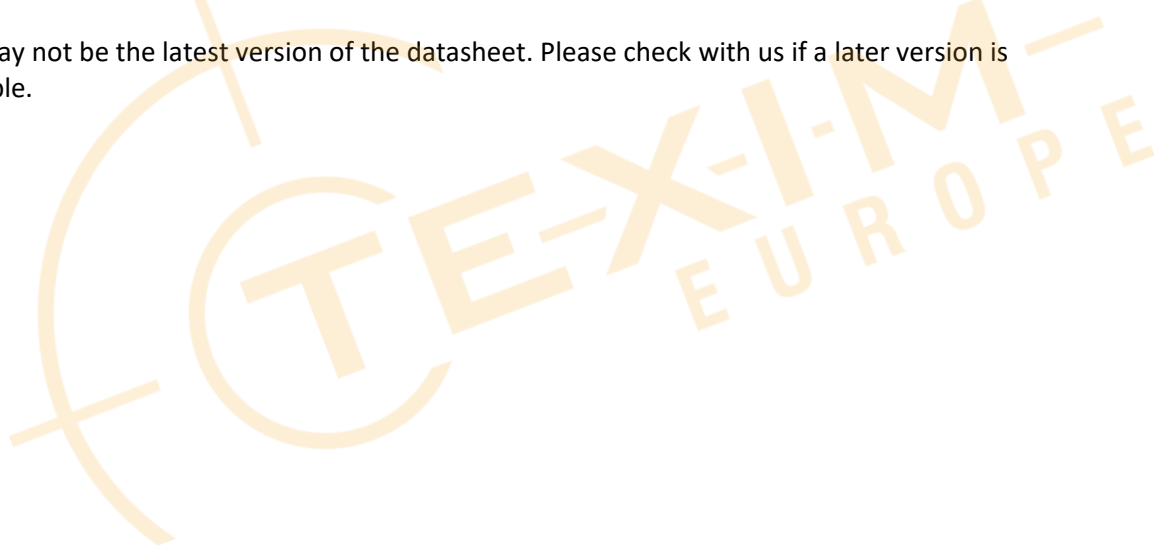



## Headquarters & Warehouse

Elektrostraat 17  
NL-7483 PG Haaksbergen  
The Netherlands

T: +31 (0)53 573 33 33  
E: info@texim-europe.com  
Homepage: www.texim-europe.com



### The Netherlands

Elektrostraat 17  
NL-7483 PG Haaksbergen

T: +31 (0)53 573 33 33  
E: nl@texim-europe.com



### Belgium

Zuiderlaan 14, box 10  
B-1731 Zellik

T: +32 (0)2 462 01 00  
E: belgium@texim-europe.com



### UK & Ireland

St Mary's House, Church Lane  
Carlton Le Moorland  
Lincoln LN5 9HS

T: +44 (0)1522 789 555  
E: uk@texim-europe.com



### Germany - North

Bahnhofstrasse 92  
D-25451 Quickborn

T: +49 (0)4106 627 07-0  
E: germany@texim-europe.com



### Germany - South

Martin-Kollar-Strasse 9  
D-81829 München

T: +49 (0)89 436 086-0  
E: muenchen@texim-europe.com



### Austria

Warwitzstrasse 9  
A-5020 Salzburg

T: +43 (0)662 216 026  
E: austria@texim-europe.com



### Nordic

Søndre Jagtvej 12  
DK-2970 Hørsholm

T: +45 88 20 26 30  
E: nordic@texim-europe.com



### Italy

Martin-Kollar-Strasse 9  
D-81829 München

T: +49 (0)89 436 086-0  
E: italy@texim-europe.com