

TFT-LCD Module Datasheet

ITEM NO.: TST24QV13AR

Version: V2.0

| ITEM | Specification | Unit |
|--------------------------------|--|-------------------|
| LCD Type | a-Si TFT, Transmissive, Normally white, TN | - |
| LCD Size | 2.4 | inch |
| Resolution (W x H) | 240 x (RGB) x 320 | pixel |
| LCM (W x H x D) | 42.72(W) x 60.26(H) x 3.5(D) | mm |
| Active Area (W x H) | 36.72 (W) x 48.96 (H) | mm |
| Dot Pitch (W x H) | 0.051 (W) x 0.153 (H) | mm |
| Viewing Direction | 12 o'clock | - |
| Gray Scale Inversion Direction | 6 o'clock | - |
| Viewing Angle | Top:55; Bottom:35 Left/ Right:55 | deg. |
| Color Depth | 65K/262K | - |
| Pixel Arrangement | RGB Vertical stripe | - |
| Backlight Type | 4 LEDs | - |
| Surface Luminance | 304 | cd/m ² |
| Surface Treatment | Anti-Glare | - |
| Driver IC | ILI9341V | - |
| Interface Type | MCU 8/16-bit | - |
| Input Voltage | 2.8 | V |
| With/Without TP | Resistive Touch Panel | - |
| Weight | 16.4 | g |

Note 1: RoHS compliant

Note 2: LCM weight tolerance: ± 5%.

| Version No. | Date | Content | Remark |
|-------------|------------|-----------------|--------|
| V1.0 | 2015-10-12 | Initial Release | |
| V2.0 | 2015-12-10 | Viewing Angle | |
| | | | |

CONTENTS

| | | |
|-----------|---|---------------|
| 1 | PRODUCT DRAWINGS | - 3 - |
| 2 | INTERFACE DESCRIPTION | - 4 - |
| 3 | LCM INTERFACE TIMING | - 5 - |
| 3.1 | RESET TIMING | - 5 - |
| 3.2 | MCU READ/WRITE TIMING | - 5 - |
| 4 | INITIAL CODE | - 6 - |
| 5 | ABSOLUTE MAXIMUM RATINGS | - 9 - |
| 6 | ELECTRICAL CHARACTERISTICS | - 9 - |
| 7 | BACKLIGHT CHARACTERISTICS | - 9 - |
| 8 | LCD OPTICAL SPECIFICATIONS | - 10 - |
| 9 | TOUCH PANEL SPECIFICATIONS | - 12 - |
| 10 | RELIABILITY TEST | - 12 - |
| 11 | INSPECTION STANDARDS | - 13 - |
| 11.1 | VISUAL INSPECTION CRITERION IN COSMETIC | - 13 - |
| 11.1.1 | <i>Glass defect</i> | - 13 - |
| 11.1.2 | <i>LCM appearance defect</i> | - 13 - |
| 11.1.3 | <i>FPC</i> | - 14 - |
| 11.1.4 | <i>Black tape</i> | - 14 - |
| 11.1.5 | <i>Silicon</i> | - 14 - |
| 11.1.6 | <i>Touch Panel</i> | - 14 - |
| 11.2 | VISUAL INSPECTION CRITERION IN ELECTRICAL DISPLAY | - 15 - |
| 11.3 | OTHERS | - 16 - |
| 12 | SUGGESTIONS FOR USING LCD MODULES | - 16 - |
| 12.1 | HANDLING OF LCM | - 16 - |
| 12.2 | STORAGE | - 17 - |

1 Product drawings

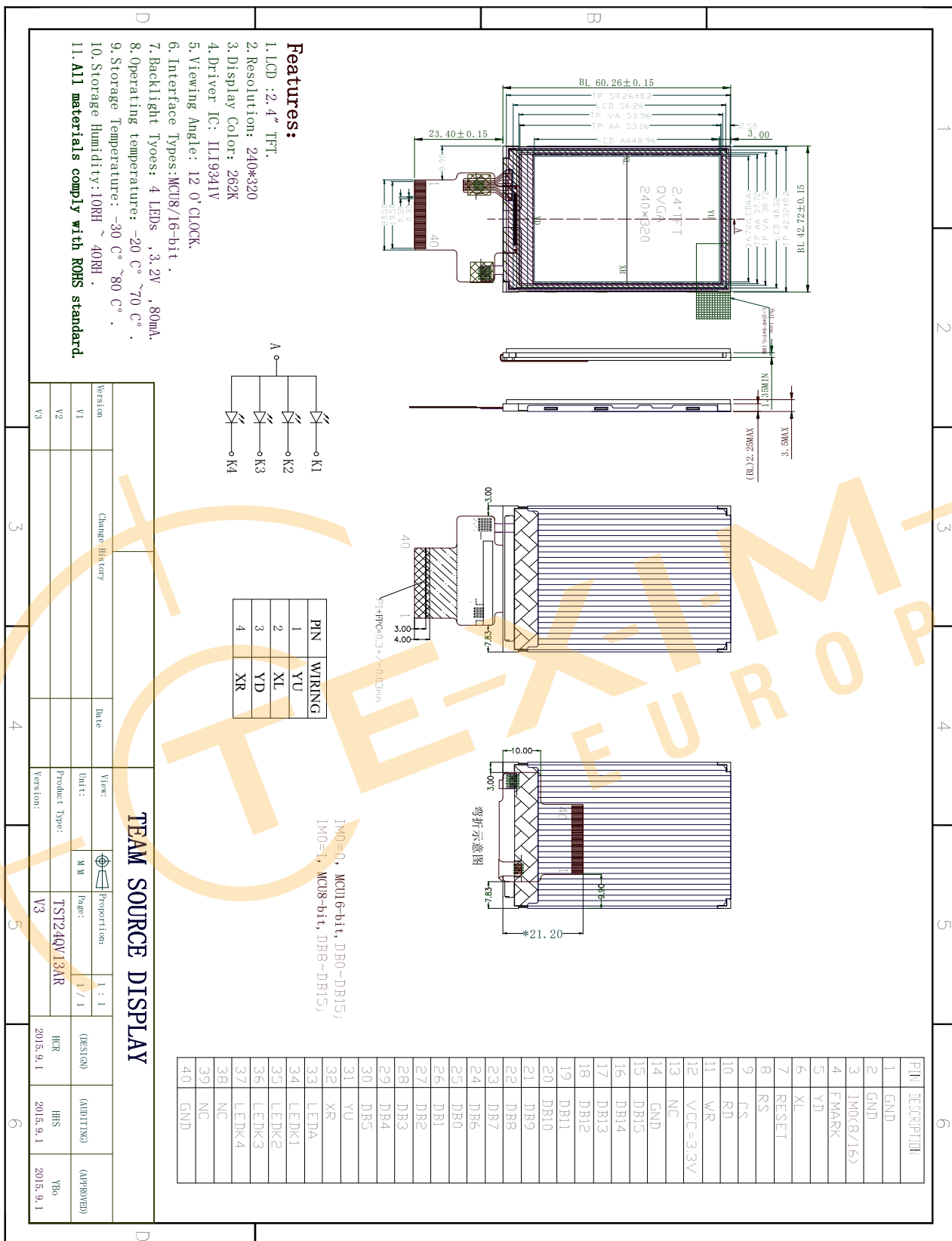

2 Interface description

| PIN NO. | Symbol | description |
|---------|-------------|---|
| 1 | GND | System Ground. (0V) |
| 2 | GND | System Ground. (0V) |
| 3 | IM0 | IM0=0: MCU16-BIT, DB0~DB15 IM0=1: MCU8-BIT, DB8~DB15 |
| 4 | FMARK | Tearing Effect output signal |
| 5 | YD | The touch panel Y Down pin |
| 6 | XL | The touch panel X Left pin |
| 7 | RESET | Reset input signal |
| 8 | RS | Data/Command Selection pin |
| 9 | CS | Chip select signal. |
| 10 | RD | read signal |
| 11 | WR | serves as a write signal |
| 12 | VCC | Power supply +2.8V |
| 13 | NC | |
| 14 | GND | System Ground. (0V) |
| 15~24 | DB15~DB6 | Data BUS |
| 25~30 | DB0~DB5 | Data BUS |
| 31 | YU | The touch panel Y Up pin |
| 32 | XR | The touch panel X Right pin |
| 33 | LEDA | Backlight A Aothod input pin. |
| 34~39 | LEDK1~LEDK6 | Backlight K Cathode input pin. |
| 40 | GND | System Ground. (0V) |

3 LCM Interface Timing

3.1 Reset Timing

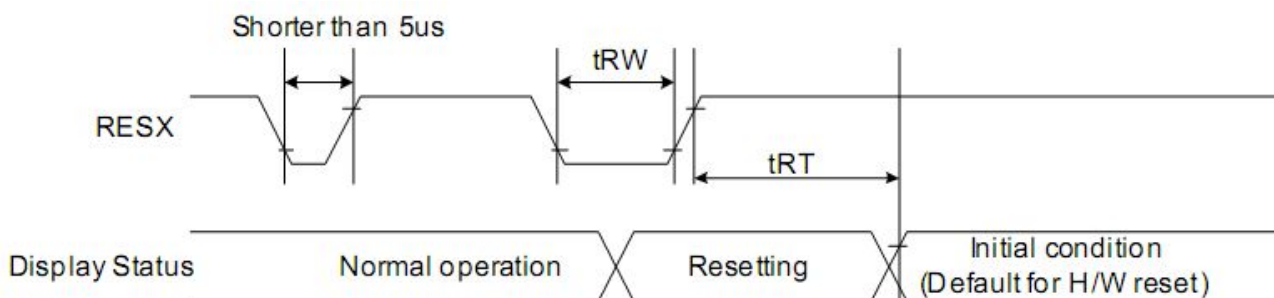

| Signal | Symbol | Parameter | Min. | Max. | Unit |
|--------|--------|-----------------------|------|-------------|------|
| RESX | tRW | Reset low pulse width | 10 | - | us |
| | tRT | Reset complete time | - | 5 (note 1) | ms |
| | | | - | 120(note 2) | ms |

Note: (1) When reset applied during SLPIN mode;

(2) When reset applied during SLPOUT mode.

3.2 MCU Read/Write Timing

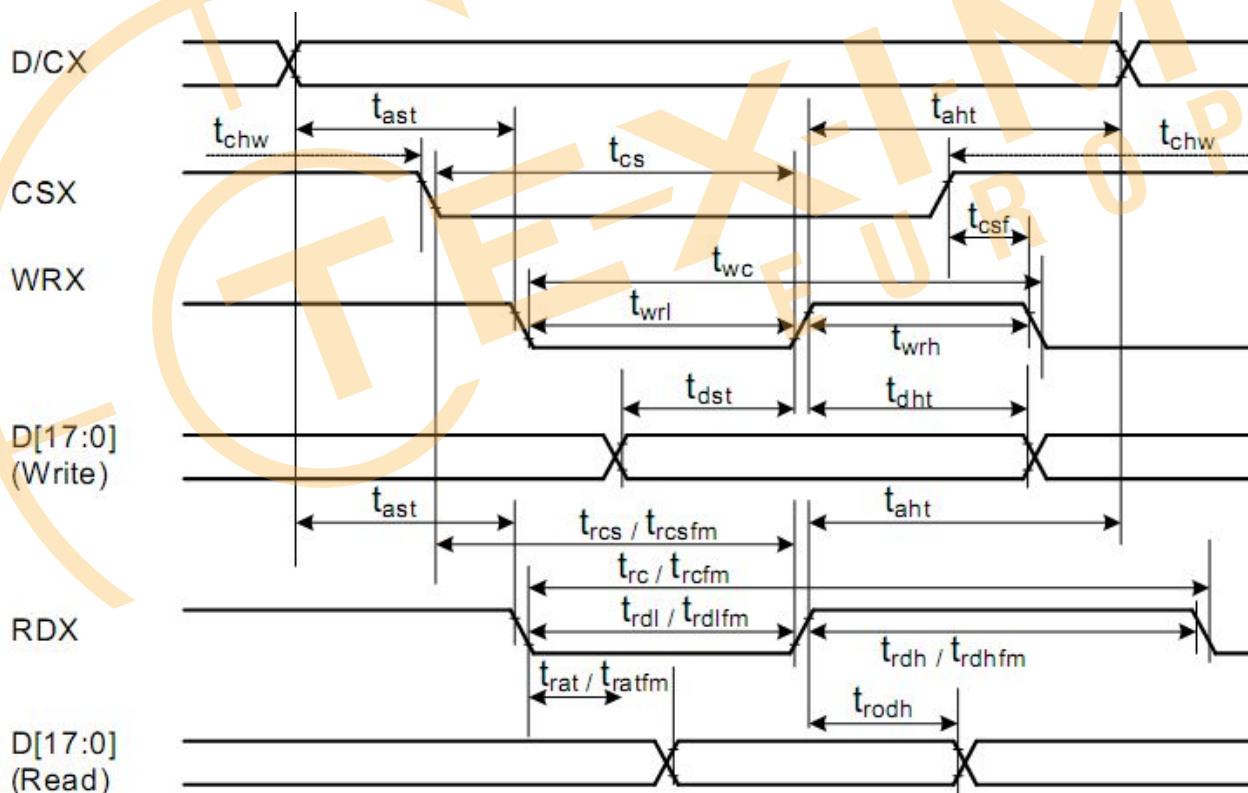

(Ta = 30 to 70 °C, IOVCC=1.65V to 3.3V, VCC=2.5V to 3.3V, VSS=0V)

| Signal | Symbol | Parameter | Min. | Max. | Unit | Description |
|----------|--------|---|------|------|------|---|
| DCX | tAST | Address setup time | 0 | - | ns | - |
| | tAHT | Address hold time (Write/Read) | 0 | - | | |
| CSX | tCS | Chip select setup time (Write) | 15 | - | ns | - |
| | tRCS | Chip select setup time (Read register) | 45 | - | | |
| | tRCSFM | Chip select setup time (GRAM) | 355 | - | | |
| | tCSF | Chip select wait time (Write/Read) | 10 | - | | |
| WRX | tWC | Write cycle (write register) | 66 | - | ns | - |
| | tWRH | Control pulse "H" duration | 15 | - | | |
| | tWRL | Control pulse "L" duration | 15 | - | | |
| RDX | tRC | Read cycle (read register) | 160 | - | ns | - |
| | tRC | Read cycle (GRAM) | 450 | - | | |
| | tRDH | Control pulse "H" duration | 90 | - | | |
| | tRDL | Control pulse "L" duration(read register) | 45 | - | | |
| | tRDL | Control pulse "L" duration(GRAM) | 355 | - | | |
| DB[23:0] | tDST | Data setup time | 10 | - | ns | For maximum CL=30pF For minimum CL=8pF |
| | tDHT | Data hold time | 10 | - | | |
| | tRAT | Read access time(read register) | - | 40 | | |
| | tRAT | Read access time(GRAM) | - | 340 | | |
| | tODH | Output disable time | 20 | 80 | | |

Note: The input signal rise time and fall time (tr, tf) is specified at 15 ns or less.

Logic high and low levels are specified as 30% and 70% of IOVCC for Input signals.

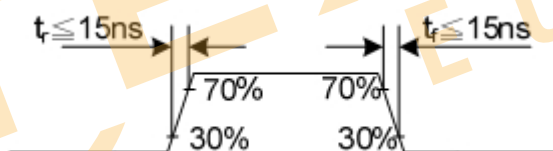

4 INITIAL CODE

```
LCD_REST=0; // Hardware reset
Delayms(15);
LCD_REST=1;
Delayms(120);
//***** Start Initial Sequence *****/
```

```
write_reg(0xCF);
write_dat(0x00);
write_dat(0xC1);
write_dat(0X30);
```

```
write_reg(0xED);
write_dat(0x64);
```

```
write_dat(0x03);  
write_dat(0X12);  
write_dat(0X81);
```

```
write_reg(0xE8);  
write_dat(0x85);  
write_dat(0x10);  
write_dat(0x7A);
```

```
write_reg(0xCB);  
write_dat(0x39);  
write_dat(0x2C);  
write_dat(0x00);  
write_dat(0x34);  
write_dat(0x02);
```

```
write_reg(0xF7);  
write_dat(0x20);
```

```
write_reg(0xEA);  
write_dat(0x00);  
write_dat(0x00);
```

```
write_reg(0xC0); //Power control  
write_dat(0x21); //VRH[5:0]
```

```
write_reg(0xC1); //Power control  
write_dat(0x13); //SAP[2:0];BT[3:0]
```

```
write_reg(0xC5); //VCM control  
write_dat(0x32);  
write_dat(0x3C);
```

```
write_reg(0xC7); //VCM control2  
write_dat(0X9C);
```

```
write_reg(0x36); // Memory Access Control  
write_dat(0x08);  
write_reg(0x3A);  
write_dat(0x55);
```

```
write_reg(0xB1);  
write_dat(0x00);  
write_dat(0x16);
```

```
write_reg(0xB6); // Display Function Control
write_dat(0x0A);
write_dat(0xA2);
```

```
write_reg(0xF6);
write_dat(0x01);
write_dat(0x30);
```

```
write_reg(0xF2); // 3Gamma Function Disable
write_dat(0x00);
```

```
write_reg(0x26); //Gamma curve selected
write_dat(0x01);
```

```
write_reg(0xE0); //Set Gamma
```

```
write_dat(0x0F);
write_dat(0x1E);
write_dat(0x1B);
write_dat(0x0B);
write_dat(0x0E);
write_dat(0x08);
write_dat(0x47);
write_dat(0xB7);
write_dat(0x37);
write_dat(0x0B);
write_dat(0x14);
write_dat(0x05);
write_dat(0x0C);
write_dat(0x07);
write_dat(0x00);
```

```
write_reg(0XE1); //Set Gamma
```

```
write_dat(0x00);
write_dat(0x21);
write_dat(0x24);
write_dat(0x04);
write_dat(0x11);
write_dat(0x07);
write_dat(0x38);
write_dat(0x48);
write_dat(0x48);
write_dat(0x04);
write_dat(0x0B);
```



```
write_dat(0x0A);
write_dat(0x33);
write_dat(0x38);
write_dat(0x0F);
```

```
write_reg(0x11); //Exit Sleep
Delaysms(120);
write_reg(0x29); //Display on
```

5 Absolute Maximum Ratings

| PARAMETER | SYMBOL | MIN. | MAX. | UNIT |
|----------------------------|-----------|------|----------------|------|
| Supply Voltage (Analog) | VCC~GND | -0.3 | 4.6 | V |
| Logic signal voltage(I/O) | IOVCC~GND | -0.3 | 4.6 | V |
| Operating Temperature | Top | -20 | 70 | ° C |
| Storage Temperature | Tst | -30 | 80 | ° C |
| Operating Ambient Humidity | Hop | 10 | 90%(Max 60° C) | RH |

6 Electrical Characteristics

| PARAMETER | SYMBOL | MIN. | TYP. | MAX. | UNIT |
|--------------------------|--------|----------|------|----------|------|
| Analog operating voltage | VCC | 2.5 | 2.8 | 3.3 | V |
| Logic operating voltage | IOVCC | 1.65 | 1.8 | 3.3 | V |
| Input Current | IDD | - | TBD | - | mA |
| Input Voltage 'H' level | VIH | 0.7IOVCC | - | IOVCC | V |
| Input Voltage 'L' level | VIL | GND | - | 0.3IOVCC | |
| Output Voltage 'H' level | VOH | 0.8IOVCC | - | IOVCC | |
| Output Voltage 'L' level | VOL | GND | - | 0.2IOVCC | |

7 Backlight Characteristics

| ITEM | SYMBOL | MIN. | TYP. | MAX. | UNIT |
|---------------------------|-----------------|-------|-------|------|------|
| Voltage for LED backlight | V _f | - | 3.2 | 3.4 | V |
| Current for LED backlight | I _f | - | 80 | - | mA |
| Power consumption | W _{bl} | - | 256 | - | mW |
| Uniformity | Avg | 80 | - | - | % |
| LED Life Time | - | 30000 | 40000 | - | |

Note:

1. The LED life time is defined as the module brightness decrease to 50% original brightness at Ta=25°C, 60%RH ±5 %.
2. The life time of LED will be reduced if LED is driven by high current, high ambient temperature and humidity conditions.
3. Typical operating life time is an estimated data.
4. Permanent damage to the device may occur if maximum values are exceeded or reverse voltage is loaded .Functional operation should be restricted to the conditions described under normal operating conditions.

8 LCD optical specifications

With Resistive touch panel

| Item | Symbol | Condition | Specification | | | Unit | Remark |
|---|--------|----------------------------|---------------|-------|-------|-------------------|------------|
| | | | Min. | Typ. | Max. | | |
| Response time (By Quick) | Tr+Tf | $\theta = 0^\circ$ | - | 30 | - | ms | Note 5 |
| Contrast ratio | CR | $\theta = 0^\circ$ | - | 250 | - | | Note 2,6 |
| Viewing angle | Top | $CR \geq 10$ | - | 55 | - | Deg. | Note 2,6,7 |
| | Bottom | $CR \geq 10$ | - | 35 | - | | |
| | Left | $CR \geq 10$ | - | 55 | - | | |
| | Right | $CR \geq 10$ | - | 55 | - | | |
| Color chromaticity (CF only with ITO, light source is C light, CIE 1931) | Wx | $\theta = 0^\circ$ | 0.288 | 0.308 | 0.328 | | Note 3 |
| | Wy | | 0.305 | 0.325 | 0.345 | | |
| | Rx | | 0.592 | 0.612 | 0.632 | | |
| | Ry | | 0.309 | 0.329 | 0.349 | | |
| | Gx | | 0.279 | 0.299 | 0.319 | | |
| | Gy | | 0.547 | 0.567 | 0.587 | | |
| | Bx | | 0.124 | 0.144 | 0.164 | | |
| | By | | 0.090 | 0.110 | 0.130 | | |
| NTSC | | | | 60% | | Note 3 | |
| Transmittance (with Polarizer) | T(%) | $\theta = 0^\circ$ | 4.5 | 5.0 | - | % | |
| Luminous | L | Viewing normal angle | --- | 304 | -- | Cd/m ² | |

Without Resistive touch panel

| Item | Symbol | Condition | Specification | | | Unit | Remark |
|---------------|--------|----------------------------|---------------|------|------|-------------------|------------|
| | | | Min. | Typ. | Max. | | |
| Viewing angle | Top | $CR \geq 10$ | - | 60 | - | Deg. | Note 2,6,7 |
| | Bottom | $CR \geq 10$ | - | 40 | - | | |
| | Left | $CR \geq 10$ | - | 60 | - | | |
| | Right | $CR \geq 10$ | - | 60 | - | | |
| Luminous | L | Viewing normal angle | --- | 376 | -- | Cd/m ² | |

Note 1: Ambient temperature = 25°C.

Note 2: To be measured with a viewing cone of 2° by Topcon luminance meter BM-5A.

Note 3: To be measured with Otsuta chromaticity meter LCF-2100M, CF only measure under C light simulation.

Note 4: CTC shipping status is cell with polarizer. Transmittance of Specification is cell with polarizer. The tolerance of Transmittance is $\pm 10\%$.

Note 5: Definition of response time:

The output signals of TRD-100 are measured when the input signals are changed to “White” (falling time) and from “White” to “Black” (rising time), respectively. The interval is between the 10% and 90% of amplitudes. Refer to figure as below.

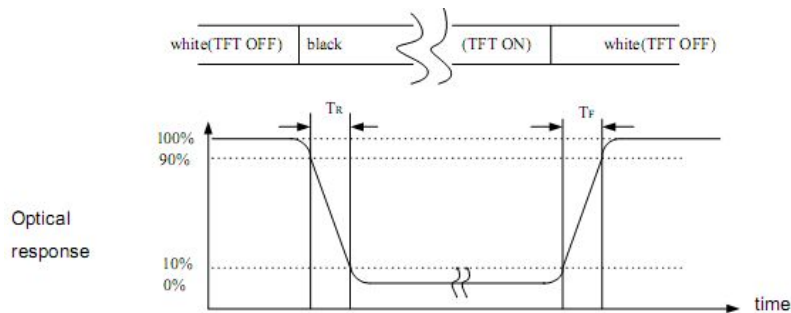

Note 6: Definition of contrast ratio:

Contrast ratio is calculated by the following formula.

$$\text{Contrast ratio (CR)} = \frac{\text{Brightness on the "white" state}}{\text{Brightness on the "black" state}}$$

Note 7: Definition of viewing angle

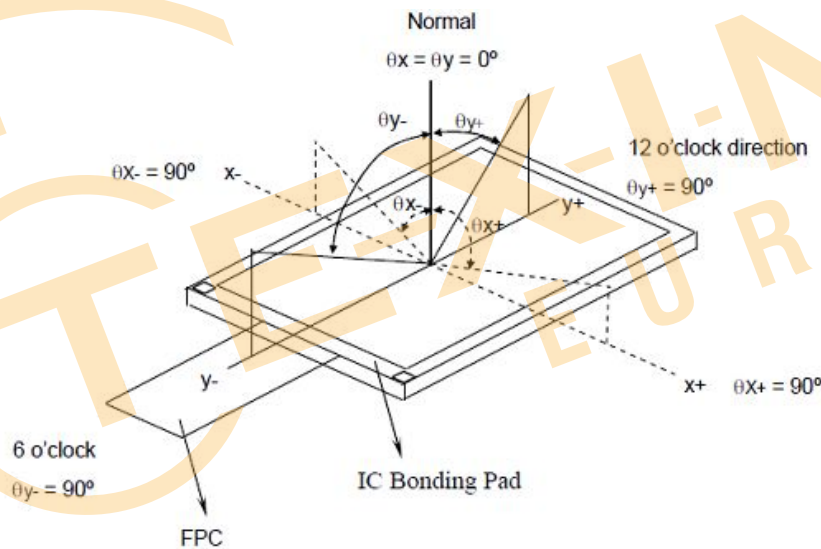

Note 8: Optical characteristic measurement setup.

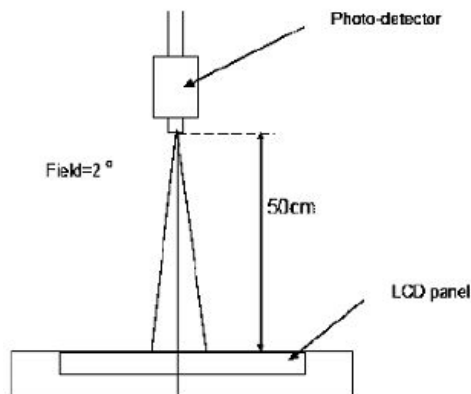

Note 9:

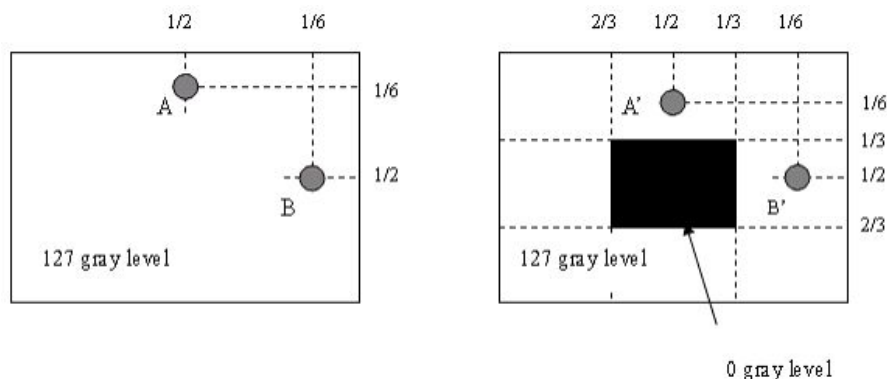

$|LA - LA'| / LA \times 100\% = 2\% \text{ max.}$, LA and LA' are brightness at location A and A'.

$|LB - LB'| / LB \times 100\% = 2\% \text{ max.}$, LB and LB' are brightness at location B and B'.

9 Touch Panel specifications

| ITEM | VALUE | | | UNIT | REMARK |
|-----------------------|-----------|------|--------|------------|---------------------------|
| | Min. | Typ. | Max. | | |
| Linearity | - | - | 1.5 | % | Analog X and Y directions |
| Terminal Resistance | 200 | - | 500 | Ω | x |
| | 350 | - | 850 | | y |
| Insulation Resistance | 10 | - | - | M Ω | DC 25V |
| Voltage | - | 3 | 10 | V | DC |
| Chattering | - | - | 15 | ms | 100k Ω pull-up |
| Transparency | 80 | - | - | % | - |
| Operation Force | - | - | 100 | g | - |
| Endurance | 1,000,000 | - | - | Touches | 100g Operation Force |
| | - | - | 30,000 | Slides | |
| Surface Hardness | 3 | - | - | H | - |

10 RELIABILITY TEST

| NO. | TEST ITEM | TEST CONDITION | INSPECTION AFTER TEST |
|-----|----------------------------|--|--|
| 1 | High Temperature Storage | 80 \pm 2 $^{\circ}$ C/96 hours | Inspection after 2~4 hours storage at room temperature and humidity. The condensation is not accepted. The sample shall be free from defects: 1. Air bubble in the LCD 2. Seal leak 3. Non-display 4. Missing segments 5. Glass crack |
| 2 | Low Temperature Storage | -30 \pm 2 $^{\circ}$ C/96 hours | |
| 3 | High Temperature Operating | 70 \pm 2 $^{\circ}$ C/96 hours | |
| 4 | Low Temperature Operating | -20 \pm 2 $^{\circ}$ C/96 hours | |
| 5 | Temperature Cycle | -30 \pm 2 $^{\circ}$ C ~ 25 ~ 80 \pm 2 $^{\circ}$ C \times 10 cycles (30 min.) (5min.) (30min.) | |

| | | | |
|----|------------------------------|--|--|
| 6 | Damp Proof Test | 60°C ±5°C × 90%RH/96 hours | |
| 7 | Vibration Test | Frequency 10Hz~55Hz Stroke: 1.5mm Sweep: 10Hz~150 Hz~10Hz 2 hours For each direction of X, Y, Z | |
| 8 | Shock Test | Half-sine, wave, 300m/s | |
| 9 | Packing Drop Test | Height: 80 cm 1 corner, concrete floor | |
| 10 | Electrostatic Discharge Test | C=150pF, R=330 Ω Air: ±8KV 150pF/330Ω 30 times Contact: ±4KV,20 times | |

11 Inspection standards

11.1 Visual inspection criterion in cosmetic

11.1.1 Glass defect

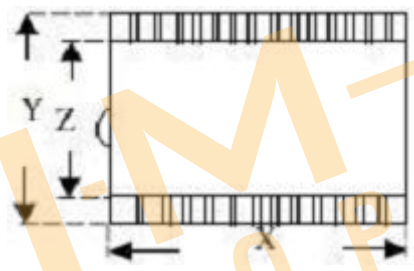
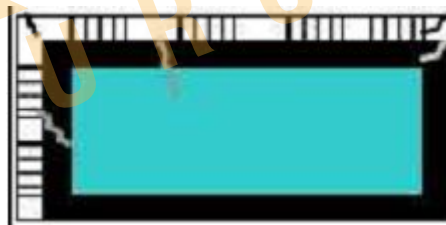
| NO. | Defect | Criteria | Remark |
|-----|------------------|--------------------------|--|
| 1 | Dimension(Minor) | By engineering diagram |  |
| 2 | Cracks(Major) | Extensive crack [Reject] |  |

11.1.2 LCM appearance defect

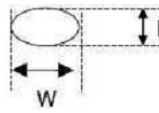
| NO. | Defect | Criteria | | Remark |
|-----|-------------------|---|-----------------|---|
| | | Spec | Permissible Qty | |
| 1 | Round type(Minor) | $\phi \leq 0.1\text{mm}$ | Disregard | 1. $\phi = (W+L)/2$, L:Length, W=Width 2. Disregard if out of A.A  |
| | | $0.1\text{mm} < \phi \leq 0.2\text{mm}$ | 3 | |
| | | $\phi > 0.2\text{mm}$ | 0 | |
| 2 | Line type(Minor) | $W \leq 0.03\text{mm}$ | Disregard | 1. L:Length, W=Width 2. Disregard if out of A.A |
| | | $L \leq 3.0\text{mm}$ and $0.03\text{mm} < W \leq 0.05\text{mm}$ | 2 | |

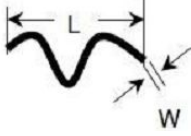
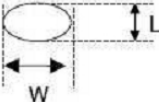
| | | | | |
|---|-----------------------|---|-----------|---|
| | | $L \leq 3.0\text{mm}$ and $0.05\text{mm} < W \leq 0.1\text{mm}$ | 1 |  |
| | | $W > 0.10\text{mm}$ or $L > 3.0\text{mm}$ | 0 | |
| 3 | Polarizer dent(Minor) | $\phi \leq 0.2\text{mm}$ | Disregard | 1. $\phi = (W+L)/2$, L:Length, W=Width 2. Disregard if out of A.A  |
| | | $0.2\text{mm} < \phi \leq 0.3\text{mm}$ | 2 | |
| | | $0.3\text{mm} < \phi \leq 0.5\text{mm}$ | 1 | |
| | | $\phi > 0.5\text{mm}$ | 0 | |

11.1.3 FPC

| NO. | Defect | Criteria | Remark |
|-----|-----------------------|-------------------------|--------|
| 1 | Copper peeling(Minor) | Copper peeling [Reject] | |
| 2 | Damaged | Damaged[Reject] | |

11.1.4 Black tape

| NO. | Defect | Criteria | Remark |
|-----|----------------------|------------------------|--------|
| 1 | Shift(Minor) | IC exposed [Reject] | |
| 2 | No black tape(Minor) | No black tape [Reject] | |



11.1.5 Silicon

| NO. | Defect | Criteria | Remark |
|-----|---------------------------|----------------------|--------|
| 1 | Amount of silicon (Minor) | ITO exposed [Reject] | |

11.1.6 Touch Panel

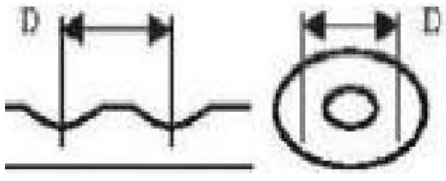
| Defect | Criteria | Remark |
|----------|--|--------|
| TP shift | Click on the TP, the distance between the show position and click position $> 1.5\text{mm}$ [Reject] | |

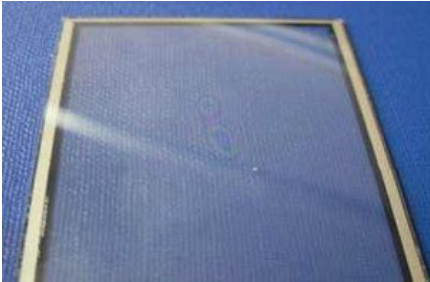
| | | | |
|---|--------------------|-----------------------|--|
| TP Circle, Dent Dot, Bubble MI | Size(mm) | Accessible QTY |  |
| | $D \leq 0.20$ | Access | |
| | $0.2 < D \leq 0.3$ | 2 | |
| | $0.3 < D \leq 0.5$ | 1 | |
| | $D > 0.5$ | 0 | |

| | | |
|--|---|---|
| <p>TP Ripple MI</p> | <p>1.(Figure A): Ripple D>5mm [Reject] 2.(Figure B): Ripple area<1/7 TP area and not impact fonts display effect [Access]</p>  |  <p>A</p>  <p>B</p> |
| <p>Remark: Tear up the protective film to inspect. The distance of two dirt must>10mm; The white dot found in manufacture is conformity to 0.1mm, if >0.1mm [Reject]</p> | | |

11.2 Visual inspection criterion in electrical display

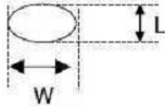
| NO. | Defect | Criteria | | Remark |
|-----|--------------------------------|--|-----------------|---|
| | | Spec. | Permissible Qty | |
| 1 | No display (Major) | Not allowed | | |
| 2 | Missing line (Major) | Not allowed | | |
| 3 | Darker or lighter Line (Major) | Not allowed | | |
| 4 | Weak line(Major) | By limited sample | | |
| 5 | Bright / Dark point (Minor) | Bright point | 1 | 1:1 sub-pixel: 1R or 1G or 1B 2:Point defect area 1/2 sub pixel. |
| | | Dark point | 2 | |
| 6 | Round type (Minor) | $\phi \leq 0.1\text{mm}$ | Disregard | 1. $\phi = (W+L)/2$, L:Length,W=Width 2.Disregard if out of A.A  |
| | | $0.1 < \phi \leq 0.2$ | 3 | |
| | | $\phi > 0.2\text{mm}$ | 0 | |
| | Line type (Minor) | $W \leq 0.03\text{mm}$ | Disregard | 1. L:Length,W=Width 2.Disregard if out of A.A |
| | | $L \leq 3.0\text{mm}$ and $0.03\text{mm} < W \leq 0.05\text{mm}$ | 2 | |
| | | $L \leq 3.0\text{mm}$ and $0.05\text{mm} < W \leq 0.1\text{mm}$ | 1 | |

| | | | | |
|--|--------------|---|---|--|
| | | $W > 0.10\text{mm}$ or $L > 3.0\text{mm}$ | 0 | |
| | Mura (Minor) | By 5% ND filter invisible | | |

11.3 Others

1. Issues that are not defined in this document shall be discussed and agreed with both parties. (Customer and supplier)
2. Unless otherwise agreed upon in writing, the criteria shall be applied to both parties. (Customer and supplier)

12 Suggestions for using LCD modules

12.1 Handling of LCM

1. The LCD screen is made of glass. Don't give excessive external shock, or drop from a high place.
2. If the LCD screen is damaged and the liquid crystal leaks out, do not lick and swallow. When the liquid is attach to your hand, skin, cloth etc, wash it off by using soap and water thoroughly and immediately.
3. Don't apply excessive force on the surface of the LCM.
4. If the surface is contaminated, clean it with soft cloth. If the LCM is severely contaminated, use Isopropyl alcohol/Ethyl alcohol to clean. Other solvents may damage the polarizer. The following solvents is especially prohibited: water , ketone Aromatic solvents etc.
5. Exercise care to minimize corrosion of the electrode. Corrosion of the electrodes is accelerated by water droplets, moisture condensation or a current flow in a high-humidity environment.
6. Install the LCD Module by using the mounting holes. When mounting the LCD module make sure it is free of twisting, warping and distortion. In particular, do not forcibly pull or bend the I/O cable or the backlight cable.
7. Don't disassemble the LCM.
8. To prevent destruction of the elements by static electricity, be careful to maintain an optimum work environment.
 - Be sure to ground the body when handling the LCD modules.
 - Tools required for assembling, such as soldering irons, must be properly grounded.
 - To reduce the amount of static electricity generated, do not conduct assembling and other work under dry conditions.
 - The LCD module is coated with a film to protect the display surface. Exercise care when peeling

off this protective film since static electricity may be generated.

9. Do not alter, modify or change the the shape of the tab on the metal frame.

10. Do not make extra holes on the printed circuit board, modify its shape or change the positions of components to be attached.

11. Do not damage or modify the pattern writing on the printed circuit board.

12. Absolutely do not modify the zebra rubber strip (conductive rubber) or heat seal connector

13. Except for soldering the interface, do not make any alterations or modifications with a soldering iron.

14. Do not drop, bend or twist LCM.

12.2 Storage

1. Store in an ambient temperature of 5 to 45 °C, and in a relative humidity of 40% to 60%. Don't expose to sunlight or fluorescent light.

2. Storage in a clean environment, free from dust, active gas, and solvent.

3. Store in antistatic container.



Disclaimer

ALL PRODUCTS, PRODUCT SPECIFICATIONS AND DATA ARE SUBJECT TO CHANGE WITHOUT NOTICE TO IMPROVE RELIABILITY, FUNCTION OR DESIGN OR OTHERWISE.

Texim Europe B.V. its affiliates, agents, and employees, and all persons acting on its or their behalf (collectively, "Texim"), disclaim any and all liability for any errors, inaccuracies or incompleteness contained in any datasheet or in any other disclosure relating to any product.

Texim makes no warranty, representation or guarantee regarding the suitability of the products for any particular purpose or the continuing production of any product.

It is the customer's responsibility to validate that a particular product with the properties described in the product specification is suitable for use in a particular application.

Parameters provided in datasheets and / or specifications may vary in different applications and performance may vary over time.

All operating parameters, including typical parameters, must be validated for each customer application by the customer's technical experts.

Please contact us if you have any questions about the contents of the datasheet.

This may not be the latest version of the datasheet. Please check with us if a later version is available.

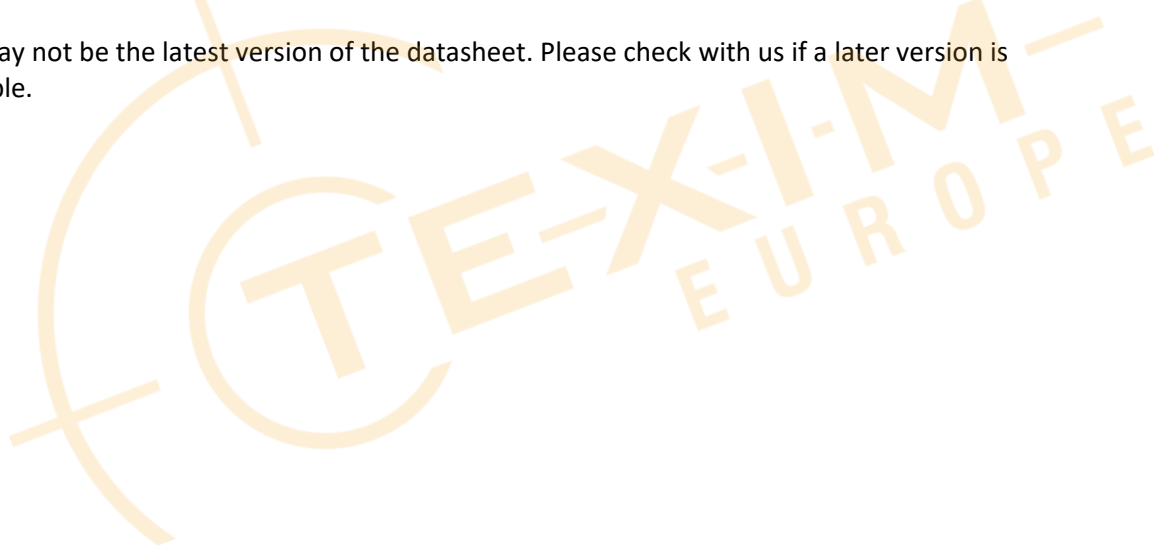



Headquarters & Warehouse

Elektrostraat 17
NL-7483 PG Haaksbergen
The Netherlands

T: +31 (0)53 573 33 33
E: info@texim-europe.com
Homepage: www.texim-europe.com



The Netherlands

Elektrostraat 17
NL-7483 PG Haaksbergen

T: +31 (0)53 573 33 33
E: nl@texim-europe.com



Belgium

Zuiderlaan 14, box 10
B-1731 Zellik

T: +32 (0)2 462 01 00
E: belgium@texim-europe.com



UK & Ireland

St Mary's House, Church Lane
Carlton Le Moorland
Lincoln LN5 9HS

T: +44 (0)1522 789 555
E: uk@texim-europe.com



Germany - North

Bahnhofstrasse 92
D-25451 Quickborn

T: +49 (0)4106 627 07-0
E: germany@texim-europe.com



Germany - South

Martin-Kollar-Strasse 9
D-81829 München

T: +49 (0)89 436 086-0
E: muenchen@texim-europe.com



Austria

Warwitzstrasse 9
A-5020 Salzburg

T: +43 (0)662 216 026
E: austria@texim-europe.com



Nordic

Søndre Jagtvej 12
DK-2970 Hørsholm

T: +45 88 20 26 30
E: nordic@texim-europe.com



Italy

Martin-Kollar-Strasse 9
D-81829 München

T: +49 (0)89 436 086-0
E: italy@texim-europe.com