



Product Specification

G190EG02 V1 (V104)

AU OPTRONICS CORPORATION

- () Preliminary Specifications
- (v) Final Specifications

Distributed by:



www.texim-europe.com

Module	19.0 Inch Color TFT-LCD
Model Name	G190EG02 V1 (V104)

Customer	Date
_____	_____
Checked & Approved by	Date
_____	_____
Customer's sign back page	

Approved by	Date
<u>Crystal Hsieh</u>	<u>2018.08.03</u>
Prepared by	Date
<u>BinJou Huang</u>	<u>2018.08.03</u>
General Display Business Division / AU Optronics corporation	



Contents

1. Operating Precautions	4
2. General Description	5
2.1 Display Characteristics.....	5
2.2 Optical Characteristics	6
3. Functional Block Diagram	9
4. Absolute Maximum Ratings	10
4.1 Absolute Ratings of TFT LCD Module.....	10
4.2 Absolute Ratings of Environment.....	10
5. Electrical Characteristics	11
5.1 TFT LCD Module	11
5.2 Backlight Unit.....	13
6. Signal Characteristic	15
6.1 Pixel Format Image.....	15
6.2 Signal Description	16
6.3 The Input Data Format.....	18
6.4 Interface Timing	19
6.5 Power ON/OFF Sequence	20
7. Reliability Test Criteria	21
8. Mechanical Characteristics	22
8.1 LCM Outline Dimension (Front View).....	22
8.2 LCM Outline Dimension (Rear View)	23
9. Label and Packaging	24
9.1 Shipping Label	24
9.2 Carton Package	24
10 Safety	25
10.1 Sharp Edge Requirements.....	25
10.2 Materials	25
10.3 Capacitors.....	25
10.4 National Test Lab Requirement.....	25



Record of Revision

Version	Date (yyyy/m/d)	Page	Old description	New Description																																								
1.0	2017/8/18	All	First draft specification																																									
1.1	2017/10/20	14	<p>Backlight input signal characteristics</p> <table border="1"> <thead> <tr> <th>Symbol</th> <th>Parameter</th> <th>Min</th> <th>Typ</th> <th>Max</th> <th>Units</th> </tr> </thead> <tbody> <tr> <td>V_{LED} (Note 1)</td> <td>LED Power Supply</td> <td>13.5</td> <td>15</td> <td>16.5</td> <td>[Volt]</td> </tr> </tbody> </table>	Symbol	Parameter	Min	Typ	Max	Units	V _{LED} (Note 1)	LED Power Supply	13.5	15	16.5	[Volt]	<p>Backlight input signal characteristics</p> <table border="1"> <thead> <tr> <th>Symbol</th> <th>Parameter</th> <th>Min</th> <th>Typ</th> <th>Max</th> <th>Units</th> <th>Remark</th> </tr> </thead> <tbody> <tr> <td>V_{LED} (Note 1)</td> <td>LED Power Supply</td> <td>---</td> <td>12</td> <td>---</td> <td>[Volt]</td> <td>1</td> </tr> </tbody> </table>	Symbol	Parameter	Min	Typ	Max	Units	Remark	V _{LED} (Note 1)	LED Power Supply	---	12	---	[Volt]	1														
Symbol	Parameter	Min	Typ	Max	Units																																							
V _{LED} (Note 1)	LED Power Supply	13.5	15	16.5	[Volt]																																							
Symbol	Parameter	Min	Typ	Max	Units	Remark																																						
V _{LED} (Note 1)	LED Power Supply	---	12	---	[Volt]	1																																						
1.2	2018/01/31	21		Add Altitude Test																																								
1.3	2018/08/03	6	Color Gamut 70%	Color Gamut 72%																																								
	2018/08/03	11	<table border="1"> <thead> <tr> <th>VDD Current</th> <th>Min</th> <th>Typ</th> <th>Max</th> <th>Units</th> </tr> </thead> <tbody> <tr> <td></td> <td>0.66</td> <td>0.63</td> <td></td> <td>[mA]</td> </tr> </tbody> </table>	VDD Current	Min	Typ	Max	Units		0.66	0.63		[mA]	<table border="1"> <thead> <tr> <th>VDD Current</th> <th>Min</th> <th>Typ</th> <th>Max</th> <th>Units</th> </tr> </thead> <tbody> <tr> <td></td> <td>0.63</td> <td>0.66</td> <td></td> <td></td> </tr> </tbody> </table>	VDD Current	Min	Typ	Max	Units		0.63	0.66																						
VDD Current	Min	Typ	Max	Units																																								
	0.66	0.63		[mA]																																								
VDD Current	Min	Typ	Max	Units																																								
	0.63	0.66																																										
	2018/08/03	14	<table border="1"> <thead> <tr> <th>LED Input Current</th> <th>Min</th> <th>Typ</th> <th>Max</th> <th>Units</th> </tr> </thead> <tbody> <tr> <td></td> <td>---</td> <td>0.906</td> <td>---</td> <td></td> </tr> <tr> <th>Power Consumption</th> <th>Min</th> <th>Typ</th> <th>Max</th> <th>Units</th> </tr> <tr> <td></td> <td>---</td> <td>13.6</td> <td>15</td> <td></td> </tr> </tbody> </table>	LED Input Current	Min	Typ	Max	Units		---	0.906	---		Power Consumption	Min	Typ	Max	Units		---	13.6	15		<table border="1"> <thead> <tr> <th>LED Input Current</th> <th>Min</th> <th>Typ</th> <th>Max</th> <th>Units</th> </tr> </thead> <tbody> <tr> <td></td> <td>---</td> <td>---</td> <td>1.25</td> <td></td> </tr> <tr> <th>Power Consumption</th> <th>Min</th> <th>Typ</th> <th>Max</th> <th>Units</th> </tr> <tr> <td></td> <td>---</td> <td>---</td> <td>15</td> <td></td> </tr> </tbody> </table>	LED Input Current	Min	Typ	Max	Units		---	---	1.25		Power Consumption	Min	Typ	Max	Units		---	---	15	
LED Input Current	Min	Typ	Max	Units																																								
	---	0.906	---																																									
Power Consumption	Min	Typ	Max	Units																																								
	---	13.6	15																																									
LED Input Current	Min	Typ	Max	Units																																								
	---	---	1.25																																									
Power Consumption	Min	Typ	Max	Units																																								
	---	---	15																																									





1. Operating Precautions

- 1) Since front polarizer is easily damaged, please be cautious and not to scratch it.
- 2) Be sure to turn off power supply when inserting or disconnecting from input connector.
- 3) Wipe off water drop immediately. Long contact with water may cause discoloration or spots.
- 4) When the panel surface is soiled, wipe it with absorbent cotton or soft cloth.
- 5) Since the panel is made of glass, it may be broken or cracked if dropped or bumped on hard surface.
- 6) To avoid ESD (Electro Static Discharge) damage, be sure to ground yourself before handling TFT-LCD Module.
- 7) Do not open nor modify the module assembly.
- 8) Do not press the reflector sheet at the back of the module to any direction.
- 9) In case if a module has to be put back into the packing container slot after it was taken out from the container, do not press the center of the LED light bar edge. Instead, press at the far ends of the LED light bar edge softly. Otherwise the TFT Module may be damaged.
- 10) At the insertion or removal of the Signal Interface Connector, be sure not to rotate nor tilt the Interface Connector of the TFT Module.
- 11) TFT-LCD Module is not allowed to be twisted & bent even force is added on module in a very short time. Please design your display product well to avoid external force applying to module by end-user directly.
- 12) Small amount of materials having no flammability grade is used in the LCD module. The LCD module should be supplied by power complied with requirements of Limited Power Source (IEC60950 or UL1950), or be applied exemption.
- 13) Severe temperature condition may result in different luminance, response time and lamp ignition voltage.
- 14) Continuous operating TFT-LCD display under low temperature environment may accelerate lamp exhaustion and reduce luminance dramatically.
- 15) The data on this specification sheet is applicable when LCD module is placed in landscape position.
- 16) Continuous displaying fixed pattern may induce image sticking. It's recommended to use screen saver or shuffle content periodically if fixed pattern is displayed on the screen.



2. General Description

This specification applies to the Color Active Matrix Liquid Crystal Display G190EG02 V1(V104) composed of a TFT-LCD display, a driver and power supply circuit, and a LED backlight system. The screen format is intended to support the SXGA (1280(H) x 1024(V)) screen and 16.7M colors. LED driving board for backlight unit is included in G190EG02 V1(V104).

2.1 Display Characteristics

The following items are characteristics summary on the table under 25 °C condition:

Items	Unit	Specifications
Screen Diagonal	[inch]	19.0
Active Area	[mm]	376.32(H) x 301.06(V)
Resolution		1280(x3) x 1024
Pixel Pitch	[mm]	0.294(pre one triad) x 0.294
Pixel Arrangement		RGB Vertical Strip
Display Mode		MVA
Nominal Input Voltage VDD	[Volt]	+5(typ.)
Power Consumption	[Watt]	Logic 3.5W @ All white pattern (max.) BL 15W (max.)
Weight	[Grams]	1740g (typ.)
Physical Size	[mm]	396.0(H) x 324.0(V) x 15.3(D)(typ.)
Electrical Interface		Dual Channel LVDS
Surface Treatment		Anti-Glare
Support Color		16.7M color (8bit)
Temperature Range		
Operating	[°C]	-15 to +70
Storage (Non-Operating)	[°C]	-20 to +70
RoHS Compliance		Yes



2.2 Optical Characteristics

The optical characteristics are measured under stable conditions at 25 oC (Room Temperature):

Item	Unit	Conditions	Min.	Typ.	Max.	Note	
White Luminance	cd/m2	I _{LED} =60mA(center point)	280	350	-	1	
Uniformity	%	9 points	75	80	-	2,3	
Contrast Ratio	--		1000	2000	-	4	
Response Time	msec	Rising	-	15	25	5	
		Falling	-	5	15		
		Rising + Falling	-	20	40		
Viewing Angle	degree	Horizontal CR >= 10	(Right)	75	89	-	6
			(Left)	75	89	-	
		Vertical CR >= 10	(Upper)	75	89	-	
			(Lower)	75	89	-	
Color / Chromaticity Coordinates (CIE 1931)	--	Red x	0.593	0.643	0.693		
		Red y	0.294	0.344	0.394		
		Green x	0.277	0.327	0.377		
		Green y	0.575	0.625	0.675		
		Blue x	0.102	0.152	0.202		
		Blue y	0.002	0.052	0.102		
		White x	0.263	0.313	0.363		
		White y	0.279	0.329	0.379		
Color Gamut	%			72			

Note 1: Measurement method

Equipment Pattern Generator, Power Supply, Digital Voltmeter, Luminance meter (SR_3 or equivalent)

Aperture 1° with 50cm viewing distance

Test Point Center

Environment < 1 lux

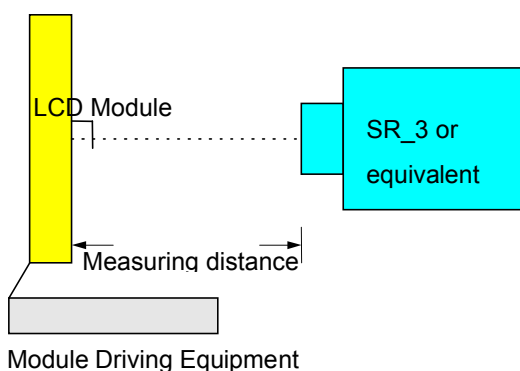



Product Specification

AU OPTRONICS CORPORATION

Note 2: Definition of 9 points position

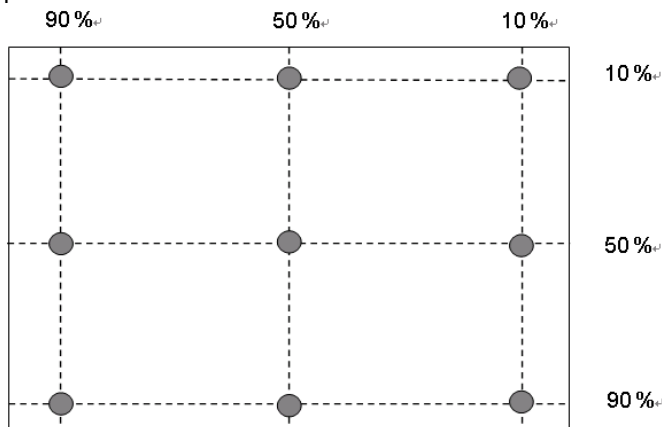

Note 3: The luminance uniformity of 9 points is defined by dividing the minimum luminance values by the maximum test point luminance

$$\delta_{w9} = \frac{\text{Minimum Brightness of 9 points}}{\text{Maximum Brightness of 9 points}}$$

Note 4: Definition of contrast ratio (CR):

$$\text{Contrast ratio (CR)} = \frac{\text{Brightness on the "White" state}}{\text{Brightness on the "Black" state}}$$

Note 5: Definition of response time:

The output signals of photo detector are measured when the input signals are changed from "White" to "Black" (falling time) and from "Black" to "White" (rising time), respectively. The response time interval is between 10% and 90% of amplitudes. Please refer to the figure as below.

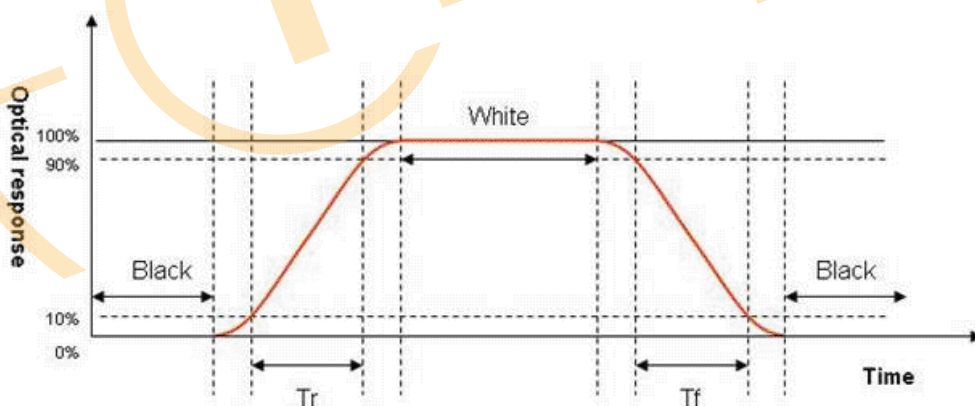



Note 6: Definition of viewing angle

Viewing angle is the measurement of contrast ratio ≥ 10 , at the screen center, over a 180° horizontal and 180° vertical range (off-normal viewing angles). The 180° viewing angle range is broken down as below: 90° (θ) horizontal left and right, and 90° (Φ) vertical high (up) and low (down). The measurement direction is typically perpendicular to the display surface with the screen rotated to its center to develop the desired measurement viewing angle.

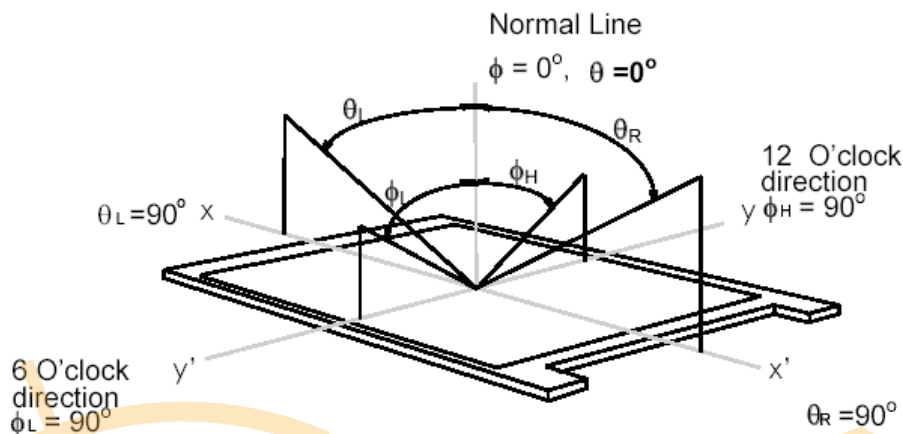



3. Functional Block Diagram

The following diagram shows the functional block of the 19.0 inch color TFT/LCD module:

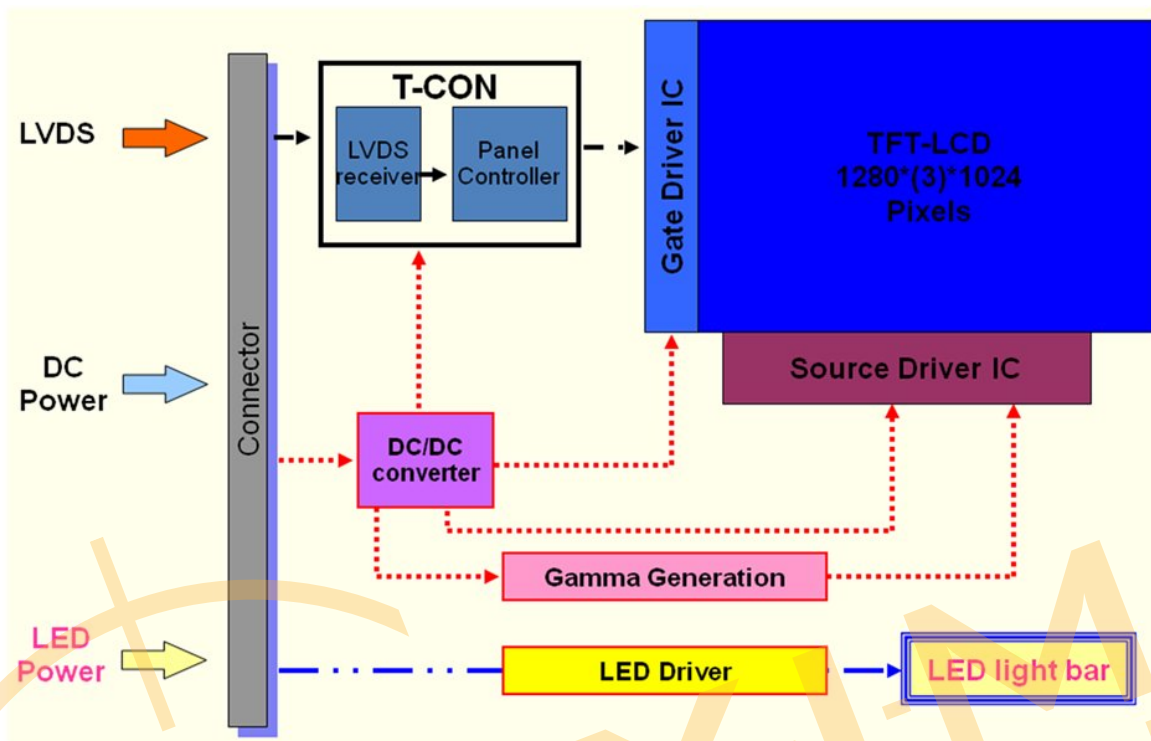



4. Absolute Maximum Ratings

4.1 Absolute Ratings of TFT LCD Module

Item	Symbol	Min	Max	Unit
Logic/LCD drive Voltage	VDD	-0.3	+5.5	[Volt]

4.2 Absolute Ratings of Environment

Item	Symbol	Min	Max	Unit
Operating Temperature	TOP	-15	+70	[°C]
Operation Humidity	HOP	5	80	[%RH]
Storage Temperature	TST	-20	+70	[°C]
Storage Humidity	HST	5	80	[%RH]

Note 1: At Ta (25°C), Maximum Wet-Bulb should be 39°C and no condensation.

Note 2: Permanent damage to the device may occur if exceed maximum values

Note 3: LED specification refer to section 5.2

Note 4: For quality performance, please refer to AUO IIS (Incoming Inspection Standard)

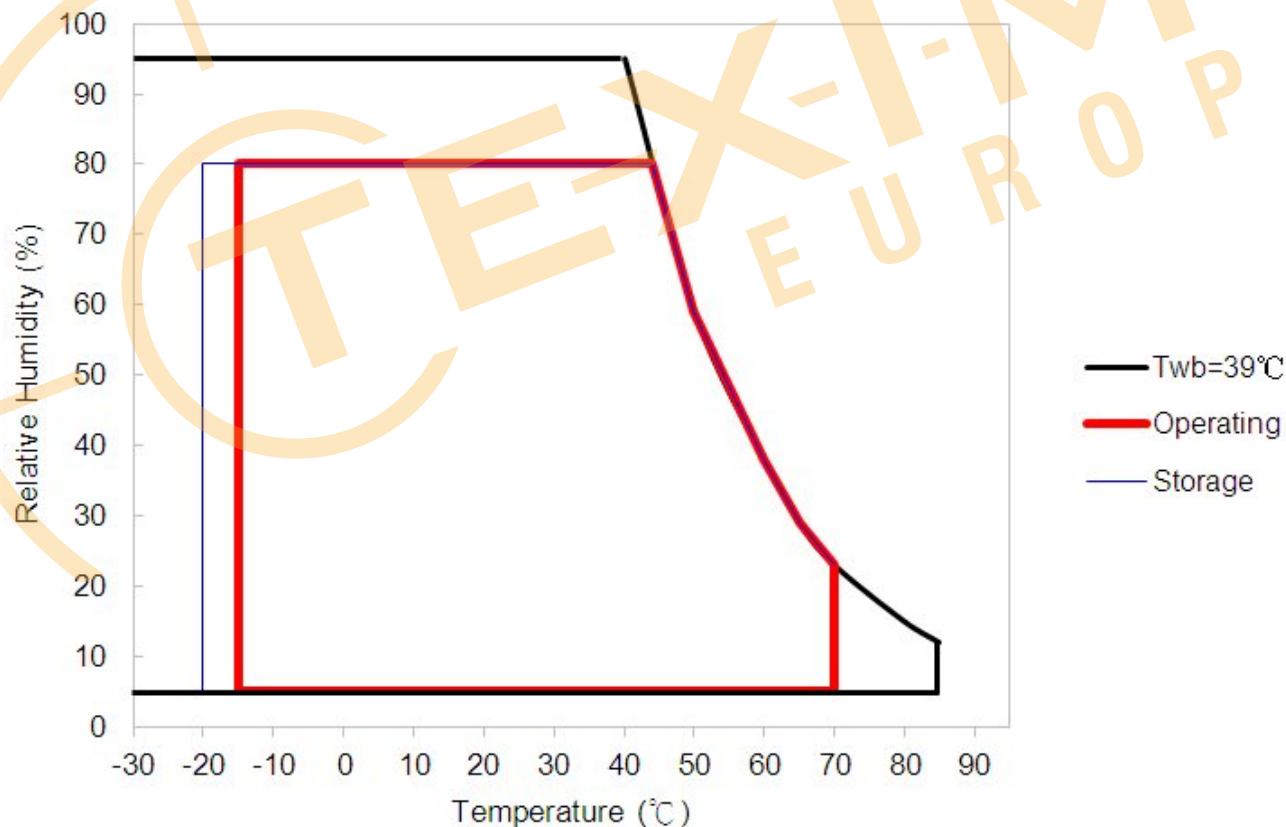



5. Electrical Characteristics

5.1 TFT LCD Module

5.1.1 Power Specification

Input power specifications are shown as follows;

Symbol	Parameter	Min	Typ	Max	Units	Remark
VDD	Logic/LCD Drive Voltage	4.5	5.0	5.5	[Volt]	
IDD	VDD Current	-	0.63	0.66	[mA]	All White Pattern (VDD=5V, at 60Hz)
IRush	LCD Inrush Current	-	2	-	[A]	Note
PDD	VDD Power	-	3.3	3.5	[Watt]	All White Pattern (VDD=5V, at 60Hz)
VDDrp	Allowable Logic/LCD Drive Ripple Voltage	-	-	300	[mV] p-p	All White Pattern (VDD=5V, at 60Hz)

Note : Measurement condition:

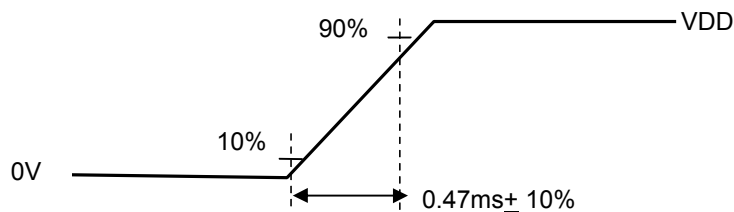
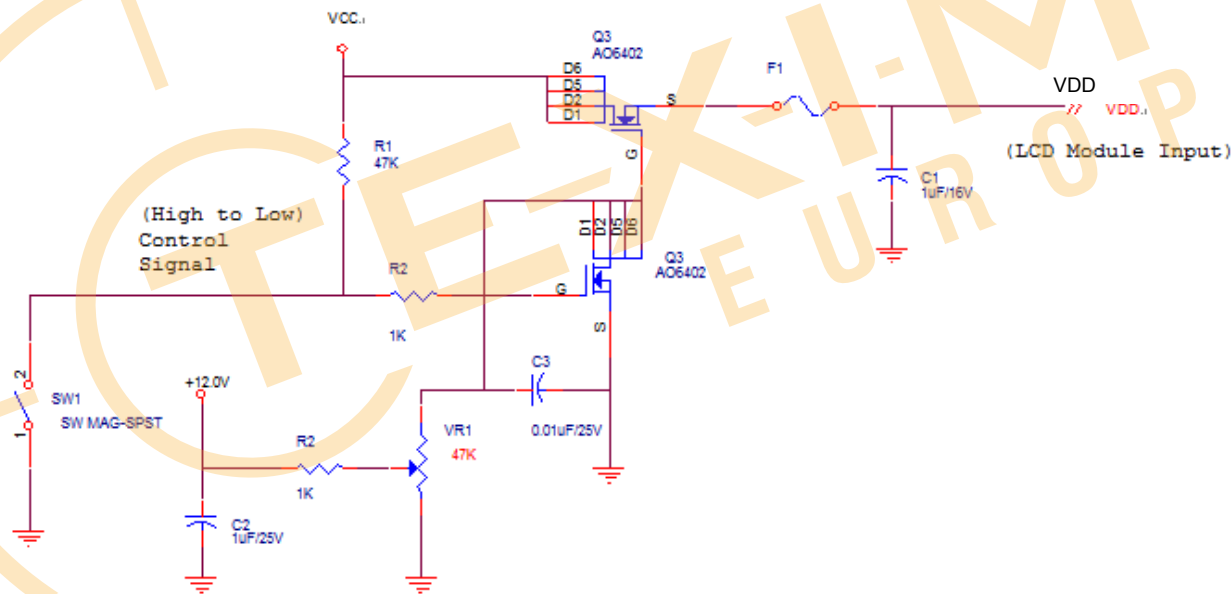

VDD rising time



5.1.2 LVDS DC Signal Electrical Characteristics

Input signals shall be low or Hi-Z state when VDD is off.

Symbol	Item	Min.	Typ.	Max.	Unit	Remark
VTH	Differential Input High Threshold	-	-	100	[mV]	VCM=1.2V
VTL	Differential Input Low Threshold	-100	-	-	[mV]	VCM=1.2V
VID	Input Differential Voltage	100	400	600	[mV]	
VICM	Differential Input Common Mode Voltage	VID /2	1.2	2.4V- VID /2	[V]	

Note: LVDS Signal Waveform.

Single-end Signal

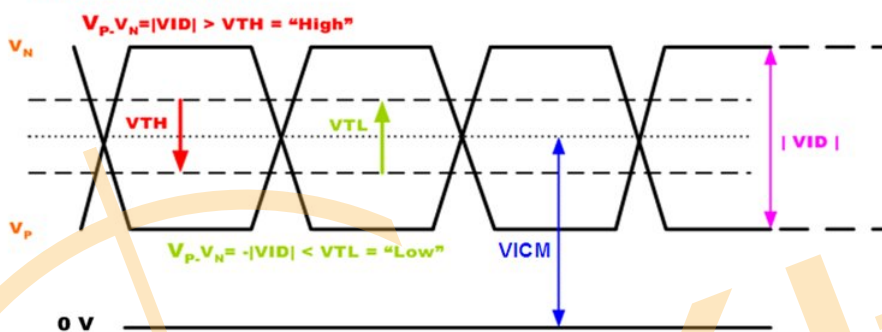

Differential Signal

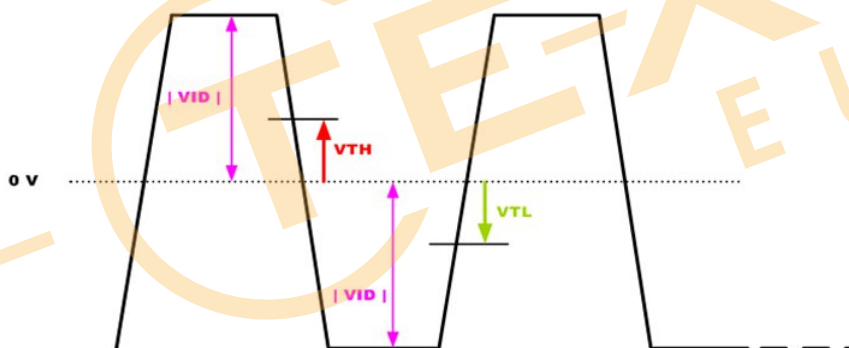



5.2 Backlight Unit

5.2.1 LED Backlight Unit: Driver Connector

Connector Name / Designation	Lamp Connector
Manufacturer	STM
Connector Model Number	MS24019RHD or compatible
Mating Model Number	P24019 or compatible

Pin No.	Symbol	Description
Pin1	V_{LED}	12V input
Pin2	V_{LED}	12V input
Pin3	V_{LED}	12V input
Pin4	NC	NC
Pin5	GND	GND
Pin6	GND	GND
Pin7	GND	GND
Pin8	V_{LED_EN}	Enable On : 2.5V(min)~5.5V(max) Enable Off (max) : 0.5V
Pin9	V_{PWM}	High : 2.5V(min)~5.5V(max); Low : 0.5V (max) V_{PWM} Duty 10%~ 100%



5.2.3 Parameter guideline for LED

Following characteristics are measured under a stable condition using an inverter at 25°C (Room Temperature):

LED characteristics

Symbol	Parameter	Min	Typ	Max	Units	Condition
LT _{LED}	LED Life-Time	50,000	--	--	Hour	No Backlight Unit

Note : The LED life-time define as the estimated time to 50% degradation of initial luminous.

Backlight input signal characteristics

Symbol	Parameter	Min	Typ	Max	Units	Remark
V _{LED} (Note 1)	LED Power Supply	--	12	--	[Volt]	
I _{LED}	LED Input Current	--	--	1.25	[A]	(100% PWM Duty)
P _{LED}	Power Consumption	--	--	15	[Watt]	(100% PWM Duty)
V _{LED_EN}	LED Enable Input High Level	2.5	--	5.5	[Volt]	Define as Connector Interface (Ta=25°C)
	LED Enable Input Low Level	--	--	0.5	[Volt]	
V _{PWM}	PWM Logic Input High Level	2.5	--	5.5	[Volt]	
	PWM Logic Input Low Level	--	--	0.5	[Volt]	
F _{PWM}	PWM Input Frequency *1	200	1K	20K	Hz	
Duty	PWM Duty Ratio	10	--	100	%	

Note1: Measured on panel VLED

Note2: Calculator value for reference $P_{LED} = V_F$ (Normal Distribution) * I_F (Normal Distribution) / Efficiency



6. Signal Characteristic

6.1 Pixel Format Image

Following figure shows the relationship between input signal and LCD pixel format.

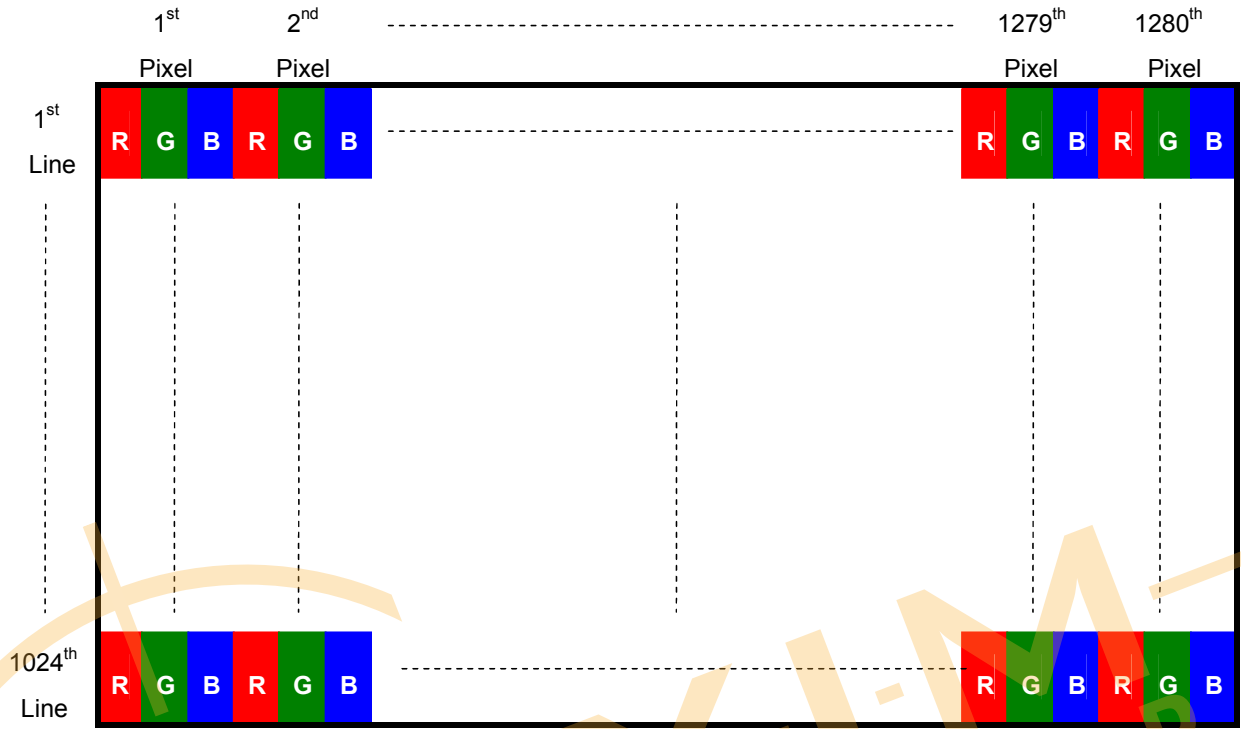



6.2 Signal Description

The module uses a LVDS receiver embedded in AUO's ASIC. LVDS is a differential signal technology for LCD interface and a high-speed data transfer device.

6.2.1 TFT LCD Module: LVDS Connector

Connector Name / Designation	Signal Connector
Manufacturer	JAE
Connector Model Number	FI-XB30SSRLAHF16-R3500
Adaptable Plug	JAE: FI-X30HL

Pin No	Symbol	Function	Remark
1	RxOIN0-	Negative LVDS differential data input (Odd data)	
2	RxOIN0+	Positive LVDS differential data input (Odd data)	
3	RxOIN1-	Negative LVDS differential data input (Odd data)	
4	RxOIN1+	Positive LVDS differential data input (Odd data)	
5	RxOIN2-	Negative LVDS differential data input (Odd data,	
6	RxOIN2+	Positive LVDS differential data input (Odd data,	
7	GND	Power Ground	
8	RxOCLKIN-	Negative LVDS differential clock input (Odd clock)	
9	RxOCLKIN+	Positive LVDS differential clock input (Odd clock)	
10	RxOIN3-	Negative LVDS differential data input (Odd data)	
11	RxOIN3+	Positive LVDS differential data input (Odd data)	
12	RxEIN0-	Negative LVDS differential data input (Even data)	
13	RxEIN0+	Positive LVDS differential data input (Even data)	
14	GND	Power Ground	
15	RxEIN1-	Negative LVDS differential data input (Even data)	
16	RxEIN1+	Positive LVDS differential data input (Even data)	
17	GND	Power Ground	
18	RxEIN2-	Negative LVDS differential data input (Even data)	
19	RxEIN2+	Positive LVDS differential data input (Even data)	
20	RxECLKIN-	Negative LVDS differential clock input (Even clock)	
21	RxECLKIN+	Positive LVDS differential clock input (Even clock)	
22	RxEIN3-	Negative LVDS differential data input (Even data)	
23	RxEIN3+	Positive LVDS differential data input (Even data)	
24	GND	Power Ground	
25	GND	Power Ground	
26	NC	Do not connect (for AUO test)	



Product Specification

AU OPTRONICS CORPORATION

27	NC	Do not connect (for AUO test)	
28	VDD	+5.0V Power Supply	
29	VDD	+5.0V Power Supply	
30	VDD	+5.0V Power Supply	

Note 1: Input Signals shall be in low status when VDD is off.

Note 2: NC means “No Connection”.

Note 3: RSV means “Reserved”.

Note 4: 30pin start from right side of connector.

Note 5: Input signals shall be low or High-impedance state when VDD is off.

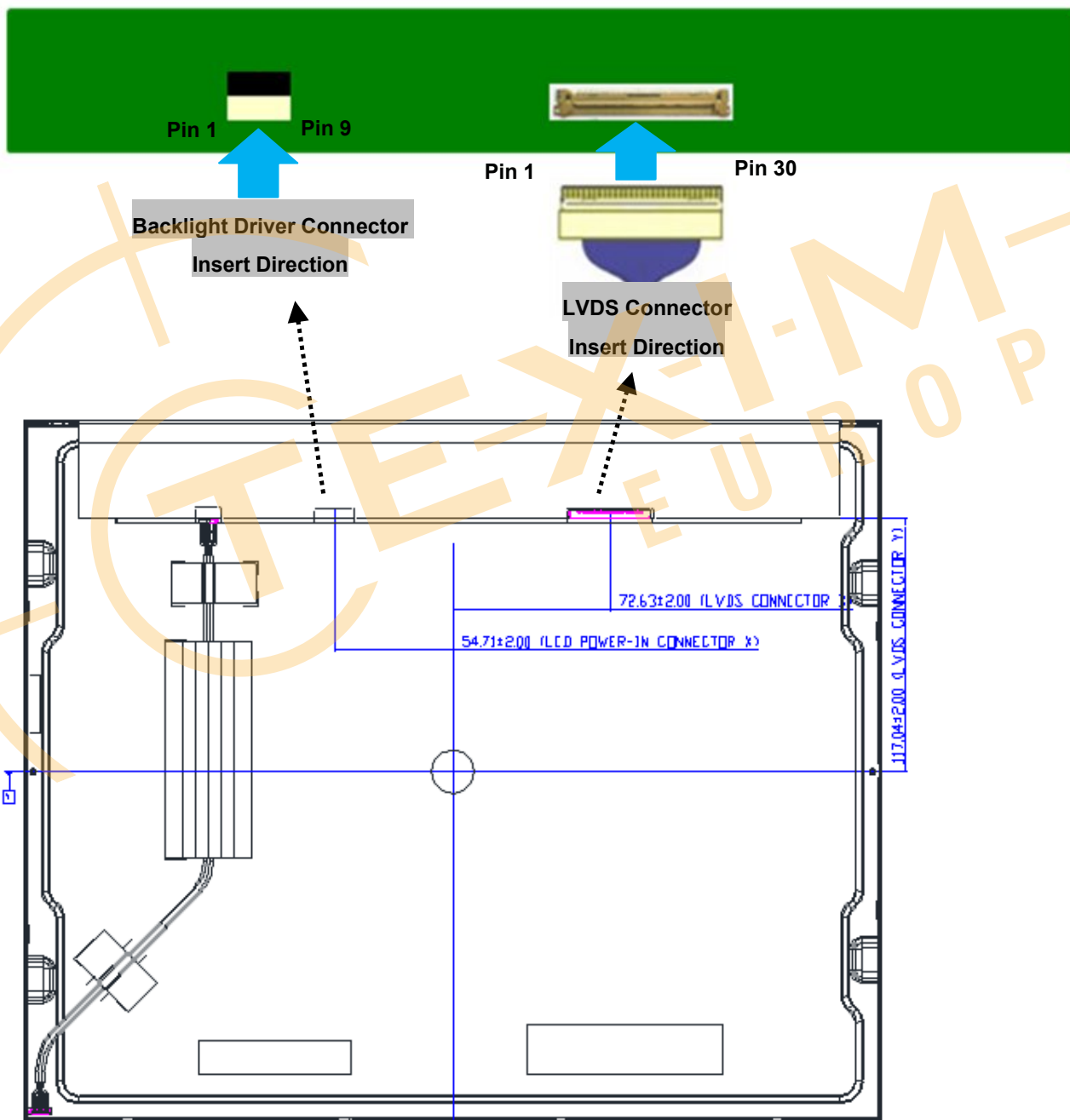



6.3 The Input Data Format

8 bits LVDS Input

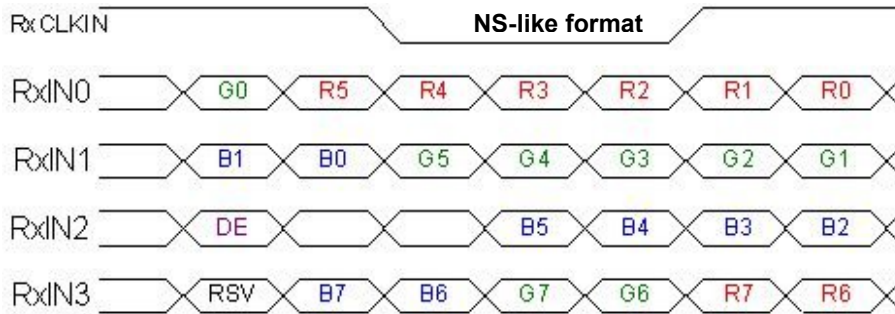

Note1: Please follow PSWG.

Note2: R/G/B data 7:MSB, R/G/B data 0:LSB

Signal Name	Description	Remark
R7	Red Data 7	Red-pixel Data
R6	Red Data 6	
R5	Red Data 5	For 8Bits LVDS input
R4	Red Data 4	MSB: R7 ; LSB: R0
R3	Red Data 3	
R2	Red Data 2	For 6Bits LVDS input
R1	Red Data 1	MSB: R5 ; LSB: R0
R0	Red Data 0	
G7	Green Data 7	Green-pixel Data
G6	Green Data 6	
G5	Green Data 5	For 8Bits LVDS input
G4	Green Data 4	MSB: G7 ; LSB: G0
G3	Green Data 3	
G2	Green Data 2	For 6Bits LVDS input
G1	Green Data 1	MSB: G5 ; LSB: G0
G0	Green Data 0	
B7	Blue Data 7	Blue-pixel Data
B6	Blue Data 6	
B5	Blue Data 5	For 8Bits LVDS input
B4	Blue Data 4	MSB: B7 ; LSB: B0
B3	Blue Data 3	
B2	Blue Data 2	For 6Bits LVDS input
B1	Blue Data 1	MSB: B5 ; LSB: B0
B0	Blue Data 0	
RxCLKIN	LVDS Data Clock	
DE	Data Enable Signal	When the signal is high, the pixel data shall be valid to be displayed.

Note: Output signals from any system shall be low or Hi-Z state when VDD is off.



6.4 Interface Timing

6.4.1 Timing Characteristics

Signal	Symbol	Min.	Typ.	Max.	Unit	
Clock Frequency	$1/T_{\text{Clock}}$	45	54	67.5	MHz	
Vertical Section	Period	T_V	1032	1066	1150	T_{Line}
	Active	T_{VD}	1024	1024	1024	
	Blanking	T_{VB}	8	42	126	
Horizontal Section	Period	T_H	780	844	2047	T_{Clock}
	Active	T_{HD}	540	640	640	
	Blanking	T_{HB}	140	204	-	
Frame Rate	F	49	60	76	Hz	

Note : DE mode.

6.4.2 Input Timing Diagram

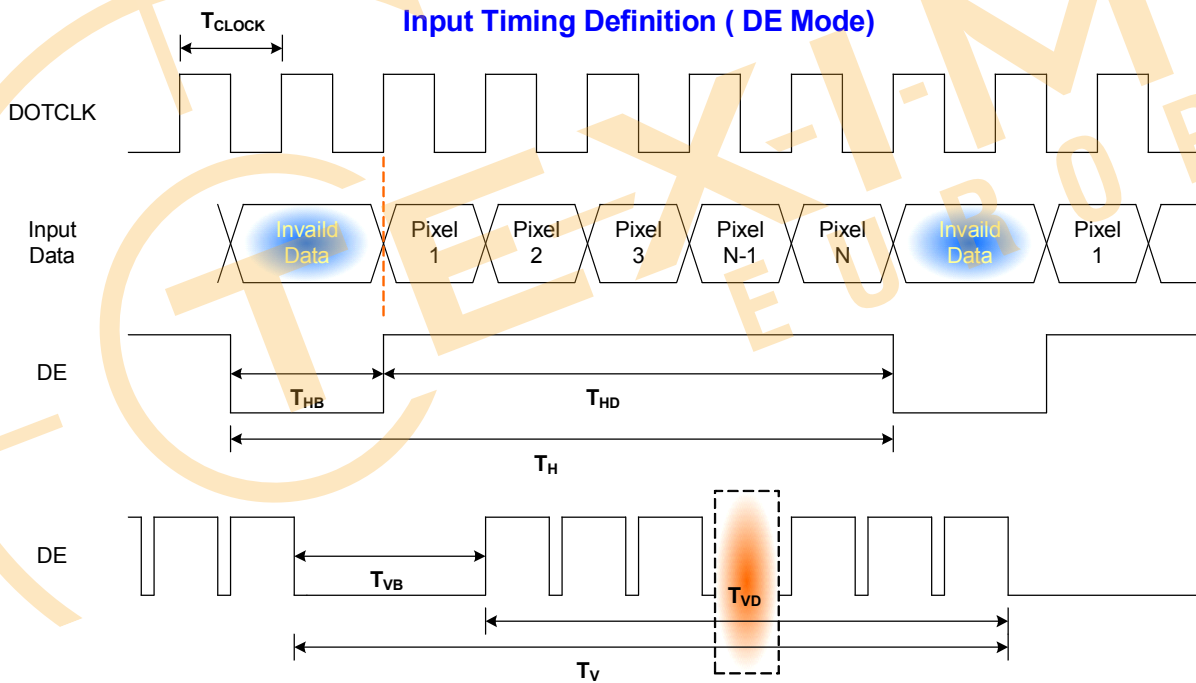



6.5 Power ON/OFF Sequence

VDD power and lamp on/off sequence is as below. Interface signals are also shown in the chart. Signals from any system shall be Hi-Z state or low level when VDD is off.

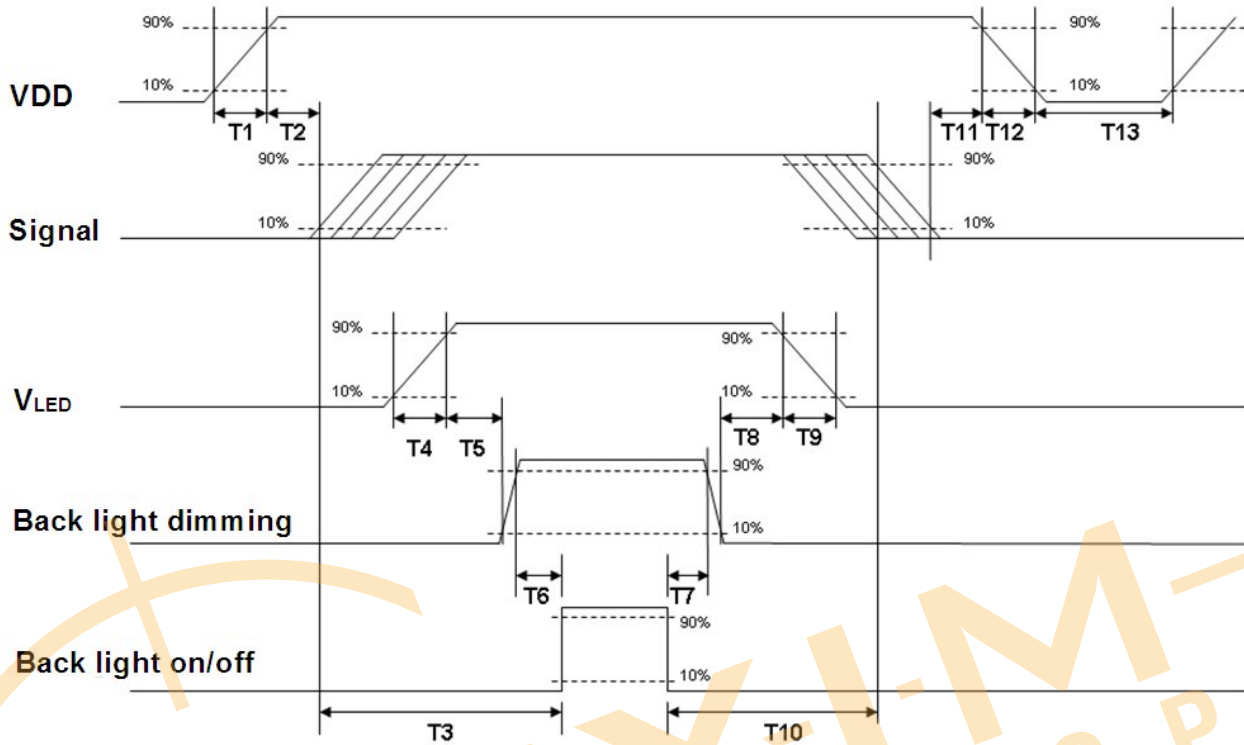

Power ON/OFF sequence timing

Parameter	Value			Units
	Min.	Typ.	Max.	
T1	0.5	-	10	[ms]
T2	30	40	50	[ms]
T3	200	-	-	[ms]
T4	0.5	-	10	[ms]
T5	10	-	-	[ms]
T6	10	-	-	[ms]
T7	0	-	-	[ms]
T8	10	-	-	[ms]
T9	-	-	10	[ms]
T10	110	-	-	[ms]
T11	0	16	50	[ms]
T12	-	-	10	[ms]
T13	1000	-	-	[ms]

The above on/off sequence should be applied to avoid abnormal function in the display. Please make sure to turn off the power when you plug the cable into the input connector or pull the cable out of the connector.



7. Reliability Test Criteria

Items	Required Condition	Note
Temperature Humidity Bias	50 °C /80%,300Hrs	Note 2
High Temperature Operation	70 °C, 300Hr (center point of panel surface)	Note 2
Low Temperature Operation	0 °C, 300Hr	Note 2
High Temperature Storage	70 °C, 300 hours	Note 2
Low Temperature Storage	-20 °C, 300 hours	Note 2
Thermal Shock Test	-20 °C /30 min ,60 °C /30 min ,100cycles, 40 °C minimum ramp rate	Note 2
Hot Start Test	70 °C storage 1 Hr. power on/off per 5 minutes, 5 times	
Cold Start Test	0 °C storage 1 Hr. power on/off per 5 minutes, 5 times	
Shock Test (Non-Operating)	50G,20ms,Half-sine wave,(±X, ±Y, ±Z)	
Vibration Test (Non-Operating)	1.5G, 10~200~10Hz, Sine wave 30mins/axis, 3 direction (X, Y, Z)	
On/off test	On/10 sec, Off/10 sec, 30,000 cycles	
ESD	Contact Discharge: ± 8KV, 150pF(330Ω) 1sec, 9 points, 25times/point, Class B Air Discharge: ± 15KV, 150pF(330Ω) 1sec 9 points, 25times/point, Class B	Note 1
EMI	30-230 MHz, limit 40 dBu V/m, 230-1000 MHz, limit 47 dBu V/m	
Altitude Test	Operation: 10,000ft Non-Operation: 30,000ft	

Note1:

According to EN61000-4-2 , ESD class B: Some performance degradation allowed. No data lost
Self-recoverable. No hardware failures.

Note2:

Water condensation is not allowed for each test items.

Each test is done by new TFT-LCD module. Don't use the same TFT-LCD module repeatedly for reliability test.

The reliability test is performed only to examine the TFT-LCD module capability.

To inspect TFT-LCD module after reliability test, please store it at room temperature and room humidity for 24 hours at least in advance.



Product Specification

G190EG02 V1 (V104)

AU OPTRONICS CORPORATION

8. Mechanical Characteristics

8.1 LCM Outline Dimension (Front View)

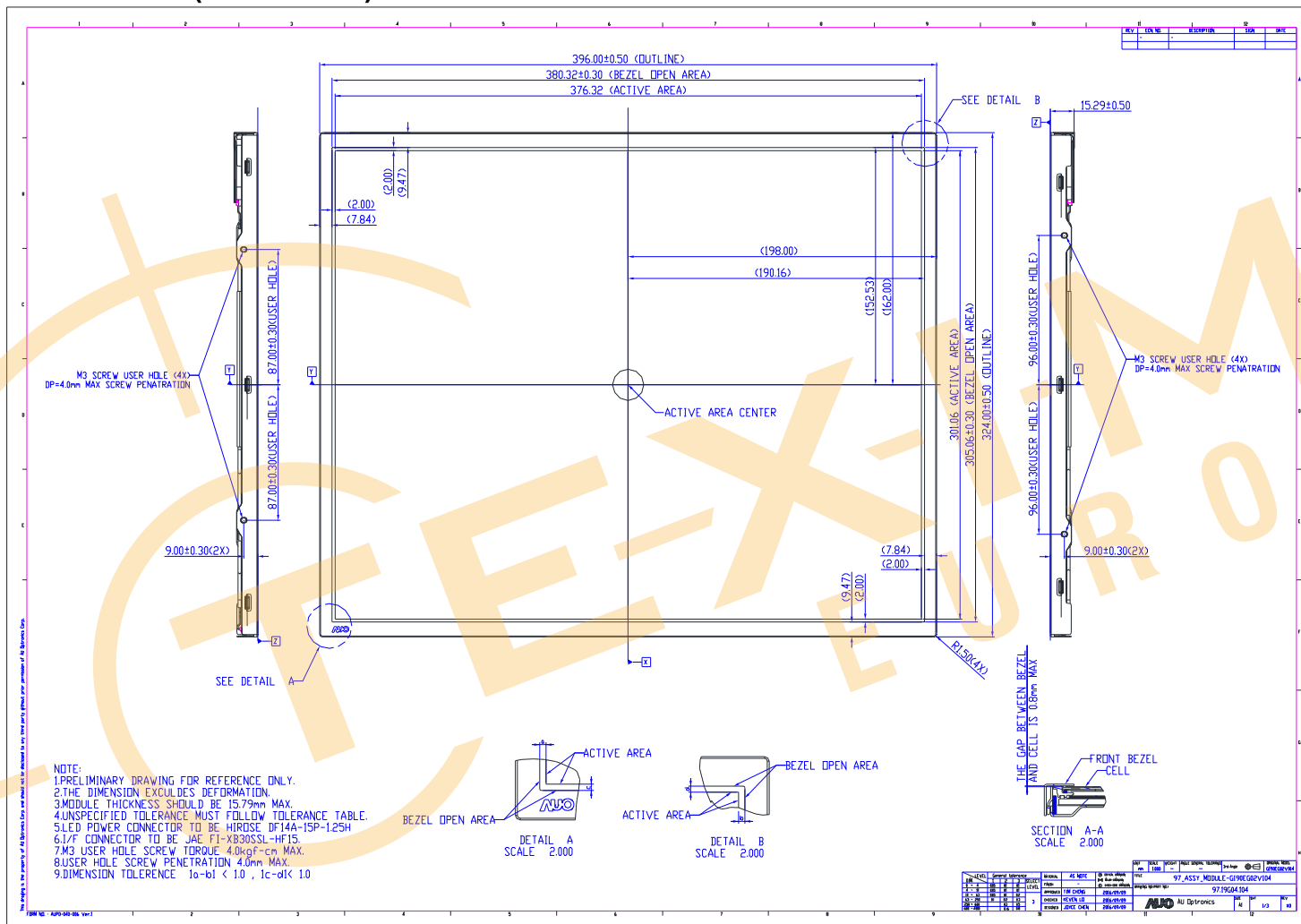



Product Specification

G190EG02 V1 (V104)

AU OPTRONICS CORPORATION

8.2 LCM Outline Dimension (Rear View)

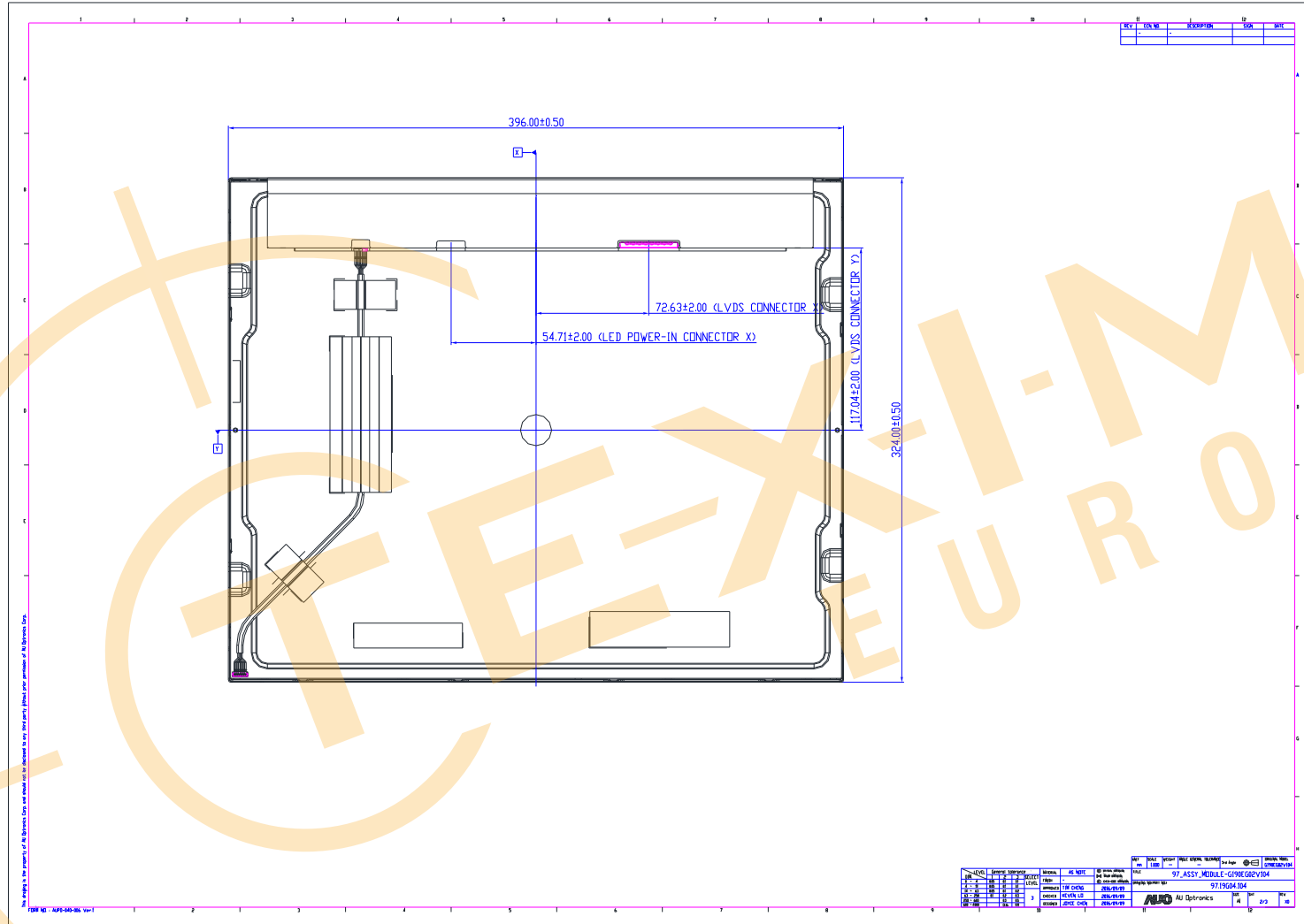



9. Label and Packaging

9.1 Shipping Label

The Label is on the rear side of TFT-LCD display as below:

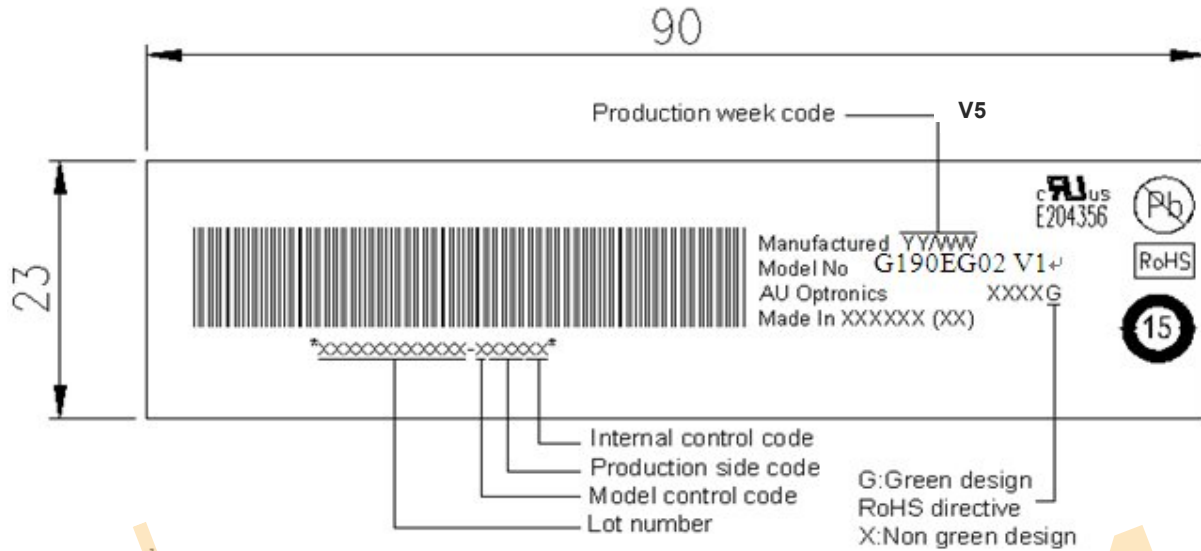

9.2 Carton Package

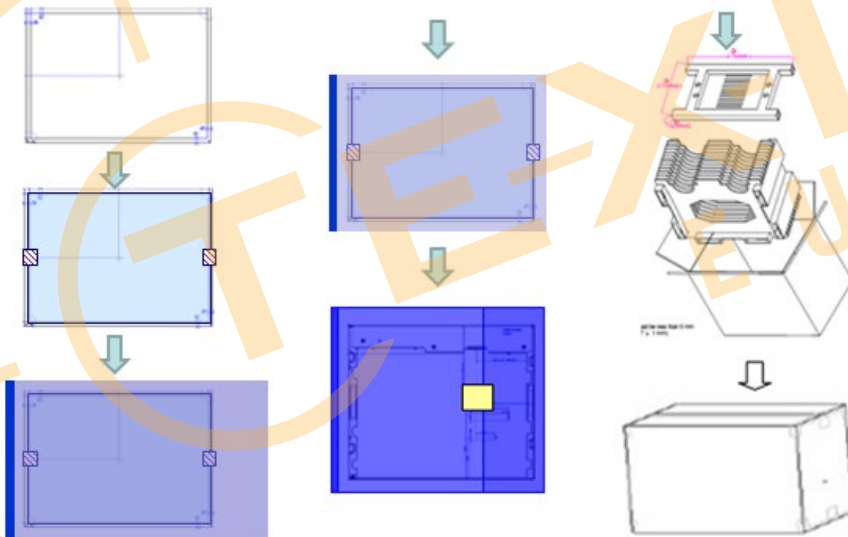

Max capacity : 8 TFT-LCD module per carton

Max weight: 17.0 kg per carton

Outside dimension of carton: 489mm(L)*293mm(W)*420mm(H)

Pallet size : 1140mm*1180mm*132mm

Box stacked

Module by air : (2*4)*3 layers, one pallet put 24 boxes, total 192pcs module

Module by sea : One pallet (2*4)*3 layers + One pallet (2*4)*1 layers, total 256pcs module

Module by sea_HQ : One pallet (2*4)*3 layers+ One pallet (2*4)*2 layers, total 320pcs module



10 Safety

10.1 Sharp Edge Requirements

There will be no sharp edges or comers on the display assembly that could cause injury.

10.2 Materials

10.2.1 Toxicity

There will be no carcinogenic materials used anywhere in the display module. If toxic materials are used, they will be reviewed and approved by the responsible AUO toxicologist.

10.2.2 Flammability

All components including electrical components that do not meet the flammability grade UL94-V1 in the module will complete the flammability rating exception approval process.

The printed circuit board will be made from material rated 94-V1 or better. The actual UL flammability rating will be printed on the printed circuit board.

10.3 Capacitors

If any polarized capacitors are used in the display assembly, provisions will be made to keep them from being inserted backwards.

10.4 National Test Lab Requirement

The display module will satisfy all requirements for compliance to:

UL 60950-1 second edition

U.S.A. Information Technology Equipment

Disclaimer

ALL PRODUCTS, PRODUCT SPECIFICATIONS AND DATA ARE SUBJECT TO CHANGE WITHOUT NOTICE TO IMPROVE RELIABILITY, FUNCTION OR DESIGN OR OTHERWISE.

Texim Europe B.V. its affiliates, agents, and employees, and all persons acting on its or their behalf (collectively, "Texim"), disclaim any and all liability for any errors, inaccuracies or incompleteness contained in any datasheet or in any other disclosure relating to any product.

Texim makes no warranty, representation or guarantee regarding the suitability of the products for any particular purpose or the continuing production of any product.

It is the customer's responsibility to validate that a particular product with the properties described in the product specification is suitable for use in a particular application.

Parameters provided in datasheets and / or specifications may vary in different applications and performance may vary over time.

All operating parameters, including typical parameters, must be validated for each customer application by the customer's technical experts.

Please contact us if you have any questions about the contents of the datasheet.

This may not be the latest version of the datasheet. Please check with us if a later version is available.

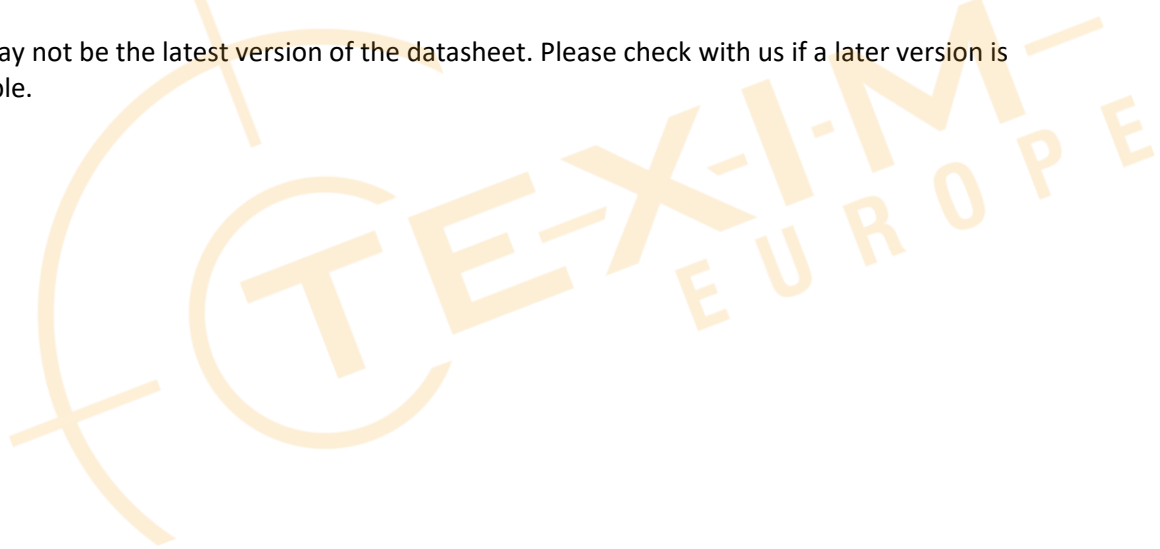



Headquarters & Warehouse

Elektrostraat 17
NL-7483 PG Haaksbergen
The Netherlands

T: +31 (0)53 573 33 33
E: info@texim-europe.com
Homepage: www.texim-europe.com



The Netherlands

Elektrostraat 17
NL-7483 PG Haaksbergen

T: +31 (0)53 573 33 33
E: nl@texim-europe.com



Belgium

Zuiderlaan 14, box 10
B-1731 Zellik

T: +32 (0)2 462 01 00
E: belgium@texim-europe.com



UK & Ireland

St Mary's House, Church Lane
Carlton Le Moorland
Lincoln LN5 9HS

T: +44 (0)1522 789 555
E: uk@texim-europe.com



Germany - North

Bahnhofstrasse 92
D-25451 Quickborn

T: +49 (0)4106 627 07-0
E: germany@texim-europe.com



Germany - South

Martin-Kollar-Strasse 9
D-81829 München

T: +49 (0)89 436 086-0
E: muenchen@texim-europe.com



Austria

Warwitzstrasse 9
A-5020 Salzburg

T: +43 (0)662 216 026
E: austria@texim-europe.com



Nordic

Søndre Jagtvej 12
DK-2970 Hørsholm

T: +45 88 20 26 30
E: nordic@texim-europe.com



Italy

Martin-Kollar-Strasse 9
D-81829 München

T: +49 (0)89 436 086-0
E: italy@texim-europe.com