

GYPRO®4300 – High stability $\pm 300^\circ/s$ closed-loop MEMS gyroscope with digital interface

Key Performances

- $\pm 300^\circ/s$ input range single-axis gyro
- Bias instability: $0.4^\circ/h$ (90 % of production $< 1^\circ/h$)
- Angular Random Walk: $0.07^\circ/\sqrt{h}$
- Residual scale factor error over temperature range: 160 ppm
- Vibration rectification error: $0.5^\circ/h/g^2$
- Bandwidth: 200 Hz (customizable upon request)
- Latency: 1 ms
- Start-up time: 1 s
- Available in 3 resonant frequency configurations to minimize mechanical cross-coupling in multi-axis applications.

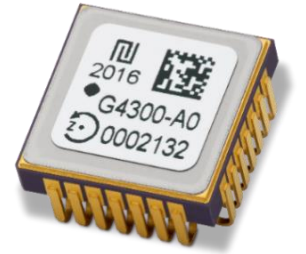

Key Features

- 24-bit digital SPI interface
- Initial and continuous self-test
- Factory-calibrated over temperature
- Hermetic ceramic SMD 28 pins J-LEAD package
- Non classified under dual-use export control
- REACH and RoHS compliant

Distributed by:



Applications

- IMU (Inertial Measurement Unit) for precision robotics and remotely operated vehicles
- INS (Inertial Navigation System) for GNSS-assisted positioning and navigation of trains, air and land transportation systems
- AHRS (Attitude & Heading Reference System)
- MRU (Motion Reference Units)
- Stabilization systems

General Description

GYPRO®4300 is a single-axis, high performance, closed-loop MEMS gyro with a $\pm 300^\circ/s$ input range that offers a digital, affordable, and low-SWaP alternative to entry-level fiber optical gyros (FOG). GYPRO®4300 is perfectly suited to precision attitude, guidance, motion control and GNSS-aided positioning and navigation applications in demanding industrial, land, railway, marine, oil and gas and energy environments.

The 24-bit digital SPI interface eases the integration of GYPRO®4300 into high performance IMU and INS, while the built-in self-test ensures initial verification of the sensor's integrity and continuous in-operation functionality test.

GYPRO®4300 is free from dual-use export control as well as REACH and RoHS compliant. It is ideally complemented by AXO® high performance digital accelerometers to enable multi-axis high performance inertial systems.

AXO® & GYPRO® products sensors are factory calibrated and compensated for temperature effects to provide high-accuracy digital output over a broad temperature range. Raw data output can be also chosen to enable customer-made compensations.

Disclaimer

Information furnished by Tronics is believed to be accurate and reliable. However, no responsibility is assumed by Tronics for its use, nor for any infringements of patents or other rights of third parties that may result from its use.

Specification subject to change without notice.

No license is granted by implication or otherwise under any patent or patent rights of Tronics. Trademarks and registered trademarks are the property of their respective owner.

Contents

Block diagram	3
Overall Dimensions	3
1. Specifications	4
2. Absolute maximum Ratings	6
3. Typical performances	7
4. Interface	9
4.1. Pinout, sensitive axis identification	9
4.2. Application circuit	9
4.3. Input/Output Pin Definitions	10
5. Recommendations	11
5.1. Soldering	11
5.2. Multi-axis application	11
6. Digital SPI interface	12
6.1. Electrical and Timing Characteristics	12
6.2. SPI frames description	13
6.3. Angular rate readings	13
6.3.1. Angular rate (RATE) output	13
6.3.2. Data Ready (DRY) bit	13
6.3.3. Self-Test (ST) bit	13
6.4. Temperature readings	13
6.5. Advanced use of SPI registers	14
6.5.1. R/W access to the System Registers	14
6.5.2. R/W access to the MTP	14
6.5.3. Useful Sensor Parameters	15
6.6. Modification of the data rate	16
7. Angular rate calibration procedure	17
7.1. Algorithm overview	17
7.1.1. Angular rate output calibration model	17
7.1.2. Recommended procedure	17
7.2. Programming of the new coefficients	18
7.2.1. Checking the MTP slot status	18
7.2.2. Programming the coefficients	18
7.2.3. Updating MTP slot status	18
7.3. Switch to uncompensated data output	19
8. Temperature Sensor Calibration Procedure	20
8.1. Temperature sensor calibration model	20
8.2. Recommended Procedure	20
9. Device Identification / Ordering information	21
9.1. Device identification	21
9.2. Ordering information	21
10. Internal construction and Theory of Operation	22
11. Available Tools and Resources	23
12. Revision History	24

Block diagram

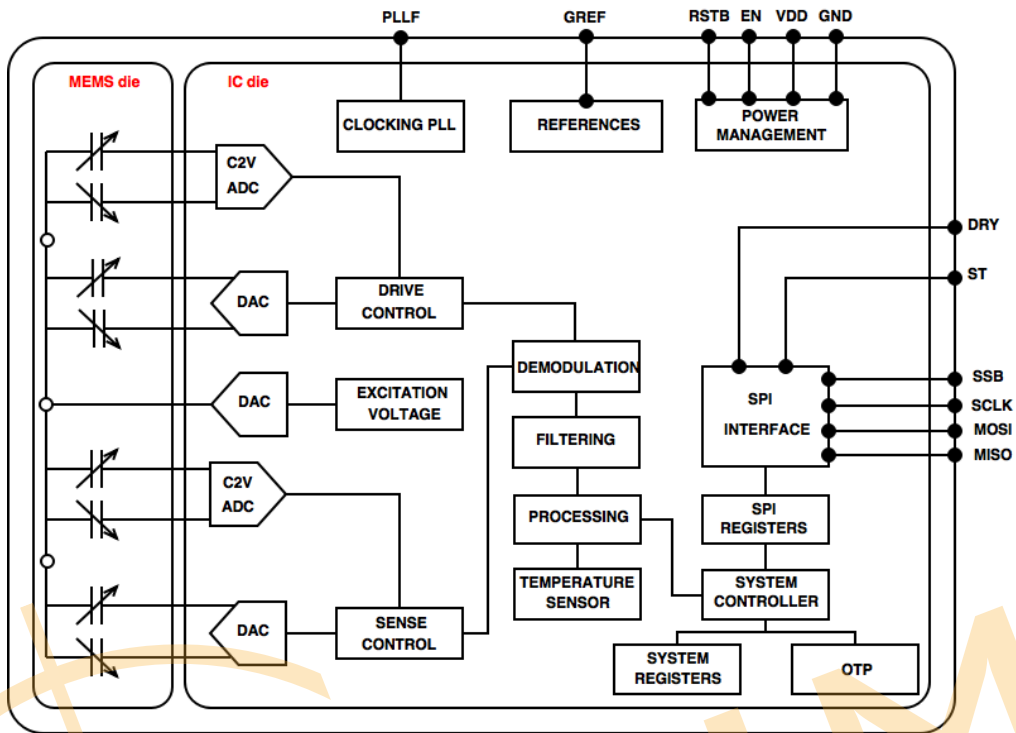

Overall Dimensions

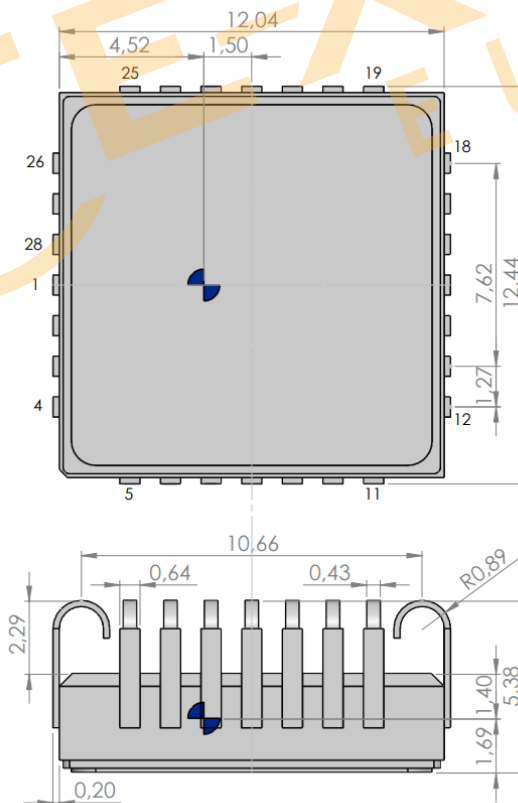

1. Specifications

Parameter	Unit	Min	Nom	Max ⁽²⁾	Notes
Measurement Ranges					
Input range ⁽¹⁾	°/s		±300		Electronic clamping is applied and sensors will saturate before ±500°/s.
Temperature range ⁽¹⁾	°C	-40		+85	
Bias					
Bias instability ⁽¹⁾	°/h		0.4	2	Lowest point of Allan variance curve at room temperature. 90 % of production < 1 °/h.
Bias in-run (short term) stability	°/h		7		Standard deviation of the 1 second filtered output over 1 hour at room temperature, after 30 min of stabilization.
Residual Bias Temperature Error (1σ), calibrated ⁽¹⁾	°/h		40		Standard deviation of the bias over the specified temperature range. Factory calibration is performed in test socket. As printed circuit board reflow soldering may cause shifts in bias temperature variations, it may be necessary to do an on-board calibration after soldering, depending on applications requirements.
Bias run to run repeatability	°/h		10		Standard deviation of 7 bias measurements at 30°C that occurs between seven runs of operation with 30 minutes power off between each run.
Vibration rectification coefficient	°/h/g ²		0.5		Bias rectification under operating vibration, overall level 7.3 g rms, test condition B, method 2026, MIL-STD-883F.
Scale Factor					
Scale factor ⁽¹⁾	LSB/°/s		10 000		Nominal scale factor.
Residual scale factor Temperature Error (1σ), calibrated ⁽¹⁾	ppm		160		Standard deviation of the scale factor over the specified temperature range.
Scale factor run to run repeatability	ppm		60		Standard deviation of 7 scale factor measurements at 30°C that occurs between seven runs of operation with 30 minutes power off between each run.
Scale Factor nonlinearity ⁽¹⁾	ppm		60		Maximum deviation of the output from the expected value using a best fit straight line, at room temperature.
Noise					
RMS Noise ⁽¹⁾	°/s		0.015	0.05	RMS noise level in the band [1-100Hz], obtained by integrating the power spectral density of the sensor output between 1 and 100Hz at zero rate and room temperature.
Angular random walk ⁽¹⁾	°/√h		0.07		-1/2 slope of Allan variance curve at room temperature.
Frequency response					
Bandwidth	Hz		>200Hz		Defined as the frequency for which attenuation is equal to -3dB.
Data Rate	Hz	1600		2000	Refresh rate of the output data at room temperature.

Parameter	Unit	Min	Nom	Max ⁽²⁾	Notes
Latency	ms		1		Time interval between the implementation of a rate signal on the input and the availability of the corresponding data on the output.
Start-up Time ⁽³⁾	s		1		Time interval between application of power on and the availability of an output signal (at least 90% of the input rate), at room temperature.
Linear acceleration					
G sensitivity	°/h/g		10		Mean value on all axis of output variation under 1 g.
Axis alignment					
Rate axis misalignment	mrad			20	Misalignment between the sensitive axis and the normal to the package bottom plane, by design.
Environmental					
Device Weight	gram		1.5		
Storage temperature range	°C	-55		+125	
Humidity at 45°C	%			98	
Moisture Sensitivity Level (MSL)	--		1		Unlimited floor life out of the bag (hermetic package).
Shock (operating)	g ms		50 6		Half sine.
Shock (survival)	g ms		2000 0.3		
Vibrations (operating)	g _{rms}		7.3		test condition B, method 2026, MIL-STD-883F.
Vibrations (survival)	g _{rms}		20		
Electrical					
Power Supply Voltage	V	4.75	5.00	5.25	
Current consumption (normal mode)	mA		25		
Current consumption (power down mode)	µA		1	5	Power down mode is activated by switching EN pin to GND.
Power supply rejection ratio	°/h/V		20		
Temperature sensor					
Scale Factor (raw data)	LSB/°C		85		Temperature sensor is not factory-calibrated.
25°C typical output (raw data)	LSB		8000		Temperature sensor is not factory-calibrated.
Refresh rate	Hz		6		
Reliability					
MTBF	hours		≥ 1000 000		Predictive elapsed time between inherent failures of the sensor during normal system operation for 50°C use temperature

Table 1: Specifications

⁽¹⁾ 100% tested in production.

⁽²⁾ Unless otherwise specified, max values are ±3 sigma variation limits from validation test population.

⁽³⁾ Startup guaranteed at -20°C. Applications requiring start at temperature below -20°C require dedicated integration constraints and/or specific product configuration. Please contact us for more information.

2. Absolute maximum Ratings

Stresses at or exceeding the maximum ratings listed below may cause permanent damage to the device, or affect its reliability. Exposure to maximum ratings conditions for extended periods may also affect device reliability.

Functional operation is not guaranteed once stresses exceeding the maximum ratings have been applied.

Parameter	Unit	Min	Max
Supply Voltage	V	-0.5	+7
Electrostatic Discharge (ESD) protection, any pin, Human Body Model	kV	--	±2
Storage temperature range	°C	-55	+125
Shock survival	g	--	2000
Vibrations survival, 20-2000Hz	g _{rms}	--	20
Ultrasonic cleaning		Not allowed	

Table 2: Maximum ratings

Caution!



The product may be damaged by ESD, which can cause performance degradation or device failure! We recommend handling the device only on a static safe work station. Precaution for the storage should also be taken.



The sensor **MUST** be powered-on *before* any SPI operation, as shown in Figure 1 below. Having the SPI pads, VDDIO or EN at a high level while VDD is at a low level could damage the sensor, due to ESD protection diodes and buffers.



Sensor product stresses at or above those listed under Table 2 Maximum ratings, may cause permanent damage and may affect product reliability

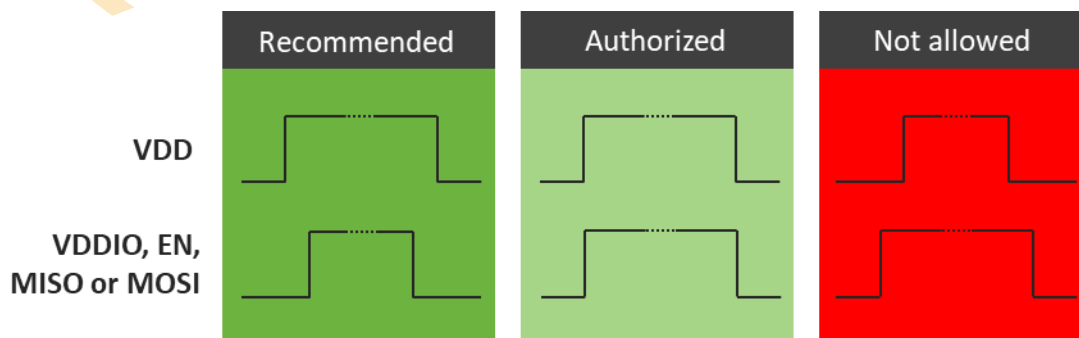

Figure 1: Recommended voltage sequence

3. Typical performances

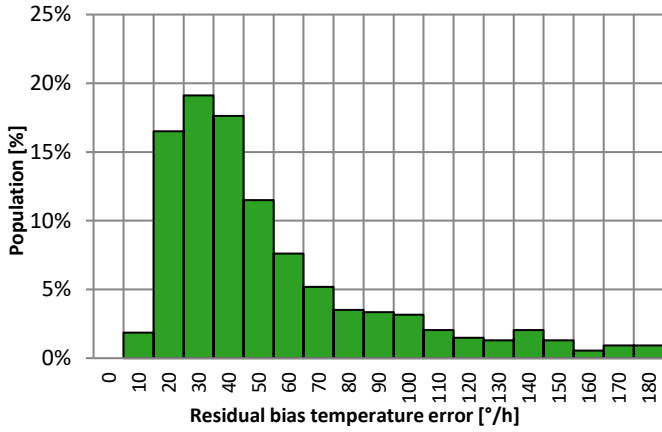

Figure 2: Distribution of bias over temperature

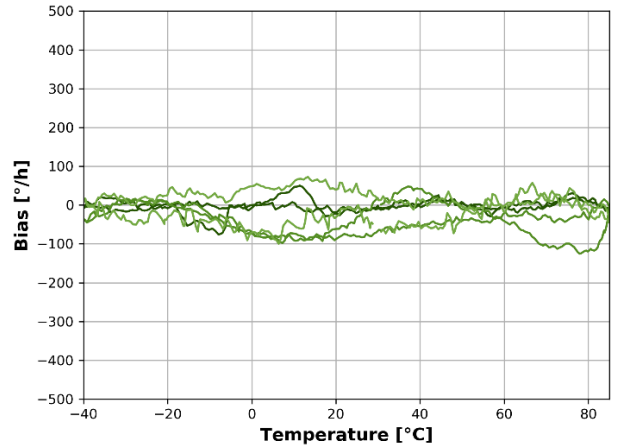

Figure 5: Residual bias temperature error (3 samples)

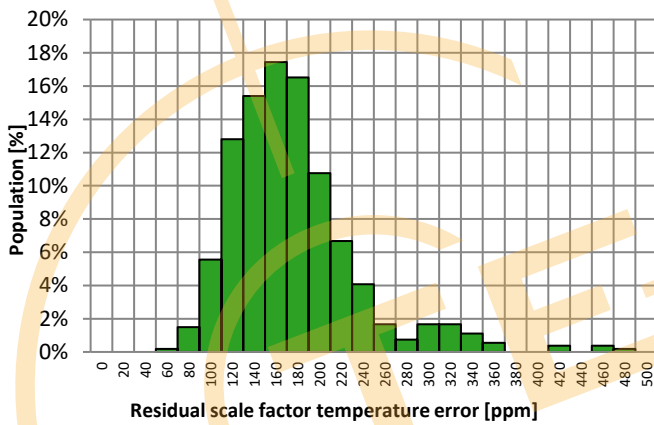

Figure 3: Distribution of scale factor over temperature

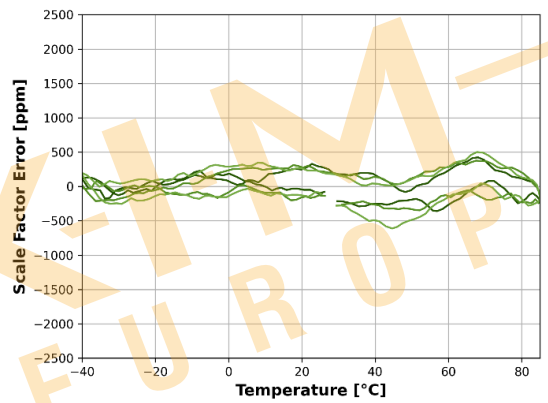

Figure 6: Residual scale factor error (3 samples)

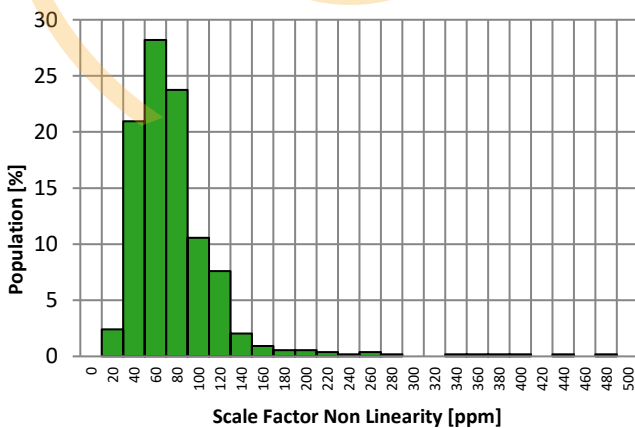

Figure 4: Distribution of scale factor non linearity

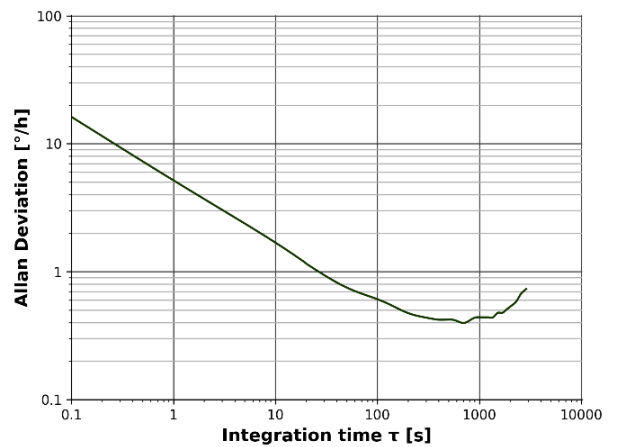

Figure 7: Allan variance (at 35°C)

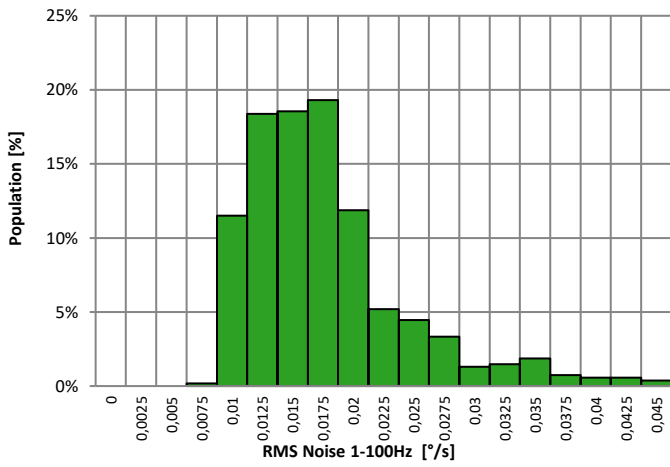

Figure 8: Distribution of RMS Noise in [1 -100Hz] band

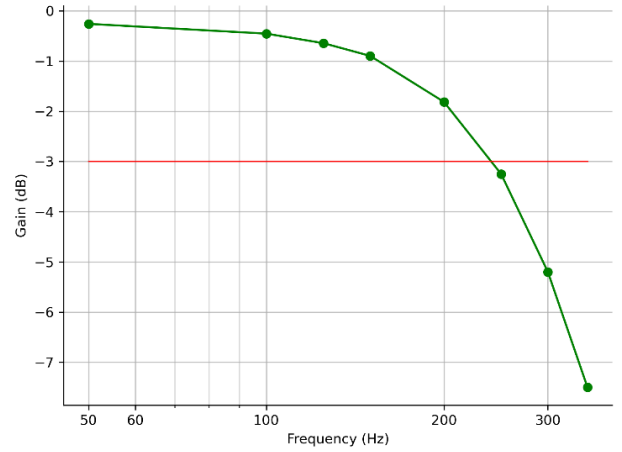

Figure 10: Frequency response (room temperature)

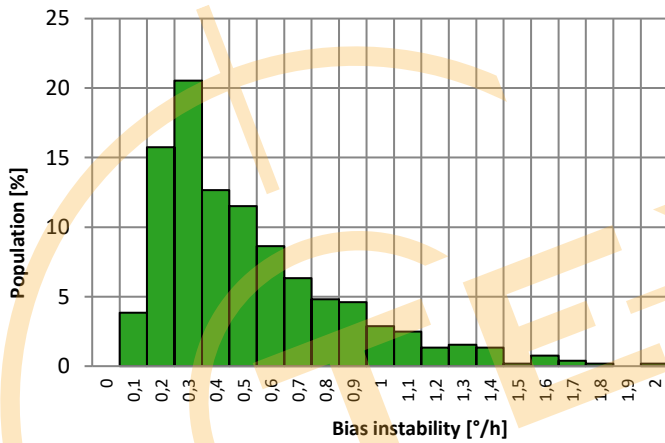

Figure 9: Distribution of Bias instability

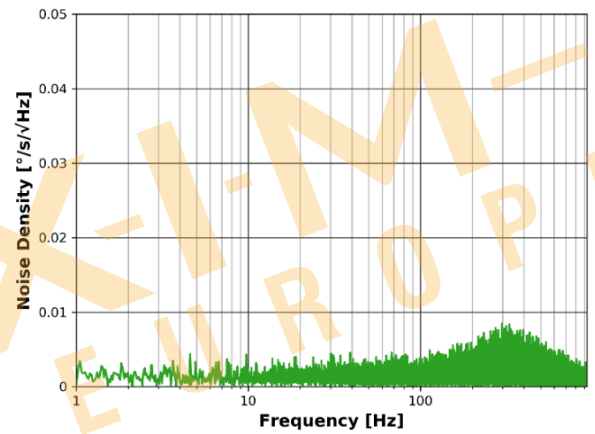

Figure 11: Noise density (room temperature)

4. Interface

4.1. Pinout, sensitive axis identification

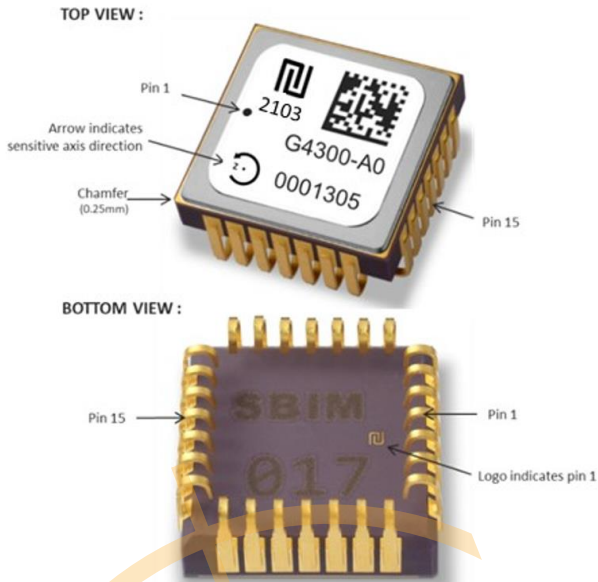

Figure 12: How to locate Pin 1

4.2. Application circuit

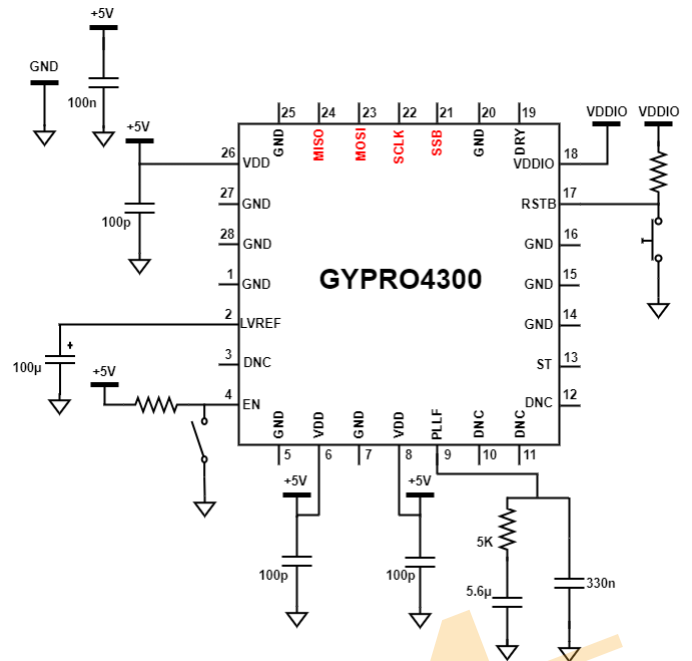

Figure 14: Recommended Application Schematic (top view)

Notes:

- All capacitances of Figure 14 should be placed as close as possible to their corresponding pins, except the 100nF capacitance between VDD and GND, which should be as close as possible to the board's supply input.
- The 100µF filtering capacitance between LVREF and GND should have low Equivalent Series Resistance (ESR < 1Ω) and low leakage current (< 6µA). A tantalum capacitor is recommended.
- 5.6µF and 330nF filtering capacitance between PLLF and GND should have a low leakage current (< 1µA).
- The digital pads maximum ratings are GND-0.3V and VDD+0.3V.

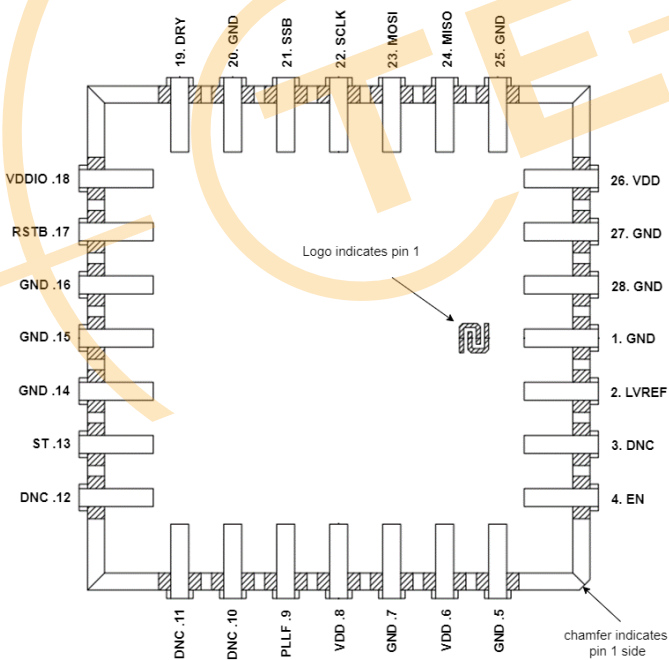

Figure 13: GYPRO4300 Sensors Pinout (bottom view)

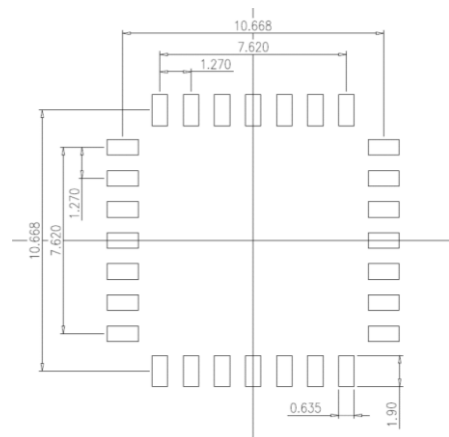

Figure 15: Recommended Pad Layout in mm (top view)

4.3. Input/Output Pin Definitions

Pin name	Pin number	Pin type	Pin direction	Pin levels	Function
GND	1, 5, 7, 14, 15, 16, 20, 25, 27,28	Supply	n/a	0V	Power Ground
VDD	6, 8, 26	Supply	n/a	+5V	Power Supply
MISO	24	Digital	Output	VDDIO	Master Input Slave Output signal
MOSI	23	Digital	Input	VDDIO	Master Output Slave Input signal
SCLK	22	Digital	Input	VDDIO	SPI clock signal
SSB	21	Digital	Input	VDDIO	Slave Selection signal. Active low
DRY	19	Digital	Output	VDDIO	Data Ready flag. Generates a pulse when a new angular rate data is available.
VDDIO	18	Supply	n/a	+1.8V to +5V	Reference voltage for the SPI signals and DRY, RSTB wires.
RSTB	17	Digital	Input	VDDIO with pull-up of 100kΩ	Reset. Reloads the internal calibration data. Active low
ST	13	Digital	Output	+5V	Self-test status. Logic "1" when the sensor is OK.
PLLF	9	Analog	Output	0.8V	External filtering pad. MUST be connected to a filtering stage, described in Figure 14.
EN	4	Digital	Input	+5V with pull up of 100kΩ	Enable command. Active high.
LVREF	2	Analog	n/a	4.4V	External decoupling pad. MUST be connected to the board's GND through a 100μF external capacitor, in order to ensure low noise.
DNC	3, 10, 11, 12	--	--	--	Do Not electrically Connect. These pins provide additional mechanical fixing to the board and should be soldered to an unconnected pad.

Table 3: Pin Functions

5. Recommendations

5.1. Soldering

Please note that the reflow profile to be used does not depend only on the sensor. The whole populated board characteristics shall be considered.

MEMS components are sensitive to mechanical stress coming from the Printed Circuit Board (PCB) during the soldering reflow. In order to achieve the best performance, it is recommended to do an on-board calibration after the soldering of the sensor.

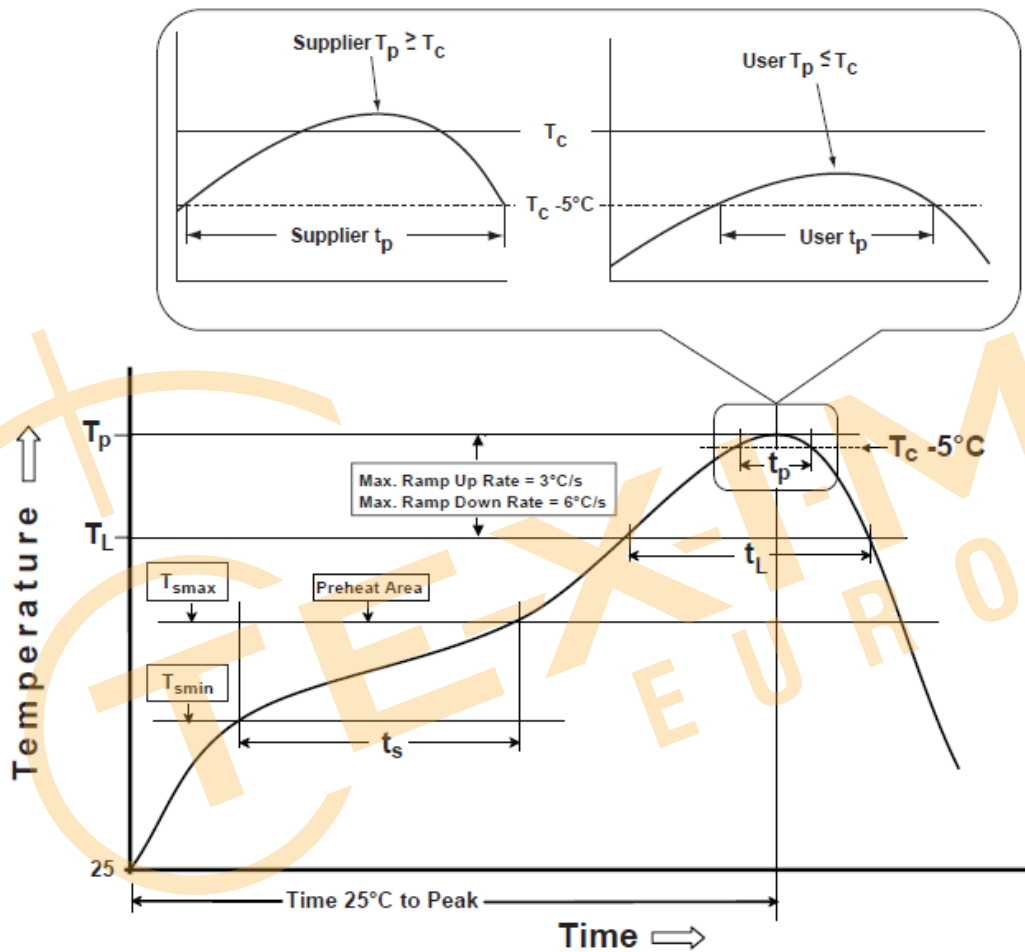

Figure 16: Reflow Profile, according to IPC/JEDEC J-STD-020D.1

Profile Feature	Eutectic Assembly
Time maintained above Temperature (T_L)	183°C
Time (t_L)	60-150 sec
Peak Temperature (T_p)	240°C (+/-5°C)
Time within 5°C of Actual Peak Temperature (t_p)	10-30 sec

Table 4: Reflow Profile Details, according to IPC/JEDEC J-STD-020D.1

5.2. Multi-axis application

In order to minimize the effects of mechanical cross-coupling when several devices are mounted into a multi-axis system (IMU, INS, MRU...), the GYPRO®4300 is available in 3 frequency configurations (low/mid/high). Refer to section 9 for more information.

6. Digital SPI interface

6.1. Electrical and Timing Characteristics

The device acts as a slave supporting only SPI "mode 0" (clock polarity CPOL=0, clock phase CPHA=0).

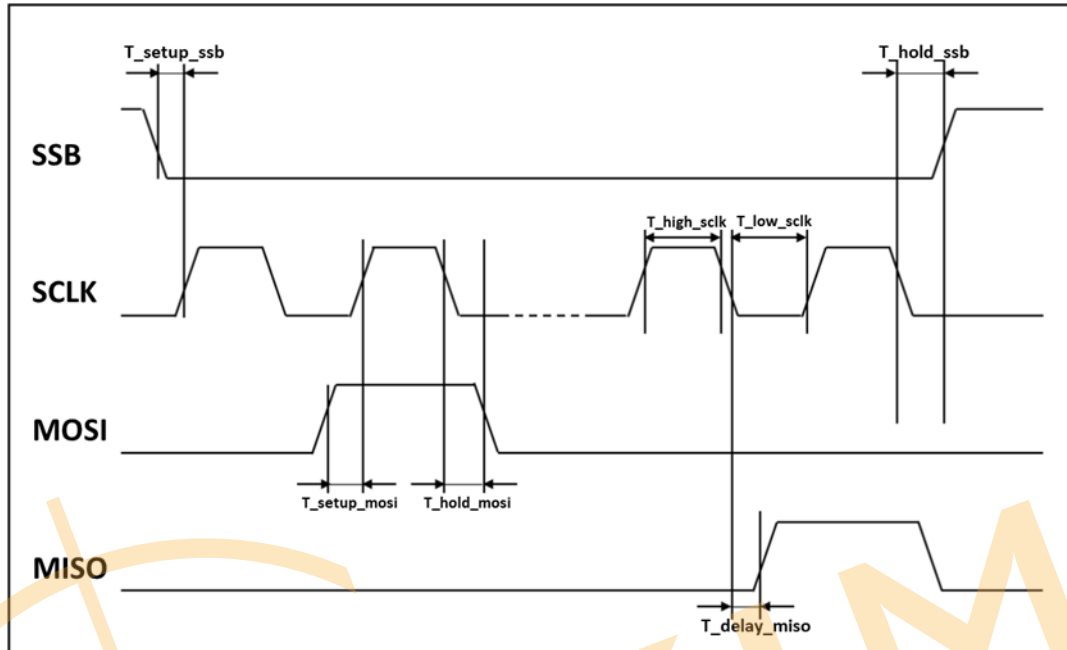

Figure 17: SPI timing diagram

Symbol	Parameter	Condition	Unit	Min	Typ	Max
Electrical characteristics						
VIL	Low level input voltage		VDDIO	0		0.1
VIH	High level input voltage		VDDIO	0.8		1
VOL	Low level output voltage	ioL=0mA (Capacitive Load)	V		GND	
VOH	High level output voltage	ioH=0mA (Capacitive Load)	V		VDDIO	
Rpull_up	Pull-up resistor	Internal pull-up resistance to VDD	kΩ		100	
Rpull_down	Pull-down resistor	Internal pull-down resistance to GND	kΩ		-	
Timing parameters						
Fspi	SPI clock input frequency	Maximal load 25pF on MOSI or MISO	MHz		0.2	8
T_low_sclk	SCLK low pulse		ns	62.5		
T_high_sclk	SCLK high pulse		ns	62.5		
T_setup_mosi	MOSI setup time		ns	10		
T_hold_mosi	MOSI hold time		ns	5		
T_delay_miso	MISO output delay	Load 25pF	ns			40
T_setup_ssb	SSB setup time		Tsclk	1		
T_hold_ssb	SSB hold time		Tsclk	1		

Table 5: SPI timing parameters

The MISO pin is kept in high impedance when the SSB level is high, which allows sharing the SPI bus with other components.

IMPORTANT NOTE: It is forbidden to keep SPI pads at a high level while VDD is at 0V due to ESD protection diodes and buffers.

6.2. SPI frames description

The SPI frames used for the communication through the SPI Register are composed of an instruction followed by arguments. The SPI instruction is composed of 1 byte, and the arguments are composed of 2, 4 or 8 bytes, depending on the cases, as can be seen in Table 6 below.



Figure 18: SPI Message Structure

Instruction	Argument	Meaning
0x50	0x00000000 (n=4)	Read Angular Rate
0x54	0x0000 (n=2)	Read Temperature
0x58	0x00000000 (n=4)	Advanced commands.
0x78	0xFFFFXXXX (n=8)	See Section 6.5 for more details.
0x7C	0xFFFF (n=2)	

Table 6: Authorized SPI commands

6.3. Angular rate readings

From the 32-bits (4 bytes) frame obtained after the "Read Angular Rate" instruction, the 24-bits word of angular rate data (RATE) must be extracted as shown below in Figure 19.

DRY and ST are respectively the "data ready" and "self-test" bits, also directly available on Pins 19 and 13.

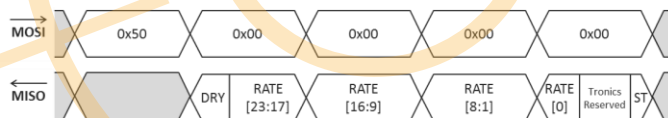

Figure 19: Angular rate reading frames and data organization

6.3.1. Angular rate (RATE) output

The 24-bit gyro output is coded in two's complement (Table 7).

- If the temperature compensation is not enabled (GOUT_SEL=0), then the user should perform scale factor measurements.
- If the temperature compensation of the angular rate output is enabled (default case), dividing the 24-bit value by a factor 10 000 results in the angular rate in °/s, as shown in Table 7.

-450.0000	°/s	↔	1011 1011 0101 0101 1110 0000
...			
-300.0000	°/s	↔	1101 0010 0011 1001 0100 0000
...			
-0.0002	°/s	↔	1111 1111 1111 1111 1111 1110
-0.0001	°/s	↔	1111 1111 1111 1111 1111 1111
0.0000	°/s	↔	0000 0000 0000 0000 0000 0000
+0.0001	°/s	↔	0000 0000 0000 0000 0000 0001
+0.0002	°/s	↔	0000 0000 0000 0000 0000 0010
...			
+300.0000	°/s	↔	0010 1101 1100 0110 1100 0000
...			
+450.0000	°/s	↔	0100 0100 1010 1010 0010 0000

Table 7: Conversion table for calibrated angular rate output

6.3.2. Data Ready (DRY) bit

The Data Ready bit is a flag which is raised when a new angular rate data is available. The flag stays raised until the new data is read.

Similarly to the Data Ready pin, the Data Ready bit signal can be used as an interrupt signal to optimize the delays between newly available data and their readings.

6.3.3. Self-Test (ST) bit

GYPRO provides both an initial self-test, done during the sensor start-up to check the ASIC digital blocks integrity, and a continuous self-test in operation. The continuous self-test checks the integrity of the SPI communication as well as the closed-loop operation.

The self-test procedure is running in parallel with the main functions of the sensor. The self-test status is available at the same time as the sensor output to indicate whether the sensor is properly operating (drive loop and sense loop control). The ST data is also available on the pin 13.

6.4. Temperature readings

The temperature data is an unsigned integer, 14-bits word (TEMP). It must be extracted from the 2 bytes of read data, as shown below in Figure 20.

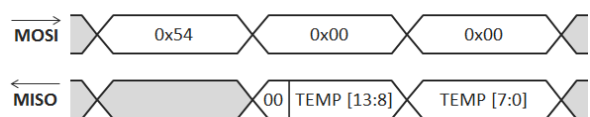

Figure 20: Temperature reading frames and data organization

By default, the temperature sensor is *not* factory calibrated (TOUTSEL=0).

GYPRO4300 Datasheet

6.5. Advanced use of SPI registers

SPI registers can also be used to access the System register or the MTP (Multi-Time-Programmable memory) by writing the corresponding SPI command. The following subsections (6.5.1. and 6.5.2.) describe the detailed processes to access them by read and write command.

6.5.1. R/W access to the System Registers

IMPORTANT NOTE: Modifications to the system registers are reversible. Modified registers will *not* be restored after a RESET. There is no limitation to the number of times the system registers can be modified.

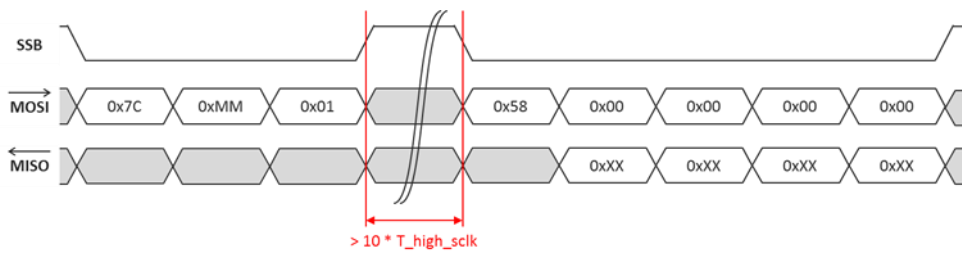

Figure 21: Sequence of instructions to READ address 0xMM of the system registers

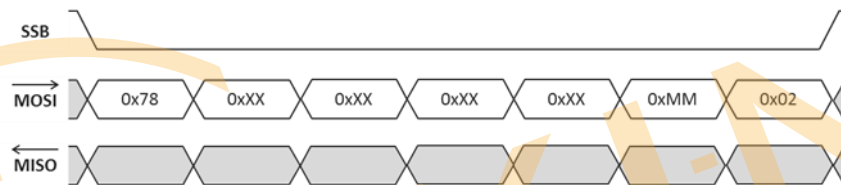

Figure 22: Sequence of instructions to WRITE '0XXXXXXXX' to address '0xMM' of the system registers

6.5.2. R/W access to the MTP

IMPORTANT NOTE: Modifications to the MTP are non-reversible. Modified parameters will be restored, even after a RESET, and previous values of the MTP cannot be accessed anymore. The maximum number of times the MTP can be written depends on the address:

- 5 times for the angular rate calibration coefficients (see Section 7 for more details)
- Only 1 time for all the other coefficients, including the temperature sensor calibration coefficients.

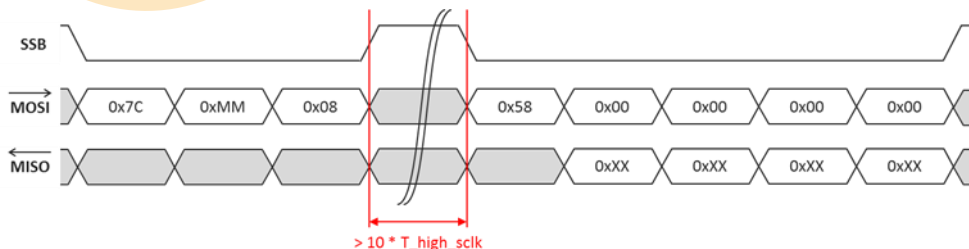

Figure 23: Sequence of instructions to READ address 0xMM of the MTP

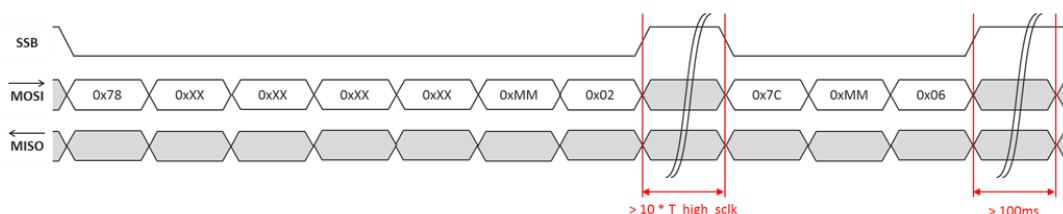

Figure 24: Sequence of instructions to WRITE data '0XXXXXXXX' to address '0xMM' of the MTP

6.5.3. Useful Sensor Parameters

The instructions given in Sections 6.5.1 and 6.5.2 can be used to read and/or to modify the sensor's useful parameters given in Table 8 below.

Parameter	Address M (System Register & MTP)	Bits	Encoding	Meaning
Sensor Identification				
UID	0x03	[31:0]	Tronics reserved	Sensor 'Unique Identification' number
Modification of data rate				
ODRSEL	0x3D	[7:2]	Binary 0b001111**	From minimum value of 0 [0b000000] to maximum value of 49 [0b110001] - See section 6.6
Temperature output compensation				
TOUT_SEL	0x04	3 ⁽¹⁾	0 ⁽²⁾ 1	Disable the calibrated temperature output Enable the calibrated temperature output
O	0x04	[31:18] ⁽¹⁾	0x0000 ⁽²⁾ See section 8	Offset calibration of temperature sensor
G	0x04	[17:4] ⁽¹⁾	0x0800 ⁽²⁾ See section 8	Gain calibration of temperature sensor
Angular rate output compensation				
GOUT_SEL	0x3D	31 ⁽¹⁾	0 1 ⁽²⁾	Disable the calibrated angular rate output Enable the calibrated angular rate output
MTPSLOTNB	0x3D	[12:8] ⁽¹⁾	0b00000 0b00001 ⁽²⁾ 0b00011 0b00111 0b01111 0b11111	Unprogrammed part Programmed once, 4 slots remaining Programmed twice, 3 slots remaining Programmed 3 times, 2 slots remaining Programmed 4 times, 1 slot remaining Programmed 5 times, no slot remaining
SF4	0x48	[18:0] ⁽¹⁾	See Table 9	Scale Factor 4th order coefficient (calibrated angular rate)
SF3	0x46	[19:0] ⁽¹⁾	See Table 9	Scale Factor 3rd order coefficient (calibrated angular rate)
SF2	0x44	[20:0] ⁽¹⁾	See Table 9	Scale Factor 2nd order coefficient (calibrated angular rate)
SF1	0x42	[29:0] ⁽¹⁾	See Table 9	Scale Factor 1st order coefficient (calibrated angular rate)
SF0	0x3F	[30:0] ⁽¹⁾	See Table 9	Scale Factor constant coefficient (calibrated angular rate)
B4	0x47	[18:0] ⁽¹⁾	See Table 9	Bias 4th order coefficient (calibrated angular rate)
B3	0x45	[19:0] ⁽¹⁾	See Table 9	Bias 3rd order coefficient (calibrated angular rate)
B2	0x43	[19:0] ⁽¹⁾	See Table 9	Bias 2nd order coefficient (calibrated angular rate)
B1	0x41	[29:0] ⁽¹⁾	See Table 9	Bias 1st order coefficient (calibrated angular rate)
B0	0x3E	[23:0] ⁽¹⁾	See Table 9	Bias constant coefficient (calibrated angular rate)
TMID	0x40	[19:0] ⁽¹⁾	See Table 9	Mid-temperature calibration point

Table 8: Useful parameters information

Notes:

- (1) The other bits at those addresses shall remain unchanged. Please make sure that you write them without modification!
- (2) Default Value

6.6. Modification of the data rate

GYPRO®4300 can be used in a wide variety of inertial systems (IMU, INS, AHRS, stabilization platform...) having different data processing capabilities depending on the target application. In order to make sure the output data from the sensors is properly processed at system-level (eg: avoid data overflow on the microcontroller data bus), Tronics provides the capability to increase or decrease the output data rate of GYPRO®4300 product.

The formula below gives the data rate:

$$\text{Data rate [Hz]} = \frac{30000}{\text{ODRSEL} + 1}$$

The default decimal value for ODRSEL is 15 [0b001111] but it can be tuned from 0 (corresponding to a data rate of 30 kHz) to 49 (data rate of 600 Hz). To tune this parameter, please refer to subsection 6.5.1.

In order to avoid data aliasing and to ensure a reliable vibration rectification error (VRE), we recommend keeping the data rate above 900 Hz, corresponding to ODRSEL = 31.

IMPORTANT NOTE: As the default ODRSEL value is already programmed in the OTP and cannot be rewritten, the custom value needs to be loaded in the System Register each time the sensor is powered on.



7. Angular rate calibration procedure

7.1. Algorithm overview

After the filtering stage, the raw angular rate sensor output is temperature compensated based on the on-chip temperature sensor output and the stored temperature compensation parameters.

7.1.1. Angular rate output calibration model

The formula below models the link between raw and compensated angular rate outputs:

$$\text{RATE}[^{\circ}/\text{s}] = \frac{\text{RATE}_{\text{COMP}}[\text{LSB}]}{\text{SF}_{\text{setting}}[\text{LSB}/^{\circ}/\text{s}]} = \frac{\text{RATE}_{\text{RAW}}[\text{LSB}] - \text{BIAS}[\text{LSB}]}{\text{SF}[\text{LSB}/^{\circ}/\text{s}]}$$

where:

- RATE is the angular rate output converted in °/s;
- RATE_{COMP} is the calibrated angular rate output;
- SF_{setting} is the constant conversion factor from LSB to °/s for the calibrated angular rate output. Default value for this parameter is SF_{setting} = 10 000;
- RATE_{RAW} is the raw data angular rate output;
- BIAS is a polynomial (4th degree) temperature-varying coefficient to model the sensor's bias temperature variations;
- SF is a polynomial (4th degree) temperature-varying coefficient to model the sensor's Scale Factor temperature variations.

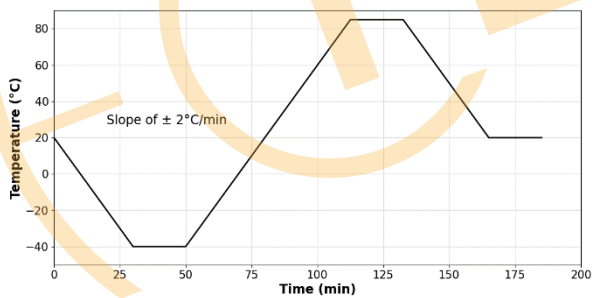

Figure 25: Recommended Temperature profile for calibration

¹ Temperature profile can be adapted to be in line with customer applications.

² Rate applied can be adapted to be in line with customer applications.

7.1.2. Recommended procedure

1. Set GOUT_SEL to 0 in the System Registers (disable the calibration)
2. Place the sensor on a rate table in a thermal chamber and implement temperature profile according to Figure 25
3. Perform continuous acquisition of the angular rate output with the following pattern:
 - Rest position (0°/s input) to evaluate the BIAS parameter
 - + 300°/s input then -300°/s input to evaluate the SF parameter²
4. Calculate the coefficients of BIAS and SF polynomials:

$$\text{BIAS} = \sum_{i=0}^4 b_i (T_{\text{RAW}} - T_{\text{MID}})^i$$

$$\text{SF} = \sum_{i=0}^4 sf_i (T_{\text{RAW}} - T_{\text{MID}})^i$$

where

- T_{RAW} is the raw output of the temperature sensor multiplied by 64;
 - T_{MID} is the mid-value of T_{RAW};
 - b₀ to b₄ are the 5 coefficients of BIAS polynomial;
 - sf₀ to sf₄ are the 5 coefficients of SF polynomial.
5. Convert T_{MID}, b_i and sf_i parameters to their binary values according to Table 9 below:

Parameter	Value (decimal)	Format
SF4	sf ₄ · 2 ⁹² / SF _{setting}	signed 2's comp
SF3	sf ₃ · 2 ⁷² / SF _{setting}	signed 2's comp
SF2	sf ₂ · 2 ⁵⁵ / SF _{setting}	signed 2's comp
SF1	sf ₁ · 2 ⁴⁶ / SF _{setting}	signed 2's comp
SF0	sf ₀ · 2 ²⁷ / SF _{setting}	signed 2's comp
B4	b ₄ · 2 ⁷³	signed 2's comp
B3	b ₃ · 2 ⁵³	signed 2's comp
B2	b ₂ · 2 ³²	signed 2's comp
B1	b ₁ · 2 ²⁰	signed 2's comp
B0	b ₀	signed 2's comp
TMID	T _{MID}	unsigned

Table 9: Angular rate calibration parameters

GYPRO4300 Datasheet

7.2. Programming of the new coefficients

IMPORTANT NOTE: The following steps are non-reversible. The previous values of the coefficients will not be accessible anymore. The temperature compensation coefficients can be re-programmed up to 4 additional times on the IC.

The programming procedure consists in three major steps:

- Checking the available MTP slot status
- Programming the coefficients
- Updating the available MTP slot status

An overview of the procedure is given in 25.

7.2.1. Checking the MTP slot status

The first step is to check the number of remaining MTP slots (MTPSLOTNB), in other words, checking how many times the chip has been programmed before.

The detailed information of MTPSLOTNB register content is given in Table 8. The sequence of instructions to read the register is given in section 6.5.

The MTP slot number (MTPSLOTNB) re-programming iteration is given in the following Table 10:

Iteration	Correspondence	MTP number	
		Value	Binary
0	Unprogrammed part	0	00000
1	Programmed once	1*	00001
2	Programmed twice	3	00011
3	...	7	00111
4		15	01111
5	Cannot be further programmed	31	11111

Table 10: MTPSLOTNB iterations

* Default value

7.2.2. Programming the coefficients

This step describes the procedure for programming the calculated coefficients (temperature compensation of angular rate output). The programming procedure is:

1. Write SF4 in the system register
2. Program SF4 in the MTP
3. Write SF3 in the system register
4. Program SF3 in the MTP
5. Write SF2 in the system register
6. Program SF2 in the MTP
7. Write SF1 in the system register
8. Program SF1 in the MTP
9. Write SF0 in the system register
10. Program SF0 in the MTP
11. Write B4 in the system register

12. Program B4 in the MTP
13. Write B3 in the system register
14. Program B3 in the MTP
15. Write B2 in the system register
16. Program B2 in the MTP
17. Write B1 in the system register
18. Program B1 in the MTP
19. Write B0 in the system register
20. Program B0 in the MTP
21. Write TMID in the system register
22. Program TMID

The detailed SPI commands are given in section 6.5. The detailed information about each coefficient is given in Table 8.

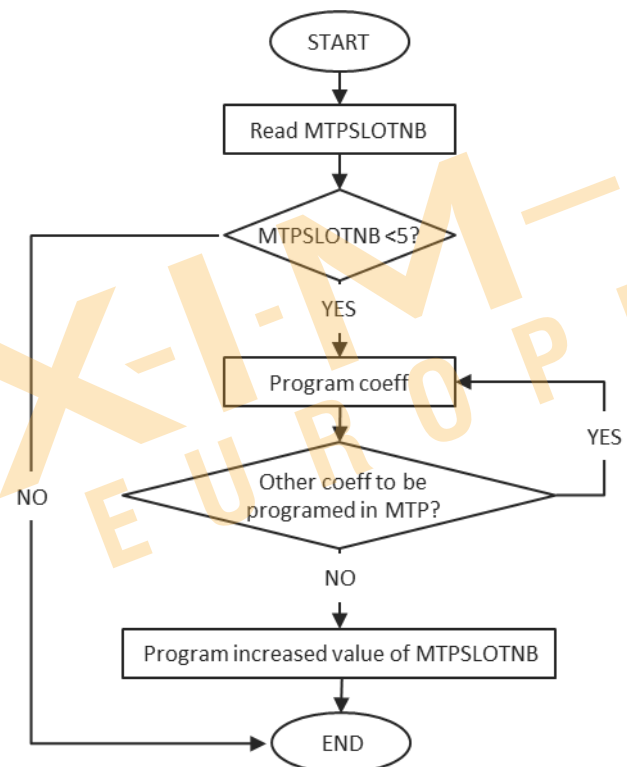

Figure 26: Procedure to program new calibration parameters

7.2.3. Updating MTP slot status

This section describes the procedure for programming the updated status of the MTP slots.

If this step is not performed properly, the new compensation coefficients will not be effective.

1. Read the MTPSLOTNB as described in section 6.5.2
2. Increment MTPSLOTNB according Table 9.
3. Write the updated MTPSLOTNB in the system register.
4. Program the updated MTPSLOTNB in the MTP.
5. After a reset, the new coefficients will be available.

7.3. Switch to uncompensated data output

To optimize the thermal compensation of the angular rate output, it is possible to disable the on-chip compensation and use the uncompensated (raw) output to perform an external thermal compensation.

IMPORTANT NOTE: This step is non-reversible. The previous values of the coefficients will not be accessible anymore.

To switch the angular rate output to uncompensated data, the procedure is exactly the same as described in section 7.2, but the coefficients given in Table 9 must be replaced by the coefficients given below in Table 11.

Parameter	Value (hexadecimal)
SF4	0x0
SF3	0x0
SF2	0x0
SF1	0x0
SF0	0x0800 0000
B4	0x0
B3	0x0
B2	0x0
B1	0x0
B0	0x0
TMID	0x0

Table 11: Angular rate compensation coefficients to obtain raw data

8. Temperature Sensor Calibration Procedure

The temperature output of GYPRO4300 sensors is not factory-calibrated, since only the relative temperature output is needed to perform temperature compensation of the angular rate output. However, it is possible to perform a first-order polynomial calibration of the temperature sensor, in order to output the absolute temperature information.

This section shows how to get and store temperature calibration parameters for the temperature output.

8.1. Temperature sensor calibration model

The formula below models the link between raw and calibrated temperature output:

$$T[^{\circ}\text{C}] = \frac{T_{\text{COMP_OUT}}[\text{LSB}]}{\text{GAIN}_{\text{setting}}[\text{LSB}/^{\circ}\text{C}]} = \frac{\text{GAIN} \cdot T_{\text{RAW}}[\text{LSB}] - \text{OFFSET}[\text{LSB}]}{\text{GAIN}_{\text{setting}}[\text{LSB}/^{\circ}\text{C}]}$$

where:

- T is the output temperature converted in °C;
- T_{COMP_OUT} is the calibrated temperature output;
- GAIN_{setting} is the constant conversion factor from LSB to °C for the calibrated temperature output. This gain is set to 85LSB/°C;
- T_{RAW} is the raw data temperature output;
- OFFSET is a constant coefficient to tune the offset;
- GAIN is a constant coefficient to tune gain.

The OFFSET and GAIN parameters will be computed and written in the ASIC as per the following calibration procedure.

8.2. Recommended Procedure

1. Check that TOUT_SEL = 0. If not, set it to 0 in the System Registers.
2. Measure the temperature output with at least 2 temperature points T₁ and T₂.

3. Calculate the GAIN and OFFSET coefficients according to formula above

$$\text{GAIN} = \text{GAIN}_{\text{setting}} \cdot \frac{T1_{\text{ABS}}[^{\circ}\text{C}] - T2_{\text{ABS}}[^{\circ}\text{C}]}{T1_{\text{RAW}}[\text{LSB}] - T2_{\text{RAW}}[\text{LSB}]}$$

$$\text{OFFSET} = \text{GAIN}_{\text{setting}} \cdot T1_{\text{ABS}}[^{\circ}\text{C}] - \text{GAIN} \cdot T1_{\text{RAW}}[\text{LSB}]$$

where:

- T_{1ABS} is the absolute temperature of T₁ in °C;
- T_{2ABS} is the absolute temperature of T₂ in °C;
- T_{1RAW} is the raw output temperature of T₁ in LSB;
- T_{2RAW} is the raw output temperature of T₂ in LSB;

4. Convert GAIN and OFFSET to their binary values according to Table 12 below:

Parameter	Value (decimal)	Format
G	GAIN · 2 ¹¹	Unsigned
O	OFFSET	Unsigned

Table 12: Temperature calibration parameters

5. [Optional step: Write GAIN and OFFSET into the System Registers and repeat step 2. to check the accuracy of the new calibration.]
6. Write GAIN and OFFSET into the MTP according to instructions of Section 6.5.2. Meanwhile, set TOUT_SEL to 1 during this step, so that the new calibration parameters are effective after a RESET.

9. Device Identification / Ordering information

9.1. Device identification

GYPRO4300 tracking information is accessible on the label, as shown in the Figure 27.

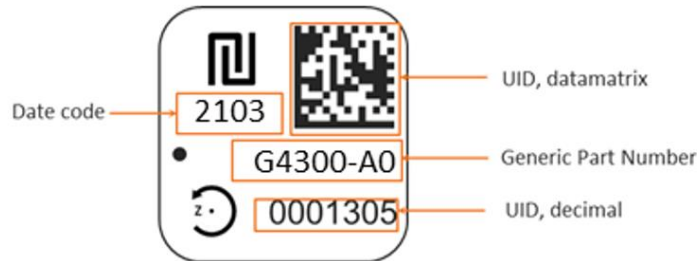

Figure 27: GYPRO4300 label.

9.2. Ordering information

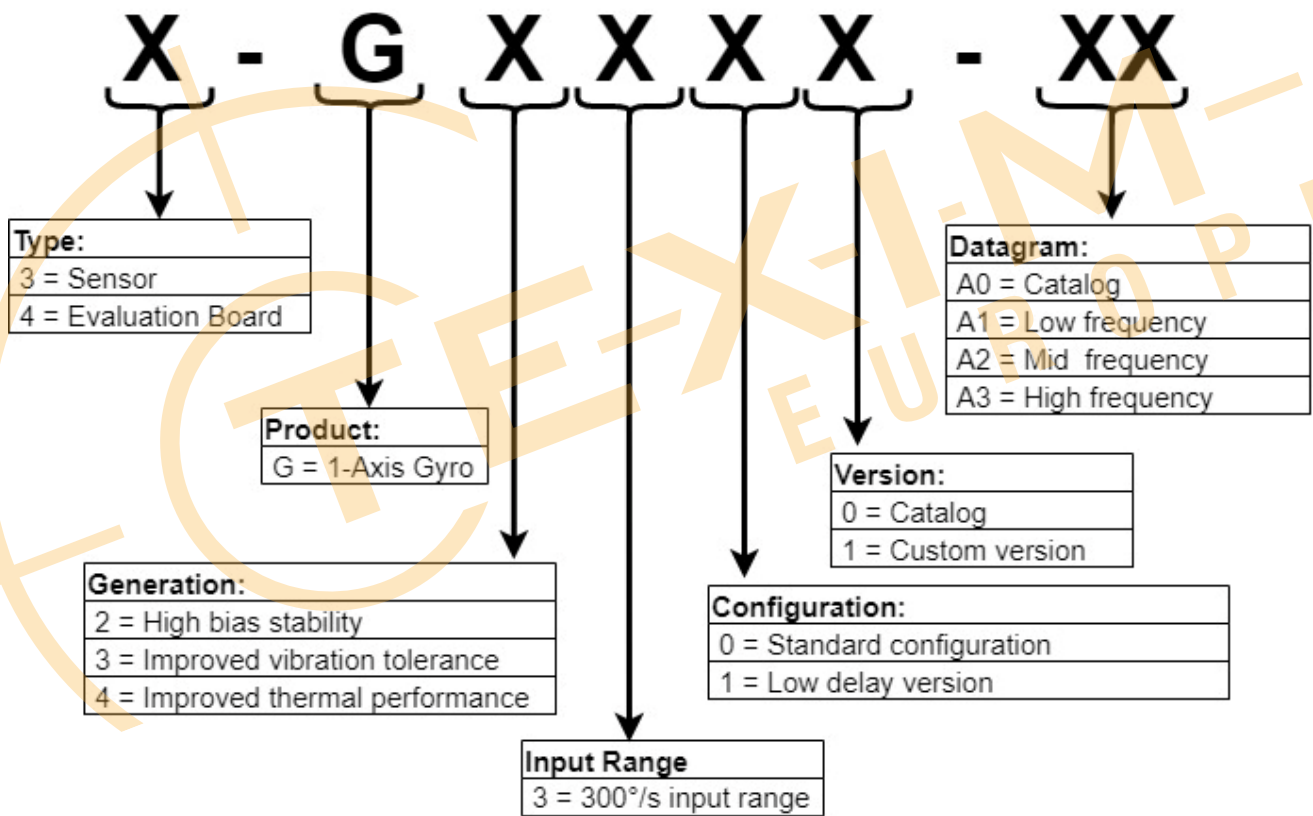

Figure 28: Ordering information

Product	Ordering code
GYPRO4300 – Catalog	3-G4300-A0
GYPRO4300 – Low frequency	3-G4300-A1
GYPRO4300 – Mid frequency	3-G4300-A2
GYPRO4300 – High frequency	3-G4300-A3
GYPRO4300-EVB3	4-G4300-A0

Table 13: Product ordering code

10. Internal construction and Theory of Operation

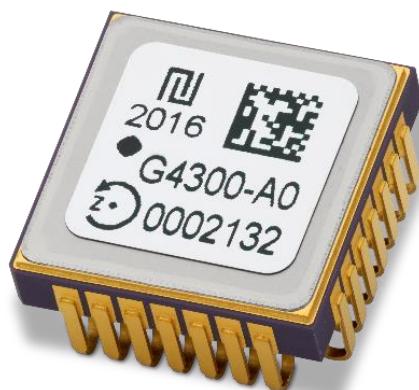

Figure 29: GYPRO4300 package

GYPRO series is using the dominant architecture for high performance MEMS gyro, namely the “Tuning fork or dual mass” design.

In details, each sensor consists in a MEMS transducer and an integrated circuit (IC) packaged in a 28-pins J-lead Ceramic Package.

The sensing element (MEMS die) is manufactured using Tronics' wafer-level packaging technology based on micro-machined thick single crystal silicon. The MEMS consists of two coupled sub-structures subjected to linear anti-phase vibrations. The structures are vacuumed at the wafer-level providing high Q-factor in the drive mode. The drive system is decoupled from the sense system in order to reduce feedback from sense motion to drive electrodes. The drive anti phase vibration is sustained by electrostatic comb drives. The sense anti phase vibration resulting from Coriolis forces is counter balanced by electrostatic forces. Differential detection and actuation are used for both drive and sense systems and for each sub-structure, keeping two identical structures for efficient common mode rejection.

The integrated circuit (IC) is designed to interface the MEMS sensing element. It includes ultra-low noise capacitive to voltage converters (C2V) followed by high resolution voltage digitization (ADC) for both drive and sense paths. Excitation voltage required for capacitance sensing circuits is generated on the common electrode node. 1-bit force feedbacks (DAC) are used for both drive and sense system actuation.

The choice for the implemented closed-loop architecture based on a Sigma-Delta principle is particularly well adapted as it brings the following key advantages:

1) Sigma-Delta is well suited for low-frequency signals. Noise shaping principle rejects quantization noise in high frequency bands.

2) Simplicity of hardware implementation. Oversampling concept allows significant design relaxation of the analog detection chain signal resolution. Additionally the voltage reference used for actuation force feedback is also of simple implementation as it is a 1-bit D/A converter, thus simplifying its design.

3) Linearization of the electrostatic forces thanks to the Sigma-delta principle (through force averaging) furthermore reduces non-linearity overall and more importantly its even-order terms, which result in rectification error.

4) Sigma-Delta signal output is inherently a digital signal, thus suppressing the need for costly high resolution A/D converter.

The digital part implements digital drive and sense loops, demodulates, decimates and processes the gyro output based on the on-chip temperature sensor output. The system controller manages the interface between the SPI registers, the system register and the non-volatile memory (OTP). The non-volatile memory provides the gyro settings, in particular the coefficients for angular rate sensor temperature compensation. On power up, the gyro settings are transferred from the OTP to the system registers and output data are available in the SPI registers. The angular rate sensor output and the temperature sensor output are available in the SPI registers. The SPI registers are available through the SPI interface (SSB, SCLK, MOSI, and MISO). The self-test and the data ready are available respectively on the external pins ST and DRDY.

The “References” block generates the required biasing currents and voltages for all blocks as well as the low-noise reference voltage for critical blocks.

The “Power Management” block manages the power supply of the sensor from a single 5V supply between the VDD and GND pins. It includes a power on reset as well as an external reset pin (RSTB) to start or restart operation using default configuration. An enable pin (EN) with power-down capability is also available.

The sensor is powered with a single 5V DC power supply through pins VDD and GND. Although the sensor contains three separate VDD pins, the sensor is supplied by a single 5V voltage source. It is recommended to supply the three VDD pins in a star connection with appropriate decoupling capacitors. Regarding the sensor grounds, all the GND pins are internally shorted. The GND pins redundancy is used for multiple bonds in order to reduce the total ground inductance. It is therefore recommended to connect all the GND pins to the ground.

11. Available Tools and Resources

The following tools and resources are available on our [website](#) or upon request.







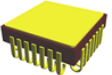

Item	Description
Documentation & technical notes	
	GYPRO4300 - Flyer
Mechanical tools	
	GYPRO4300 – 3D model
Evaluation kit	
	GYPRO4300-EVB3 – Evaluation board Evaluation board for GYPRO4300, compatible with Arduino Leonardo
	GYPRO® Evaluation Board – User manual
	GYPRO® Evaluation Kit – Quick start guide
	GYPRO® Evaluation Tool – Software user manual
	GYPRO® Evaluation Tool – Tutorial Installation and programming of the Evaluation kit
	GYPRO® Evaluation Tool – Tutorial Software
	GYPRO® Evaluation Tool – Software
	GYPRO® Evaluation Tool – Arduino Firmware

Table 14: Available tools and resources

12. Revision History

Item	Datasheet Version
MCD015-I	
RSTB pin level	Update RSTB Pin level to VDDIO in Table 3
Soldering reflow profil	Supress Sn-Pb wording in Table 4
MCD015-H	
ODRSEL register address	Correction of ODRSEL parameter register address
MCD015-G	
Product life cycle update	Product maturity from Serial Samples to Production
Data rate modification	Add data rate modification section
Distribution update	Bias over temperature, scale factor over temperature, scale factor non linearity, RMS Noise and Bias instability
Residual Bias Temperature Error	Nominal value changed
Bias Instability (Allan Variance)	Nominal value changed
Angular random walk	Nominal value changed
Residual scale factor Temperature Error	Nominal value changed
Scale Factor nonlinearity	Nominal value changed
MCD015-F	
Center of mass	Add center of mass to overall dimensions section
SPI timing diagram	Correction of SPI timing diagram (SPI mode 0)
Pin naming	GREF pin renamed to LVREF
MCD015-E	
Pinout ordering	Pinout ordering changed from clockwise to a counterclockwise format when looking at the sensor from the top
Bias Instability (Allan Variance)	Nominal value changed, maximum value added
Bias in-run stability (short-term)	Nominal value changed
Residual Bias Temperature Error (1 σ)	Nominal value changed
Residual Scale Factor Temperature Error (1 σ)	Nominal value changed
Scale factor run-to-run repeatability	Nominal value changed
RMS Noise [0 ; 100 Hz]	Nominal value changed
G-sensitivity	Nominal value changed

Disclaimer

ALL PRODUCTS, PRODUCT SPECIFICATIONS AND DATA ARE SUBJECT TO CHANGE WITHOUT NOTICE TO IMPROVE RELIABILITY, FUNCTION OR DESIGN OR OTHERWISE.

Texim Europe B.V. its affiliates, agents, and employees, and all persons acting on its or their behalf (collectively, "Texim"), disclaim any and all liability for any errors, inaccuracies or incompleteness contained in any datasheet or in any other disclosure relating to any product.

Texim makes no warranty, representation or guarantee regarding the suitability of the products for any particular purpose or the continuing production of any product.

It is the customer's responsibility to validate that a particular product with the properties described in the product specification is suitable for use in a particular application.

Parameters provided in datasheets and / or specifications may vary in different applications and performance may vary over time.

All operating parameters, including typical parameters, must be validated for each customer application by the customer's technical experts.

Please contact us if you have any questions about the contents of the datasheet.

This may not be the latest version of the datasheet. Please check with us if a later version is available.

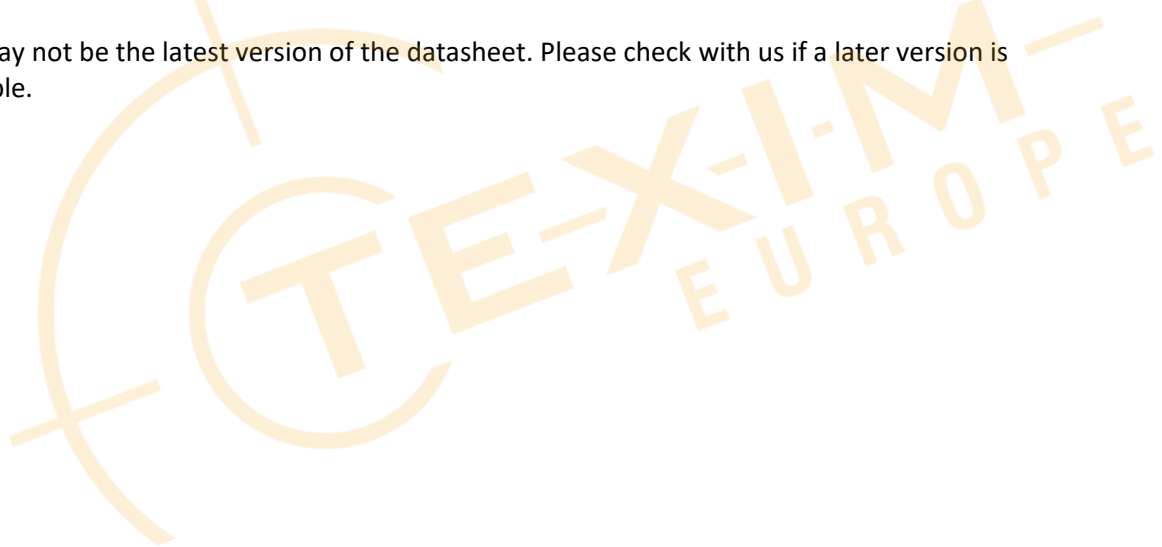



Headquarters & Warehouse

Elektrostraat 17
NL-7483 PG Haaksbergen
The Netherlands

T: +31 (0)53 573 33 33
E: info@texim-europe.com
Homepage: www.texim-europe.com



The Netherlands

Elektrostraat 17
NL-7483 PG Haaksbergen

T: +31 (0)53 573 33 33
E: nl@texim-europe.com



Belgium

Zuiderlaan 14, box 10
B-1731 Zellik

T: +32 (0)2 462 01 00
E: belgium@texim-europe.com



UK & Ireland

St Mary's House, Church Lane
Carlton Le Moorland
Lincoln LN5 9HS

T: +44 (0)1522 789 555
E: uk@texim-europe.com



Germany - North

Bahnhofstrasse 92
D-25451 Quickborn

T: +49 (0)4106 627 07-0
E: germany@texim-europe.com

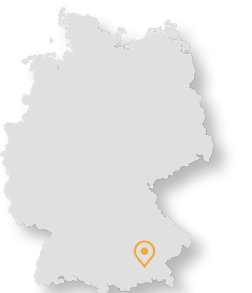

Germany - South

Martin-Kollar-Strasse 9
D-81829 München

T: +49 (0)89 436 086-0
E: muenchen@texim-europe.com



Austria

Warwitzstrasse 9
A-5020 Salzburg

T: +43 (0)662 216 026
E: austria@texim-europe.com



Nordic

Søndre Jagtvej 12
DK-2970 Hørsholm

T: +45 88 20 26 30
E: nordic@texim-europe.com



Italy

Martin-Kollar-Strasse 9
D-81829 München

T: +49 (0)89 436 086-0
E: italy@texim-europe.com