

# DATENBLATT – Data sheet

## MECHANISCHE DATEN *Mechanical data*

- **GEHÄUSE:** **M12 Stecker gerade, schwarz–  
M12 Stecker gerade, schwarz**  
*Housing: M12 male straight, black–  
M12 male straight, black*
- **VERSCHRAUB.:** **2x M12x1 Schraube  
Zinkdruckguss vernickelt**  
*Screw: 2x M12x1 screw  
Zinc pressure die casting surface Ni*
- **BEFESTIGUNG:** **aufgesteckt, verschraubt, SW 13  
empfohlenes Anzugsmoment 0.6Nm**  
*Connection: pluggable, screw locking, A/F 13  
recommended breakaway torque 0,6Nm*
- **TEMP.-BEREICH:** **-25°C ... +85°C (nur für Steckverbinder,  
Kabel siehe Seite 2)**  
*Temp. range: -25...+85°C (only for connector,  
cable see page 2)*
- **SCHUTZGRAD:** **IP65/67**  
*Protection: IP65/67*

## ELEKTRISCHE DATEN *Electrical data*

- **ANSCHLUSSSPG.:** **max. 60 V AC/DC**  
*Nominal voltage: max. 60 V AC/DC*
- **BETRIEBSSTROM:** **max. 4 A je Kontakt**  
*Rated current : max. 4 A every contact*
- **BEM.-STOSSPANNUNG:** **1,5 kV**  
*Rated impulse voltage: 1,5 kV*
- **VERSCHMUTZUNGSGRAD:** **3**  
*Pollution degree: 3*
- **ISOLIERSTOFFGRUPPE:** **Kategorie I**  
*Material group: Kategorie I  
nach IEC 60664-1  
Category I according to  
IEC 60664-1*
- **FELDBUS:** **CANopen / DeviceNet**  
*fieldbus*
- **NORM:** **DIN EN 61076-2-101**  
*standard: DIN EN 61076-2-101*

## TECHNISCHE SKIZZE / Technical sketch

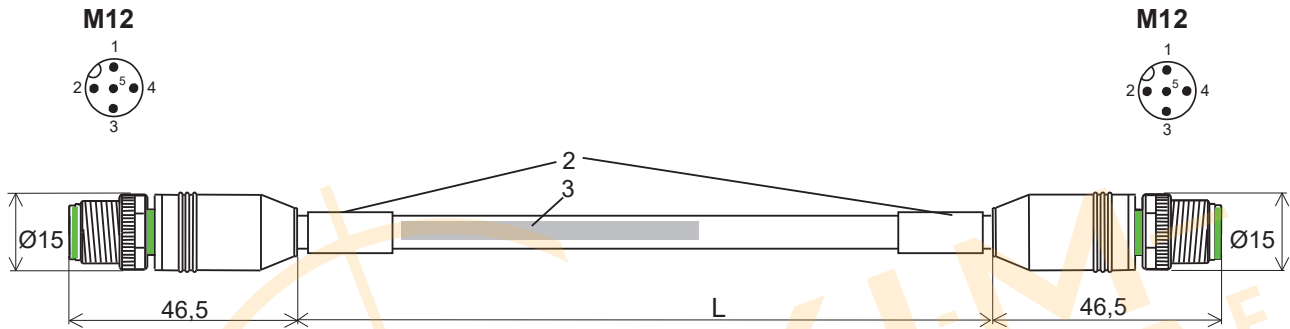

- 1) Ohne Kontur für Wellenschlauch  
*No corrugated tube contour*
- 2) Kabeltülle  
*Cable sleeve*

- 3) Kabelaufdruck lt. Bedruckungsvorschrift 7000-08001  
*Cable imprint see printing instruction 7000-08001*

## STROMLAUFPLAN / Schematic diagram

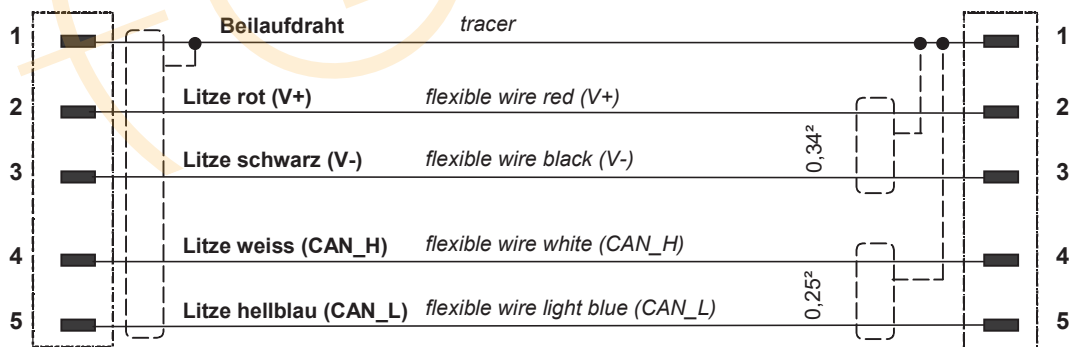

|      |                   |             |                      | Datum/Date | Name                  | <b>Datenblatt / Data sheet</b><br><b>Stromlaufplan / Schematic diagram</b>   |  |  |  |
|------|-------------------|-------------|----------------------|------------|-----------------------|--|--|--|--|
|      |                   |             | Freigeg.<br>Released | 30.6.20    | PM                    |  |  | <b>Art. No.: 7000-40532-xxxxyyyy</b><br>xxx – Kabelnummer / <i>cable No.</i><br>yyyy – Kabellänge L [cm] / <i>cable length</i> |  |
|      |                   |             | Gepr.<br>Approved    | 30.6.20    | Schu                  | M12 Stecker A-kodiert gerade auf<br>M12 Stecker A-kodiert gerade<br>M12 male A-coded straight with<br>M12 male A-coded straight<br>Belegung / <i>configuration</i> 1,2,3,4,5 |  |  |  |
| Idx. | Änderung / Update | Datum/ Date | Name                 |            |                       |  |  |  |  |
| a    | Erstausgabe       | 30.6.20     | Schr                 | 08.11.2021 | 7000-40532_db_2_a.doc |  |  |  |  |

**KABEL (geschirmt) / Cable (shielded)**

| Kabel- No.<br>xxx<br>cable no.<br>xxx | Mantel-<br>werkstoff<br>jacket<br>material | Mantel-<br>farbe<br>jacket<br>color | Ader-<br>isolation<br>wire<br>isolation | Aderfarben<br>wire colors                                      | Litzen<br>[mm <sup>2</sup> ]<br>flex. wire                         | Kabel-<br>mantel-Ø<br>cable<br>jacket Ø | Zulassungen<br>Kabel<br>Standards cable | Kabel-<br>typ<br>cable<br>type |
|---------------------------------------|--|-------------------------------------|---|--|--|---|---|--------------------------------|
| 803                                   | PUR  | violett<br>violet                   | PE                                      | (weiss, blau) + (rot, schwarz)<br>(white, blue) + (red, black) | 2 x AWG<br>24/19<br>(2 x 0,241)<br>2 x AWG<br>22/19<br>(2 x 0,382) | 6,9 ± 5%                                | UL (cURus)                              |                                |

**Toleranz Kabellängen:** 0m < L ≤ 0,5m +0,03m      1,0m < L ≤ 3,0m +0,1m  
 Tolerance cable length : 0,5m < L ≤ 1,0m +0,05m      3,0m < L ±1,5%

**Temperaturbereich Kabel:** / temperature range for cables:

| Kabel / cable | bewegter Einsatz / (for flexible use) | fest verlegt / (for stationary use) |
|---------------|---------------------------------------|-------------------------------------|
| 803           | -30°C ... +70°C                       | -40°C ... +80°C                     |

**ZULASSUNGEN STECKVERBINDER / Certifications connectors**

**Kennzeichnung auf Produkt / Verpackung / labeling on product / packaging**

keine / no

**VERPACKUNG / Packing instruction**

Siehe Verpackungsvorschrift VP 7000-12001.  
 See packing instruction VP 7000-12001.

**BESTÄNDIGKEIT / Resistance**

Gute Chemikalien- und Ölbeständigkeit (Ölbeständigkeit gilt nicht für den Einsatz mit PVC-Kabel).  
 Beim Einsatz aggressiver Medien ist die Materialbeständigkeit applikationsbezogen zu überprüfen.  
 Good chemical and oil resistance (articles with PVC-cable are not oil resistant).  
 When using aggressive mediums, material resistance based on application must be checked.

| Idx. | Änderung / Update | Datum/ Date | Name | Datum/Date           | Name                  | <b>Datenblatt / Data sheet</b><br><b>Stromlaufplan / Schematic diagram</b>  |
|------|-------------------|-------------|------|----------------------|-----------------------|---|
|      |                   |             |      | Freigeg.<br>Released | 30.6.20               |   |
|      |                   |             |      | Gepr.<br>Approved    | 30.6.20               | Schu  |
|      |                   |             |      |                      |                       | <b>Art. No.: 7000-40532-xxxyyyy</b><br>xxx – Kabelnummer / cable No.<br>yyyy – Kabellänge L [cm] / cable length   |
|      |                   |             |      |                      |                       | M12 Stecker A-kodiert gerade auf<br>M12 Stecker A-kodiert gerade<br>M12 male A-coded straight with<br>M12 male A-coded straight<br>Belegung / configuration 1,2,3,4,5 |
| a    | Erstausgabe       | 30.6.20     | Schr | 08.11.2021           | 7000-40532_db_2_a.doc | Blatt<br>2 von 2<br>Sheet   |

## **Disclaimer**

ALL PRODUCTS, PRODUCT SPECIFICATIONS AND DATA ARE SUBJECT TO CHANGE WITHOUT NOTICE TO IMPROVE RELIABILITY, FUNCTION OR DESIGN OR OTHERWISE.

Texim Europe B.V. its affiliates, agents, and employees, and all persons acting on its or their behalf (collectively, "Texim"), disclaim any and all liability for any errors, inaccuracies or incompleteness contained in any datasheet or in any other disclosure relating to any product.

Texim makes no warranty, representation or guarantee regarding the suitability of the products for any particular purpose or the continuing production of any product.

It is the customer's responsibility to validate that a particular product with the properties described in the product specification is suitable for use in a particular application.

Parameters provided in datasheets and / or specifications may vary in different applications and performance may vary over time.

All operating parameters, including typical parameters, must be validated for each customer application by the customer's technical experts.

Please contact us if you have any questions about the contents of the datasheet.

This may not be the latest version of the datasheet. Please check with us if a later version is available.





## Headquarters & Warehouse

Elektrostraat 17  
NL-7483 PG Haaksbergen  
The Netherlands

T: +31 (0)53 573 33 33  
E: info@texim-europe.com  
Homepage: www.texim-europe.com



### The Netherlands

Elektrostraat 17  
NL-7483 PG Haaksbergen

T: +31 (0)53 573 33 33  
E: nl@texim-europe.com



### Belgium

Zuiderlaan 14, box 10  
B-1731 Zellik

T: +32 (0)2 462 01 00  
E: belgium@texim-europe.com



### UK & Ireland

St Mary's House, Church Lane  
Carlton Le Moorland  
Lincoln LN5 9HS

T: +44 (0)1522 789 555  
E: uk@texim-europe.com



### Germany - North

Bahnhofstrasse 92  
D-25451 Quickborn

T: +49 (0)4106 627 07-0  
E: germany@texim-europe.com



### Germany - South

Martin-Kollar-Strasse 9  
D-81829 München

T: +49 (0)89 436 086-0  
E: muenchen@texim-europe.com



### Austria

Warwitzstrasse 9  
A-5020 Salzburg

T: +43 (0)662 216 026  
E: austria@texim-europe.com



### Nordic

Søndre Jagtvej 12  
DK-2970 Hørsholm

T: +45 88 20 26 30  
E: nordic@texim-europe.com



### Italy

Martin-Kollar-Strasse 9  
D-81829 München

T: +49 (0)89 436 086-0  
E: italy@texim-europe.com