

Shenzhen Leadtek Electronics Co.,Ltd

PRODUCT SPECIFICATION

TFT-LCD MODULE

Module No: LTK040MNBCT24-V0

- Preliminary Specification
- Approval Specification

Designed by	Checked by	Approved by
<i>jona</i>	<i>tom</i>	<i>lan</i>

Final Approval by Customer

Approved by	Comment
	Distributed by:  www.texim-europe.com

※The specification of "TBD" should refer to the measured value of sample . If there is difference between the design specification and measured value, we naturally shall negotiate and agree to solution with customer.

1.General Specifications

No.	Item	Specification	Unit	Remar
1	LCD Size	TFT"3.99	inch	-
2	Panel Type	IPS	-	-
3	Display Resolution	400xRGBx960	Pixel	-
4	Display Mode	Normally Black	-	-
5	Number of Colors	16.7M	-	-
6	Viewing Direction	ALL	-	Note1
7	NTSC	65%	-	Typ.
8	Contrast Ratio	1500	-	-
9	CTP+LCM Luminance	410	cd/m2	Typ
10	CTP+LCM Module size	45.90(H)x105.08(V)x4.20(T)	mm	Note1
11	Active Area	39.18(H)x94.03(V)	mm	Note1
12	Pixel Pitch	0.1497(H)x0.1462(V)	mm	-
13	Pixel Arrangement	RGB Vertical Stripe	-	-
14	Weight	TBD	g	-
15	TFT Driver IC	ST7701SN	-	-
16	Light Source	white LED8	-	-
17	Interface	MIPI 2-lane	-	-
18	Operating Temperature	-20~+70	°C	-
19	Storage Temperature	-30~+80	°C	-

Note 1: Please refer to the mechanical drawing ;

2.Pin Assignments

Pin No.	Symbol	Function
1	CTP_GND	CTP_Power Ground
2	CTP_VDD	CTP power supply Pin
3	CTP_SCL	CTP I2C clock Power Supply for I/O System
4	CTP_SDA	CTP I2C data Power supply
5	CTP_INT	CTP interrupt Tearing effect signal output
6	CTP_RES	CTP reset Pin
7	GND	Power Ground
8	GND	Power Ground
9	D0N	MIPI DSI differential data 0 negative
10	D0P	MIPI DSI differential data 0 positive
11	GND	Power Ground
12	CLKN	MIPI DSI differential clock negative
13	CLKP	MIPI DSI differential clock positive
14	GND	Power Ground
15	D1N	MIPI DSI differential data 1 negative
16	D1P	MIPI DSI differential data 1 positive
17	GND	Power Ground
18	RESET	Reset signal (Low: Active)
19	TE	Not connect
20	IOVCC	TFT power supply 1.8-2.8V
21	VCI_3.3V	TFT power supply 2.8V
22	NC	Not connect
23	LEDA	LED anode
24	NC	Not connect
25	LEDK	LED cathode.

3. Electrical Specification

3.1 Absolute Maximum Ratings

Item	Symbol	Value	Unit	Remark
Power Supply Voltage	VCI	2.65-3.6	V	-
Power Supply Voltage	IOVCC	1.65-3.3	V	

3.2 Typical Operation Conditions

Item	Symbol	Min.	Typ.	Max.	Unit
Analog Supply Voltage	VCI	2.65	3.3	3.6	V
I/O Supply Voltage	IOVCC	1.65	1.8	3.3	
Input High Voltage	V _{IH}	0.7* IOVCC	-	IOVCC	V
Input Low Voltage	V _{IL}	0	-	0.3* IOVCC	V
Output High Voltage	V _{OH}	0.8* IOVCC	-	-	V
Output Low Voltage	V _{OL}	-	-	0.2* IOVCC	V

3.3 Backlight Circuit Characteristics

PARAMETER	Sym.	Min.	Typ.	Max.	Unit	Test Condition	Note
LED Current	IF	-	20	-	mA	-	-
LED Voltage	VF	-	24.8	-	V	-	-
CTP+LCM Brightness	Lv	-	410	-	Nits	@CA310	
Life Time		-	30000	-	Hr.	I ≤ 20mA	-
Color	White						

4.Timing

MIPI interface High speed mode

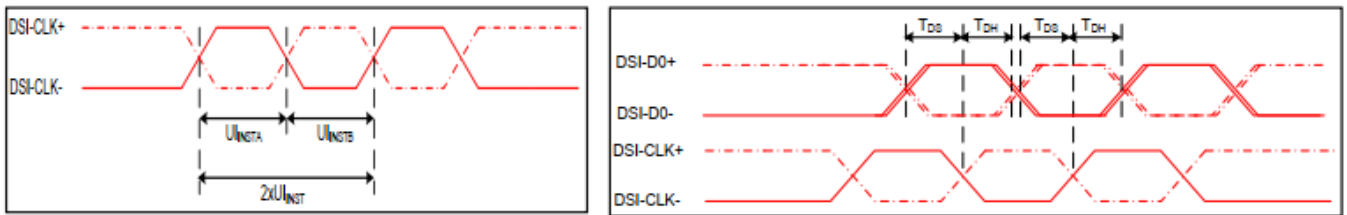

DSI clock channel timing

$VDDI=1.8, VDD=2.8, AGND=DGND=0V, T_a=25\text{ }^\circ\text{C}$

Signal	Symbol	Parameter	MIN	MAX	Unit	Description
DSI-CLK+/-	$2xUI_{INSTA}$	Double UI instantaneous	4	25	ns	
DSI-CLK+/-	UI_{INSTA} UI_{INSTB}	UI instantaneous halves	2	12.5	ns	$UI = UI_{INSTA} = UI_{INSTB}$
DSI-Dn+/-	t_{DS}	Data to clock setup time	0.15	-	UI	
DSI-Dn+/-	t_{DH}	Data to clock hold time	0.15	-	UI	

Mipi Interface- High Speed Mode Timing Characteristics

Reset Timing:

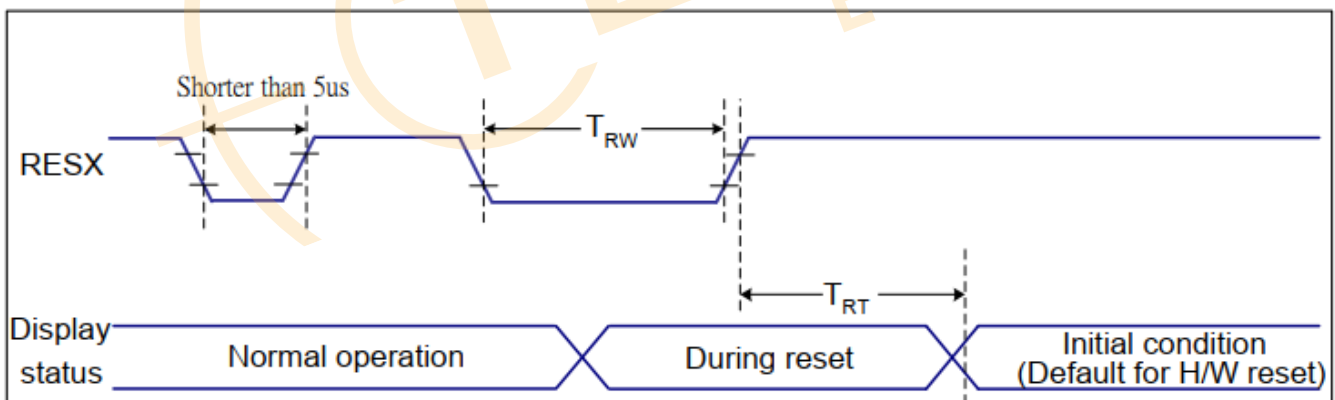

$VDDI=1.8, VDD=2.8, AGND=DGND=0V, T_a=25\text{ }^\circ\text{C}$

Related Pins	Symbol	Parameter	MIN	MAX	Unit
RESX	TRW	Reset pulse duration	10	-	us
	TRT	Reset cancel	-	5 (Note 1, 5)	ms
			-	120 (Note 1, 6, 7)	ms

5. Optical Specification

5.1 LCM Optical Characteristics

<Table 5. Optical Specifications>

[Ta=25±2°C]

Parameter		Symbol	Condition	Min.		Max.	Unit	Remark
Viewing Angle Range	Horizontal	Θ_3	CR > 10	80	85	-	Deg.	Note 4.1
		Θ_9		80	85	-	Deg.	
	Vertical	Θ_{12}		80	85	-	Deg.	
		Θ_6		80	85	-	Deg.	
Contrast Ratio			$\Theta = 0^\circ$	1000	1500	-		@Silicate BLU POL:HC+APF Note 4.2/4.3
Cell Transmittance		Tr		4.0	4.7	-	%	
Reproduction of color		Rx	$\Theta = 0^\circ$	0.629	0.649	0.669	-	CF@C Light Note 4.4
		Ry		0.294	0.314	0.334	-	
		Gx		0.243	0.263	0.283	-	
		Gy		0.542	0.562	0.582	-	
		Bx		0.117	0.137	0.157	-	
		By		0.091	0.111	0.131	-	
		Wx		0.275	0.295	0.315	-	
		Wy		0.311	0.331	0.351	-	
Color Gamut			$\Theta = 0^\circ$	60	65	-	%	
Response Time	Tr+Tf		Ta= 25° C $\Theta = 0^\circ$	-	30	40	ms	Note 4.5

5.2 Measurement system

5.2.1 LCM Viewing Angle

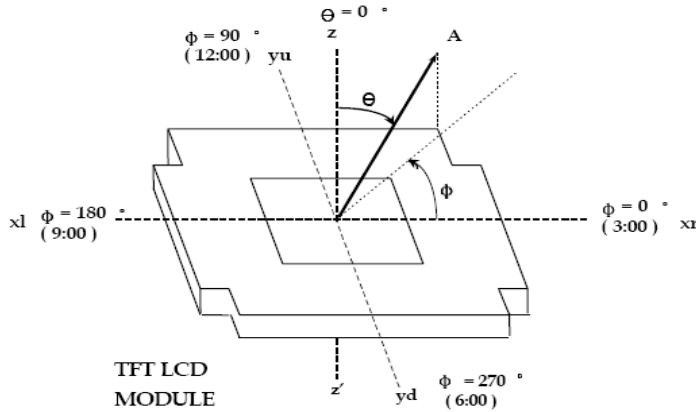

Viewing angle is the angle at which the contrast ratio is greater than 10. The angles are determined for the horizontal or x axis and the vertical or y axis with respect to the z axis which is normal to the LCD surface.

5.2.2 Response time

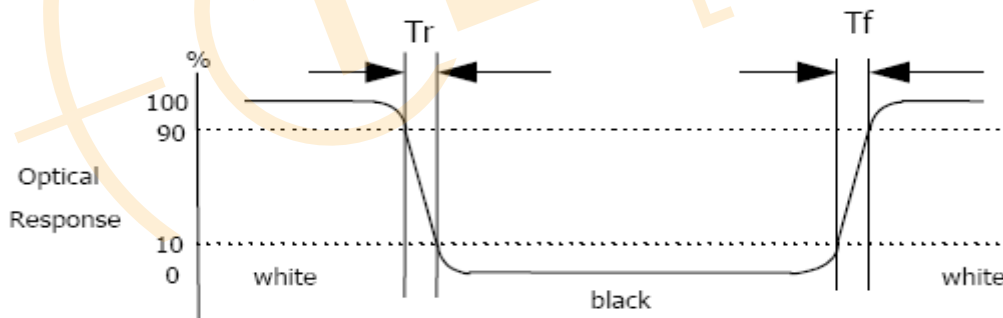

Response time is the time required for the display to transition from white to black (Rising time, T_r) and from black to white (Falling time, T_f) for additional information.

5.2.3 Contrast Ratio (CR)

Contrast Ratio (CR) is defined mathematically as:

$$\text{Contrast Ratio} = \frac{\text{Surface Luminance with all white pixels}}{\text{Surface Luminance with all black pixels}}$$

Surface luminance is the center point across the LCD surface 500mm from the surface with all pixels displaying white.



6.Mechanical Drawing

7. Reliability Test Items

Test Item	Test Condition	Test result determinant gist
High temperature storage	80±3°C , 48H ;	Inspection after 2~4hours storage at room temperature, the sample shall be free from defects: 1.Air bubble in the LCD; 2.Non-display; 3.Glass crack; 4. The electrical characteristics requirements shall be satisfied.
Low temperature storage	-30±3°C , 48H ;	
High temperature operation	70±3°C , 48H ;	
Low temperature operation	-20±3°C , 48H ;	
High temperature /humidity	60°C±3°C,90%±3%RH , 48H ;	
Thermal Shock	-20°C/0.5h~ +70°C/0.5h for a total 24 cycles ;	
Vibration Test	Frequency 10Hz~55Hz~10Hz Amplitude : 1.5mm, X , Y , Z direction for total 1H ; (Packing condition)	
ESD test	±2KV, Human Body Mode, 150pF/330Ω ; ±8KV, Air Mode, 150pF/330Ω ;	

9. Packing and Storage Specification

TBD

9.1. Storage Method

1. Store in an ambient temperature of $23^{\circ}\text{C}\pm 5^{\circ}\text{C}$, and in a relative humidity of $55\%\pm 1\%$. Don't exceed 12 months and expose to sunlight or fluorescent light.
2. Store in a clean environment, free from dust, active gas, and solvent.
3. Store in antistatic container.

10. Precautions

Please pay attention to the following when you use this TFT LCD module

10.1. Mounting Precautions

- (1) You must mount a module using arranged in four corners or four sides.
- (2) You should consider the mounting structure so that uneven force (ex. Twisted stress) is not applied to the module. And, the case on which a module is mounted should have sufficient strength so that external force is not transmitted directly to the module.
- (1) Please attach a transparent protective plate to the surface in order to protect the polarizer.
Transparent protective plate should have sufficient strength in order to the resist external force.

- (4) You should adopt radiation structure to satisfy the temperature specification.
- (5) Acetic acid type and chlorine type materials for the cover case are not describe because the former generates corrosive gas of attacking the polarizer at high temperature and the latter causes circuit break by electro-chemical reaction.
- (6) Do not touch, push or rub the exposed polarizer with glass, tweezers or anything harder than HB pencil lead. And please do not rub with dust clothes with chemical treatment. Do not touch the surface of polarizer for bare hand or greasy cloth. (Some cosmetics are determined to the polarizer)
- (7) When the surface becomes dusty, please wipe gently with adsorbent cotton or other soft materials like chamois soaks with petroleum benzene. Normal-hexane is recommended for cleaning the adhesives used to attach front / rear polarizer. Do not use acetone, toluene and alcohol because they cause chemical damage to the polarizer.
- (8) Wipe off saliva or water drops as soon as possible. Their long time contact with polarizer causes deformations and color fading.
- (9) Do not open the case because inside circuits do not have sufficient strength.

10.2 Operating Precautions

- (1) The spike noise causes the mis-operation of circuits. It should be lower than following voltage: $V=\pm 200\text{mV}$ (Over and under shoot voltage)
- (2) Response time depends on the temperature. (In lower temperature, it becomes longer.)
- (3) Brightness depends on the temperature. (In lower temperature, it becomes lower) And in lower temperature, response time (required time that brightness is stable after turned on) becomes longer.
- (2) Be careful for condensation at sudden temperature change. Condensation makes damage To polarizer or electrical contacted parts. And after fading condensation, smear or spot will occur.
- (5) When fixed patterns are displayed for a long time, remnant image is likely to occur. (6) Module has high frequency circuits. Sufficient suppression to the electromagnetic interference shall be done by system manufacturers. Grounding and Shielding methods may be important to minimize the interference.

10.3 Electrostatic Discharge Control

Since a module is composed of electronic circuits, it is not strong to electrostatic discharge. Make certain that treatment persons are connected to ground through wristband etc. And don't touch interface pin directly.

10.4 Precautions for Strong Light Exposure

Strong light exposure causes degradation of polarizer and color filter.

10.5 Storage

When storing modules as spares for a long time, the following precautions are necessary.

- (1) Store them in a dark place. Do not expose the module to sunlight or fluorescent light. Keep the temperature between 5°C and 35°C at normal humidity.
- (2) The polarizer surface should not come in contact with any other object. It is recommended that they be stored in the container in which they were shipped

10.6 Handling Precautions for protection film

- (1) When the protection film is peeled off, static electricity is generated between the film and polarizer. This should be peeled off slowly and carefully by people who are electrically grounded and with well ion-blown equipment or in such a condition, etc.
- (2) The protection film is attached to the polarizer with a small amount of glue. Is apt to remain on the polarizer. Please carefully peel off the protection film without rubbing it against the polarizer.
- (3) When the module with protection film attached is stored for a long time, sometimes there remains a very small amount of glue still on the polarizer after the protection film is peeled off.
- (4) You can remove the glue easily. When the glue remains on the polarizer surface or its vestige is recognized, please wipe them off with absorbent cotton waste or other soft material like chamois soaked with normal-hexane.

1.Scope 1适用范围

This document shall be applied to 0.95~5.0 TFT-LCD Panel.

本文件适用于0.95~5.0 TFT-LCD Panel.

2.Inspection and Environment onditions/检查条件与环境

2.1 Inspection Conditions 检查条件:

(1) Inspection Distance检测距离: 35 cm \pm 5cm

(2) Each picture /每个画面: 2~3 secs/秒, Cosmetic Insp./外观10~12 secs/秒

(3) View Angle观看角度:

Light-on Inspection Angle点灯检验角度 : $\pm 45^\circ$

Cosmetic Inspection Angle外观检验角度 : $\pm 45^\circ$

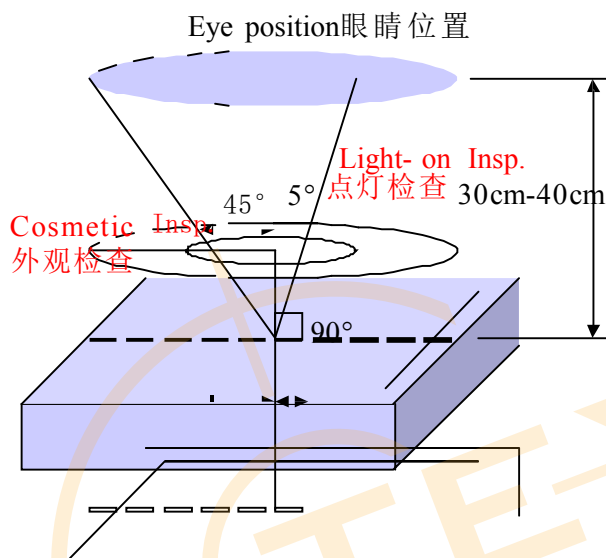

(Perpendicular to LCD panel surface垂直于液晶显示表面)

2.2 Environment Conditions环境条件:

Ambient Temperature 温度		25 $^\circ$ C \pm 5 $^\circ$ C
Ambient Humidity 湿度		55 \pm 5%RH
Ambient Illumination 亮度	Cosmetic Inspection 外观检验	800-1000 Lux
	Functional Inspection 点灯检验	200~300Lux

2.3 Sampling Conditions 抽样条件:

(1) Lot Size : Quantity of shipment lot per model/.

批量: 单次运送单一机型数量

- (2) Sampling Method :
抽样方法:

Sampling Plan 抽样计划		GB2828/2003
		Normal Inspection, Single Sampling 正常检验、单次抽样
		Geneal II Inspection 普通二级
AQL	Major Defect 主要缺点	0.25
	Minor Defect 次要缺点	0.65

- (3) The classification of Major(MA) and Minor(MI) defects is shown as 3. Inspection Criteria.
主缺(MA)及次缺(MI)定义于”3.检查标准”

3. Terms and Definitions/术语和定义

3.1 Classification of defects缺陷的分类:

Major defects: A major defect is a defect that is likely to result in failure, or to reduce materially the usability of the product for its intended purpose.

主要缺陷: 会导致产品功能失效或减少产品可用性的缺陷。

Minor defects: A minor defect either is a defect that is not likely to reduce materially the usability of the product for its intended purpose, or is a departure from an established having little bearing on the effective use or operation of the product.

次要缺陷: 不会导致产品功能失效, 不会减少产品的有效使用和操作。

- 3.2 Extraneous substances that can be wiped out ,like Finger point,Particles are not considered as a defect . 可以被擦拭干净的表面物质不视为缺陷 (如手指印, 尘粒) 。

- 3.3 Defects on the Black Matraix(outside of Active Area) are not considered as a defect . BM 区域 (AA 区以外) 的缺陷不视为缺陷。

- 3.4 Size of circular defect,is defined by diameter”D” 。 The defect average diameter $D=1/2(W+L)$ 圆形缺陷的大小是由直径 D 定义的。缺陷的平均直径 $D=1/2(W+L)$

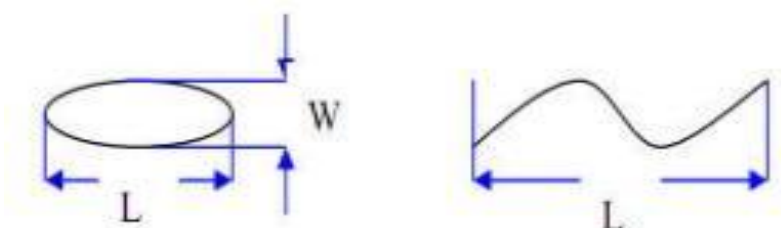

3.5 When defect size $L \geq 2W$, the defect count as liner type defect. Size of linear defect is defined by length(L) and the maximum width(W).

当缺陷尺寸 $L \geq 2W$ 时，被视为线状缺陷。线状缺陷是由长度 (L) 和最大宽度 (W) 定义的。3.6 Mura criteria :judged by ND filter 6%, and can't be seen under at ND filter 6% .

3.6 MURA 判断标准：使用 ND6% 判定，且透过 ND6%，遮住不可见。

3.7 Dot defect is defined as the defective area of the dot is larger than 50% of the dot area and is visible through 6% ND filter

DOT 定义为点缺陷面积大于 50% DOT 面积, 且透过 ND6% 遮住是可见的。

The drawing of 1/2 area sub-pixel definition: The 1/2 area sub-pixel can be defined as below one or more of specific shapes

1/2 面积的子像素定义绘图：1 / 2 面积的子像素可以定义为如下一个或多个特定形状图：



3.8 A dot defect that is smaller than the defined dot defect will be treated as small bright dot. 细碎亮点：小于“DOT 定义”的点缺陷视为细碎亮点。

I 区与 O 区比例：1： 2： 1

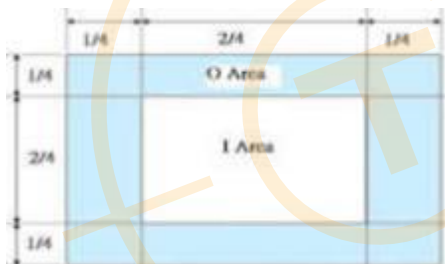

3.9 Inspection method of ND Filter - holding ND filter in front of the panel around 5cm and examine the panel from 35±5 cm in the front view for 2~3 second.

ND 卡的检查方法：在面板上方大约 5CM 处握住 ND 卡，眼睛距离面板 30-40CM，通过 2~3 秒观察。

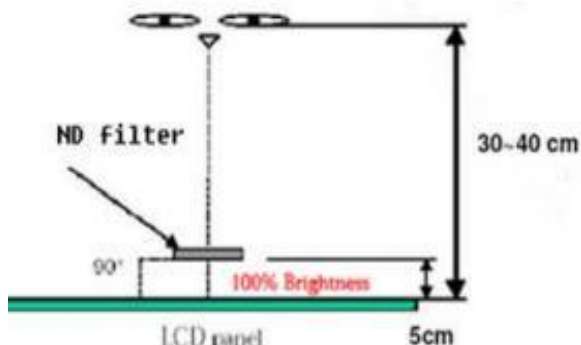

4. Inspection Criteria 检验标准

4.1 Appearance Inspection specification 外观检查规格:

Judge area 区域	Judge item 项目	Specification inspection 检查规格	Judge criterion	
			Major	Minor
Silicone 硅胶	Silicone spread 硅胶涂布	The height can't over C/F , color filter , or gomou 高度不能过超 C/F		MI
	Silicone residue 硅胶残余	Can't cover polarizer, FPC ...etc. 不能覆盖 POL, FPC 等		MI
LCD 玻璃	Wire(on Array) 线路	No damage 不能损伤	MA	
	Edge 边缘	No extended crack 不可有延伸性裂纹	MA	
PCBA Connector FPC/FFC	Appearance 外观	Scratch or damage result in copper expose is not allowed 划伤或损伤不允许导致出现露铜		MI
	Component 零件	No damage 不能损伤	MA	
	Connection status 连接状况	Need correct connection 需要正确连接	MA	
	Broken 破裂	Not allowable 不允许	MA	
	Folding sign 对位记号折叠	Not allowable 不允许	MA	
POL 偏光片	Scract on the polarizer 偏光片划伤	1. $W \leq 0.05\text{mm}$; $L \leq 5\text{mm}$, Ignore (忽略)		MI
		2. $0.05\text{mm} < W \leq 0.10\text{mm}$; $L \leq 5\text{mm}$; $N \leq 3$; $DS \geq 10\text{mm}$		
		3. $10\text{mm} < W$; $5\text{mm} < L$, Not allowable不允许		

Judge area 区域	Judge item 项目	Specification inspection 检查规格	Judge criterion	
			Major	Minor
POL 偏光片	Dent on the polarizer 偏光片凹痕	1.D<0.15mm, Ignore (忽略)		MI
		2.0.15mm<D≤0.30mm; N≤3; DS≥10mm		
		3.0.30mm<D, Not allowable不允许		
	POL Linear bubble 线状气泡	1.W≤0.05mm; L≤5mm, Ignore (忽略)		MI
		2.0.05mm<W≤0.10mm ; L≤5mm ; N≤3 ; DS≥10mm		
		3.0.10mm<W; 5mm< L , Not allowable不允许		
	POL dot bubble 点状气泡	1.D<0.15mm, Ignore (忽略)		MI
		2.0.15mm<D≤0.30mm; N≤3; DS≥10mm		
		3.0.30mm<D, Not allowable不允许		
	POL edge bubble 片边缘气泡	1. The display area is 1/2BM outside, Not allowable 显示区往外 1/2BM 区域内, 不允许 2. The display area is outside the outer 1/2BM area, Not allowable 显示区往外1/2BM区域以外, 不管控		MI

Judge area 区域	Judge item 项目	Specification inspection 检查规格	Judge criterion	
			Major	Minor
TP&CG	Foreign Material in spot shape 点状异物	1.D≤0.15mm; Ignored (忽略) 2.0.15mm<D≤0.30mm; N≤3; DS≥10mm 3.D>0.30mm; Not allowable不允许		MI
	Fisheye/bubbles 鱼眼/气泡	1.D≤0.15mm; Ignored (忽略) 2.0.15mm<D≤0.30mm; N≤3; DS≥10mm 3.D>0.30mm; Not allowable不允许		MI
	Scratches on the surface 表面划伤	1.W≤0.05mm; Ignored (忽略) 2.0.05mm<W≤0.10mm, L≤5mm; N≤3; DS≥10mm 3.W>0.10mm, L>5mm; Not allowable不允许		MI
	Collapse corner、Crash edge 崩角、崩边	Product front:/产品正面: collapse corners, collapsed edges are not allowed 崩角、崩边不允许; Product back/产品背面: X≤0.5, Y≤0.5, Z≤1/2T; N≤2; DS≥10mm	MA	
	Printed fonts/LOGO 丝印/LOGO	Printed fonts/LOGO clarity、complete、content right 字体/LOGO丝印清晰、完整、内容正确		MI
	Broken 破损	Not allowable不允许	MA	
	Dirty surfaces 表面脏污	Dirt cannot be wiped, Not allowable 不可擦拭的脏污, 不允许		MI
	IR hole IR孔	Black spots/黑点: W ≤0.15mm, N≤2, Not visible against a black background/黑色背景下不可见		MI
IR hole Scratches: 1.W<0.03mm, Ignored (忽略) (Dense points Not allowable 不允许密集); 2.0.03mm<W≤0.08mm; L≤2mm; N≤2; 3.W>0.08mm, L>2mm, Not allowable 不允许			MI	

4.2 Electrical Inspection specification 电性检查规格:

Item 项目	Judgment Criteria 判定标准	Judge criterion	
		Major	Minor
LCD Bright /Dark dot 玻璃亮点/暗点	1.D \leq 0.15mm, Ignored (忽略), Not dense (不可密集) 2.0.15mm<D \leq 0.30mm; N \leq 3; DS \geq 10mm 3.D>0.30mm, Not allowed/不允许		MI
Mura	Invisible through 6% ND filter, 200~300Lux 透过ND6% 遮住, 目测不可见即为OK, 200~300Lux		MI
Small bright dot 细碎亮点	Not allowed if it can be observed through ND Filter6% 透过ND6%目测看得见, 不允许		MI
ZBD Rate 玻璃亮点比率	90:10		MI
Light Leakage 漏光	Invisible through 6% ND filter, OK 透过ND6%遮住目测不可见即为OK If necessary,set up set up Limit Sample. 如果有必要, 可制订限度样品		MI
Bubble in Cell (LC Bubble/Actice Area) CELL气泡 (AA区LCD气泡)	Eyes should not find it . 目视观察不可见, 视为 OK	MA	

Item 项目	Judgment Criteria 判定标准	Judge criterion	
		Major	Minor
Foreign Material in spot shape 点状异物	1. $D \leq 0.15\text{mm}$, Ignored (忽略) 2. $0.15\text{mm} < D \leq 0.30\text{mm}$; $N \leq 3$; $DS \geq 10\text{mm}$ 3. $D > 0.30\text{mm}$, Not allowable/不允许		MI
Foreign Material in line or spiral shape 线状异物	1. $W \leq 0.05\text{mm}$, Ignored (忽略) 2. $L \leq 5\text{mm}$; $0.05\text{mm} < W \leq 0.10\text{mm}$; $N \leq 3$ 3. $W > 0.10\text{mm}$; $L > 5\text{mm}$, Not allowable/不允许		MI
White dot in back-light 白点	1. $D \leq 0.15\text{mm}$, Ignored (忽略) 2. $0.15\text{mm} < D \leq 0.30\text{mm}$; $N \leq 3$; $DS \geq 10\text{mm}$ 3. $D > 0.30\text{mm}$, Not allowed/不允许		MI
TP no touch 无触摸	Not allowable 不允许	MA	
Abnormal Display 显示异常	Not Allowed 不允许	MA	
NO display 无显示	Not Allowed 不允许	MA	
Line Defect 缺线	Not Allowed 不允许	MA	
Angle of view error 视角错误	Not Allowed 不允许	MA	
Tect crosstalk 不消失的残影	Not Allowed 不允许	MA	

Disclaimer

ALL PRODUCTS, PRODUCT SPECIFICATIONS AND DATA ARE SUBJECT TO CHANGE WITHOUT NOTICE TO IMPROVE RELIABILITY, FUNCTION OR DESIGN OR OTHERWISE.

Texim Europe B.V. its affiliates, agents, and employees, and all persons acting on its or their behalf (collectively, "Texim"), disclaim any and all liability for any errors, inaccuracies or incompleteness contained in any datasheet or in any other disclosure relating to any product.

Texim makes no warranty, representation or guarantee regarding the suitability of the products for any particular purpose or the continuing production of any product.

It is the customer's responsibility to validate that a particular product with the properties described in the product specification is suitable for use in a particular application.

Parameters provided in datasheets and / or specifications may vary in different applications and performance may vary over time.

All operating parameters, including typical parameters, must be validated for each customer application by the customer's technical experts.

Please contact us if you have any questions about the contents of the datasheet.

This may not be the latest version of the datasheet. Please check with us if a later version is available.

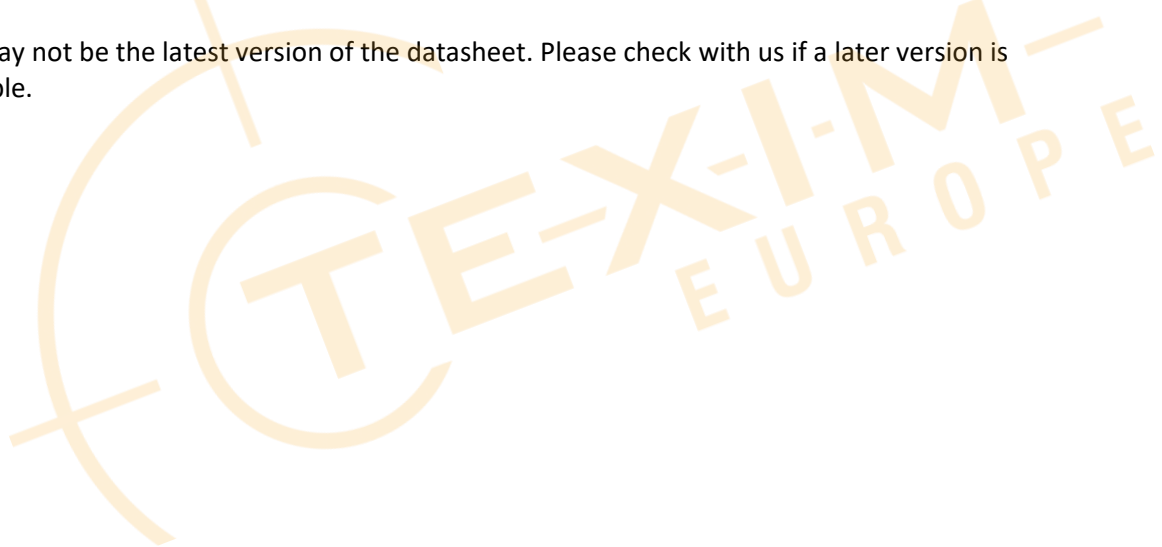



Headquarters & Warehouse

Elektrostraat 17
NL-7483 PG Haaksbergen
The Netherlands

T: +31 (0)53 573 33 33
E: info@texim-europe.com
Homepage: www.texim-europe.com



The Netherlands

Elektrostraat 17
NL-7483 PG Haaksbergen

T: +31 (0)53 573 33 33
E: nl@texim-europe.com



Belgium

Zuiderlaan 14, box 10
B-1731 Zellik

T: +32 (0)2 462 01 00
E: belgium@texim-europe.com



UK & Ireland

St Mary's House, Church Lane
Carlton Le Moorland
Lincoln LN5 9HS

T: +44 (0)1522 789 555
E: uk@texim-europe.com



Germany - North

Bahnhofstrasse 92
D-25451 Quickborn

T: +49 (0)4106 627 07-0
E: germany@texim-europe.com



Germany - South

Martin-Kollar-Strasse 9
D-81829 München

T: +49 (0)89 436 086-0
E: muenchen@texim-europe.com



Austria

Warwitzstrasse 9
A-5020 Salzburg

T: +43 (0)662 216 026
E: austria@texim-europe.com



Nordic

Stockholmsgade 45
2100 Copenhagen

T: +45 88 20 26 30
E: nordic@texim-europe.com



Italy

Martin-Kollar-Strasse 9
D-81829 München

T: +49 (0)89 436 086-0
E: italy@texim-europe.com