

# PRODUCT SPECIFICATION

<b>Part Number</b>	USB4750	<b>Rev</b>	A	<b>Date</b>	09/01/25		
<b>Product Description</b>	Type C Receptacle, Vertical, Top Mount, Through Hole, IP67, For Power Charging Only, 6Pin			<b>Page</b>	1		
<b>Doc Number</b>	USB Type C	<b>Prepared</b>	YR	<b>Checked</b>	CC	<b>Approved</b>	PH

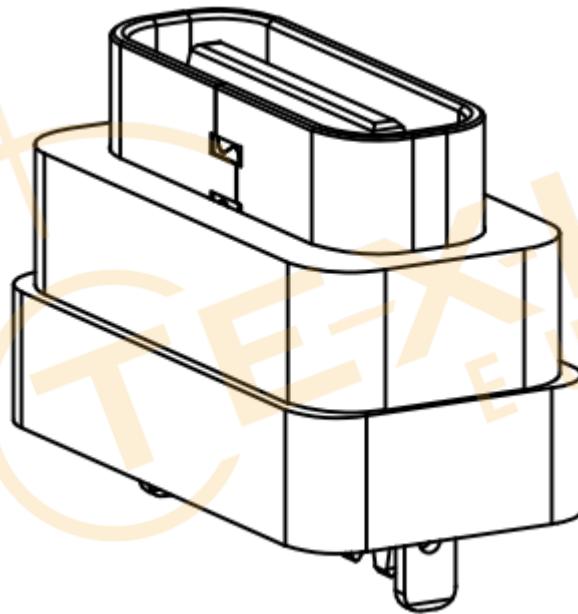

# PRODUCT SPECIFICATION

<b>Part Number</b>	USB4750	<b>Rev</b>	A	<b>Date</b>	09/01/25		
<b>Product Description</b>	Type C Receptacle, Vertical, Top Mount, Through Hole, IP67, For Power Charging Only, 6Pin			<b>Page</b>	2		
<b>Doc Number</b>	USB Type C	<b>Prepared</b>	YR	<b>Checked</b>	CC	<b>Approved</b>	PH

## 1.0 SCOPE

This specification covers performance, tests and quality requirements for the USB Type C Receptacle USB4750.

## 2.0 PRODUCT NAME AND PART NUMBER

USB Type C Receptacle USB4750

## 3.0 PRODUCT SHAPE, DIMENSIONS AND MATERIAL

Please refer to drawing.

## 4.0 RATINGS

4.1 Current rating: 3.00A collectively for VBUS pins (i.e., pins A9, B9)

4.25A collectively for GND pins (i.e., pins A12, B12)

1.25A for VCONN (i.e., A5/B5)

4.2 Voltage rating ..... 48V DC

4.3 Operating Temperature Range ..... -25°C to +85°C

## 5.0 TEST AND MEASUREMENT CONDITIONS

Product is designed to meet electrical, mechanical and environmental performance requirements specified below. All tests are performed in ambient conditions unless otherwise specified.

## 6.0 PERFORMANCE

Test No	Item	Test Condition	Requirement
6.0.1	Examination of Product	Visual, dimensional and functional inspection as per quality plan.	Product shall meet requirements of product drawing and specification.
	Reseating	Manually plug/unplug 3 times	No physical damage

# PRODUCT SPECIFICATION

<b>Part Number</b>	USB4750	<b>Rev</b>	A	<b>Date</b>	09/01/25		
<b>Product Description</b>	Type C Receptacle, Vertical, Top Mount, Through Hole, IP67, For Power Charging Only, 6Pin			<b>Page</b>	3		
<b>Doc Number</b>	USB Type C	<b>Prepared</b>	YR	<b>Checked</b>	CC	<b>Approved</b>	PH

## 6.1 Electrical Performance

Test No	Item	Test Condition	Requirement
6.1.1	Low Level Contact Resistance	The low level contact resistance measurement is made from the solder tail of the receptacle to the soldering point of the plug. When measured at 20mV Max. open circuit at 100mA. Mated test contacts must be in a connector housing. In accordance with EIA-364-23, Test Condition B	40mΩ max (initial)
6.1.2	Insulation Resistance	Both unmated and Mated connectors, apply 100V DC for 1 minute at sea level between adjacent terminal or ground. In accordance with EIA-364-21.	100 MΩ Min (initial)
6.1.3	Dielectric Strength	Mate connectors, apply 100V AC (RMS) for 1 minute at sea level. In accordance with EIA-364-20.	No Breakdown
6.1.4	Contact current rating	A current of 3 A shall be applied collectively to VBUS pins (i.e., pins A9, B9) and 1.25 A shall be applied to the VCONN pin (i.e., B5) as applicable, terminated through the corresponding GND pins (i.e., pins A12, B12). A minimum current of 0.25 A shall also be applied individually to all the other contacts, as applicable.	The temperature rise shall not exceed 30°C at the outside surface of the shell.

## 6.2 Mechanical Performance

Test No	Item	Test Condition	Requirement
6.2.1	Mating/Un-mating Force	Mate/Un-mated at a speed of 12.5mm/min. In accordance with EIA-364-13.	Mating force: within 5N to 20N (initial). Un-Mating force: within 8N to 20N up to 30cycles, within 6N to 20N after 20,000cycles
6.2.2	Durability	20,000 cycles at a cycle rate 500± 50per hour. In accordance with EIA-364-09. (Replace the plug after 10K cycles)	Un-Mating force: within 6N to 20N Contact resistance: 50mΩ max Dielectric Strength: no breakdown
	Durability (Preconditioning)	50 cycles at a cycle rate 500± 50 per hour In accordance with EIA-364-09.	-

# PRODUCT SPECIFICATION

<b>Part Number</b>	USB4750	<b>Rev</b>	A	<b>Date</b>	09/01/25		
<b>Product Description</b>	Type C Receptacle, Vertical, Top Mount, Through Hole, IP67, For Power Charging Only, 6Pin			<b>Page</b>	4		
<b>Doc Number</b>	USB Type C	<b>Prepared</b>	YR	<b>Checked</b>	CC	<b>Approved</b>	PH

6.2.3	Vibration	EIA 364-28 Test Condition VII, Test Letter D 15 minutes in each of 3 mutually perpendicular directions. Both mating halves should be rigidly fixed so as not to contribute to the relative motion of one contact against another. The method of fixturing should be detailed in the test report	No evidence of physical damage and no discontinuity longer than 1 microsecond. Contact resistance: 50mΩ max.
6.2.4	4-Axis Continuity	Shall be tested for continuity under stress using a test fixture	No evidence of physical damage and no discontinuity longer than 1 microsecond.

## 6.3 Environmental Performance and Others

Test No	Item	Test Condition	Requirement
6.3.1	Cyclic Temperature and Humidity Test	Cycle the connector between 25 °C ±3 °C at 80 % ±3% RH and 65 °C ±3 °C at 50 % ±3% RH. Ramp times should be 0.5 hour and dwell times should be 1.0 hour. Dwell times start when the temperature and humidity have stabilized within the specified levels. Perform 24 such cycles.	Contact Resistance: 50mΩ Max.
6.3.2	Salt Spray	Subject mated connectors to 5±1% salt-solution concentration, 35±2°C for 24 hours. In accordance with EIA-364-26, Test Condition B.	Shall meet visual requirements, no detrimental corrosion allowed in contact area and base metal exposed.
6.3.3	Thermal Shock	Temperature range from -55°C~+85°C. Start from -55°C. After 30 min. change to +85°C, change time is no more than 5min. Total 10 cycles. Test reference standard: EIA 364-32, test condition I	No physical damage. Contact Resistance (Low Level) 50m max.
6.3.4	Solderability	Solder pot temperature: 250±5°C for 3~5 seconds. In accordance with EIA-364-52.	95% of immersed area must show no voids, pin holes.
6.3.5	Temperature life	105° C without applied voltage for 120 hours. EIA-364-17, method A	Contact resistance: 50mΩ max
	Temperature Life (preconditioning)	105° C without applied voltage for 72 hours. EIA-364-17, method A	-

# PRODUCT SPECIFICATION

<b>Part Number</b>	USB4750	<b>Rev</b>	A	<b>Date</b>	09/01/25		
<b>Product Description</b>	Type C Receptacle, Vertical, Top Mount, Through Hole, IP67, For Power Charging Only, 6Pin			<b>Page</b>	5		
<b>Doc Number</b>	USB Type C	<b>Prepared</b>	YR	<b>Checked</b>	CC	<b>Approved</b>	PH

6.3.6	Mixed flowing gas	<p>Samples should be placed in an environmentally controlled 'test chamber' that is monitored by a gas analyzing system for controlled concentrations of the specified gas mixture. Test coupons shall also be used and the weight gain reported.</p> <p style="text-align: center;">Test duration is 7 days. EIA 364-65, Class II A</p>	Contact resistance: 50mΩ max
6.3.7	Thermal disturbance	<p>Cycle the connector or socket between 15 °C ±3 °C and 85 °C ± 3 °C, as measured on the part. Ramps should be a minimum of 2 °C per minute, and dwell times should insure that the contacts reach the temperature extremes (a minimum of 5 minutes). Humidity is not controlled. Perform 10 such cycles.</p>	Contact resistance: 50mΩ max
6.3.8	Waterproof Test	<p>Immerse the sample that be mounted in the specified enclosure in water as following conditions: Water depth:1m, Time:30 minutes In accordance with IEC60529:2013</p>	No leakage, water seepage, no obvious water mark in the test fixture.
6.3.9	Dust-tight Test	<p>Put sample in a closed chamber with suspended talcum powder as following conditions: Pump speed:40-60 times of the shell volume per hour Amount of talcum powder:2kg/m<sup>3</sup> Time:2 hours In accordance with IEC60529:2013</p>	No ingress of dust

## 7.0 RESISTANCE TO INFRARED REFLOW SOLDERING HEAT

Parameter	Reference	Specification
Average temperature gradient in preheating		2.5°C/s
Soak time	$T_{soak}$	2-3 minutes
Time above 217°C	$T_1$	60 s
Time above 230°C	$T_2$	50 s
Time above 250°C	$T_3$	5 s
Peak temperature in reflow	$T_{peak}$	255°C(-0/+5°C)
Temperature gradient in cooling		-5°C/s max

# PRODUCT SPECIFICATION

<b>Part Number</b>	USB4750	<b>Rev</b>	A	<b>Date</b>	09/01/25
<b>Product Description</b>	Type C Receptacle, Vertical, Top Mount, Through Hole, IP67, For Power Charging Only, 6Pin			<b>Page</b>	6
<b>Doc Number</b>	USB Type C	<b>Prepared</b>	YR	<b>Checked</b>	CC
				<b>Approved</b>	PH

## Lead Free Process

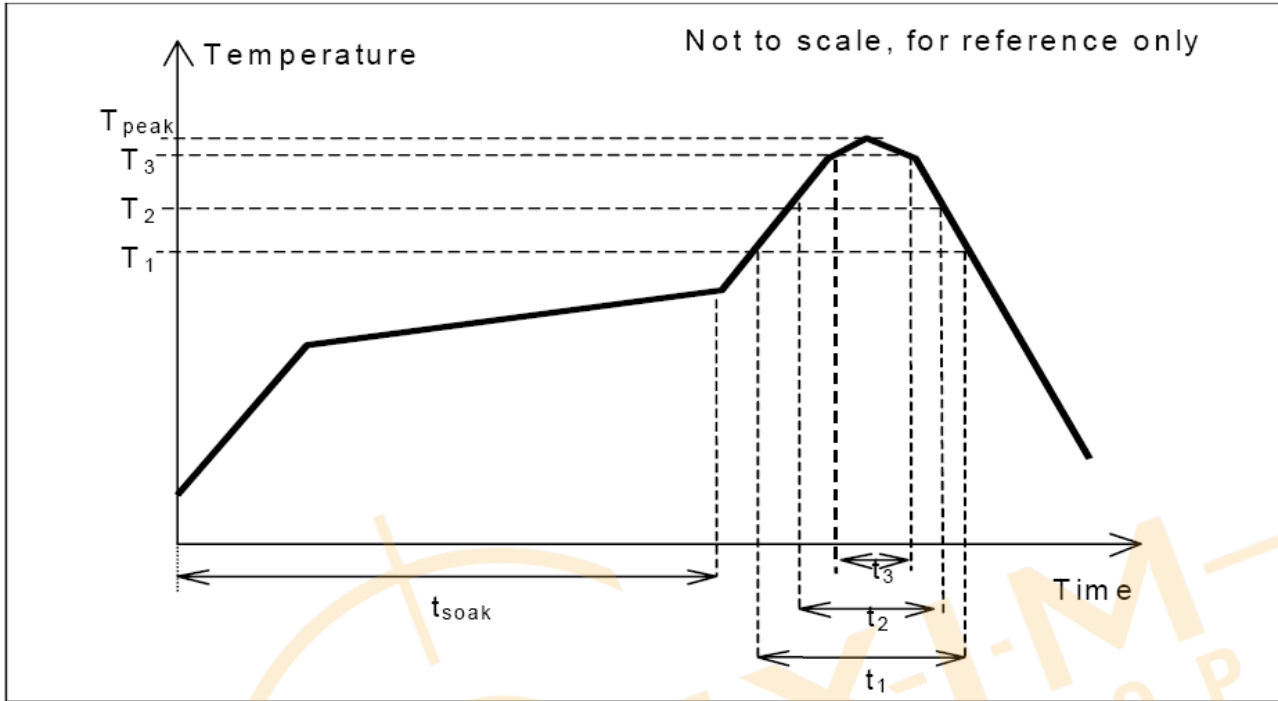

This profile is the minimum requirement for evaluating soldering heat resistance of components. Heat transfer method used for reflow soldering is hot air convection. The actual air temperatures used to achieve the specified profile is higher and largely dependent on the reflow equipment.

# PRODUCT SPECIFICATION

<b>Part Number</b>	USB4750	<b>Rev</b>	A	<b>Date</b>	09/01/25		
<b>Product Description</b>	Type C Receptacle, Vertical, Top Mount, Through Hole, IP67, For Power Charging Only, 6Pin			<b>Page</b>	7		
<b>Doc Number</b>	USB Type C	<b>Prepared</b>	YR	<b>Checked</b>	CC	<b>Approved</b>	PH

## 8.0 PACKAGING AND PRECAUTIONS

8.1 The product is packed in tape and reel, put into moisture barrier bag and vacuum sealed together with desiccant & humidity indicator.

8.2 Precautions:

MSL rating: 3

1. Recommended storage conditions before unpacking: +5°C to +30°C, maximum humidity 60%.
2. Recommended use within 168 hours after unpacking. For details, please refer to MSL label on packaging.
3. Connectors that have not been used up after 168 hours are suggested to be vacuum packed with desiccant. It is recommended that the parts are baked based on below process before reflow.
4. Baking process: remove tape and reel from vacuum sealed packaging and bake at 60°C ≤5% RH for 72 hours.
5. If floor life is not consistent with MSL rating 3 and above suggestions, air leakage performance post reflow will be impacted.

### Packaging process



# PRODUCT SPECIFICATION

<b>Part Number</b>	USB4750	<b>Rev</b>	A	<b>Date</b>	09/01/25
<b>Product Description</b>	Type C Receptacle, Vertical, Top Mount, Through Hole, IP67, For Power Charging Only, 6Pin			<b>Page</b>	8
<b>Doc Number</b>	USB Type C	<b>Prepared</b>	YR	<b>Checked</b>	CC
		<b>Approved</b>			PH

## Repackaging process

Unused connectors



Desiccant



Vacuum packed



## Baking process

Unpack



Baking oven

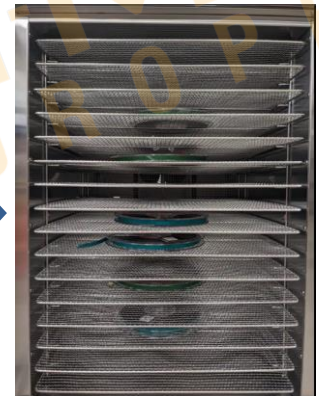

## 9.0 PRODUCT QUALIFICATION AND TEST SEQUENCE

Note: each group test needs 5pcs samples.

Test No	Description	Requirement
<b>Group A-1</b>		
6.0.1	Examination	Visual inspection; No physical damage
6.1.1	LLCR	40mΩ Max all contacts
6.2.2	Durability	50 cycles; No physical damage



# PRODUCT SPECIFICATION

<b>Part Number</b>	USB4750	<b>Rev</b>	A	<b>Date</b>	09/01/25		
<b>Product Description</b>	Type C Receptacle, Vertical, Top Mount, Through Hole, IP67, For Power Charging Only, 6Pin			<b>Page</b>	9		
<b>Doc Number</b>	USB Type C	<b>Prepared</b>	YR	<b>Checked</b>	CC	<b>Approved</b>	PH

	(preconditioning)	
6.3.5	Temperature Life	
6.1.1	LLCR	50mΩ Max all contacts
6.0.1	Reseating	No physical damage
6.1.1	LLCR	50mΩ Max all contacts
6.0.1	Examination	Visual inspection; No physical damage
<b>Group A-2</b>		
6.0.1	Examination	Visual inspection; No physical damage
6.1.1	LLCR	40mΩ Max all contacts
6.2.2	Durability (preconditioning)	50 cycles; No physical damage
6.3.3	Thermal Shock	
6.1.1	LLCR	50mΩ Max all contacts
6.3.1	Humidity	
6.1.1	LLCR	50mΩ Max all contacts
6.0.1	Reseating	No physical damage
6.1.1	LLCR	50mΩ Max all contacts
6.0.1	Examination	Visual inspection; No physical damage
<b>Group A-3</b>		
6.0.1	Examination	Visual inspection; No physical damage
6.1.1	LLCR	40mΩ Max all contacts
6.2.2	Durability (preconditioning)	50 cycles; No physical damage
6.3.5	Temperature Life (preconditioning)	
6.1.1	LLCR	50mΩ Max all contacts
6.2.3	Vibration	Discontinuity less than 1μs
6.1.1	LLCR	50mΩ Max all contacts
6.0.1	Examination	Visual inspection; No physical damage
<b>Group A-4</b>		

# PRODUCT SPECIFICATION

<b>Part Number</b>	USB4750	<b>Rev</b>	A	<b>Date</b>	09/01/25		
<b>Product Description</b>	Type C Receptacle, Vertical, Top Mount, Through Hole, IP67, For Power Charging Only, 6Pin			<b>Page</b>	10		
<b>Doc Number</b>	USB Type C	<b>Prepared</b>	YR	<b>Checked</b>	CC	<b>Approved</b>	PH

6.0.1	Examination	Visual inspection; No physical damage
6.1.1	LLCR	40mΩ Max all contacts
6.2.2	Durability (preconditioning)	50 cycles; No physical damage
6.3.5	Temperature Life (preconditioning)	
6.1.1	LLCR	50mΩ Max all contacts
6.3.6	Mixed Flowing Gases	
6.1.1	LLCR	50mΩ Max all contacts
6.3.7	Thermal Disturbance	
6.1.1	LLCR	50mΩ Max all contacts
6.0.1	Reseating	No physical damage
6.1.1	LLCR	50mΩ Max all contacts
6.0.1	Examination	Visual inspection; No physical damage
<b>Group A-7</b>		
6.0.1	Examination	Visual inspection; No physical damage
6.1.3	DWV	No breakdown or flashover
6.1.1	LLCR	40mΩ Max all contacts
6.2.2	Durability (preconditioning)	No physical damage
6.2.1	Insertion Force	Within the range of 5N to 20N.
6.2.1	Extraction force	Within the range of 8N to 20N. Initial Reading
6.2.2	Durability	25cycles, No physical damage
6.2.1	Extraction force	Within: a) 33% of initial reading & b) 8N to 20N
6.2.2	Durability	Perform 2468cycles and then rotate the plug or socket 180° and then perform 2500cycles. rotate the plug or socket 180° and then perform 2500cycles. rotate the plug or socket 180° and then perform 2500cycles. No physical damage (Replace the plug after 10K cycles)
6.2.1	Extraction force	Within the range of 6N to 20N.
6.1.1	LLCR	50mΩ Max all contacts
6.1.3	DWV	No breakdown or flashover

# PRODUCT SPECIFICATION

<b>Part Number</b>	USB4750	<b>Rev</b>	A	<b>Date</b>	09/01/25		
<b>Product Description</b>	Type C Receptacle, Vertical, Top Mount, Through Hole, IP67, For Power Charging Only, 6Pin			<b>Page</b>	11		
<b>Doc Number</b>	USB Type C	<b>Prepared</b>	YR	<b>Checked</b>	CC	<b>Approved</b>	PH

6.1.2	Insulation Resistance	100 MΩ Max.
6.0.1	Examination	Visual inspection; No physical damage
<b>Group B-1</b>		
6.0.1	Examination	Visual inspection; No physical damage
6.2.4	4-Axis Continuity	Discontinuity less than 1μs
6.0.1	Examination	Visual inspection; No physical damage
<b>Group B-6</b>		
6.0.1	Examination	Visual inspection; No physical damage
6.1.4	Contact Current Rating	The Temperature Rise shall not exceed 30°C
6.0.1	Examination	Visual inspection; No physical damage
<b>Group B-7</b>		
6.0.1	Examination	Visual inspection; No physical damage
6.3.8	Waterproof Test	No leakage, water seepage, no obvious water mark in the test fixture.
6.3.9	Dust-tight Test	No ingress of dust

# PRODUCT SPECIFICATION

<b>Part Number</b>	USB4750	<b>Rev</b>	A	<b>Date</b>	09/01/25		
<b>Product Description</b>	Type C Receptacle, Vertical, Top Mount, Through Hole, IP67, For Power Charging Only, 6Pin			<b>Page</b>	12		
<b>Doc Number</b>	USB Type C	<b>Prepared</b>	YR	<b>Checked</b>	CC	<b>Approved</b>	PH

## Revision Details:

Revision	Information	Page	Release Date
0.1	First draft for review	-	06/01/2025
A	First Release	-	09/01/2025



## **Disclaimer**

ALL PRODUCTS, PRODUCT SPECIFICATIONS AND DATA ARE SUBJECT TO CHANGE WITHOUT NOTICE TO IMPROVE RELIABILITY, FUNCTION OR DESIGN OR OTHERWISE.

Texim Europe B.V. its affiliates, agents, and employees, and all persons acting on its or their behalf (collectively, "Texim"), disclaim any and all liability for any errors, inaccuracies or incompleteness contained in any datasheet or in any other disclosure relating to any product.

Texim makes no warranty, representation or guarantee regarding the suitability of the products for any particular purpose or the continuing production of any product.

It is the customer's responsibility to validate that a particular product with the properties described in the product specification is suitable for use in a particular application.

Parameters provided in datasheets and / or specifications may vary in different applications and performance may vary over time.

All operating parameters, including typical parameters, must be validated for each customer application by the customer's technical experts.

Please contact us if you have any questions about the contents of the datasheet.

This may not be the latest version of the datasheet. Please check with us if a later version is available.

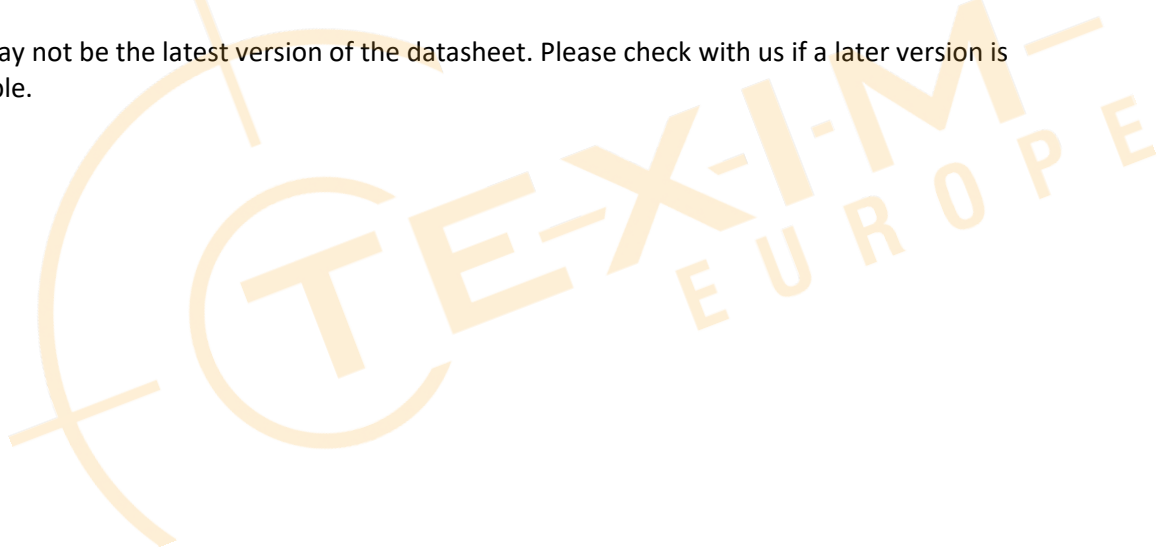



## Headquarters & Warehouse

Elektrostraat 17  
 NL-7483 PG Haaksbergen  
 The Netherlands

T: +31 (0)53 573 33 33  
 E: info@texim-europe.com  
 Homepage: www.texim-europe.com



### The Netherlands

Elektrostraat 17  
 NL-7483 PG Haaksbergen

T: +31 (0)53 573 33 33  
 E: nl@texim-europe.com



### Belgium

Zuiderlaan 14, box 10  
 B-1731 Zellik

T: +32 (0)2 462 01 00  
 E: belgium@texim-europe.com



### UK & Ireland

St Mary's House, Church Lane  
 Carlton Le Moorland  
 Lincoln LN5 9HS

T: +44 (0)1522 789 555  
 E: uk@texim-europe.com



### Germany - North

Bahnhofstrasse 92  
 D-25451 Quickborn

T: +49 (0)4106 627 07-0  
 E: germany@texim-europe.com



### Germany - South

Martin-Kollar-Strasse 9  
 D-81829 München

T: +49 (0)89 436 086-0  
 E: muenchen@texim-europe.com



### Austria

Warwitzstrasse 9  
 A-5020 Salzburg

T: +43 (0)662 216 026  
 E: austria@texim-europe.com



### Nordic

Stockholmsgade 45  
 2100 Copenhagen

T: +45 88 20 26 30  
 E: nordic@texim-europe.com



### Italy

Martin-Kollar-Strasse 9  
 D-81829 München

T: +49 (0)89 436 086-0  
 E: italy@texim-europe.com