



HDMI TFT Module Specification

MODEL: HA-215HVEE0GB0-AA

- <◆> PRELIMINARY SPECIFICATION
- <◇> APPROVAL SPECIFICATION

CUSTOMER
APPROVED BY
DATE:

DESIGNED	CHECKED	APPROVED
		

RECORD OF REVISION

Version	Revised Date	Page	Content
V1.0	2021/10/29	--	First Issued
V1.1	2021/11/03	5	MECHANICAL SPECIFICATION
		6	Add LINE OUT 1 and LINE OUT 2
		8	BLOCK DIAGRAM



TABLE OF CONTENTS

No.	Content	Page
	HDMI TFT Module Specification	1
	TABLE OF CONTENTS	3
1.	GENERAL DESCRIPTION	4
2.	MECHANICAL SPECIFICATION	5
3.	PIN DESCRIPTION	6
4.	ABSOLUTE MAXIMUM RATINGS	7
5.	BLOCK DIAGRAM	8
6.	ELECTRICAL CHARACTERISTICS	9
7.	OPTICAL CHARACTERISTICS	10
8.	RELIABILITY	13
9.	PRECAUTION RELATING PRODUCT HANDLING	20



1. GENERAL DESCRIPTION
1.1 Description

HA-215HVEE0GB0-AA is a 21.5 (16:10) inch diagonally measured active display with high resolution 1920x1080 display. This model is composed of a TFT LCD panel, backlight system and HDMI included Stereo D/A Converter . It is designed to make Raspberry Pi usage easy. You can simply use this TFT display with your Raspberry Pi, or also you can use this as computer display with any device which has HDMI output. This 21.5" TFT model comes in 1920x1080 resolution that would be great for embedded computing usage too.

1.2 Features:

No.	Item	Specification	Unit
1	Panel Size	21.5"	Inch
2	Number of Pixels	1920 (W) x RGB x 1080 (H)	Pixels
3	Active Area	476.064 (W) × 267.786 (H)	mm
4	Pixel Pitch	0.24795 (W) x 0. 24795 (H)	mm
5	Outline Dimension	497.6 (W) × 292.2 (H) × 24.2 (T)	mm
6	Number of Colors	16.7M	--
7	Display Mode	Normally Black	--
8	View Direction	Free direction	--
9	Display Format	RGB vertical stripe	--
10	Surface Treatment	Anti-Glare (3H)	--
11	Contrast Ratio	1000 (Typ.)	--
12	Luminance (cd/m ²)	500 (Typ.)	cd/m ²
13	Video Input Interface	HDMI (Compliance HDMI V1.4)	--
14	Audio Output Interface	Analog Output	--
15	Backlight	White LED	--
16	Operation Temperature	-10 ~ 60	°C
17	Storage Temperature	-20 ~ 60	°C
18	Weight	(TBD)	g

2. MECHANICAL SPECIFICATION

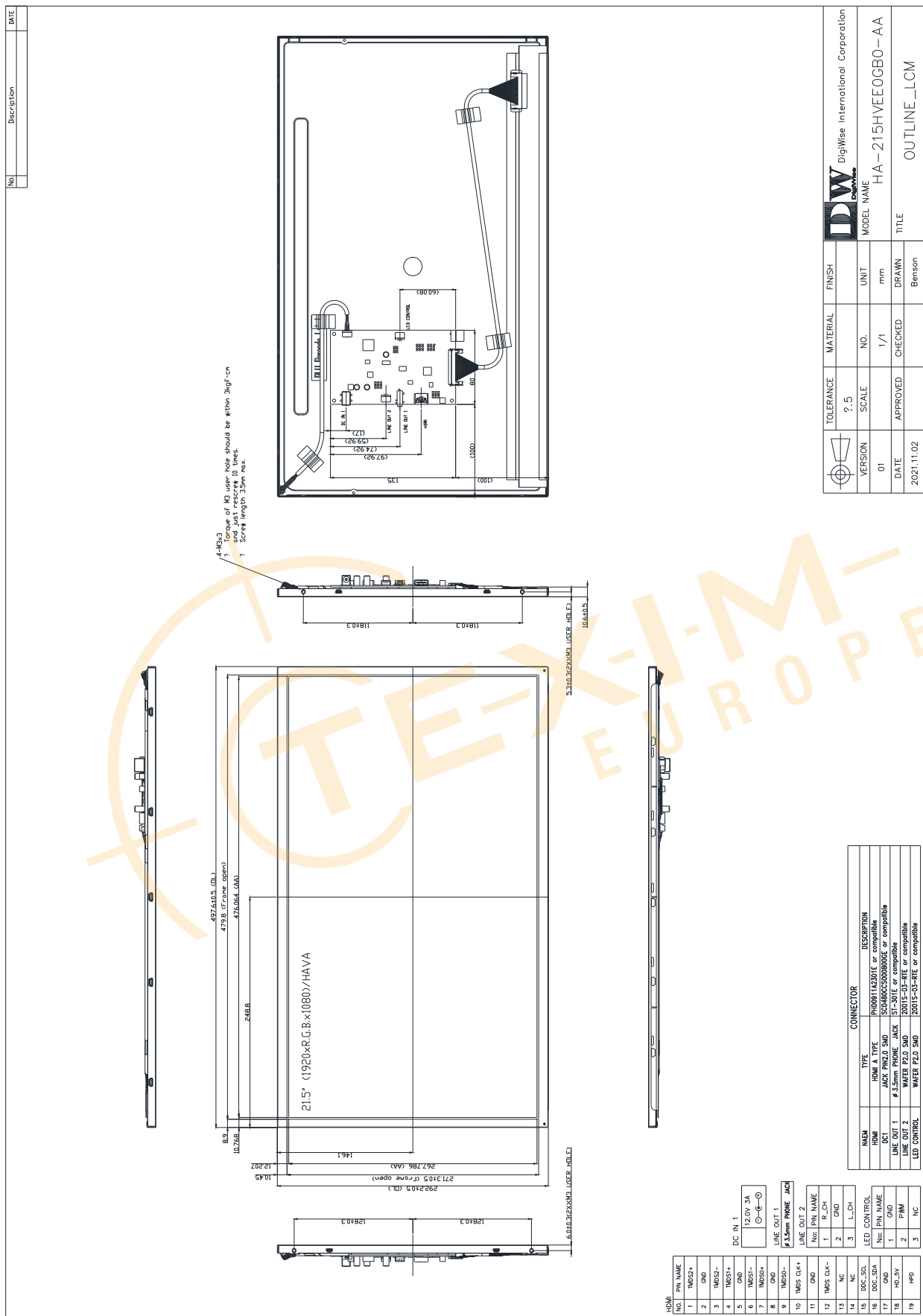

3. PIN DESCRIPTION

3.1 Power Input(DC1) [DC JACK:SCD480CCS000B00GE or compatible]

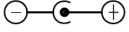
Pin No.	Symbol	I/O	Function	Note
1	12V	P	Power Supply +12V	12.0V 
2	GND	P	Ground	

3.2 Back-light Control(LED CONTROL) [WAFER P2.0mm:2001S-03-RTE or compatible]

Pin No.	Symbol	I/O	Function	Note
1	GND	P	Ground	
2	PWM	I	Back-light Dimming control (internal pull up to 3.3V)	*1
3	NC	I	No connection. (internal control)	

*1: When PWM not connected, back-light default is typical brightness.

3.3 Audio line out(LINE OUT 2) [WAFER P2.0mm:2001S-03-RTE or compatible]

Pin No.	Symbol	I/O	Function	Note
1	R_CH	A	HDMI Audio:Right Channel Analog Output	
2	GND	P	Ground	
3	L_CH	A	HDMI Audio:Left Channel Analog Output	

3.4 Standard 3.5mm Phone Jack (LINE OUT 1) [PHONE JACK:ST-301E or compatible]

HDMI Audio Analog Output

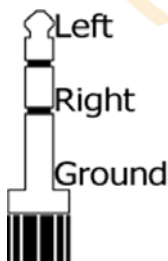

3.5 HDMI

[HDMI A TYPE:PHD0911A2301E or compatible]

Pin No.	Symbol	I/O	Function	Note
1	TMDS 2+	I	TMDS Data2+	
2	GND	P	TMDS Data2 Shield	
3	TMDS 2-	I	TMDS Data2-	
4	TMDS 1+	I	TMDS Data1+	
5	GND	P	TMDS Data1 Shield	
6	TMDS 1-	I	TMDS Data1-	
7	TMDS 0+	I	TMDS Data0+	
8	GND	P	TMDS Data0 Shield	
9	TMDS 0-	I	TMDS Data0-	
10	TMDS CLK+	I	TMDS Clock+	
11	GND	P	TMDS Clock Shield	
12	TMDS CLK-	I	TMDS Clock-	
13	N.C.	-	N.C.	
14	N.C.	-	N.C.	
15	DDC_SCL	I	IIC SCL to EDID ROM	
16	DDC_SDA	I/O	IIC SDA to EDID ROM	
17	GND	P	DDC/CEC Ground	
18	HD_5V	P	+5V Power	
19	HPD	O	Hot Plug Detect	

4. ABSOLUTE MAXIMUM RATINGS
4.1 Electrical Absolute Rating
4.1.1 HDMI TFT LCD Module

Item	Symbol	Values		Unit	Note
		Min	Max.		
Power supply voltage	12V	11	14	V	

4.1.2 Environment Absolute Rating

Item	Symbol	Values			Unit	Note
		Min	Typ	Max.		
Operating Temperature	Top	-10	-	60	°C	Ambient temperature
Storage Temperature	Tst	-20	-	60	°C	

5. BLOCK DIAGRAM

5.1 TFT LCD Module

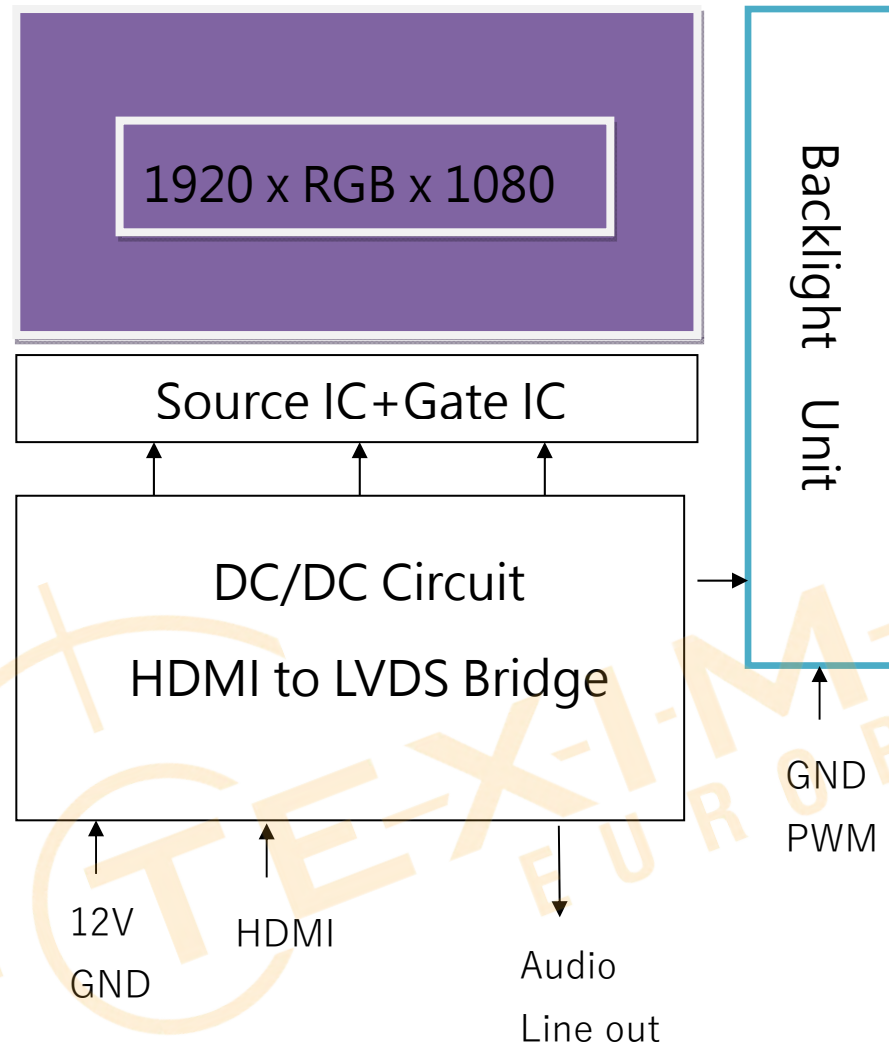

6. ELECTRICAL CHARACTERISTICS

6.1 HDMI TFT LCD Module

Item	Symbol	Values			Unit	Note
		Min	Typ.	Max.		
Supply Voltage	12V	11	12	13	V	
PWM frequency		100	-	10K	Hz	
PWM Duty		17	-	100	%	<17%=OFF
PWM Dimming Voltage	V _{PWM-IH}	3.3	-	8	V	
	V _{PWM-IL}	-	0.3	-	V	
LED Enable Control Voltage	V _{LED_EN-IH}	3.3	-	12	V	
	V _{LED_EN-IL}	-	-	0.5	V	
Supply Current	ICC(12V)	-	TBD	-	mA	
LED life time		30000	-	-	Hr	(1)

Note 1:

The "LED life time" is defined as the module brightness decrease to 50% original brightness that the ambient temperature is 25°C 60% RH.

7. OPTICAL CHARACTERISTICS

Item	Symbol	Condition	Min.	Typ.	Max.	Unit
Brightness	--	Note1, Note 3, ($\theta = 0^\circ$, Normal Viewing Angle)	400	500	--	cd/m ²
Uniformity	B-uni		(75)	--	--	%
Contrast Ratio	CR		800	1000	--	--
Response Time	Tr		--	12	22	ms
	Tf	--	10	20	ms	
Color Chromaticity	White	Wx	0.263	0.313	0.363	--
		Wy	0.279	0.329	0.379	--
View angle	Horizontal	$\theta x+$	80	89	--	
		$\theta x-$	80	89	--	
	Vertical	$\theta Y+$	80	89	--	
		$\theta Y-$	80	89	--	

Note : The following optical specifications shall be measured in a darkroom or equivalent state(ambient luminance ≤ 1 lux, and at room temperature). The operation temperature is $25^\circ\text{C} \pm 2^\circ\text{C}$. The measurement method is shown in Note1.

Note1: The method of optical measurement:

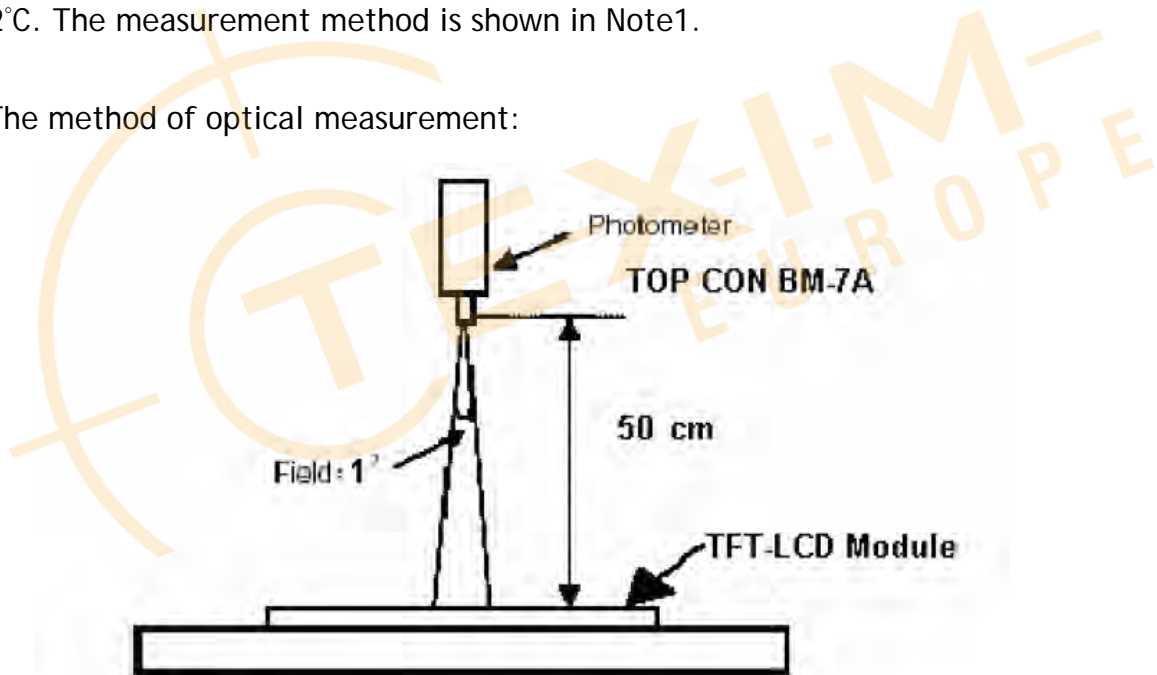

Note2: Measured at the center area of the panel and at the viewing angle of the $\theta x = \theta y = 0^\circ$

Note3: Definition of Contrast Ratio (CR):

CR = Luminance with all pixels in white state \div Luminance with all pixels in Black state

Note 4: Definition of Viewing Angle:

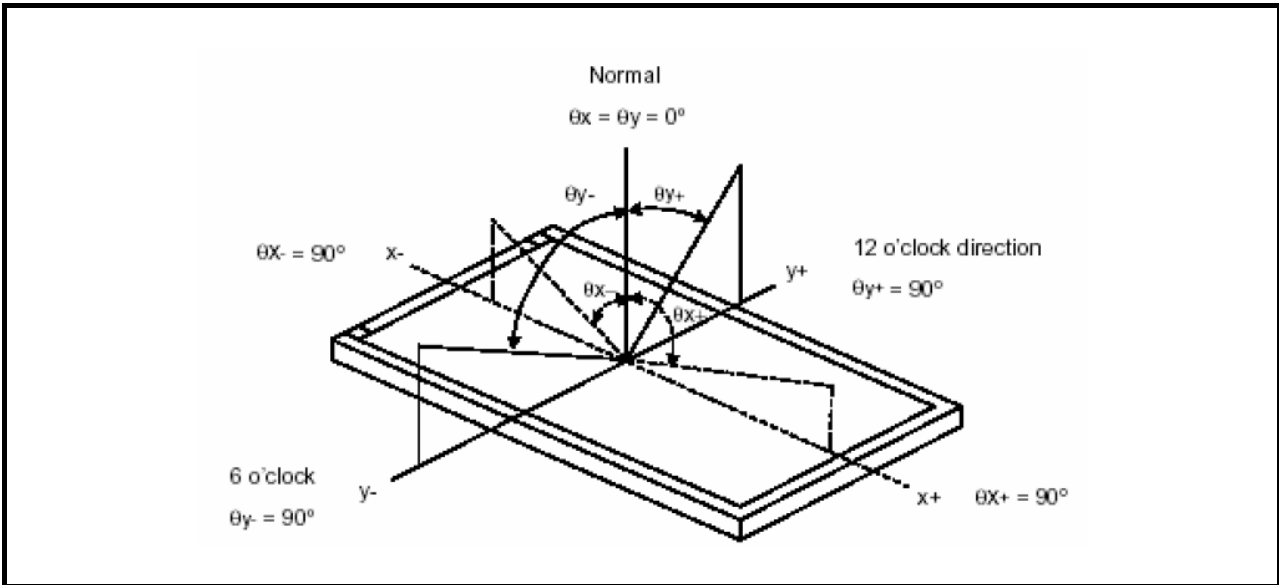

Note 5: Definition of Brightness Uniformity (B-uni):

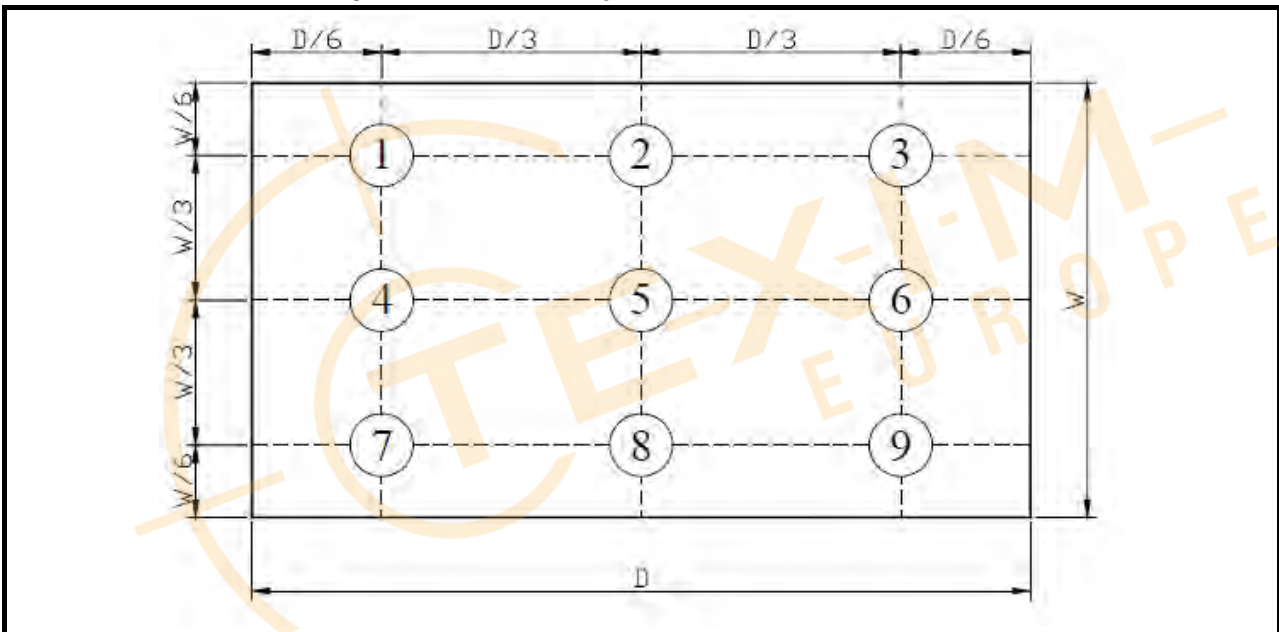

$$B\text{-uni} = (\text{Minimum luminance of 9 points} \div \text{Maximum luminance of 9 points}) \times 100\%$$

Note 6: Definition of Response Time:

The Response Time is set initially by defining the "Rising Time (T_r)" and the "Falling Time (T_f)" respectively. T_r and T_f are defined as following figure

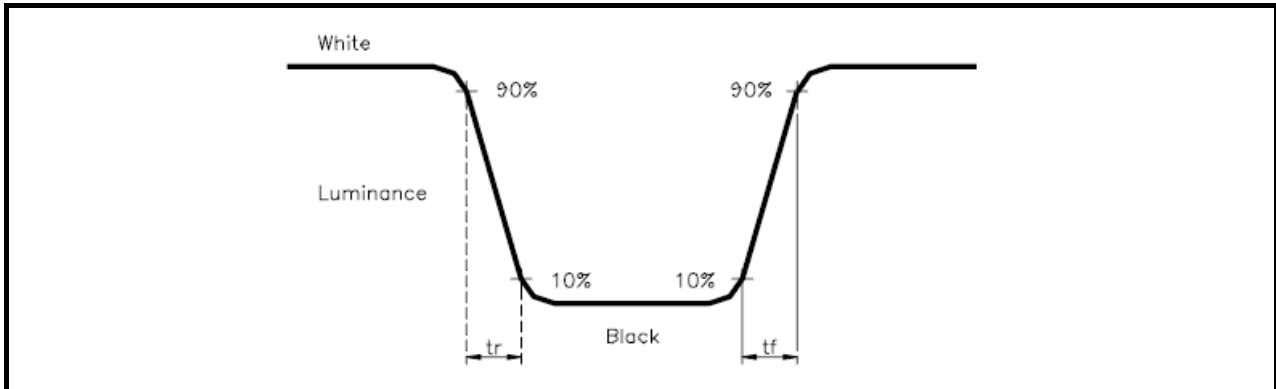

Note 7: Definition of Chromaticity:

The color coordinates (W_x, W_y), (R_x, R_y), (G_x, G_y), and (B_x, B_y) are obtained with all pixels in the viewing field at white, red, green, and blue states, respectively.



8. RELIABILITY

8.1 Test Condition

8.1.1 Temperature and Humidity(Ambient Temperature)

Temperature : 25 ± 5°C

Humidity : 65 ± 5%

8.1.2 Operation

Unless specified otherwise, test will be conducted under function state.

8.1.3 Container

Unless specified otherwise, vibration test will be conducted to the product itself without putting it in a container.

8.1.4 Test Frequency

In case of related to deterioration such as shock test. It will be conducted only once.

8.2 TESTS

No.	ITEM	CONDITION CRITERION
1	High Temperature Storage	60°C, 240 hrs
2	Low Temperature Storage	-20°C, 240 hrs
3	High Temperature Operating	60°C, 240 hrs
4	Low Temperature Operating	-10°C, 240 hrs
5	High Temperature/Humidity Non-Operating	60°C, 80%RH, 240 hrs
6	Temperature Shock Non-Operating	-20°C ↔ 60°C (0.5hr each), 100 cycles
7	Vibration Test Non-Operating	Acceleration: 1.5 G Wave:sine Frequency: 10 - 300 Hz Sweep: 30 Minutes each Axis (X, Y, Z)
8	Electro-static Discharge	Contact Discharge: ± 4KV,150pF(330Ω) Air Discharge: ± 8KV, 150pF(330Ω)

Note1: The test sample have recovery time for 24 hours at room temperature before the function check. In the standard conditions, there is no any touch panel function NG issue occurred.

8.3 JUDGMENT STANDARD

The judgment of the above test should be made as follow:

Pass: Normal display image with no obvious non-uniformity and no line defect. Partial transformation of the module parts should be ignored.

Fail: No display image, obvious non-uniformity, or line defects.



8.4 INCOMING INSPECTION STANDARDS

Inspection Item	Specification	
Line defect	Can't be seen.	
Bright dots	≤ 1 dots (note 1&2)	
Dark dots	≤ 5 dots	
Total dots defect	≤ 5 dots	
Continuous defect	Two continuous bright dots :	Not allowed
	Over three continuous bright dots (vertical, horizontal, oblique) :	Not allowed
	Two continuous dark dots (vertical, horizontal, oblique) :	≤ 2 pair
	Over three continuous dark dots (vertical, horizontal, oblique) :	Not allowed
	Two continuous dark dots and bright dots (vertical, horizontal, oblique) :	≤ 1 pair
	Over three continuous dots (vertical, horizontal, oblique) :	Not allowed
	Distance between 2 Bright dots :	≥ 15 mm
	Distance between 2 Dark dots :	≥ 15 mm
	Distance between Dark dot and Bright Dot :	≥ 15 mm
Mura	Use 5% ND filter or judged by equivalent limit sample (note 6)	

Note 1) For bright dot defect, bright area should be larger than 1/2 area of a sub-pixel to be count as 1 dot defect.

The bright dot defect must be visible through 5% ND filter.

Note 2) Judgment criteria (For Bright dot and Small Bright dot) : Using ND Filter 5% (distance : 30~40 cm). If it could be observed, dot defines as one bright dot. If not, dot defines as one small bright dot.

Small bright dot should be accepted if $N \leq 10$ which invisible through 5% ND filter.

The drawing of 1/2 area sub-pixel definition: The 1/2 area sub-pixel can be defined as below one or more of specific shapes (Fig.1).



Fig.1

Note 3) Adjacent-dot defect should be observed under the same display pattern in any one of Black/Green/Blue/Red pattern.

*Inspection pattern: Standard inspection patterns of dot defect are listed below. AU uses these patterns as standard criteria for judging dot defect. Please inform AU if any other pattern is to be used to examine dot defect.

Test Pattern	Defect
Full Black	For bright dot(s)
Full White	For dark dot(s)
Monotone Red /Green /Blue	For bright and dark dot(s)

Definition of two continuous bright dots: Only for two continuous dots (included vertical, horizontal, oblique type) (Fig.2)

Note 5) In three (or more) adjacent dot defect, for any 3rd dot that adjacent to 2 continuous defective dots (can be of any combination of bright dots and dark dots), the 3rd dot, no matter how large it may be, should be viewed as a dot.

Note 6) Defect criteria diagram

6-1) Adjacent Dot defect diagram:

Adjacent-dot defect : refer to Figure 2, dot 1,2,...,8 around A are all A's adjacent dots



Fig.2

6-2) Definition of distance between defect dots as following:

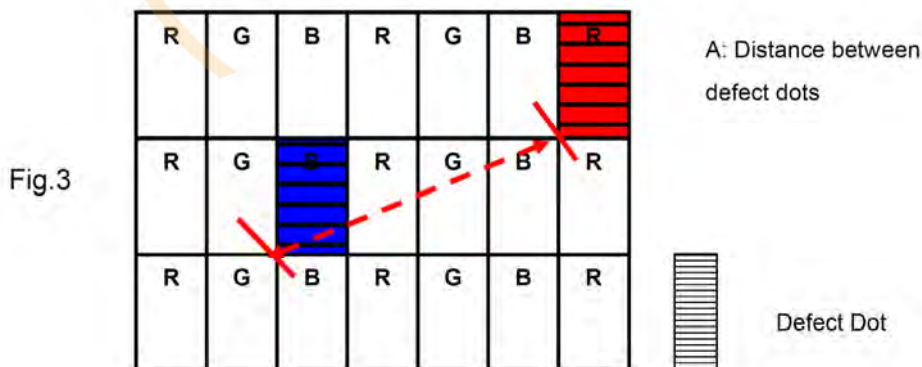

Fig.3

Note 7) Unless otherwise specified by written document or limit samples, Mura (display un-uniformity) should inspected under the ND filter and shall be accepted when it is invisible 5% ND filter is applied.

ND filter use method: The inspection method of ND Filter - holding ND filter in front of the panel around 5 cm and examine the panel from 35 ± 5 cm in the front view for 3 seconds. (Fig.4)

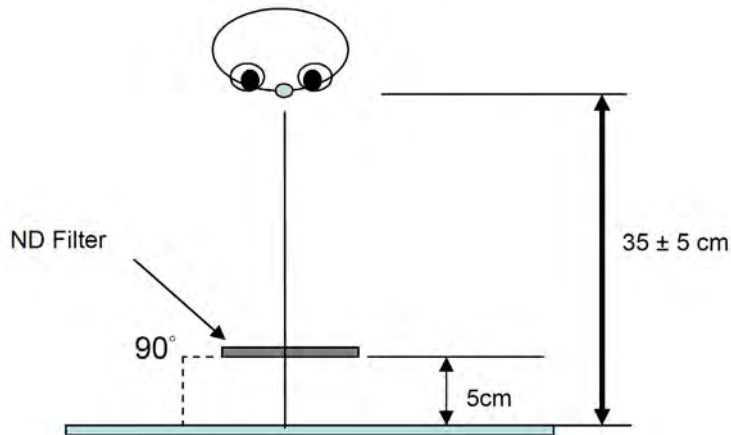

Fig.4

Note 8) While operating over 50°C ambient temperature , there should be no function failure occur and Mura (display un-uniformity) should be invisible under 1% ND filter applied.

Note 9) Image Retention : 5 seconds test pattern and image retention must be disappeared in 5 seconds after pattern changed .

8.5 Scratches, dent, extraneous substances and Appearance inspection specification

Judge area	Judge item		Inspection specification		Judge criterion	
					Major	Minor
Active area	Particles on the polarizer	Circular	Average diameter: D (mm)		Numbers	
			$D \leq 0.15$		Disregarded	
			$0.15 < D \leq 0.50$		$N \leq 4$	
			$0.50 < D$		$N = 0$	
		Linear	Width: W (mm) , Length: L (mm)		Numbers	
			$W \leq 0.07$	$L \leq 3.0$	Disregarded	
	Scratch/Dent on the polarizer	Circular	Average diameter: D (mm)		Numbers	
			$D \leq 0.15$		Disregarded	
			$0.15 < D \leq 0.50$		$N \leq 4$	
			$0.50 < D$		$N = 0$	
		Linear	Width: W (mm) , Length: L (mm)		Numbers	
			$W \leq 0.07$	$L \leq 3.0$	Disregarded	
Bubble on the polarizer	Circular	Average diameter: D (mm)		Numbers		
		$D \leq 0.15$		Disregarded		
		$0.15 < D \leq 0.50$		$N \leq 4$		
		$0.50 < D$		$N = 0$		
	Linear	Width: W (mm) , Length: L (mm)		Numbers		
		$W \leq 0.07$	$L \leq 3.0$	Disregarded		
Bezel	Gap between front and back bezel on all sides $\leq 2.0\text{mm}$					
	Scratches, Wrap and Sunken		No harm, dangerous			
	Assembly Fail		Not allowed			
Label (S/N, B/L, WEEK)	No label					
	Invert label		Not allowed			
	Content Error					
	Dirt					
	Not clear					
	Word out of shape					
	Broken		Word can be read. Barcode can be scanned.			
	Crease					
	Label overlapping					
Position		Be attached on right position				
Screw	Not enough (Q'ty)		Not allowed			
	Loose		Not allowed			
Connector	Appearance		No broken, rising, deformation			

Note 1 : Extraneous substances which can be wiped out, such as fingerprint and particles are not considered as a defect.

Note 2 : Defects on the Black Matrix (outside Active Area 0.3mm) are not considered as a defect.

Note 3 : Defect size definition: (Unit:mm)

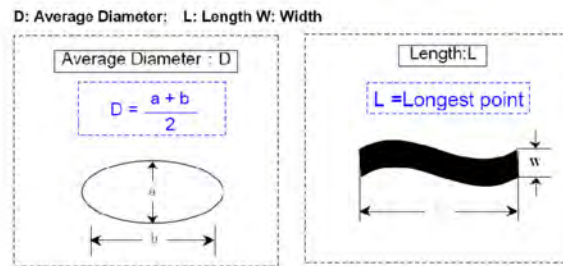

8.6 Inspection judgement

- (1) The judgement of the shipped lot (acceptance or rejection) should follow the sampling plan of ANSI/ASQL Z1.4-2003, single sampling, normal inspection, level II.
- (2) If the number of defects is equal to or less than the applicable acceptance level, the lot shall be accepted.
- (3) If the number of defects is more than the applicable acceptance level, the lot shall be rejected and the buyer should inform the seller of the result of incoming inspection in writing.



9. PRECAUTION RELATING PRODUCT HANDLING

9.1 SAFETY

- 9.1.1 If the LCD panel breaks , be careful not to get the liquid crystal to touch your skin.
- 9.1.2 If the liquid crystal touches your skin or clothes , please wash it off immediately by using soap and water.

9.2 HANDLING

- 9.2.1 Avoid any strong mechanical shock which can break the glass.
- 9.2.2 Avoid static electricity which can damage the CMOS LSI—When working with the module, be sure to ground your body and any electrical equipment you may be using.
- 9.2.3 Do not remove the panel or frame from the module.
- 9.2.4 The polarizing plate of the display is very fragile. So , please handle it very carefully, Do not touch, push or rub the exposed polarizing with anything harder than an HB pencil lead (glass , tweezers , etc.)
- 9.2.5 Do not wipe the polarizing plate with a dry cloth, as it may easily scratch the surface of plate.
- 9.2.6 Do not touch the display area with bare hands , this will stain the display area.
- 9.2.7 Do not use ketonics solvent & aromatic solvent. Use with a soft cloth soaked with a cleaning naphtha solvent.
- 9.2.8 To control temperature and time of soldering is $280 \pm 10^{\circ}\text{C}$ and 3-5 sec.
- 9.2.9 To avoid liquid (include organic solvent) stained on LCM.

9.3 STORAGE

- 9.3.1 Store the panel or module in a dark place where the temperature is $25^{\circ}\text{C} \pm 5^{\circ}\text{C}$ and the humidity is below 65% RH.
- 9.3.2 Do not place the module near organics solvents or corrosive gases.
- 9.3.3 Do not crush, shake, or jolt the module.

Disclaimer

ALL PRODUCTS, PRODUCT SPECIFICATIONS AND DATA ARE SUBJECT TO CHANGE WITHOUT NOTICE TO IMPROVE RELIABILITY, FUNCTION OR DESIGN OR OTHERWISE.

Texim Europe B.V. its affiliates, agents, and employees, and all persons acting on its or their behalf (collectively, "Texim"), disclaim any and all liability for any errors, inaccuracies or incompleteness contained in any datasheet or in any other disclosure relating to any product.

Texim makes no warranty, representation or guarantee regarding the suitability of the products for any particular purpose or the continuing production of any product.

It is the customer's responsibility to validate that a particular product with the properties described in the product specification is suitable for use in a particular application.

Parameters provided in datasheets and / or specifications may vary in different applications and performance may vary over time.

All operating parameters, including typical parameters, must be validated for each customer application by the customer's technical experts.

Please contact us if you have any questions about the contents of the datasheet.

This may not be the latest version of the datasheet. Please check with us if a later version is available.

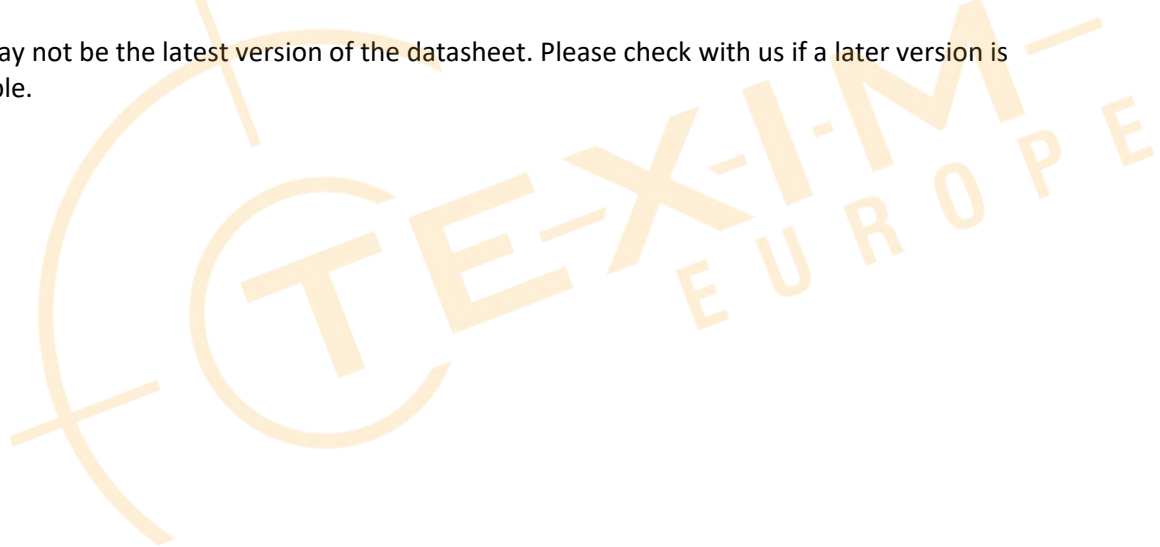



Headquarters & Warehouse

Elektrostraat 17
NL-7483 PG Haaksbergen
The Netherlands

T: +31 (0)53 573 33 33
E: info@texim-europe.com
Homepage: www.texim-europe.com



The Netherlands

Elektrostraat 17
NL-7483 PG Haaksbergen

T: +31 (0)53 573 33 33
E: nl@texim-europe.com



Belgium

Zuiderlaan 14, box 10
B-1731 Zellik

T: +32 (0)2 462 01 00
E: belgium@texim-europe.com



UK & Ireland

St Mary's House, Church Lane
Carlton Le Moorland
Lincoln LN5 9HS

T: +44 (0)1522 789 555
E: uk@texim-europe.com



Germany - North

Bahnhofstrasse 92
D-25451 Quickborn

T: +49 (0)4106 627 07-0
E: germany@texim-europe.com



Germany - South

Martin-Kollar-Strasse 9
D-81829 München

T: +49 (0)89 436 086-0
E: muenchen@texim-europe.com



Austria

Warwitzstrasse 9
A-5020 Salzburg

T: +43 (0)662 216 026
E: austria@texim-europe.com



Nordic

Søndre Jagtvej 12
DK-2970 Hørsholm

T: +45 88 20 26 30
E: nordic@texim-europe.com



Italy

Via Matteotti 43
IT-20864 Agrate Brianza (MB)

T: +39 (0)39 9713293
E: italy@texim-europe.com