

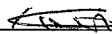

CLOVER DISPLAY LTD.

LCD MODULE SPECIFICATION

Model : CV9007D - _ _ - _ _ - _ _

Revision	05
Engineering	Timmy Kwan 
Date	17 May 2011
Our Reference	9024

ADDRESS : ROOM 1006, 10/F WESTIN CENTRE, 26 HUNG TO ROAD, KWUN TONG,
KOWLOON, HONG KONG.

TEL : (852) 2341 3238 (SALES OFFICE) (852) 2342 8228 (GENERAL OFFICE)

FAX : (852) 2357 4237 (SALES OFFICE) (852) 2341 8785 (GENERAL OFFICE)

E-MAIL : cdl@cloverdisplay.com

URL : <http://www.cloverdisplay.com>

MODE OF DISPLAY

Display mode

- STN : Yellow green
 Grey
 Blue (negative)
 FSTN positive
 FSTN negative

Display condition

- Reflective type
 Transflective type
 Transmissive type
 Others

Viewing direction

- 6 O' clock
 12 O' clock
 3 O' clock
 9 O' clock

LCD MODULE NUMBER NOTATION:

CV9007D - N N - S R - N 6 - T

(1)	(2)	(3)	(4)	(5)	(6)	(7)	(8)

* (1)---Model number of standard LCD Modules

* (2)---Backlight type

- N – No backlight
 E – EL backlight
 L – Side-lited LED backlight
 M – Array LED backlight
 C – CCFL

* (3)---Backlight color

- N – No backlight
 A – Amber
 B – Blue
 O – Orange
 W – White
 Y – Yellow green

* (4)---Display mode

- T – TN
 V – TN (Negative)
 S – STN Yellow green
 G – STN Grey
 B – STN Blue (Negative)
 F – FSTN
 N – FSTN (Negative)

* (5)---Rear polarizer type

- R – Reflective
 F – Transflective
 T – Transmissive

* (6)---Temperature range

- N – Normal
 W – Extended

* (7)---Viewing direction

- 6 – 6 O'clock
 2 – 12 O'clock
 3 – 3 O'clock
 9 – 9 O'clock

* (8)---Special code for other requirements
 (Can be omitted if not used)

GENERAL DESCRIPTION

Display mode : 128 x 64 Dots, Graphic COG LCD module
 Interface : Serial
 Driving method : 1/65 duty, 1/9 bias
 Controller IC : Sitronix ST7565P or equivalent
 For the detailed information, please refer to the IC specifications.

MECHANICAL DIMENSIONS

Item	Dimension	Unit	Item	Dimension	Unit
Outline Dimension					
No Backlight (N)	56.0(L)x38.5(W)x2.9(MAX)(H)	mm	Viewing Area	52.0(L)x26.5(W)	mm
LED Side Backlight(L)			Dot Pitch	0.38(L)x0.38(W)	mm
Yellow Green/White/Blue	61.0(L)x38.5(W)x7.0(MAX)(H)	mm	Dot Size	0.34(L)x0.34(W)	mm
Amber/Orange/Red	56.0(L)x38.5(W)x7.0(MAX)(H)	mm			

CONNECTOR PIN ASSIGNMENT

Pin No.	Symbol	Function	Pin No.	Symbol	Function
1	NC	No Connection	16	VLCD	Operating Voltage for LCD
2			17	VSS	Ground
3			18	VDD	Supply Voltage for Logic
4			19	SI	Serial Data Input
5	V0	Supply Voltage for LCD	20	SCL	Serial Clock Input
6	V1		21	A0	Data Control Signal
7	V2		22	/RES	Reset
8	V3		23	/CS1	Chip Select Signal
9	V4		24		
10	CAP4P	DC/DC Voltage Converter	25	NC	No Connection
11	CAP2N		26		
12	CAP2P		27		
13	CAP1P		*28	A	Supply Voltage for Backlight (+VE)
14	CAP1N		*29	K	Supply Voltage for Backlight (-VE)
15	CAP3P		—	—	—

Note: (*) Pin 28,29 are used for backlight version.

COUNTER DRAWING OF MODULE DIMENSION

MARK	REASON	PREPARED	DATE
△	Change backlight design & spec.	Joe Mok	18 APR 05
△	Add red color backlight spec.	Timmy	30 AUG 07
△	Add amber & orange color backlight spec.	Timmy	06 MAY 08
△	Update backlight spec.	Timmy	13 MAY 11

White / Blue / Yellow green color side-lit backlight

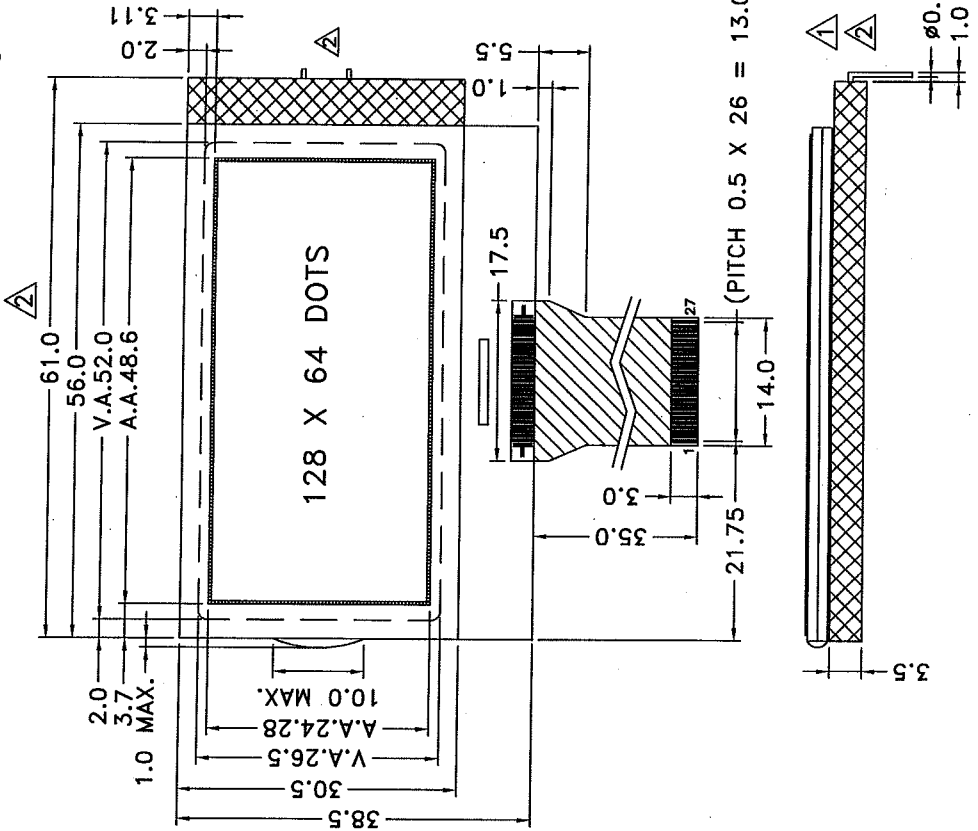

REV.	REVISION RECORD	UNIT IN mm	DATE
00	1st ISSUE	N.T.S.	13 MAY 04
01	Add backlight spec.		10 NOV 04
02	Change backlight design & spec.		18 APR 05
03	Add red color backlight spec.		30 AUG 07
04	Add amber & orange color backlight spec.		06 MAY 08
05	Update backlight spec.		13 MAY 11

TOLERANCE IF NOT SPECIFY SCALE	±0.5mm
REVISION RECORD	N.T.S.
1st ISSUE	
Add backlight spec.	
Change backlight design & spec.	
Add red color backlight spec.	
Add amber & orange color backlight spec.	
Update backlight spec.	

MARK	REASON	PREPARED	DATE
△	Change backlight design & spec.	Joe Mok	18 APR 05
△	Add red color backlight spec.	Timmy	30 AUG 07
△	Add amber & orange color backlight spec.	Timmy	06 MAY 08
△	Update backlight spec.	Timmy	13 MAY 11

MODEL NO.	TITLE:	DRAWN BY:	DATE:
CV9007D	MODULE DIMENSION 1	LYF	13 MAY 11
		CHECKED BY:	DATE: 16 May 11
		APPROVED BY:	DATE: 17 May 11

CUSTOMER	AGENT	OUR REF.	X9024
CLOVER DISPLAY LTD. (HK)	STANDARD		

COUNTER DRAWING OF MODULE DIMENSION

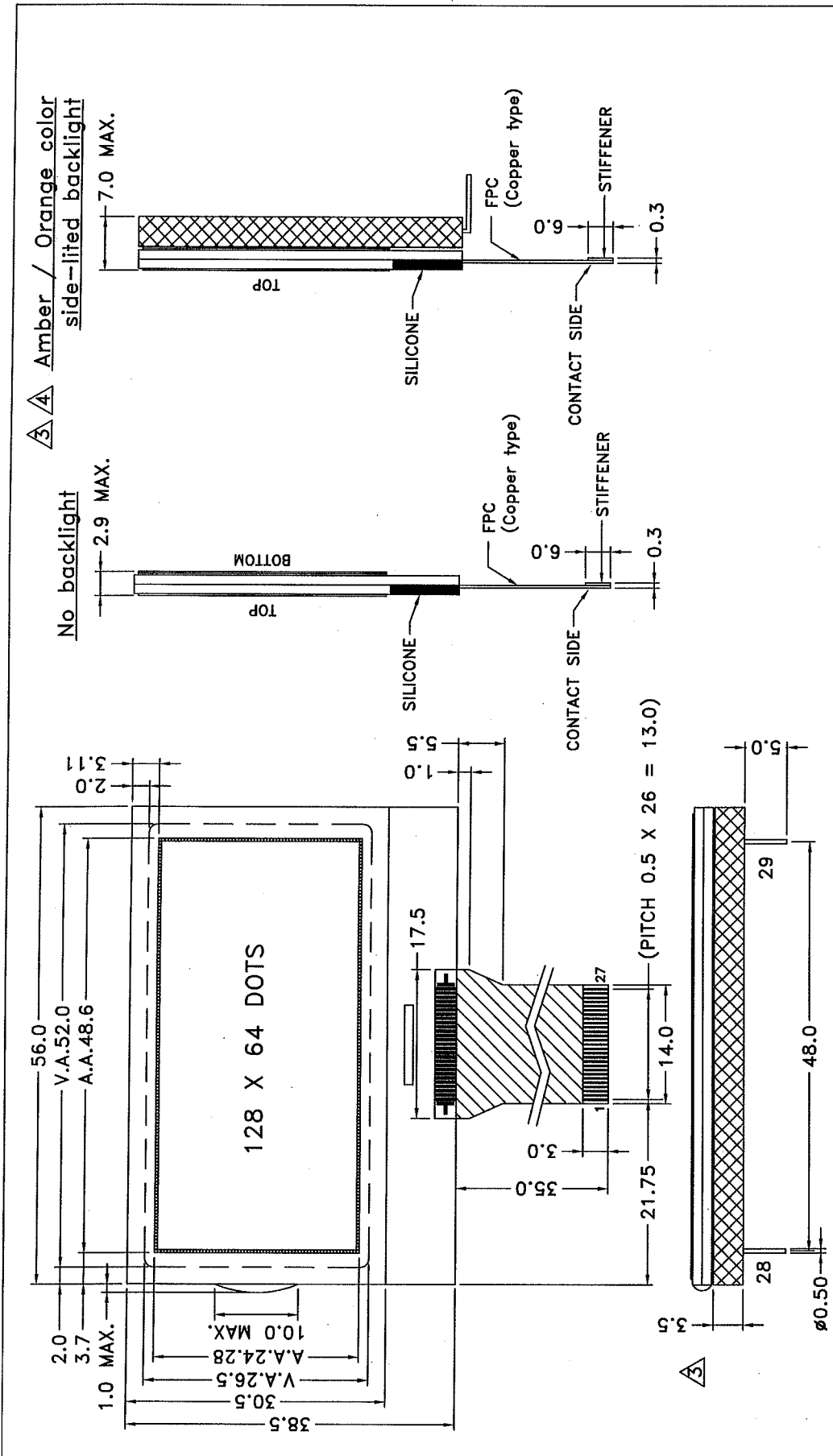

③ Amber / Orange color side-lit backlight

No backlight 2.9 MAX.

TOLERANCE IF NOT SPECIFY SCALE ±0.5mm		SCALE N.T.S.	UNIT IN mm	CLOVER DISPLAY LTD. (HK)		SHEET 2 OF 4
REV.	REVISION RECORD	DATE	UNIT	CUSTOMER	APPROVED	MODEL NO. CV9007D
00	1st ISSUE	13 MAY 04				TITLE: MODULE DIMENSION 2
01	Add backlight spec.	10 NOV 04				DRAWN BY: LYF DATE: 13 MAY 11
02	Change backlight design & spec.	18 APR 05		AGENT	APPROVED	CHECKED BY: <i>[Signature]</i> DATE: 16 May 11
03	Add red color backlight spec.	30 AUG 07				APPROVED BY: <i>[Signature]</i> DATE: 11/11
04	Add amber & orange color backlight spec.	06 MAY 08				
05	Update backlight spec.	13 MAY 11		CUSTOMER REF.	OUR REF. X9024	

COUNTER DRAWING OF PIN OUT & BLOCK DIAGRAM

PIN NUMBER	SYMBOL	FUNCTION
1	NC	
2	NC	
3	NC	NO connection
4	NC	
5	V0	
6	V1	
7	V2	Supply voltage for LCD
8	V3	
9	V4	
10	CAP4P	
11	CAP2N	
12	CAP2P	
13	CAP1P	
14	CAP1N	
15	CAP3P	DC/DC voltage converter
16	VLCD	
17	VSS	Operating voltage for LCD
18	VDD	Ground(0V)
19	SI	Supply voltage for logic
20	SCL	Serial data input
21	A0	Serial clock input
22	/RES	Data control signal
23	/CS1	Reset
24	NC	Chip select signal
25	NC	
26	NC	
27	NC	NO connection
△ *28	A	Supply voltage for backlight (+VE)
△ *29	K	Supply voltage for backlight (-VE)

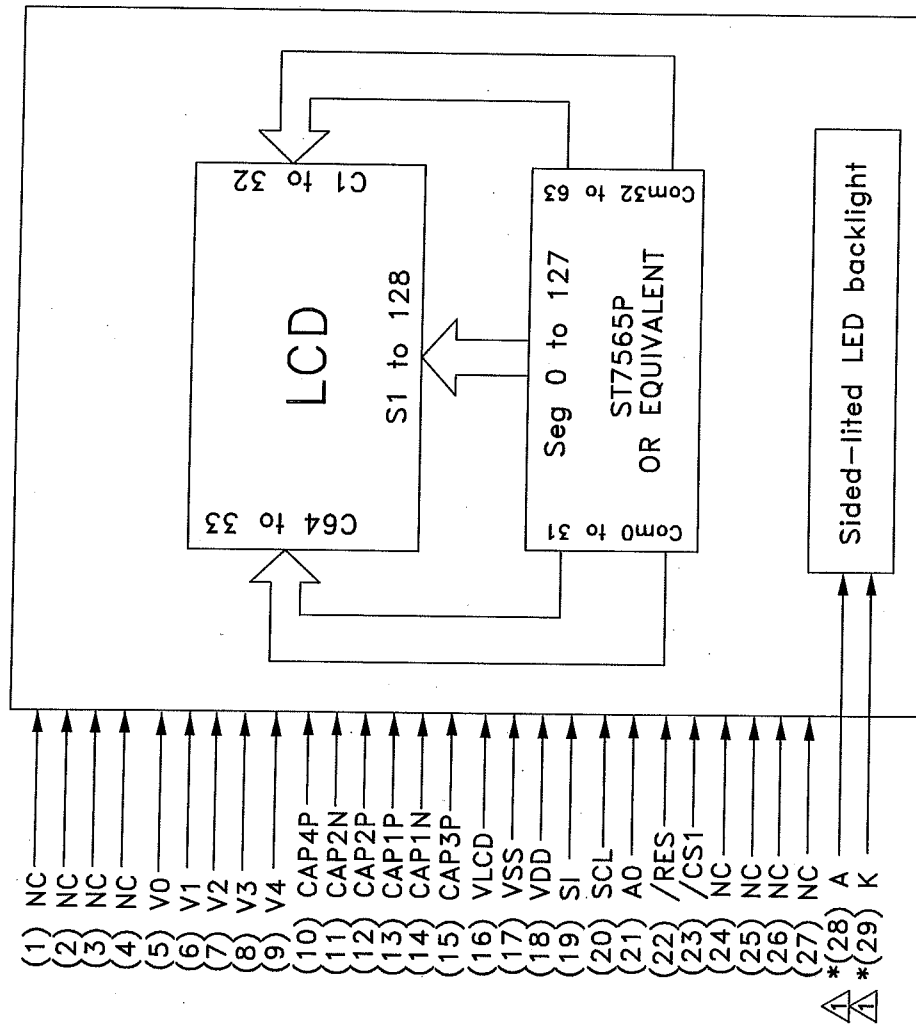

△ Note (*): Pin28,29 are for backlight versions only.

TOLERANCE IF NOT SPECIFY SCALE ±0.5mm		SCALE N.T.S.		UNIT IN mm		CLOVER DISPLAY LTD. (HK)		SHEET 3 OF 4	
REV.	REVISION RECORD	DATE	DATE	CUSTOMER	APPROVED	MODEL NO.	CV9007D	TITLE: PIN & BLOCK DIAGRAM	
00	1st ISSUE	13 MAY 04	10 NOV 04	STANDARD				DRAWN BY: LYF	DATE: 13 MAY 11
01	Add backlight spec.			AGENT	APPROVED			CHECKED BY: <i>[Signature]</i>	DATE: 16 May 11
02	Change backlight design & spec.							APPROVED BY: <i>[Signature]</i>	DATE: 17 May 11
03	Add red color backlight spec.								
04	Add amber & orange color backlight spec.								
05	Update backlight spec.							OUR REF. X9024	

ELECTRICAL CHARACTERISTICS

Conditions: VSS=0V, Ta=25°C

Item	Symbol	MIN.	TYP.	MAX.	Unit
Supply Voltage for Logic	VDD	2.75	3.0	3.25	V
Supply Current for Logic	IDD	—	0.2	0.45	mA
Operating Voltage for LCD (*)	VLCD	11.4	12.0	12.6	V
'High' Level Input Voltage	VIH	0.8VDD	—	VDD	V
'Low' Level Input Voltage	VIL	VSS	—	0.2VDD	V

Note (*): There is tolerance in optimum LCD driving voltage during production and it will be within the specified range.

Side-lite backlight:

Constant voltage driving:

Item	Symbol	MIN.	TYP.	MAX.	Unit	Condition
White BL current	I _{BL}	17	20	23	mA	V _{BL} = 3.5V
Blue BL current	I _{BL}	34	36	40	mA	V _{BL} = 3.5V
Yellow Green BL current	I _{BL}	34	36	40	mA	V _{BL} = 3.5V
Red BL current	I _{BL}	45	53	60	mA	V _{BL} = 3.5V
Amber BL current	I _{BL}	45	53	60	mA	V _{BL} = 3.5V
Orange BL current	I _{BL}	45	53	60	mA	V _{BL} = 3.5V

ABSOLUTE MAXIMUM RATINGS

Please make sure not to exceed the following maximum rating values under the worst application conditions

Item	Symbol	Rating (for normal temperature)	Rating (for wide temperature)	Unit
Supply Voltage	VDD	-0.3 to 3.6	-0.3 to 3.6	V
Operating Temperature	Topr	0 to 50	-20 to 70	°C
Storage Temperature	Tstg	-10 to 60	-30 to 80	°C

REFERENCE CIRCUIT EXAMPLE

5X boosting circuit.

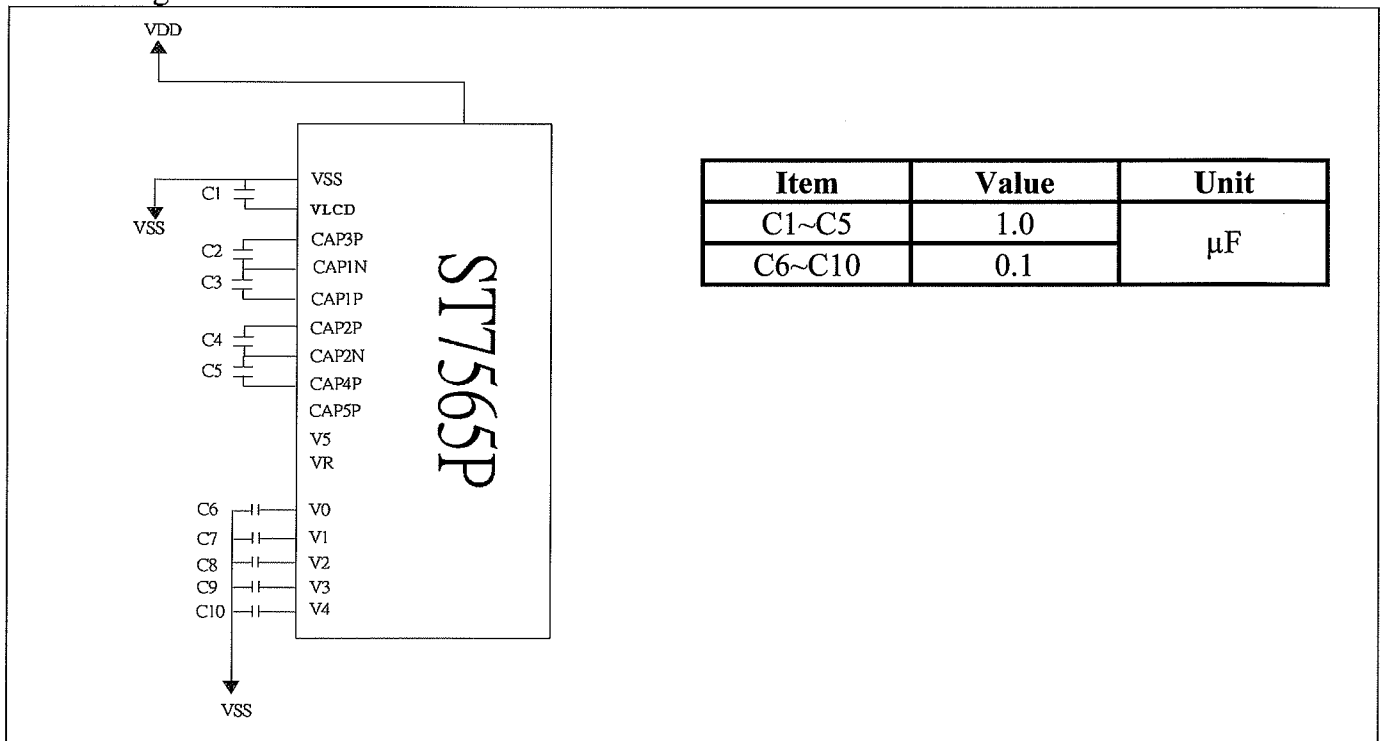

Item	Value	Unit
C1~C5	1.0	μF
C6~C10	0.1	

INSTRUCTIONS

(Note) *: disabled data

Command	Command Code										Function	
	A0	/RD	/WR	D7	D6	D5	D4	D3	D2	D1		D0
(1) Display ON/OFF	0	1	0	1	0	1	0	1	1	1	0	LCD display ON/OFF 0: OFF, 1: ON
(2) Display start line set	0	1	0	0	1	Display start address					1	Sets the display RAM display start line address
(3) Page address set	0	1	0	1	0	1	1	Page address				Sets the display RAM page address
(4) Column address set upper bit	0	1	0	0	0	0	1	Most significant column address				Sets the most significant 4 bits of the display RAM column address. Sets the least significant 4 bits of the display RAM column address.
Column address set lower bit	0	1	0	0	0	0	0	Least significant column address				
(5) Status read	0	0	1	Status				0	0	0	0	Reads the status data
(6) Display data write	1	1	0	Write data								Writes to the display RAM
(7) Display data read	1	0	1	Read data								Reads from the display RAM
(8) ADC select	0	1	0	1	0	1	0	0	0	0	0	Sets the display RAM address SEG output correspondence 0: normal, 1: reverse
(9) Display normal/reverse	0	1	0	1	0	1	0	0	1	1	0	Sets the LCD display normal/reverse 0: normal, 1: reverse
(10) Display all points ON/OFF	0	1	0	1	0	1	0	0	1	0	0	Display all points 0: normal display 1: all points ON
(11) LCD bias set	0	1	0	1	0	1	0	0	0	1	0	Sets the LCD drive voltage bias ratio 0: 1/9 bias, 1: 1/7 bias (ST7565P)
(12) Read/modify/write	0	1	0	1	1	1	0	0	0	0	0	Column address increment At write: +1 At read: 0
(13) End	0	1	0	1	1	1	0	1	1	1	0	Clear read/modify/write
(14) Reset	0	1	0	1	1	1	0	0	0	1	0	Internal reset
(15) Common output mode select	0	1	0	1	1	0	0	0	*	*	*	Select COM output scan direction 0: normal direction 1: reverse direction
(16) Power control set	0	1	0	0	0	1	0	1	Operating mode			Select internal power supply operating mode
(17) Vo voltage regulator internal resistor ratio set	0	1	0	0	0	1	0	0	Resistor ratio			Select internal resistor ratio(Rb/Ra) mode
(18) Electronic volume mode set	0	1	0	1	0	0	0	0	0	0	1	Set the Vo output voltage electronic volume register
Electronic volume register set				0	0	Electronic volume value						
(19) Static indicator ON/OFF	0	1	0	1	0	1	0	1	1	0	0	0: OFF, 1: ON
Static indicator register set				0	0	0	0	0	0	0	0	0
(20) Booster ratio set	0	1	0	1	1	1	1	1	0	0	0	select booster ratio 00: 2x,3x,4x 01: 5x 11: 6x
(21) Power saver												Display OFF and display all points ON compound command
(22) NOP	0	1	0	1	1	1	0	0	0	1	1	Command for non-operation
(23) Test	0	1	0	1	1	1	1	*	*	*	*	Command for IC test. Do not use this command

RECOMMENDED SETTINGS

- Display Start Line Set : 40H
- ADC Select : A0H
- LCD Bias Set : A2H
- Common Output Mode Select : C8H
- Power Control Set: 2FH
- V0 Voltage Regulator Internal Resistor Ratio Set : 27H
- Electronic Volume Register Set : 2FH
- Booster Ratio Set : 01H

DISPLAY DATA RAM (DDRAM)

The display data RAM stores the dot data for the LCD. It has a 65 (8 page x 8 bit +1) x 132 bit structure.

As is shown in Figure 3, the D7 to D0 display data from the MPU corresponds to the LCD display common direction; there are few constraints at the time of display data transfer when multiple ST7565P are used, thus and display structures can be created easily and with a high degree of

freedom.

Moreover, reading from and writing to the display RAM from the MPU side is performed through the I/O buffer, which is an independent operation from signal reading for the liquid crystal driver. Consequently, even if the display data RAM is accessed asynchronously during liquid crystal display, it will not cause adverse effects on the display (such as flickering).

D0	0	1	1	1		0
D1	1	0	0	0		0
D2	0	0	0	0		0
D3	0	1	1	1		0
D4	1	0	0	0		0

Display data RAM

COM0		■	■	■		
COM1	■					
COM2						
COM3		■	■	■		
COM4	■					

Liquid crystal display

COLUMN ADDRESS

The display data RAM column address is specified by the Column Address Set command. The specified column address is incremented (+1) with each display data read/write command. This allows the MPU display data to be accessed continuously. Moreover, the incrementing of column addresses stops with 83H. Because the column address is independent of the page address, when moving, for example, from page 0 column 83H to page 1 column 00H,

it is necessary to respect both the page address and the column address.

Furthermore, as is shown in Table 4, the ADC command (segment driver direction select command) can be used to reverse the relationship between the display data RAM column address and the segment output. Because of this, the constraints on the IC layout when the LCD module is assembled can be minimized. As is shown in Figure 4,

Table 4

SEG Output ADC	SEG0	SEG 131
(D0) "0"	0 (H) → Column Address →	83 (H)
(D0) "1"	83 (H) ← Column Address ←	0 (H)

LINE ADDRESS CIRCUIT

The line address circuit, as shown in Table 4, specifies the line address relating to the COM output when the contents of the display data RAM are displayed. Using the display start line address set command, what is normally the top line of the display can be specified (this is the COM0 output when the common output mode is normal, and the COM63 output for ST7565P). The display area is a 65 line area for the ST7565P.

If the line addresses are changed dynamically using the display start line address set command, screen scrolling, page swapping, etc. can be performed.

PAGE ADDRESS CIRCUIT

Page address of the display data RAM is specified through the Page Address Set Command. The page address must be specified again when changing pages to perform access.

Page address 8 (D3, D2, D1, D0 = 1, 0, 0, 0) is a special RAM for icons, and only display data D0 is used.

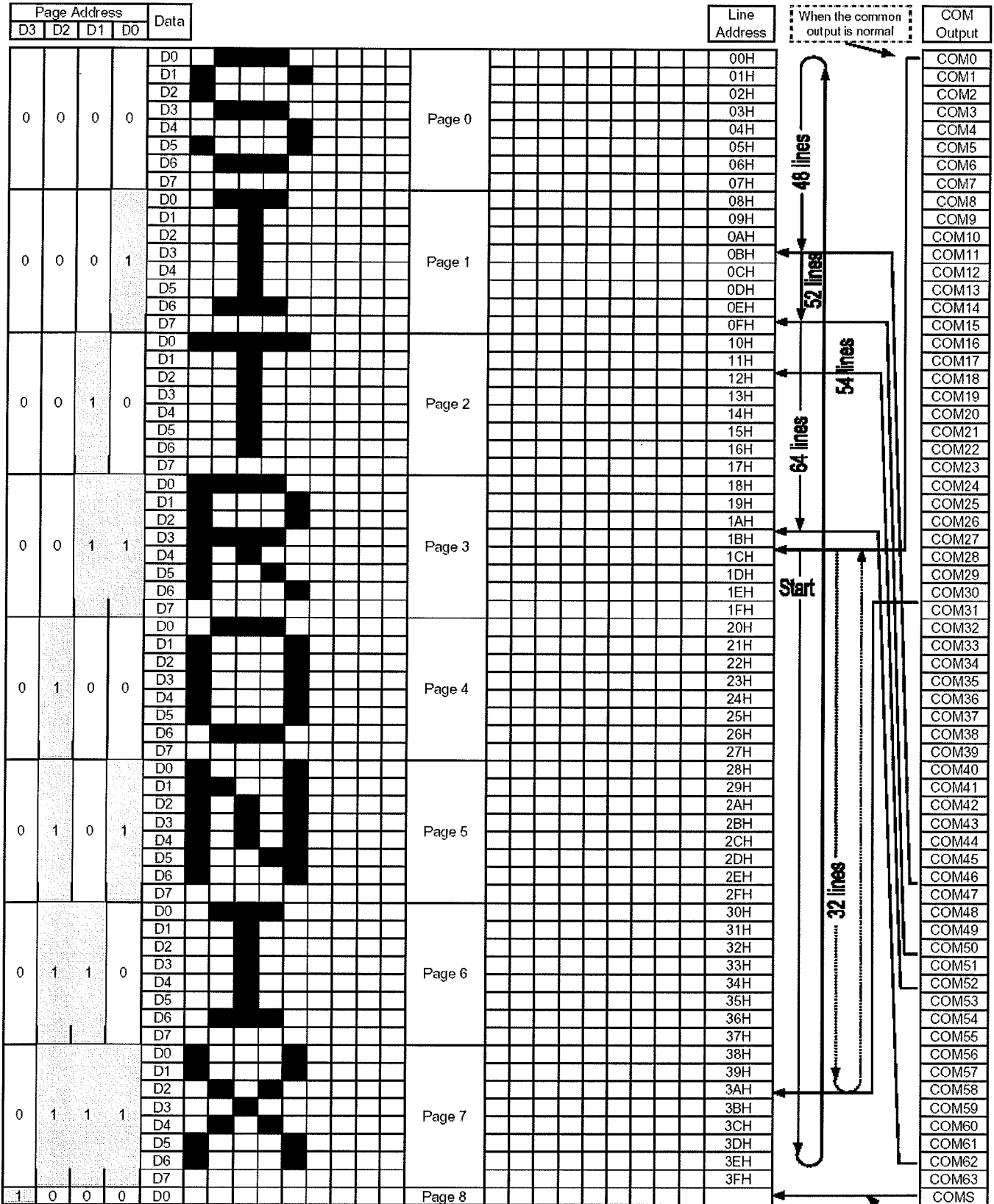

Regardless of the display start line address,
 1/65duty => 64th line.
 1/49duty => 48th line.
 1/33duty => 32th line.
 1/55duty => 54th line.
 1/53duty => 52th line.

AC CHARACTERISTICS

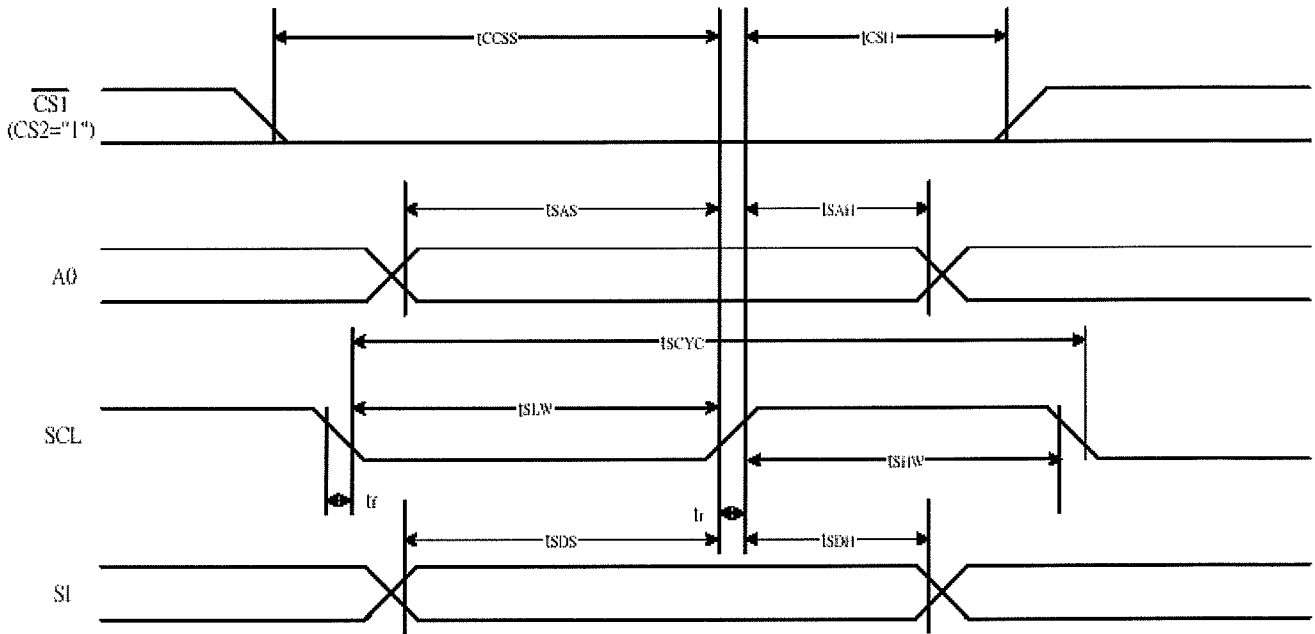

Item	Signal	Symbol	Condition	Rating		Units
				Min.	Max.	
Serial Clock Period	SCL	T _{scyc}		100	—	ns
SCL "H" pulse width		T _{shw}		50	—	
SCL "L" pulse width		T _{slw}		50	—	
Address setup time	A0	T _{sas}		20	—	
Address hold time		T _{сах}		10	—	
Data setup time	SI	T _{sds}		20	—	
Data hold time		T _{sdh}		10	—	
CS-SCL time	CS	T _{css}		20	—	
CS-SCL time		T _{csн}		40	—	

RESET TIMING

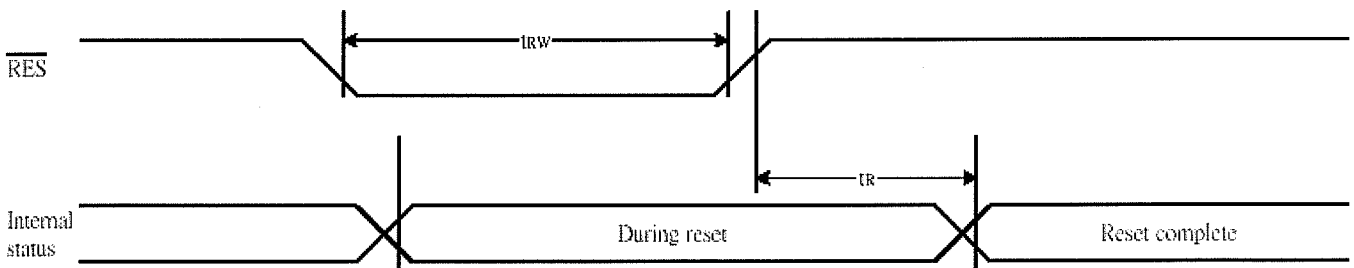

Item	Signal	Symbol	Condition	Rating			Units
				Min.	Typ.	Max.	
Reset time		tr		—	—	1.0	us
Reset "L" pulse width	/RES	trw		1.0	—	—	us

INITIALIZATION METHOD

1. When the built-in power is being used immediately after turning on the power:

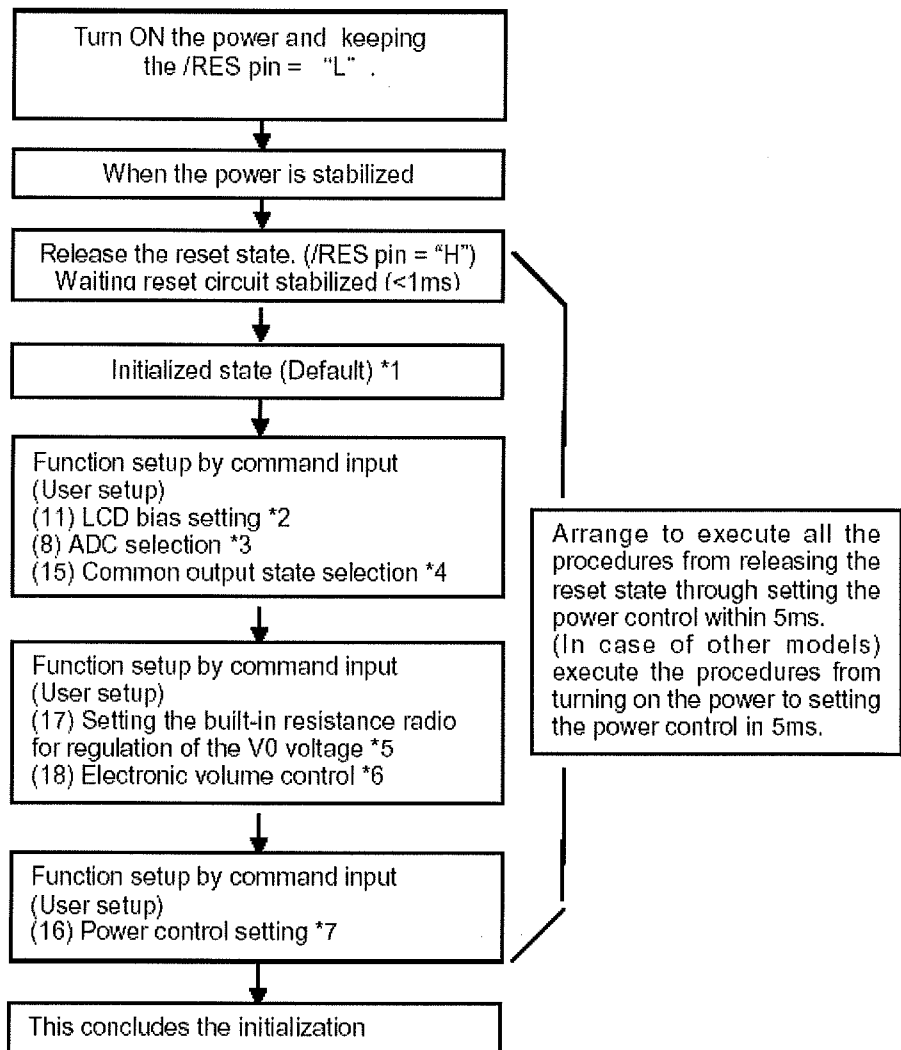

* The target time of 5ms will result to vary depending on the panel characteristics and the capacitance of the smoothing capacitor. Therefore, we suggest you to conduct an operation check using the actual equipment.

Notes: Refer to respective sections or paragraphs listed below.

*1: Description of functions; Resetting circuit

*2: Command description; LCD bias setting

*3: Command description; ADC selection

*4: Command description; Common output state selection

*5: Description of functions; Power circuit & Command description; Setting the built-in resistance ratio for regulation of the V0 voltage

*6: Description of functions; Power circuit & Command description; Electronic volume control

*7: Description of functions; Power circuit & Command description; Power control setting

ELECTRO-OPTICAL CHARACTERISTICS

MEASURING CONDITION: POWER SUPPLY = $V_{OP} / 64 \text{ Hz}$
 TEMPERATURE = $23 \pm 5 \text{ }^\circ\text{C}$
 RELATIVE HUMIDITY = $60 \pm 20 \%$

ITEM	SYMBOL	UNIT	TYP. STN
RESPONSE TIME	T_{on}	ms	220
	T_{off}	ms	280
CONTRAST RATIO	Cr	-	12
VIEWING ANGLE (6 O'clock) (Cr \geq 2)	V3:00	$^\circ$	40
	V6:00	$^\circ$	70
	V9:00	$^\circ$	40
	V12:00	$^\circ$	50

THE ELECTRO-OPTICAL CHARACTERISTICS ARE MEASURED VALUE BUT NOT GUARANTEED ONES.

RELIABILITY OF LCD MODULE

ITEM	TEST CONDITION FOR NORMAL TEMPERATURE	TEST CONDITION FOR WIDE TEMPERATURE	TIME
High temperature operating	50 $^\circ\text{C}$	70 $^\circ\text{C}$	240 hours
Low temperature operating	0 $^\circ\text{C}$	-20 $^\circ\text{C}$	240 hours
High temperature storage	60 $^\circ\text{C}$	80 $^\circ\text{C}$	240 hours
Low temperature storage	-10 $^\circ\text{C}$	-30 $^\circ\text{C}$	240 hours
Temperature-humidity storage	40 $^\circ\text{C}$ 90% R.H.	60 $^\circ\text{C}$ 90% R.H.	96 hours
Temperature cycling	-10 $^\circ\text{C}$ to 60 $^\circ\text{C}$ 30 Min Dwell	-30 $^\circ\text{C}$ to 80 $^\circ\text{C}$ 30 Min Dwell	5 cycle
Vibration Test at LCM Level	Freq 10-55 Hz Sweep rate: 10-55-10 at 1 min Sweep mode Linear Displacement: 2 mm p-p 1 Hour each for X, Y, Z	Freq 10-55 Hz Sweep rate: 10-55-10 at 1 min Sweep mode Linear Displacement: 2 mm p-p 1 Hour each for X, Y, Z	—

SAMPLING METHOD

SAMPLING PLAN: MIL-STD 105E

CLASS OF AQL: LEVEL II/ SINGLE SAMPLING
 MAJOR-0.65% MINOR - 1.5%

QUALITY STANDARD

DEFECT	CRITERIA	TYPE	FIGURE
SHORT CIRCUIT	-	MAJOR	-
MISSING SEGMENT	-	MAJOR	-
UNEVEN / POOR CONTRAST	-	MAJOR	-
CROSS TALK	-	MAJOR	-
PIN HOLE	$MAX(a,b) \leq 1/4 W$	MINOR	1
EXCESS SEGMENT	$MAX(c,d) \leq 1/4 T$	MINOR	1
BUBBLES	$d^* \geq 0.2$ QTY=0	MINOR	2
BLACKS SPOTS	$d \leq 0.3$ N.A.** $0.3 < d \leq 0.4$ QTY \leq 1 $0.4 < d$ QTY=0	MINOR	2
LINE SCRATCHES	$x \geq 0.7$ $y \geq 0.05$ QTY=0	MINOR	3
BLACK LINE	$x \geq 0.7$ $y \geq 0.05$ QTY=0	MINOR	3

*d = MAX (d₁,d₂)

** N. A . = NOT APPLICABLE

DEFECT TABLE : B

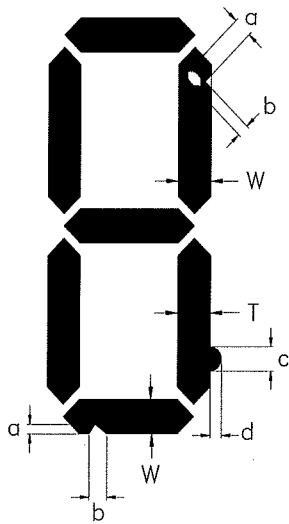
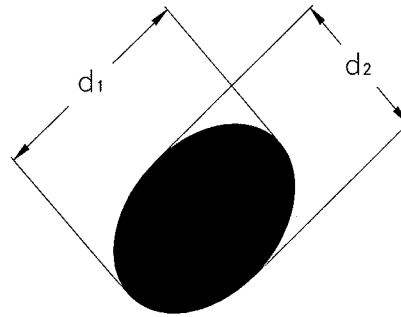
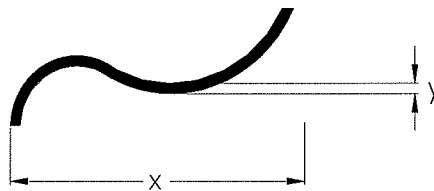

fig . 1



POLARIZER BUBBLES / SPOTS
fig . 2



LINE SCRATCHES / BLACK LINE
fig . 3

QUALITY STANDARD (CONT .)

DEFECT	CRITERIA		TYPE	FIGURE
CHIPS	CONTACT EDGE	$e \leq 1/2T$ $f \leq 1/3W$ $g \leq 3.5$	MINOR	4
	BOTTOM GLASS	$p \leq 1.0$ $q \leq 3.5$ $r \leq 1/2T$		4
	CORNER	$a \leq 1.5$ $b \leq W$		4
	TOP GLASS	$a \leq 3.0$ $b \leq 1/3T$ $c \leq 1/2W$		5
GLASS PROTRUSION	$a \leq 1/4 W$		MINOR	6
RAINBOW	-		MINOR	-

UNLESS STATE OTHERWISE , ALL UNIT ARE IN MILLIMETER .

DEFECT TABLE : B

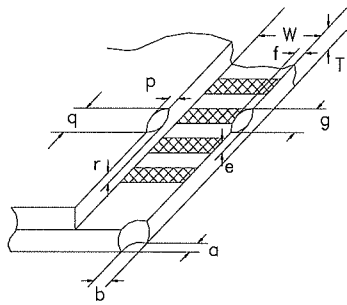

fig . 4

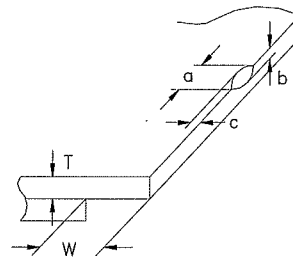

fig . 5

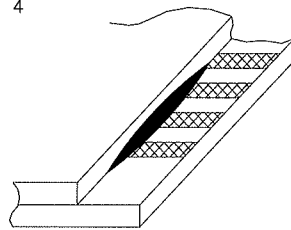
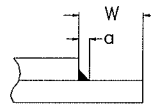

fig . 6



HANDLING PRECAUTIONS**(1) CAUTION OF LCD HANDLING & CLEANING**

Use soft cloth with solvent (recommended below) to clean the display surface and wipe lightly.
- Isopropyl alcohol, ethyl alcohol, trichlorotrifluoroethane

Do not wipe the display surface with dry or hard materials that will damage the polarizer surface. Do not use the following solvent;
-water, ketone, aromatics

(2) CAUTION AGAINST STATIC CHARGE

The LCD modules use CMOS LSI drivers, so customers are recommended that any unused input terminal would be connected to V_{DD} or V_{SS} , do not input any signals before power is turned on, and ground your body, work/assembly areas, assembly equipment to protect against static electricity.

Remove the protective film slowly and, if possible, under ESD control device like ion blower and humidity of working room should be kept over 50%RH to reduce risk of static charge.

(3) PACKAGING

Avoid intense shock and falls from a height and do not operate or store them exposed direct to sunshine or high temperature/humidity.

(4) CAUTION FOR OPERATION

It is an indispensable condition to drive LCD's within the specified voltage limit since the higher voltage than the limit causes the shorter LCD life. The use of direct current drive should be avoided because an electrochemical reaction due to direct current causes LCD's undesirable deterioration.

Response time will be extremely delayed at low temperature, and LCD's show dark color at high temperature. However those phenomena do not mean malfunction or out of order with LCD's.

Some font will be abnormally displayed when the display area is pushed hard during operation. But it resumes normal condition after turning off once.

(5) SOLDERING (for Pin type)

It is recommended to complete dip soldering at 270 °C or hand soldering at 280 °C within 3 seconds. The soldering position is at least 3mm apart from the pin head. Wave or reflow soldering are not recommended. Metal pins should not be soldered for more than 3 times and each soldering should be done after cool down of metal pins

(6) SAFETY

For crash damaged or unnecessary LCD's, it is recommended to wash off liquid crystal by either of solvents such as acetone and ethanol and should be burned up later.

When any liquid leaked out of a damaged glass cell comes in contact with your hands, wash it off with soap and water.

WARRANTY

CLOVER will replace or repair any of her LCD module in accordance with her LCD specification for a period of one year from date of shipment. The warranty liability of Clover is limited to repair and/or replacement. Clover will not be responsible for any subsequent or consequential event.