

Touch Side View

CONNECTOR PINOUT	
PIN#	DESIGNATION
1	Shielding
2	Blank
3-19	X1-X17
20-29	Y1-Y10
30	Blank

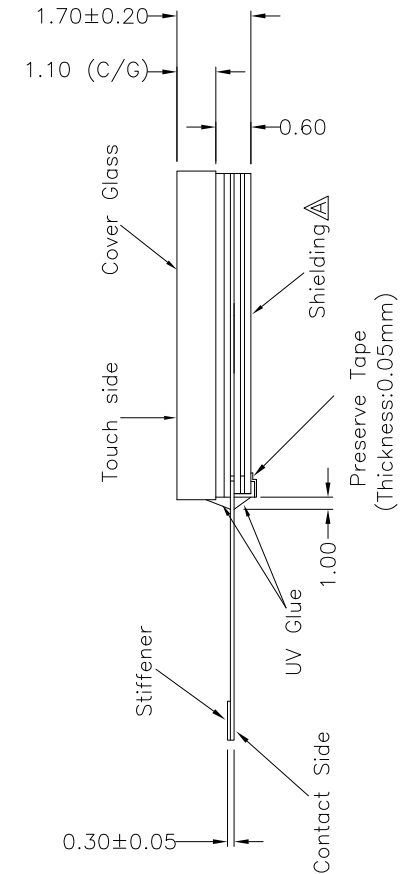
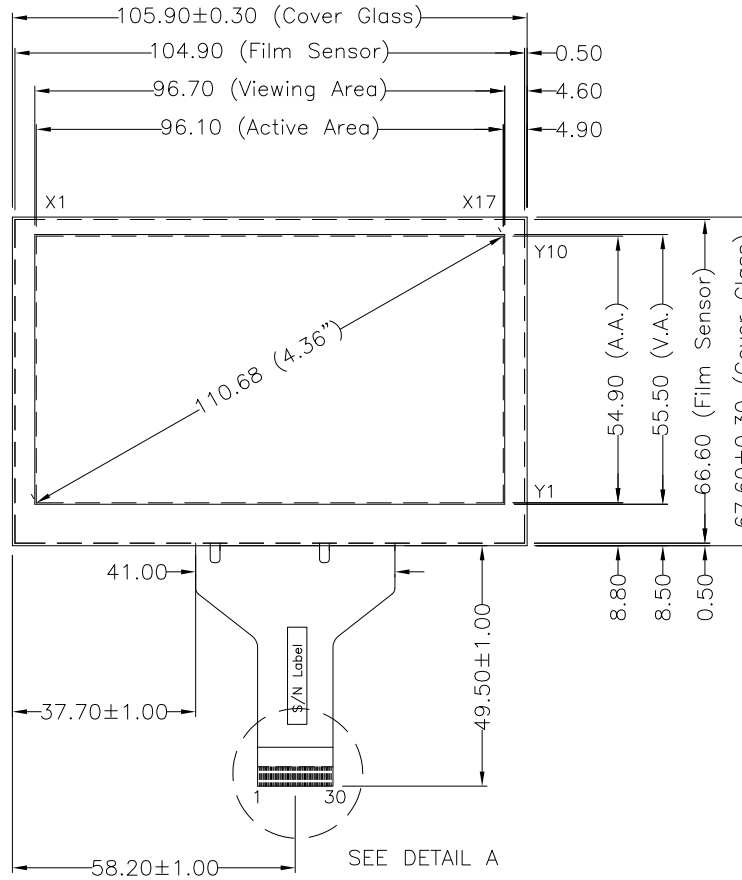
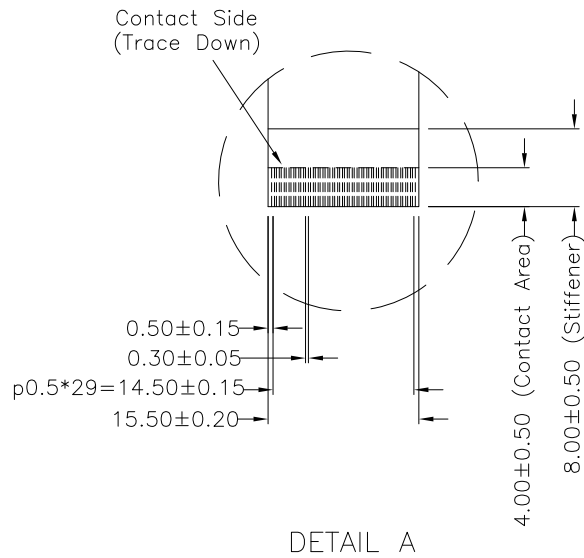

NOTES:

1. INPUT MODE : PROJECTED CAPACITIVE
2. OVERALL THICKNESS : 1.70±0.20mm
3. COVER GLASS THICKNESS : 1.10mm
4. FRONT SURFACE : CLEAR TYPE
5. TAIL TYPE : GOLD PLATED FPC , ZIF
6. RECOMMENDED CONTROL BOARDS : PENMOUNT PM1100 SERIES
7. OTHER SPEC : SEE APPROVAL SHEET



NO.	DATE	DESCRIPTION	CHK
REVISION			
CHIEF OF DESIGN		APPROVED	Jerry
ENGINEER		PROJECT MANAGER	
DRAWN BY	Andre	DATE	FEB 23, 2012
SHT	1	OF	1
REV.			A

Apex Material Technology Corp.	
TOLERANCES UNLESS SPECIFIED	MODEL NAME : P3003-02
.X	± 0.50
.XX	± 0.50
.XXX	± 0.30
ANGULAR	
DWG NO : P3003-02-1-01	
SCALE: N/S UNIT: mm	