



# Winstar Display Co., LTD

## 華凌光電股份有限公司



住址: 407 台中市中清路 163 號  
No.163 Chung Ching RD.,  
Taichune, Taiwan, R.O.C

WEB: <http://www.winstar.com.tw>  
E-mail: [winstar@winstar.com.tw](mailto:winstar@winstar.com.tw)  
Tel:886-4-24262208 Fax : 886-4-24262207



### SPECIFICATION

**CUSTOMER :** \_\_\_\_\_

**MODULE NO.:**           WO1602F-TFH-AT#          

<p align="center"><b>APPROVED BY:</b></p> <p align="center">( FOR CUSTOMER USE ONLY )</p>	<p align="center"><b>PCB VERSION: DATA:</b></p>
---	---

SALES BY	APPROVED BY	CHECKED BY	PREPARED BY

VERSION	DATE	REVISED PAGE NO.	SUMMARY
B	2008.10.29	16	Modify Backlight information

MODLE NO :

RECORDS OF REVISION			DOC. FIRST ISSUE
VERSION	DATE	REVISED PAGE NO.	SUMMARY
0	2008/5/14		First issue
A	2008.09.11	14	Correct drawing.
B	2008.10.29	16	Modify Backlight information

# Contents

1. Module Classification Information
2. Precautions in use of LCD Modules
3. General Specification
4. Absolute Maximum Ratings
5. Electrical Characteristics
6. Optical Characteristics
7. Interface Pin Function
8. Contour Drawing
9. Function Description
10. Application SCH
11. Reliability
12. Backlight Information
13. Inspection specification
14. Material List of Components for RoHs



## 2. Precautions in use of LCD Modules

- (1) Avoid applying excessive shocks to the module or making any alterations or modifications to it.
- (2) Don't make extra holes on the printed circuit board, modify its shape or change the components of LCD module.
- (3) Don't disassemble the LCM.
- (4) Don't operate it above the absolute maximum rating.
- (5) Don't drop, bend or twist LCM.
- (6) Soldering: only to the I/O terminals.
- (7) Storage: please storage in anti-static electricity container and clean environment.
- (8) Winstar have the right to change the passive components
- (9) Winstar have the right to change the PCB Rev.

## 3. General Specification

<b>Item</b>	<b>Dimension</b>	<b>Unit</b>
Number of Characters	16 characters x 2 Lines	—
Module dimension	72.1x 29.6 x9.4	mm
View area	61.0 x 15.1	mm
Active area	56.2 x 11.5	mm
Dot size	0.55 x 0.65	mm
Dot pitch	0.60 x 0.70	mm
Character size	2.96 x 5.55	mm
Character pitch	3.55 x 5.95	mm
LCD type	FSTN Positive, Transflective (In LCD production, It will occur slightly color difference. We can only guarantee the same color in the same batch.)	
Duty	1/16 , 1/5 Bias	
View direction	6 o'clock	
Backlight Type	LED White	

## 4. Absolute Maximum Ratings

Item	Symbol	Min	Typ	Max	Unit
Operating Temperature	$T_{OP}$	-20	—	+70	°C
Storage Temperature	$T_{ST}$	-30	—	+80	°C
Supply voltage for Logic	$V_{DD}$	-0.3	—	6.0	V
LCD Driver Voltage	$V_{LCD}$	7.0- $V_{SS}$		-0.3+ $V_{SS}$	V

## 5. Electrical Characteristics

Item	Symbol	Condition	Min	Typ	Max	Unit
Supply Voltage For Logic	$V_{DD}-V_{SS}$	—	3	3.3	5 (bon=1 max=3.5V)	V
Supply Voltage For LCM	$V_{out}-V_{SS}$	$T_a=-20^{\circ}C$	—	—	—	V
		$T_a=25^{\circ}C$	4.1	4.5	4.8	V
		$T_a=70^{\circ}C$	—	—	—	V
Input High Volt.	$V_{IH}$	—	0.7 $V_{DD}$	—	$V_{DD}$	V
Input Low Volt.	$V_{IL}$	—	—	—	0.2 $V_{DD}$	V
Output High Volt.	$V_{OH}$	—	0.8 $V_{DD}$	—	$V_{DD}$	V
Output Low Volt.	$V_{OL}$	—	—	—	0.2 $V_{DD}$	V
Supply Current(No include LED Backlight)	$I_{DD}$	$V_{DD}=3.3V$	0.15	0.2	0.4	mA

# 6. Optical Characteristics

Item	Symbol	Condition	Min	Typ	Max	Unit
View Angle	(V) $\theta$	$CR \geq 2$	30	—	60	deg
	(H) $\varphi$	$CR \geq 2$	-45	—	45	deg
Contrast Ratio	CR	—	—	5	—	—
Response Time	T rise	—	—	250	400	ms
	T fall	—	—	100	250	ms

## Definition of Operation Voltage (Vop)

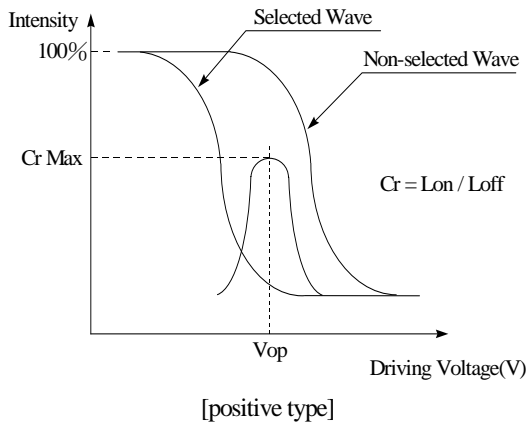

## Definition of Response Time (Tr, Tf)

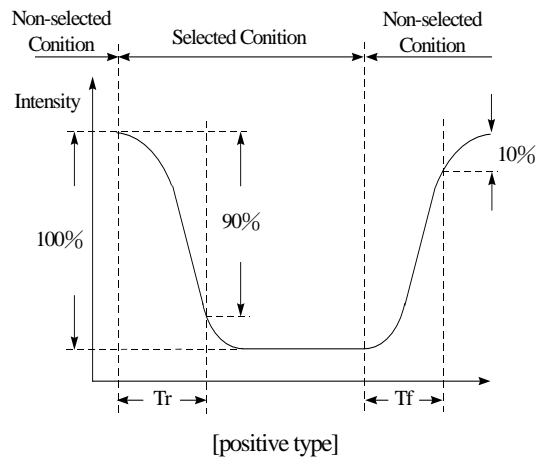

### Conditions :

Operating Voltage : Vop      Viewing Angle( $\theta$  ,  $\varphi$ ) :  $0^\circ$  ,  $0^\circ$   
 Frame Frequency : 64 HZ      Driving Waveform : 1/N duty , 1/a bias

## Definition of viewing angle( $CR \geq 2$ )

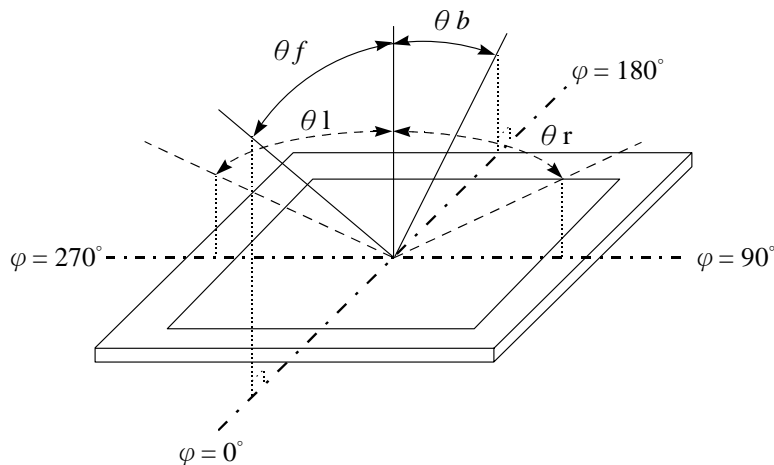

## 7. Interface Pin Function

Pin No.	Symbol	Level	Description															
1	RS	H/L	Select registers. 0: Instruction register (for write) Busy flag & address counter (for read) 1: Data register (for write and read)															
2	R/W	H/L	Select read or write (In parallel mode). 0: Write 1: Read															
3	E	H,H→L	Starts data read/write. (“E” must connect to “VDD” when serial interface is selected.)															
4	DB0	H/L	Data bus line															
5	DB1	H/L	Data bus line															
6	DB2	H/L	Data bus line															
7	DB3	H/L	Data bus line															
8	DB4	H/L	Data bus line															
9	DB5	H/L	Data bus line															
10	DB6/SCL	H/L	Data bus line (In I2C interface DB6 (SCL) is clock input. SDA and SCL must connect to I2C bus (I2C bus is to connect a resistor between SDA/SCL and the power of I2C bus ).															
11	DB7/SDA	H/L	Data bus line (In I2C interface DB7 (SDA) is input data. SDA and SCL must connect to I2C bus (I2C bus is to connect a resistor between SDA/SCL and the power of I2C bus ).															
12	V <sub>SS</sub>	0V	Ground															
13	V <sub>DD</sub>	3.3/5.0V (bon=1 Max=3.5 V	Supply Voltage for logic															
14	Vout	(Variable)	Operating voltage for LCD															
15	PSB		Interface selection 0:serial mode (“E” must connect to “VDD” when serial mode is selected.) 1:parallel mode(4/8 bit) In I2C interface PSB must connect to VDD															
16	PSI2B		<table border="1"> <thead> <tr> <th>PSB</th> <th>PSI2B</th> <th>Interface</th> </tr> </thead> <tbody> <tr> <td>0</td> <td>0</td> <td>No use</td> </tr> <tr> <td>0</td> <td>1</td> <td>SI4</td> </tr> <tr> <td>1</td> <td>0</td> <td>SI2 (I<sup>2</sup>C )</td> </tr> <tr> <td>1</td> <td>1</td> <td>Parallel 68</td> </tr> </tbody> </table>	PSB	PSI2B	Interface	0	0	No use	0	1	SI4	1	0	SI2 (I <sup>2</sup> C )	1	1	Parallel 68
PSB	PSI2B	Interface																
0	0	No use																
0	1	SI4																
1	0	SI2 (I <sup>2</sup> C )																
1	1	Parallel 68																
17	CAP1P		For voltage booster circuit(VDD-VSS)															



18	CAP1N		External capacitor about 0.1u~4.7uf
19	NC		No connection
20	NC		No connection

# 8. Contour Drawing

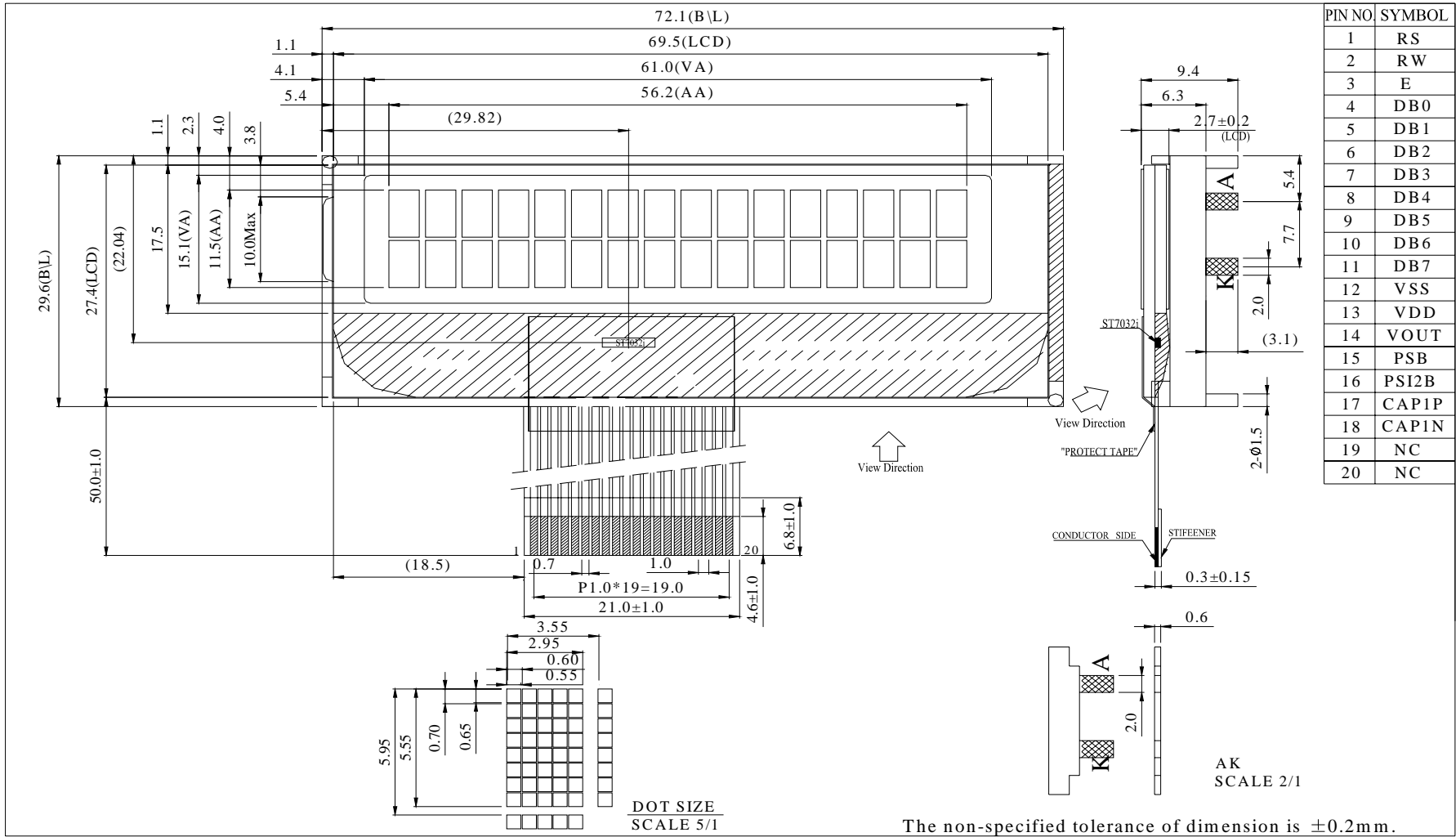

## 9.Function Description

**Please consult the spec of ST7032i**

# 10. Application SCH

WO1602F APPLICATION FOR 3V / Serial INTERFACE

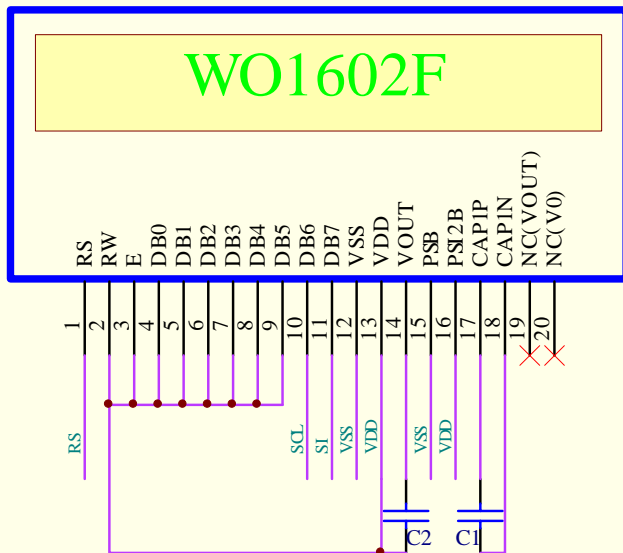

- ST7032i over Glass  
 Bon : set booster circuit on / FON = 1  
 Pin connection :
- 01.EXT=0
  - 02.OPR1=0
  - 03.OPR2=0
  - 04.SHLC=0
  - 05.SHLS=0
  - 06.OPF1=0
  - 07.OPF2=0
  - 08.CLS=1
  - 09.Serial interface
  - 10.VOUT=VIN(max 3.5V) x 2
  - 11.C1 connect 01.uF ~ 1uF(SMD)
  - 12.C2 connect 0.47uF ~ 2.2uF(SMD)

WO1602F APPLICATION FOR 3V / 4BIT INTERFACE

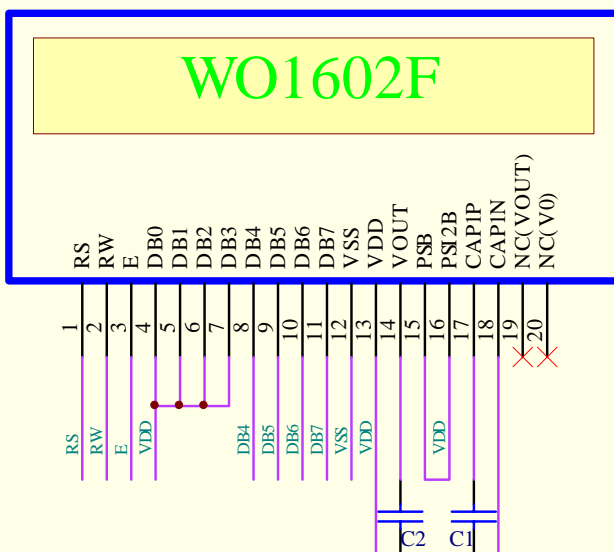

- ST7032i over Glass  
 Bon : set booster circuit on / FON = 1  
 Pin connection :
- 01.EXT=0
  - 02.OPR1=0
  - 03.OPR2=0
  - 04.SHLC=0
  - 05.SHLS=0
  - 06.OPF1=0
  - 07.OPF2=0
  - 08.CLS=1
  - 09.4BIT interface
  - 10.VOUT=VIN(max 3.5V) x 2
  - 11.C1 connect 01.uF ~ 1uF(SMD)
  - 12.C2 connect 0.47uF ~ 2.2uF(SMD)

WO1602F APPLICATION FOR 3V / 8BIT INTERFACE

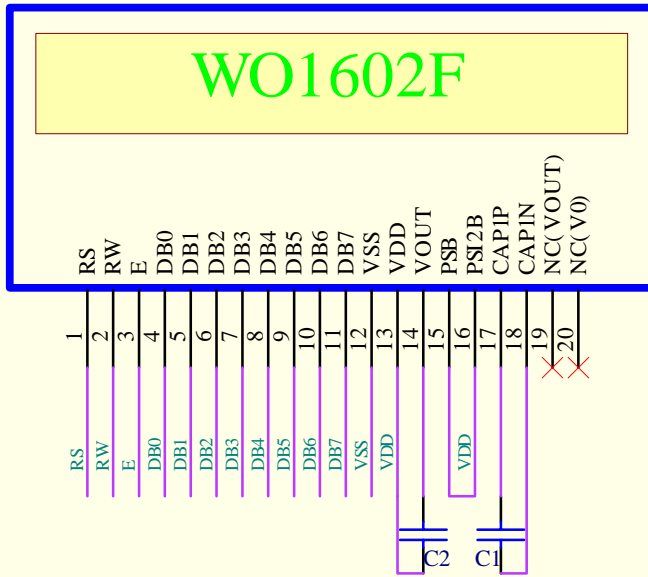

ST7032i over Glass  
 Bon : set booster circuit on FON = 1  
 Pin connection :  
 01.EXT=0  
 02.OPR1=0  
 03.OPR2=0  
 04.SHLC=0  
 05.SHLS=0  
 06.OPF1=0  
 07.OPF2=0  
 08.CLS=1  
 09.8BIT interface  
 10.VOUT=VIN(max 3.5V) x 2  
 11.C1 connect 01.uF ~ 1uF(SMD)  
 12.C2 connect 0.47uF ~ 2.2uF(SMD)

WO1602F APPLICATION FOR 3V / IIC INTERFACE

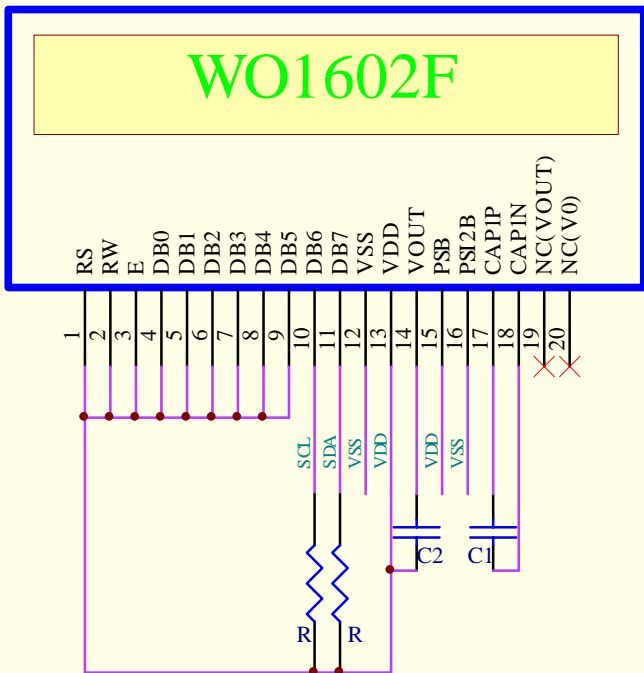

ST7032i over Glass  
 Bon : set booster circuit on / FON = 1  
 Pin connection :  
 01.EXT=0  
 02.OPR1=0  
 03.OPR2=0  
 04.SHLC=0  
 05.SHLS=0  
 06.OPF1=0  
 07.OPF2=0  
 08.CLS=1  
 09.IIC interface  
 10.VOUT=VIN(max 3.5V) x 2  
 11.C1 connect 01.uF ~ 1uF(SMD)  
 12.C2 connect 0.47uF ~ 2.2uF(SMD)

WO1602F APPLICATION FOR 5V/ Serial INTERFACE

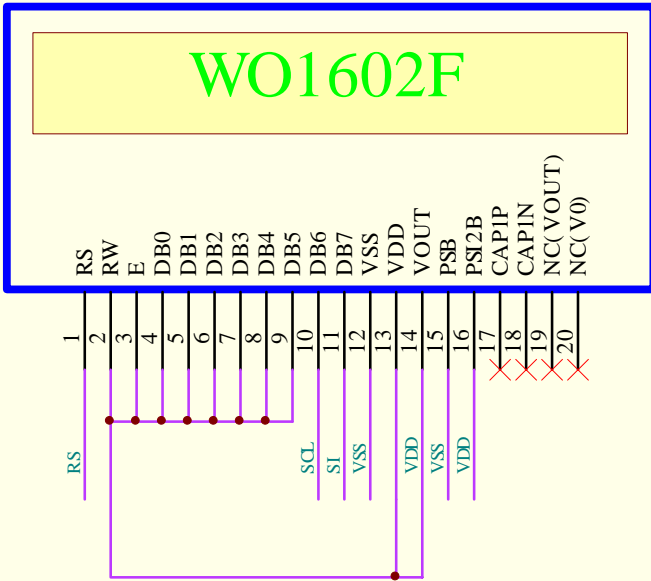

ST7032i over Glass  
 Bon : set booster circuit OFF/ FON =1  
 Pin connection :  
 01.EXT=0  
 02.OPR1=0  
 03.OPR2=0  
 04.SHLC=0  
 05.SHLS=0  
 06.OPF1=0  
 07.OPF2=0  
 08.CLS=1  
 09.Serial interface  
 10.VOUT=VDD(max 5.5V)

WO1602F APPLICATION FOR 5V/ 4BIT INTERFACE

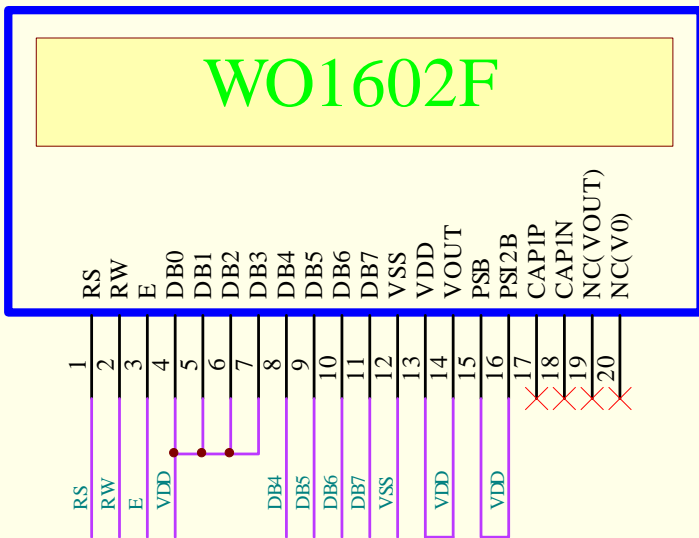

ST7032i over Glass  
 Bon : set booster circuit OFF/ FON = 1  
 Pin connection :  
 01.EXT=0  
 02.OPR1=0  
 03.OPR2=0  
 04.SHLC=0  
 05.SHLS=0  
 06.OPF1=0  
 07.OPF2=0  
 08.CLS=1  
 09.4BIT interface  
 10.VOUT=VDD(max 5.5V)

WO1602F APPLICATION FOR 5V / 8BIT INTERFACE

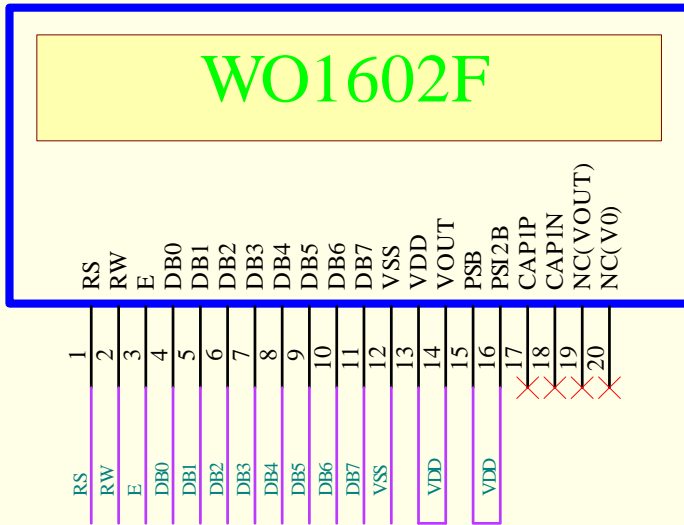

- ST7032i over Glass  
 Bon : set booster circuit OFF / FON = 1  
 Pin connection :
- 01.EXT=0
  - 02.OPR1=0
  - 03.OPR2=0
  - 04.SHLC=0
  - 05.SHLS=0
  - 06.OPF1=0
  - 07.OPF2=0
  - 08.CLS=1
  - 09.8BIT interface
  - 10.VOUT=VDD(max 5.5V)

WO1602F APPLICATION FOR 5V / IC INTERFACE

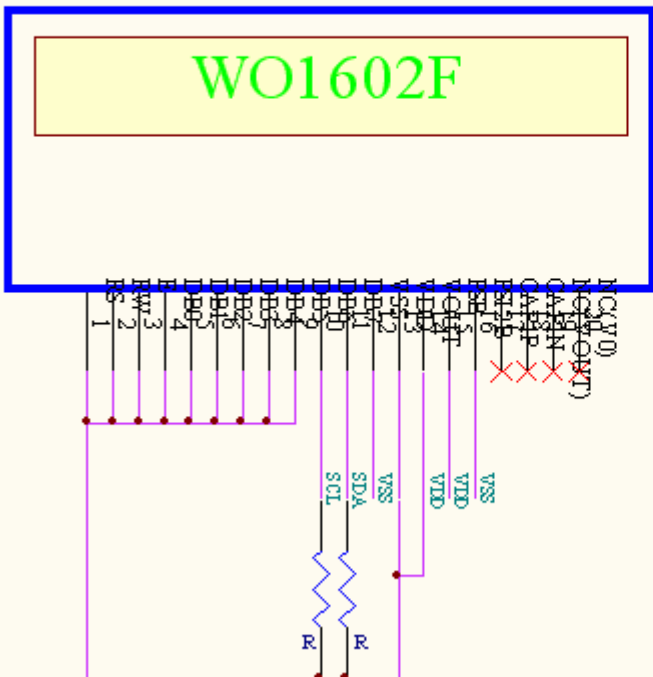

- ST7032i over Glass  
 Bon : set booster circuit OFF / FON = 1  
 Pin connection :
- 01.EXT=0
  - 02.OPR1=0
  - 03.OPR2=0
  - 04.SHLC=0
  - 05.SHLS=0
  - 06.OPF1=0
  - 07.OPF2=0
  - 08.CLS=1
  - 09.IIC interface
  - 10.VOUT=VDD(max 5.5V)

# 11. Reliability

## Content of Reliability Test (wide temperature, -20°C~70°C)

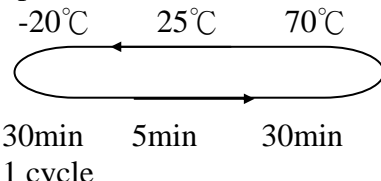
Environmental Test			
Test Item	Content of Test	Test Condition	Note
High Temperature storage	Endurance test applying the high storage temperature for a long time.	80°C 200hrs	2
Low Temperature storage	Endurance test applying the high storage temperature for a long time.	-30°C 200hrs	1,2
High Temperature Operation	Endurance test applying the electric stress (Voltage & Current) and the thermal stress to the element for a long time.	70°C 200hrs	—
Low Temperature Operation	Endurance test applying the electric stress under low temperature for a long time.	-20°C 200hrs	1
High Temperature/ Humidity Operation	The module should be allowed to stand at 60°C, 90%RH max For 96hrs under no-load condition excluding the polarizer, Then taking it out and drying it at normal temperature.	60°C, 90%RH 96hrs	1,2
Thermal shock resistance	The sample should be allowed stand the following 10 cycles of operation  <p style="text-align: center;">-20°C      25°C      70°C</p> <p style="text-align: center;">30min    5min    30min</p> <p style="text-align: center;">1 cycle</p>	-20°C/70°C 10 cycles	—
Vibration test	Endurance test applying the vibration during transportation and using.	Total fixed amplitude : 1.5mm Vibration Frequency : 10~55Hz One cycle 60 seconds to 3 directions of X,Y,Z for Each 15 minutes	3
Static electricity test	Endurance test applying the electric stress to the terminal.	VS=800V,RS=1.5kΩ CS=100pF 1 time	—

**Note1: No dew condensation to be observed.**

**Note2: The function test shall be conducted after 4 hours storage at the normal Temperature and humidity after remove from the test chamber.**

**Note3: Vibration test will be conducted to the product itself without putting it in a container.**



# 12.Backlight Information

## Specification

PARAMETER	SYMBOL	MIN	TYP	MAX	UNIT	TEST CONDITION
Supply Current	I <sub>LED</sub>	13.6	16	25	mA	V=3.5V
Supply Voltage	V	3.4	3.5	3.6	V	
Reverse Voltage	V <sub>R</sub>	—	—	5	V	—
Luminous Intensity (Without LCD)	I <sub>V</sub>	158.4	198	—	CD/M <sup>2</sup>	I <sub>LED</sub> =16mA
Wave Length	X	0.26	0.28	0.3		I <sub>LED</sub> =16mA
	Y	0.28	0.3	0.32		
LED Life Time	—	—	50000	—	Hr.	I <sub>LED</sub> ≤ 16mA
Color	White					

**Note:** The LED of B/L is drive by current only ; driving voltage is only for reference  
 To make driving current in safety area (waste current between minimum and maximum).

**Note1 :**50K hours is only an estimate for reference.

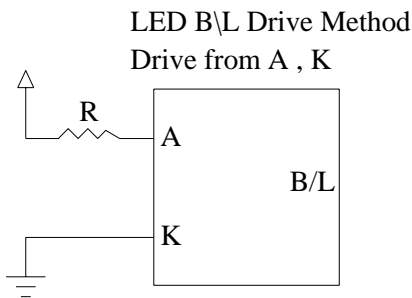

# 13. Inspection specification

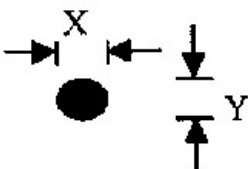
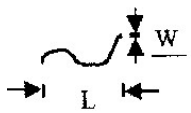
NO	Item	Criterion	AQL													
01	Electrical Testing	1.1 Missing vertical, horizontal segment, segment contrast defect. 1.2 Missing character , dot or icon. 1.3 Display malfunction. 1.4 No function or no display. 1.5 Current consumption exceeds product specifications. 1.6 LCD viewing angle defect. 1.7 Mixed product types. 1.8 Contrast defect.	0.65													
02	Black or white spots on LCD (display only)	2.1 White and black spots on display $\leq 0.25\text{mm}$ , no more than three white or black spots present. 2.2 Densely spaced: No more than two spots or lines within 3mm	2.5													
03	LCD black spots, white spots, contamination (non-display)	3.1 Round type : As following drawing $\Phi = (x + y) / 2$  <table border="1" data-bbox="874 1041 1353 1294"> <thead> <tr> <th>SIZE</th> <th>Acceptable Q TY</th> </tr> </thead> <tbody> <tr> <td><math>\Phi \leq 0.10</math></td> <td>Accept no dense</td> </tr> <tr> <td><math>0.10 &lt; \Phi \leq 0.20</math></td> <td>2</td> </tr> <tr> <td><math>0.20 &lt; \Phi \leq 0.25</math></td> <td>1</td> </tr> <tr> <td><math>0.25 &lt; \Phi</math></td> <td>0</td> </tr> </tbody> </table>	SIZE	Acceptable Q TY	$\Phi \leq 0.10$	Accept no dense	$0.10 < \Phi \leq 0.20$	2	$0.20 < \Phi \leq 0.25$	1	$0.25 < \Phi$	0	2.5			
		SIZE	Acceptable Q TY													
$\Phi \leq 0.10$	Accept no dense															
$0.10 < \Phi \leq 0.20$	2															
$0.20 < \Phi \leq 0.25$	1															
$0.25 < \Phi$	0															
3.2 Line type : (As following drawing)  <table border="1" data-bbox="710 1400 1353 1646"> <thead> <tr> <th>Length</th> <th>Width</th> <th>Acceptable Q TY</th> </tr> </thead> <tbody> <tr> <td>---</td> <td><math>W \leq 0.02</math></td> <td>Accept no dense</td> </tr> <tr> <td><math>L \leq 3.0</math></td> <td><math>0.02 &lt; W \leq 0.03</math></td> <td rowspan="2">2</td> </tr> <tr> <td><math>L \leq 2.5</math></td> <td><math>0.03 &lt; W \leq 0.05</math></td> </tr> <tr> <td>---</td> <td><math>0.05 &lt; W</math></td> <td>As round type</td> </tr> </tbody> </table>	Length	Width	Acceptable Q TY	---	$W \leq 0.02$	Accept no dense	$L \leq 3.0$	$0.02 < W \leq 0.03$	2	$L \leq 2.5$	$0.03 < W \leq 0.05$	---	$0.05 < W$	As round type	2.5	
Length	Width	Acceptable Q TY														
---	$W \leq 0.02$	Accept no dense														
$L \leq 3.0$	$0.02 < W \leq 0.03$	2														
$L \leq 2.5$	$0.03 < W \leq 0.05$															
---	$0.05 < W$	As round type														
04	Polarizer bubbles	If bubbles are visible, judge using black spot specifications, not easy to find, must check in specify direction.	<table border="1" data-bbox="842 1697 1353 1993"> <thead> <tr> <th>Size <math>\Phi</math></th> <th>Acceptable Q TY</th> </tr> </thead> <tbody> <tr> <td><math>\Phi \leq 0.20</math></td> <td>Accept no dense</td> </tr> <tr> <td><math>0.20 &lt; \Phi \leq 0.50</math></td> <td>3</td> </tr> <tr> <td><math>0.50 &lt; \Phi \leq 1.00</math></td> <td>2</td> </tr> <tr> <td><math>1.00 &lt; \Phi</math></td> <td>0</td> </tr> <tr> <td><b>Total Q TY</b></td> <td><b>3</b></td> </tr> </tbody> </table>	Size $\Phi$	Acceptable Q TY	$\Phi \leq 0.20$	Accept no dense	$0.20 < \Phi \leq 0.50$	3	$0.50 < \Phi \leq 1.00$	2	$1.00 < \Phi$	0	<b>Total Q TY</b>	<b>3</b>	2.5
Size $\Phi$	Acceptable Q TY															
$\Phi \leq 0.20$	Accept no dense															
$0.20 < \Phi \leq 0.50$	3															
$0.50 < \Phi \leq 1.00$	2															
$1.00 < \Phi$	0															
<b>Total Q TY</b>	<b>3</b>															

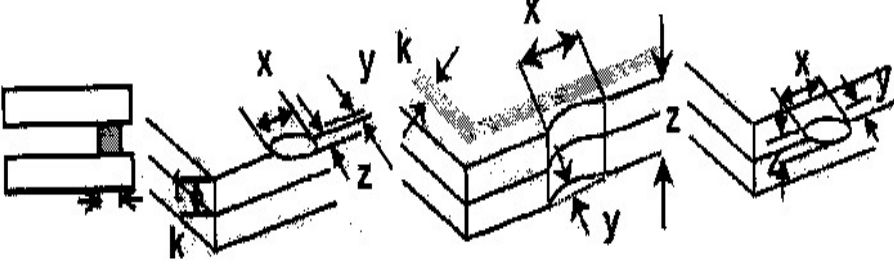
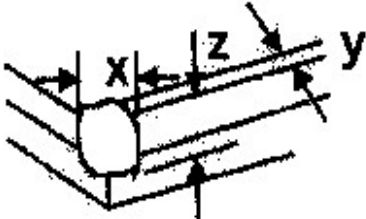
NO	Item	Criterion	AQL																		
05	Scratches	Follow NO.3 LCD black spots, white spots, contamination																			
06	Chipped glass	<p>Symbols Define:  x: Chip length      y: Chip width      z: Chip thickness  k: Seal width      t: Glass thickness      a: LCD side length  L: Electrode pad length:</p> <p>6.1 General glass chip :  6.1.1 Chip on panel surface and crack between panels:</p>  <table border="1" data-bbox="421 945 1318 1137"> <thead> <tr> <th>z: Chip thickness</th> <th>y: Chip width</th> <th>x: Chip length</th> </tr> </thead> <tbody> <tr> <td><math>Z \leq 1/2t</math></td> <td>Not over viewing area</td> <td><math>x \leq 1/8a</math></td> </tr> <tr> <td><math>1/2t &lt; z \leq 2t</math></td> <td>Not exceed 1/3k</td> <td><math>x \leq 1/8a</math></td> </tr> </tbody> </table> <p>⊙If there are 2 or more chips, x is total length of each chip.</p> <p>6.1.2 Corner crack:</p>  <table border="1" data-bbox="421 1532 1318 1724"> <thead> <tr> <th>z: Chip thickness</th> <th>y: Chip width</th> <th>x: Chip length</th> </tr> </thead> <tbody> <tr> <td><math>Z \leq 1/2t</math></td> <td>Not over viewing area</td> <td><math>x \leq 1/8a</math></td> </tr> <tr> <td><math>1/2t &lt; z \leq 2t</math></td> <td>Not exceed 1/3k</td> <td><math>x \leq 1/8a</math></td> </tr> </tbody> </table> <p>⊙If there are 2 or more chips, x is the total length of each chip.</p>	z: Chip thickness	y: Chip width	x: Chip length	$Z \leq 1/2t$	Not over viewing area	$x \leq 1/8a$	$1/2t < z \leq 2t$	Not exceed 1/3k	$x \leq 1/8a$	z: Chip thickness	y: Chip width	x: Chip length	$Z \leq 1/2t$	Not over viewing area	$x \leq 1/8a$	$1/2t < z \leq 2t$	Not exceed 1/3k	$x \leq 1/8a$	2.5
z: Chip thickness	y: Chip width	x: Chip length																			
$Z \leq 1/2t$	Not over viewing area	$x \leq 1/8a$																			
$1/2t < z \leq 2t$	Not exceed 1/3k	$x \leq 1/8a$																			
z: Chip thickness	y: Chip width	x: Chip length																			
$Z \leq 1/2t$	Not over viewing area	$x \leq 1/8a$																			
$1/2t < z \leq 2t$	Not exceed 1/3k	$x \leq 1/8a$																			

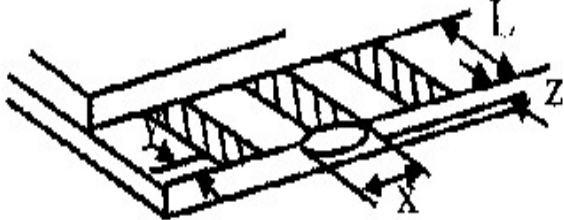
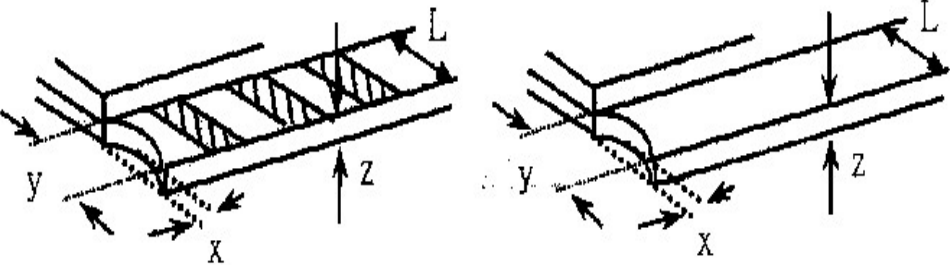
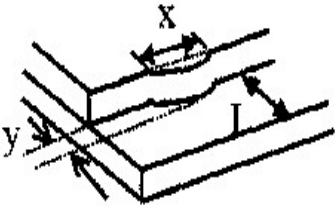
NO	Item	Criterion	AQL																
06	Glass crack	<p>Symbols :</p> <p>x: Chip length      y: Chip width      z: Chip thickness  k: Seal width      t: Glass thickness      a: LCD side length  L: Electrode pad length</p> <p>6.2 Protrusion over terminal :</p> <p>6.2.1 Chip on electrode pad :</p>  <table border="1" data-bbox="355 703 1265 790"> <tr> <td>y: Chip width</td> <td>x: Chip length</td> <td>z: Chip thickness</td> </tr> <tr> <td><math>y \leq 0.5\text{mm}</math></td> <td><math>x \leq 1/8a</math></td> <td><math>0 &lt; z \leq t</math></td> </tr> </table> <p>6.2.2 Non-conductive portion:</p>  <table border="1" data-bbox="427 1122 1265 1209"> <tr> <td>y: Chip width</td> <td>x: Chip length</td> <td>z: Chip thickness</td> </tr> <tr> <td><math>y \leq L</math></td> <td><math>x \leq 1/8a</math></td> <td><math>0 &lt; z \leq t</math></td> </tr> </table> <p>⊙ If the chipped area touches the ITO terminal, over 2/3 of the ITO must remain and be inspected according to electrode terminal specifications.</p> <p>⊙ If the product will be heat sealed by the customer, the alignment mark not be damaged.</p> <p>6.2.3 Substrate protuberance and internal crack.</p>  <table border="1" data-bbox="762 1435 1270 1523"> <tr> <td>y: width</td> <td>x: length</td> </tr> <tr> <td><math>y \leq 1/3L</math></td> <td><math>x \leq a</math></td> </tr> </table>	y: Chip width	x: Chip length	z: Chip thickness	$y \leq 0.5\text{mm}$	$x \leq 1/8a$	$0 < z \leq t$	y: Chip width	x: Chip length	z: Chip thickness	$y \leq L$	$x \leq 1/8a$	$0 < z \leq t$	y: width	x: length	$y \leq 1/3L$	$x \leq a$	2.5
y: Chip width	x: Chip length	z: Chip thickness																	
$y \leq 0.5\text{mm}$	$x \leq 1/8a$	$0 < z \leq t$																	
y: Chip width	x: Chip length	z: Chip thickness																	
$y \leq L$	$x \leq 1/8a$	$0 < z \leq t$																	
y: width	x: length																		
$y \leq 1/3L$	$x \leq a$																		

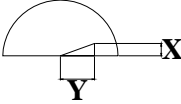
NO	Item	Criterion	AQL
07	Cracked glass	The LCD with extensive crack is not acceptable.	2.5
08	Backlight elements	8.1 Illumination source flickers when lit. 8.2 Spots or scratched that appear when lit must be judged. Using LCD spot, lines and contamination standards. 8.3 Backlight doesn't light or color wrong.	0.65 2.5 0.65
09	Bezel	9.1 Bezel may not have rust, be deformed or have fingerprints, stains or other contamination. 9.2 Bezel must comply with job specifications.	2.5 0.65
10	PCB 、 COB	10.1 COB seal may not have pinholes larger than 0.2mm or contamination. 10.2 COB seal surface may not have pinholes through to the IC. 10.3 The height of the COB should not exceed the height indicated in the assembly diagram. 10.4 There may not be more than 2mm of sealant outside the seal area on the PCB. And there should be no more than three places. 10.5 No oxidation or contamination PCB terminals. 10.6 Parts on PCB must be the same as on the production characteristic chart. There should be no wrong parts, missing parts or excess parts. 10.7 The jumper on the PCB should conform to the product characteristic chart. 10.8 If solder gets on bezel tab pads, LED pad, zebra pad or screw hold pad, make sure it is smoothed down. 10.9 The Scraping testing standard for Copper Coating of PCB  $X * Y \leq 2mm^2$	2.5 2.5 0.65 2.5 2.5 0.65 2.5 2.5
11	Soldering	11.1 No un-melted solder paste may be present on the PCB. 11.2 No cold solder joints, missing solder connections, oxidation or icicle. 11.3 No residue or solder balls on PCB. 11.4 No short circuits in components on PCB.	2.5 2.5 2.5 0.65

NO	Item	Criterion	AQL
12	General appearance	12.1 No oxidation, contamination, curves or, bends on interface Pin (OLB) of TCP.	2.5
		12.2 No cracks on interface pin (OLB) of TCP.	0.65
		12.3 No contamination, solder residue or solder balls on product.	2.5
		12.4 The IC on the TCP may not be damaged, circuits.	2.5
		12.5 The uppermost edge of the protective strip on the interface pin must be present or look as if it cause the interface pin to sever.	2.5
		12.6 The residual rosin or tin oil of soldering (component or chip component) is not burned into brown or black color.	2.5
		12.7 Sealant on top of the ITO circuit has not hardened.	0.65
		12.8 Pin type must match type in specification sheet.	0.65
		12.9 LCD pin loose or missing pins.	0.65
		12.10 Product packaging must the same as specified on packaging specification sheet.	0.65
		12.11 Product dimension and structure must conform to product specification sheet.	

# 14. Material List of Components for RoHs

1. WINSTAR Display Co., Ltd hereby declares that all of or part of products (with the mark “#”in code), including, but not limited to, the LCM, accessories or packages, manufactured and/or delivered to your company (including your subsidiaries and affiliated company) directly or indirectly by our company (including our subsidiaries or affiliated companies) do not intentionally contain any of the substances listed in all applicable EU directives and regulations, including the following substances.

Exhibit A : The Harmful Material List

Material	(Cd)	(Pb)	(Hg)	(Cr6+)	PBBs	PBDEs
Limited Value	100 ppm	1000 ppm	1000 ppm	1000 ppm	1000 ppm	1000 ppm
Above limited value is set up according to RoHS.						

2.Process for RoHS requirement :

(1) Use the Sn/Ag/Cu soldering surface ; the surface of Pb-free solder is rougher than we used before.

(2) Heat-resistance temp. :

Reflow : 250°C,30 seconds Max. ;

Connector soldering wave or hand soldering : 320°C, 10 seconds max.

(3) Temp. curve of reflow, max. Temp. : 235±5°C ;

Recommended customer’s soldering temp. of connector : 280°C, 3 seconds.



**1、Panel Specification :**

- 1. Panel Type :  Pass  NG , \_\_\_\_\_
- 2. View Direction :  Pass  NG , \_\_\_\_\_
- 3. Numbers of Dots :  Pass  NG , \_\_\_\_\_
- 4. View Area :  Pass  NG , \_\_\_\_\_
- 5. Active Area :  Pass  NG , \_\_\_\_\_
- 6. Operating Temperature :  Pass  NG , \_\_\_\_\_
- 7. Storage Temperature :  Pass  NG , \_\_\_\_\_
- 8. Others : \_\_\_\_\_

**2、Mechanical Specification :**

- 1. PCB Size :  Pass  NG , \_\_\_\_\_
- 2. Frame Size :  Pass  NG , \_\_\_\_\_
- 3. Material of Frame :  Pass  NG , \_\_\_\_\_
- 4. Connector Position :  Pass  NG , \_\_\_\_\_
- 5. Fix Hole Position : A  Pass  NG , \_\_\_\_\_
- 6. Backlight Position :  Pass  NG , \_\_\_\_\_
- 7. Thickness of PCB :  Pass  NG , \_\_\_\_\_
- 8. Height of Frame to PCB :  Pass  NG , \_\_\_\_\_
- 9. Height of Module :  Pass  NG , \_\_\_\_\_
- 10. Others :  Pass  NG , \_\_\_\_\_

**3、Relative Hole Size :**

- 1. Pitch of Connector :  Pass  NG , \_\_\_\_\_
- 2. Hole size of Connector :  Pass  NG , \_\_\_\_\_
- 3. Mounting Hole size :  Pass  NG , \_\_\_\_\_
- 4. Mounting Hole Type :  Pass  NG , \_\_\_\_\_
- 5. Others :  Pass  NG , \_\_\_\_\_

**4、Backlight Specification :**

- 1. B/L Type :  Pass  NG , \_\_\_\_\_
- 2. B/L Color :  Pass  NG , \_\_\_\_\_
- 3. B/L Driving Voltage (Reference for LED Type) :  Pass  NG , \_\_\_\_\_
- 4. B/L Driving Current :  Pass  NG , \_\_\_\_\_
- 5. Brightness of B/L :  Pass  NG , \_\_\_\_\_
- 6. B/L Solder Method :  Pass  NG , \_\_\_\_\_
- 7. Others :  Pass  NG , \_\_\_\_\_

>> **Go to page 2** <<





Module Number : \_\_\_\_\_

**5、Electronic Characteristics of Module :**

- 1. Input Voltage :  Pass  NG , \_\_\_\_\_
- 2. Supply Current :  Pass  NG , \_\_\_\_\_
- 3. Driving Voltage for LCD :  Pass  NG , \_\_\_\_\_
- 4. Contrast for LCD :  Pass  NG , \_\_\_\_\_
- 5. B/L Driving Method :  Pass  NG , \_\_\_\_\_
- 6. Negative Voltage Output :  Pass  NG , \_\_\_\_\_
- 7. Interface Function :  Pass  NG , \_\_\_\_\_
- 8. LCD Uniformity :  Pass  NG , \_\_\_\_\_
- 9. ESD test :  Pass  NG , \_\_\_\_\_
- 10. Others :  Pass  NG , \_\_\_\_\_

**6、Summary :**

Sales signature : \_\_\_\_\_

Customer Signature : \_\_\_\_\_

Date :    /    /