



Winstar Display Co., LTD

華凌光電股份有限公司



住址: 407 台中市中清路 163 號
No.163 Chung Ching RD.,
Taichune, Taiwan, R.O.C

WEB: <http://www.winstar.com.tw>
E-mail: sales@winstar.com.tw
Tel:886-4-24262208 Fax : 886-4-24262207



SPECIFICATION

CUSTOMER : _____

MODULE NO.: WO2004A-TFH#

APPROVED BY: (FOR CUSTOMER USE ONLY)	PCB VERSION:	DATA:

SALES BY	APPROVED BY	CHECKED BY	PREPARED BY

VERSION	DATE	REVISED PAGE NO.	SUMMARY
0	2011.11.08		First issue

MODLE NO :

RECORDS OF REVISION

DOC. FIRST ISSUE

VERSION	DATE	REVISED PAGE NO.	SUMMARY
0	2011.11.08		First issue

Contents

1. Module Classification Information
2. Precautions in use of LCD Modules
3. General Specification
4. Absolute Maximum Ratings
5. Electrical Characteristics
6. Optical Characteristics
7. Interface Pin Function
8. Contour Drawing
9. Function Block Descriptions
10. Reliability
11. Backlight Information
12. Inspection specification
13. Material List of Components for RoHs
14. Recommendable storage

1.Module Classification Information

W O 2004 A— T F H #
 ① ② ③ ④ ⑤ ⑥ ⑦ ⑧

- ① Brand : WINSTAR DISPLAY CORPORATION
- ② Display Type : H→Character Type, G→Graphic Type O→COG Type
- ③ Display Font : 20 x 04 dots
- ④ Model serials no.
- ⑤ Backlight Type : N→Without backlight T→LED, White
 B→EL, Blue green A→LED, Amber
 D→EL, Green R→LED, Red
 W→EL, White O→LED, Orange
 F→CCFL, White G→LED, Green
 Y→LED, Yellow Green P→LED, Blue
- ⑥ LCD Mode : B→TN Positive, Gray T→FSTN Negative
 N→TN Negative,
 G→STN Positive, Gray
 Y→STN Positive, Yellow Green
 M→STN Negative, Blue
 F→FSTN Positive
- ⑦ LCD Polarize A→Reflective, N.T, 6:00 H→Transflective, W.T,6:00
 Type/ Temperature D→Reflective, N.T, 12:00 K→Transflective, W.T,12:00
 range/ View G→Reflective, W. T, 6:00 C→Transmissive, N.T,6:00
 direction J→Reflective, W. T, 12:00 F→Transmissive, N.T,12:00
 B→Transflective, N.T,6:00 I→Transmissive, W. T, 6:00
 E→Transflective, N.T,12:00 L→Transmissive, W.T,12:00
- ⑧ Special Code #:Fit in with the ROHS Directions and regulations

2.Precautions in use of LCD Modules

- (1) Avoid applying excessive shocks to the module or making any alterations or modifications to it.
- (2) Don't make extra holes on the printed circuit board, modify its shape or change the components of LCD module.
- (3) Don't disassemble the LCM.
- (4) Don't operate it above the absolute maximum rating.
- (5) Don't drop, bend or twist LCM.
- (6) Soldering: only to the I/O terminals.
- (7) Storage: please storage in anti-static electricity container and clean environment.
- (8) Winstar have the right to change the passive components, including R3,R6 & backlight adjust resistors. (Resistors, capacitors and other passive components will have different appearance and color caused by the different supplier.)
- (9) Winstar have the right to change the PCB Rev. (In order to satisfy the supplying stability, management optimization and the best product performance...etc, under the premise of not affecting the electrical characteristics and external dimensions, Winstar have the right to modify the version.)

3.General Specification

Item	Dimension	Unit
Module dimension	74.3x 36.4x 6.0(MAX)	mm
View area	60.5 x 22.18	mm
Active area	58.5 x 20.18	mm
Dot size	0.45x 0.54	mm
Dot pitch	0.5 x 0.59	mm
Character size	2.45 x 4.67	mm
Character pitch	2.95 x 5.17	mm
LCD type	FSTN Positive Transflective, (In LCD production, It will occur slightly color difference. We can only guarantee the same color in the same batch.)	
Duty	1/33DUTY,1/6BIAS	
View direction	6 o'clock	
Backlight Type	LED, White	

4. Absolute Maximum Ratings

Item	Symbol	Min	Typ	Max	Unit
Operating Temperature	T_{OP}	-20	—	+70	°C
Storage Temperature	T_{ST}	-30	—	+80	°C
Power Supply Voltage	V_{DD}	-0.3	—	6.0	V
LCD Driver Voltage	VLCD	-0.3	—	15.0	V
Input Voltage	V_{IN}	-0.3	—	$V_{DD}+0.3$	V

5. Electrical Characteristics

Item	Symbol	Condition	Min	Typ	Max	Unit
Supply Voltage For Logic	V_{DDIO}	Low Voltage I/O App.	2.4	3.0	V_{DD}	V
		5V I/O App.	4.5	5.0	5.5	V
	V_{DD}	—	2.4	3.0	3.6	V
Supply Voltage For LCD	V_O-V_{SS}	$T_a=-20^{\circ}C$	—	—	—	V
		$T_a=25^{\circ}C$	—	7.8	—	V
		$T_a=70^{\circ}C$	—	—	—	V
Input High Volt.	V_{IH}	—	$0.8 V_{DDIO}$	—	V_{DDIO}	V
Input Low Volt.	V_{IL}	—	—	—	$0.2 V_{DDIO}$	V
Output High Volt.	V_{OH}	—	$0.8 V_{DDIO}$	—	V_{DDIO}	V
Output Low Volt.	V_{OL}	—	—	—	$0.2 V_{DDIO}$	V
Supply LCM current	IDD	VDD=5.0V	—	1.0	—	mA

6. Optical Characteristics

Item	Symbol	Condition	Min	Typ	Max	Unit
View Angle	(V) θ	$CR \geq 2$	30	—	60	deg
	(H) φ	$CR \geq 2$	-45	—	45	deg
Contrast Ratio	CR	—	—	5	—	—
Response Time	T rise	—	—	200	300	ms
	T fall	—	—	200	300	ms

Definition of Operation Voltage (Vop)

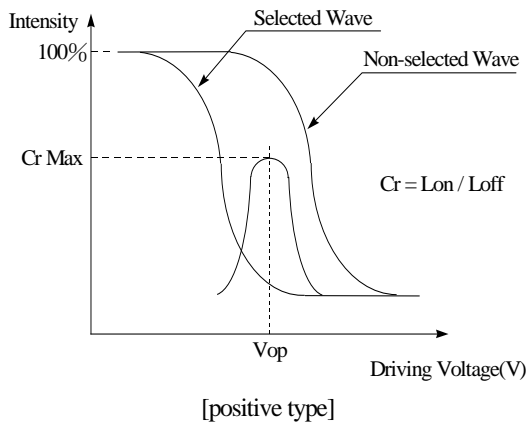

Definition of Response Time (Tr, Tf)

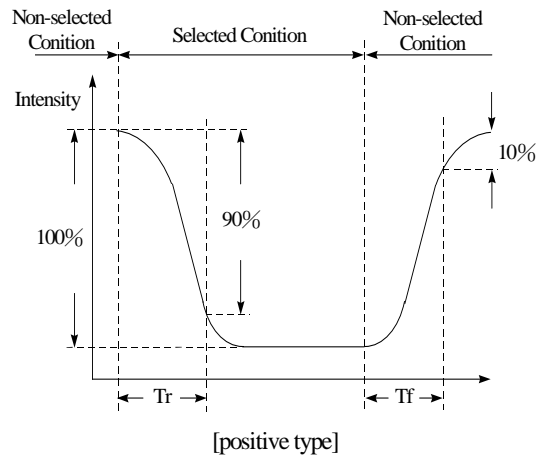

Conditions :

Operating Voltage : Vop Viewing Angle(θ , φ) : 0° , 0°
 Frame Frequency : 64 HZ Driving Waveform : 1/N duty , 1/a bias

Definition of viewing angle($CR \geq 2$)

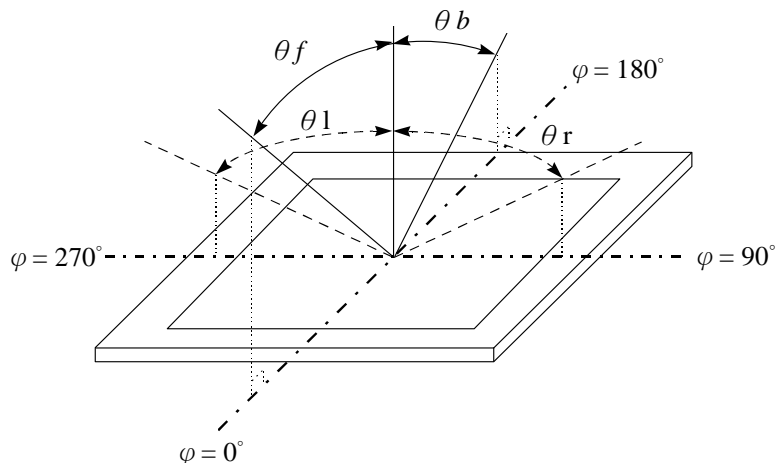

7. Interface Pin Function

Pin No.	Symbol	Description						
1	/RES	Reset Pin						
2	VOUT	Output of the voltage converter						
3	V0	Regulated voltage from voltage converter for LCD driving						
4	V1	Bias voltage levels for LCD driving						
5	V2							
6	V3							
7	V4							
8	VDD	This pin is the power supply for logic circuit (VDD should rise within 10ms). In 3V IO application (VDDREG pulled low), this is a power input pin. In 5V IO application (VDDREG pulled high), this pin outputs 3V and should be connected with a capacitor to VSS.						
9	VDDREG	This pin is used to enable VDD regulator in 5V I/O Application: <table border="1" style="margin-left: 20px;"> <thead> <tr> <th>VDDREG</th> <th>Mode</th> </tr> </thead> <tbody> <tr> <td>H</td> <td>5V I/O Application</td> </tr> <tr> <td>L</td> <td>Low Voltage I/O Application</td> </tr> </tbody> </table>	VDDREG	Mode	H	5V I/O Application	L	Low Voltage I/O Application
VDDREG	Mode							
H	5V I/O Application							
L	Low Voltage I/O Application							
10	VDDIO	This pin is the power supply for bus IO buffer in both Low Voltage I/O and 5V I/O application.						
11	VSS	Ground						
12	SCL	This pin is used as clock input pin in I2C mode.						
13	SDA	This pin is used as data/ acknowledge response output pin in I2C mode.						

8. Contour Drawing

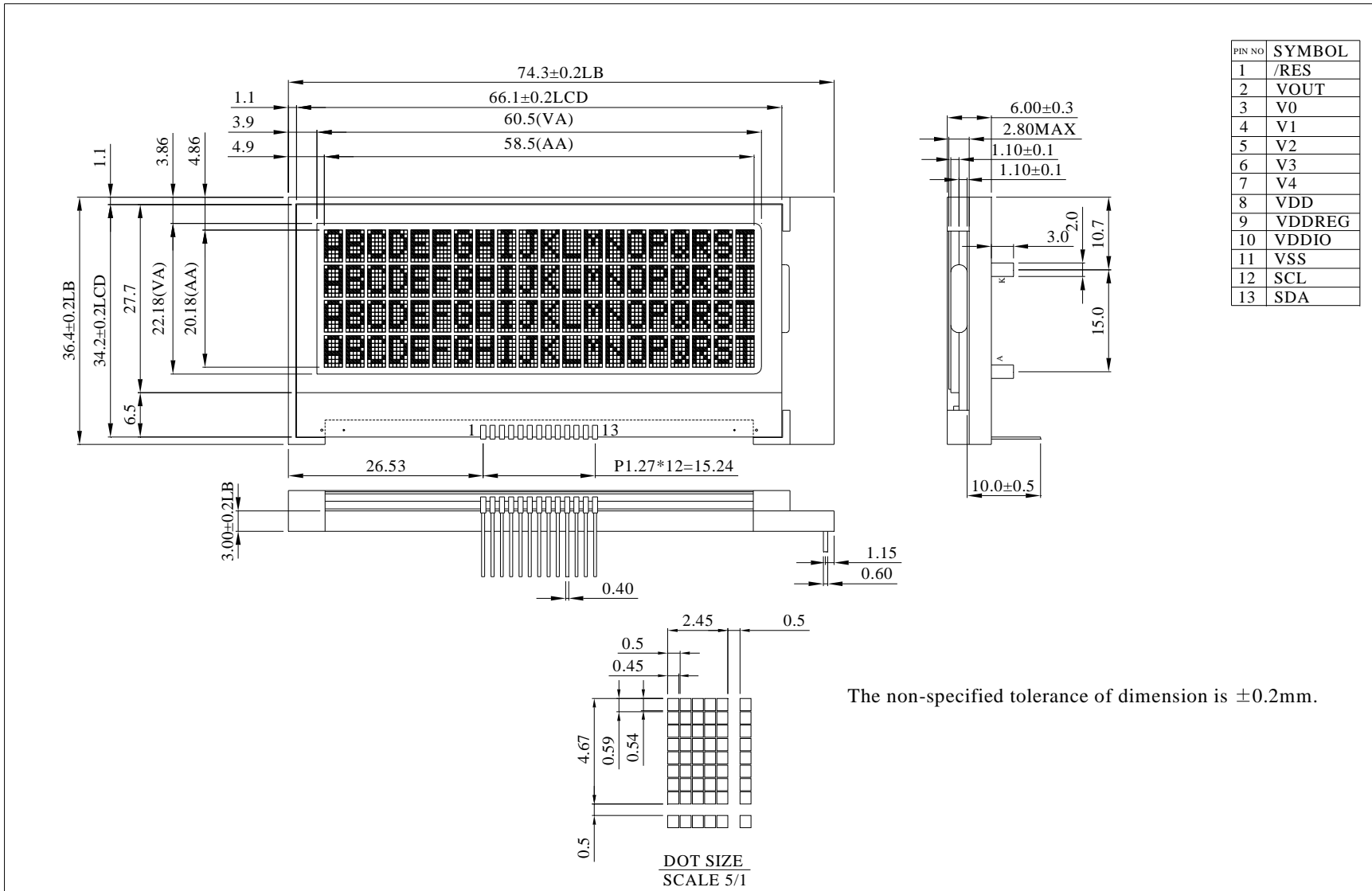

8.1 APPLICATION EXAMPLES

1. Application Example I (I2C interface, 3V VDDIO mode)

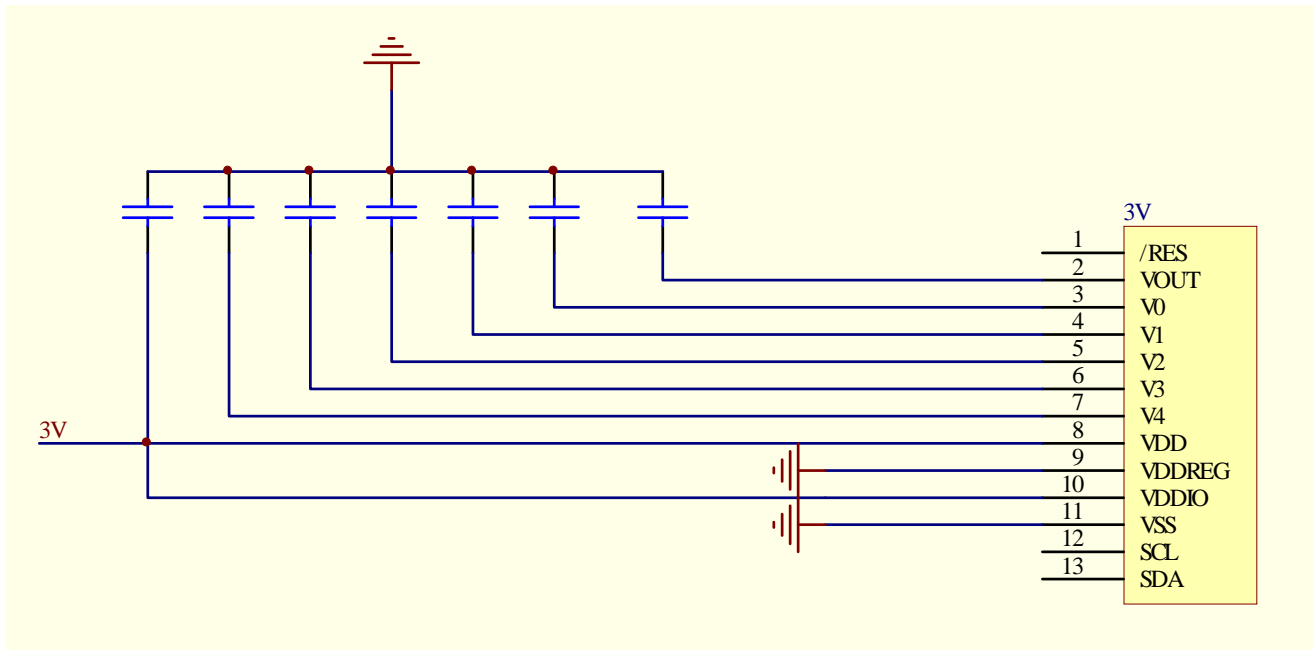

2. Application Example II (I2C interface, 5V IO mode)

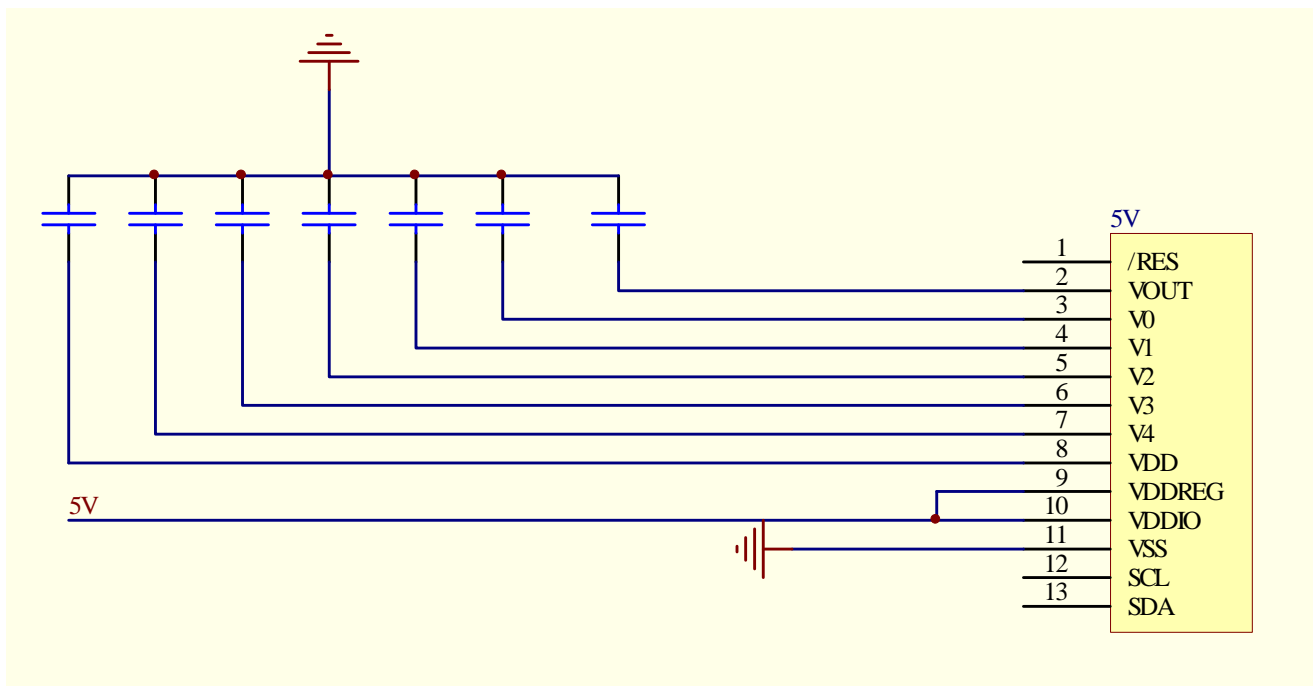

Capacitance = $1\mu\text{F}$

9. Function Block Descriptions

9.1 Busy Flag (BF)

When BF = "High", it indicates that the internal operation is being processed. So during this time the next instruction cannot be accepted. BF can be read, when RS = Low and R/W = High (Read Instruction Operation), through DB7. Before executing the next instruction, be sure that BF is not high.

9.2 Display Data Ram (DDRAM)

DDRAM stores display data of maximum 80 x 8 bits (80 characters). DDRAM address is set in the address counter (AC) as a hexadecimal number. (Refer to Figure 9-1)

Figure 9-1: DDRAM Address

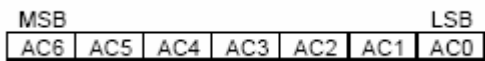

Display of 5-Dot Font Width Character

5-dot 4-line Display

In case of 4-line display with 5-dot font, the address range of DDARM is 00H-13H, 20H-33H, 40H-53H, 60H-73H (refer to Figure 9-5).

Figure 9-2: 4-line x 20ch. Display (5-dot Font Width)

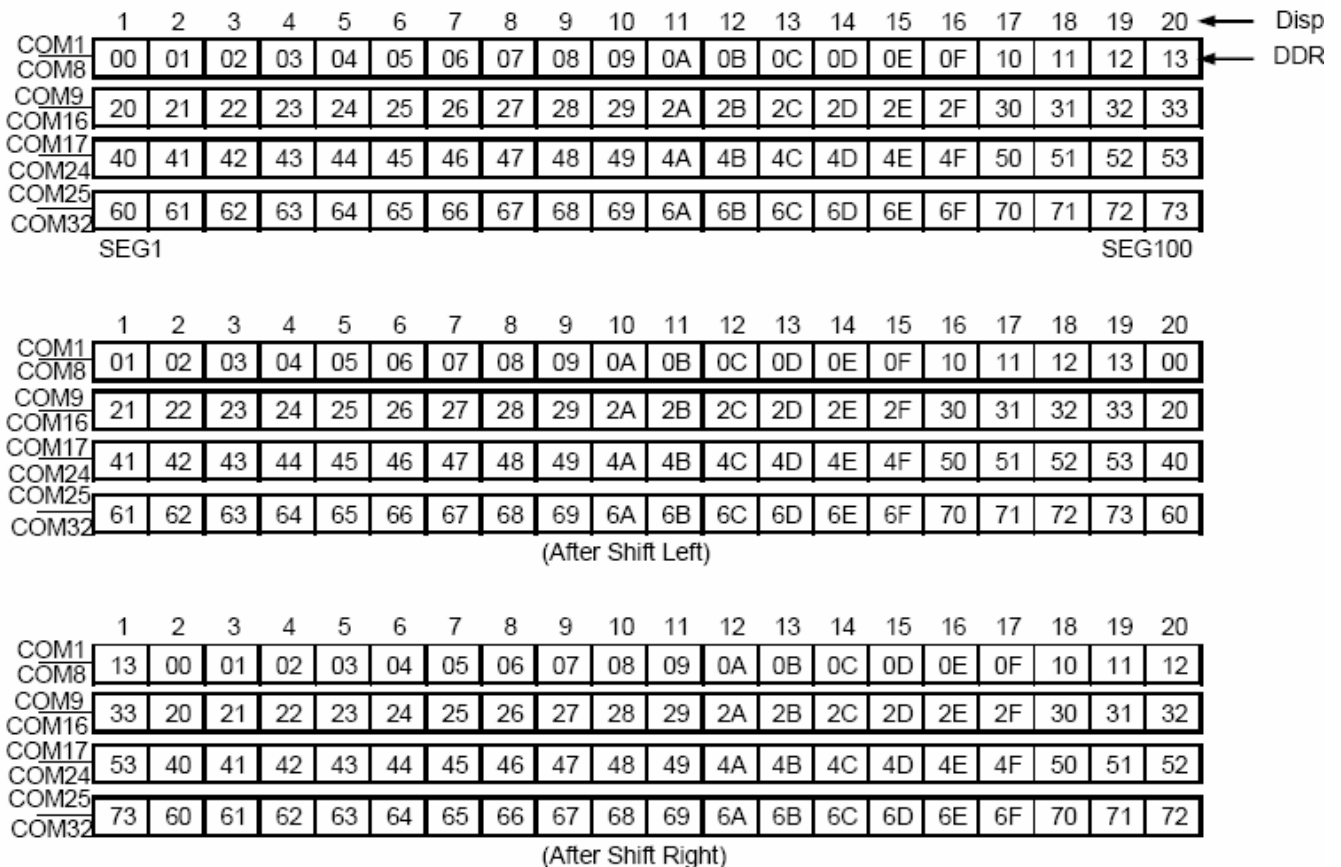

9.3 Timing Generation Circuit

Timing generation circuit generates clock signals for the internal operations.

9.4 Address Counter (AC)

Address Counter (AC) stores DDRAM/ CGRAM/ SEGRAM address, transferred from Instruction Register (IR). After writing into (reading from) DDRAM/ CGRAM/ SEGRAM, AC is automatically increased (decreased) by 1. In parallel and serial mode, when RS = "Low" and R/W = "High", AC can be read through DB0-DB6.

9.5 Cursor/Blink Control Circuit

It controls cursor/blink ON/OFF and black/white inversion at cursor position.

9.6 LCD Driver Circuit

LCD Driver circuit has 34 common and 100 segment signals for LCD driving. Data from SEGRAM/ CGRAM/ CGROM is transferred to 100-bit segment latch serially, and then it is stored to 100-bit shift latch. When each com is selected by 34-bit common register, segment data also output through segment driver from 100-bit segment latch. In case of 1-line display mode, ICON1/ICON2 and COM1-COM8 have 1/9 duty ratio; and in 4-line mode, ICON1/ICON2 and COM1-COM32 have 1/33 duty ratio.

9.7 CGROM (Character Generator ROM)

There is 3 optional CGROMs in SSD1803A in P.66-68 , which is selected by ROM1 and ROM2 pins. CGROM has 5 x 8 dots 256 Character Pattern.

9.8 CGRAM (Character Generator RAM)

CGRAM has up to 8 characters of 5 x 8 dots, selectable by OPR2 and OPR1 pins (refer to Table 9-1).

Table 9-1: CGRAM and CGROM arrangement with

$(OPR2, OPR1) = (0, 0)$

		b3-0															
		b7-4	0000	0001	0010	0011	0100	0101	0110	0111	1000	1001	1010	1011	1100	1101	1110
0000																	
0001																	

$(OPR2, OPR1) = (1, 0)$

		b3-0															
		b7-4	0000	0001	0010	0011	0100	0101	0110	0111	1000	1001	1010	1011	1100	1101	1110
0000																	
0001																	

$(OPR2, OPR1) = (0, 1)$

		b3-0															
		b7-4	0000	0001	0010	0011	0100	0101	0110	0111	1000	1001	1010	1011	1100	1101	1110
0000																	
0001																	

$(OPR2, OPR1) = (1, 1)$

		b3-0															
		b7-4	0000	0001	0010	0011	0100	0101	0110	0111	1000	1001	1010	1011	1100	1101	1110
0000																	
0001																	

By writing font data to CGRAM, user defined character can be used (refer to Table 9-2).

**Table 9-2: Relationship between Character Code (DDRAM) and Character Pattern (CGRAM)
5x8 dots Character Pattern**

Character Code (DDRAM Data)								CGRAM Address						CGRAM Data								Pattern Number
D7	D6	D5	D4	D3	D2	D1	D0	A5	A4	A3	A2	A1	A0	P7	P6	P5	P4	P3	P2	P1	P0	
0	0	0	0	x	0	0	0	0	0	0	0	0	0	B1	B0	x	0	1	1	1	0	Pattern1
				.							0	0	1				1	0	0	0	1	
				.							0	1	0				1	0	0	0	1	
				.							0	1	1				1	1	1	1	1	
				.							1	0	0				1	0	0	0	1	
				.							1	0	1				1	0	0	0	1	
				.							1	1	0				1	0	0	0	1	
				.							1	1	1				0	0	0	0	0	
0	0	0	0	x	1	1	1	1	1	1	0	0	0	B1	B0	x	1	0	0	0	1	Pattern8
				.							0	0	1				1	0	0	0	1	
				.							0	1	0				1	0	0	0	1	
				.							0	1	1				1	1	1	1	1	
				.							1	0	0				1	0	0	0	1	
				.							1	0	1				1	0	0	0	1	
				.							1	1	0				1	0	0	0	1	
				.							1	1	1				0	0	0	0	0	

7.9 SEGRAM (Segment Icon RAM)

SEGRAM has segment control data and segment pattern data. During display mode, ICON1 (ICON2) makes the data of SEGRAM enable to display icons. Its higher 2-bit are blinking control data, and lower 6-bits are pattern data (refer to Table 9-3 and Figure 9-3).

Table 9-3: Relationship between SEGRAM Address and Display Pattern

SEGRAM Address				SEGRAM Data Display Pattern															
				5-dot Font Width								6-dot Font Width							
A3	A2	A1	A0	D7	D6	D5	D4	D3	D2	D1	D0	D7	D6	D5	D4	D3	D2	D1	D0
0	0	0	0	B1	B0	X	S1	S2	S3	S4	S5	B1	B0	S1	S2	S3	S4	S5	S6
0	0	0	1	B1	B0	X	S6	S7	S8	S9	S10	B1	B0	S7	S8	S9	S10	S11	S12
0	0	1	0	B1	B0	X	S11	S12	S13	S14	S15	B1	B0	S13	S14	S15	S16	S17	S18
0	0	1	1	B1	B0	X	S16	S17	S18	S19	S20	B1	B0	S19	S20	S21	S22	S23	S24
0	1	0	0	B1	B0	X	S21	S22	S23	S24	S25	B1	B0	S25	S26	S27	S28	S29	S30
0	1	0	1	B1	B0	X	S26	S27	S28	S29	S30	B1	B0	S31	S32	S33	S34	S35	S36
0	1	1	0	B1	B0	X	S31	S32	S33	S34	S35	B1	B0	S37	S38	S39	S40	S41	S42
0	1	1	1	B1	B0	X	S36	S37	S38	S39	S40	B1	B0	S43	S44	S45	S46	S47	S48
1	0	0	0	B1	B0	X	S41	S42	S43	S44	S45	B1	B0	S49	S50	S51	S52	S53	S54
1	0	0	1	B1	B0	X	S46	S47	S48	S49	S50	B1	B0	S55	S56	S57	S58	S59	S60
1	0	1	0	B1	B0	X	S51	S52	S53	S54	S55	B1	B0	S61	S62	S63	S64	S65	S66
1	0	1	1	B1	B0	X	S56	S57	S58	S59	S60	B1	B0	S67	S68	S69	S70	S71	S72
1	1	0	0	B1	B0	X	S61	S62	S62	S64	S65	B1	B0	S73	S74	S75	S76	S77	S78
1	1	0	1	B1	B0	X	S66	S67	S68	S69	S70	B1	B0	S79	S80	S81	S82	S83	S84
1	1	1	0	B1	B0	X	S71	S72	S73	S74	S75	B1	B0	S85	S86	S87	S88	S89	S90
1	1	1	1	B1	B0	X	S76	S77	S78	S79	S80	B1	B0	S91	S92	S93	S94	S95	S96

1. B1, B0: Blinking control bit

Control Bit	Blinking Port	
BE B1 B0	5-dot font width	6-dot font width
0 X X	No blink	No blink
1 0 0	No blink	No blink
1 0 1	D4	D5
1 1 X	D4 - D0	D5 - D0

- S1-S80 : Icon pattern ON/OFF in 5-dot font width
S1-S96 : Icon pattern ON/OFF in 6-dot font width
- "X": Don't care.

Figure 9-3 Relationship between SEGRAM and Segment Display

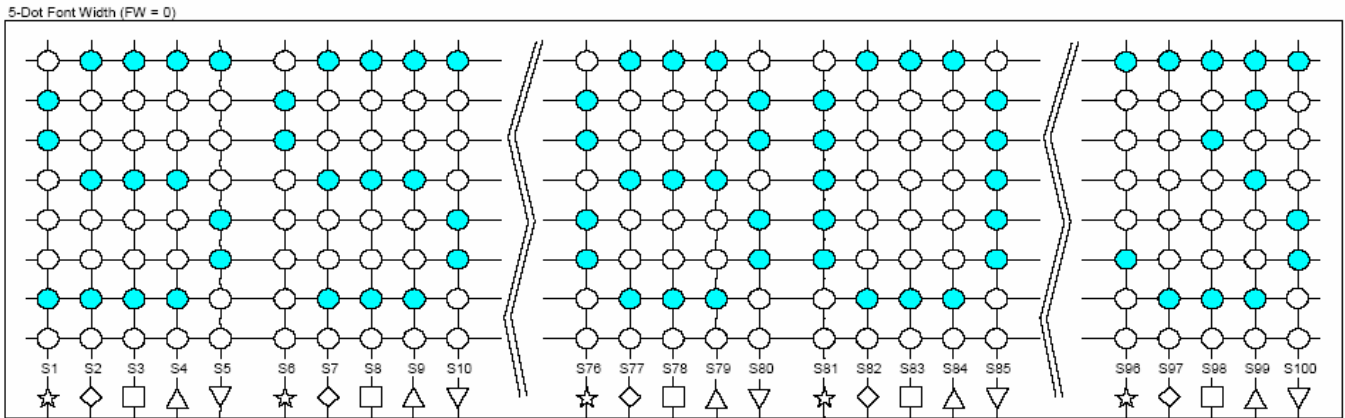

9.10 System Interface

This chip has all four kinds of interface type with MPU: I2C, serial, 4-bit bus and 8-bit bus. I2C, Serial and bus (4-bit/8-bit) is selected by IM1 and IM2 inputs, and 4-bit bus and 8-bit bus is selected by DL bit in the instruction register.

9.10.1 I2C interface

SSD1803A supports I2C interface with a bit rate up to 400 kbits/s. It enables write/ read data or busy flag and supports only the mandatory slave feature showed below.

Slaver address could be set to “011 1100” or “011 1101” by SA0 pin.

The I2C interface send RAM data and executes the commands sent via the I2C Interface. It could send data in to the RAM. The I2C Interface is two-line communication between different ICs or modules. The two lines are a Serial Data line (SDA) and a Serial Clock line (SCL). Both lines must be connected to a positive supply via a pull-up resistor. Data transfer may be initiated only when the bus is not busy. (Note: SDAin and SDAout are short together and forms SDA in SSD1803A)

Bit Transfer

One data bit is transferred during each clock pulse. The data on the SDA line must remain stable during the HIGH period of the clock pulse because changes in the data line at this time will be interpreted as a control signal. Bit transfer is illustrated in Figure 9-4.

Start and Stop conditions

Both data and clock lines remain HIGH when the bus is not busy. A HIGH-to-LOW transition of the data line, while the clock is HIGH is defined as the START condition (S). A LOW-to-HIGH transition of the data line while the clock is HIGH is defined as the STOP condition (P). The START and STOP conditions are illustrated in Figure 9-5.

System Configuration

The system configuration consists of

- Transmitter: the device, which sends the data to the bus
- Master: the device, which initiates a transfer, generates clock signals and terminates a transfer
- Slave: the device addressed by a master
- Multi-Master: more than one master can attempt to control the bus at the same time without corrupting the message
- Arbitration: procedure to ensure that, if more than one master simultaneously tries to control the bus,

only one is allowed to do so and the message is not corrupted

- Synchronization: procedure to synchronize the clock signals of two or more devices.

Acknowledge

Each byte of eight bits is followed by an acknowledge bit. The acknowledge bit is a HIGH signal put on the bus by the transmitter during which time the master generates an extra acknowledge related clock pulse. A slave receiver which is addressed must generate an acknowledge after the reception of each byte. A master receiver must also generate an acknowledge after the reception of each byte that has been clocked out of the slave transmitter. The device that acknowledges must pull-down the SDA line during the acknowledge clock pulse, so that the SDA line is stable LOW during the HIGH period of the acknowledge related clock pulse (set-up and hold times must be taken into consideration). A master receiver must signal an end-of-data to the transmitter by not generating an acknowledge on the last byte that has been clocked out of the slave. In this event the transmitter must leave the data line HIGH to enable the master to generate a STOP condition. Acknowledgement on the I2C Interface is illustrated in Figure 9-6.

Figure 9-4: Bit transfer on the I2C-bus

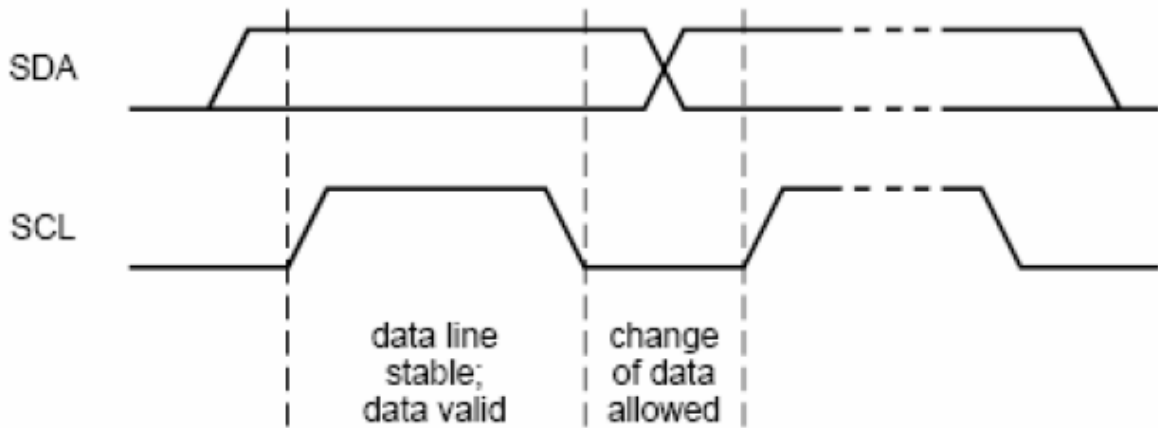

Figure 9-5: START and STOP conditions

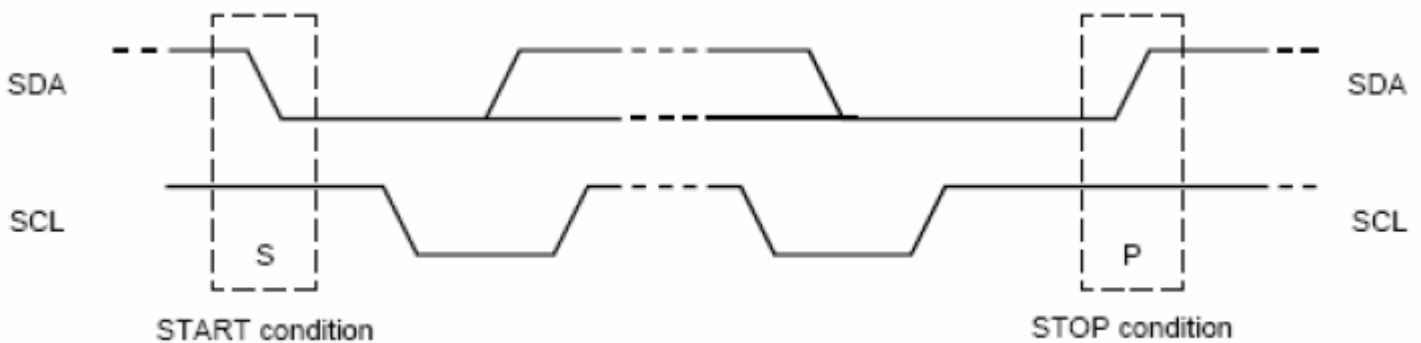
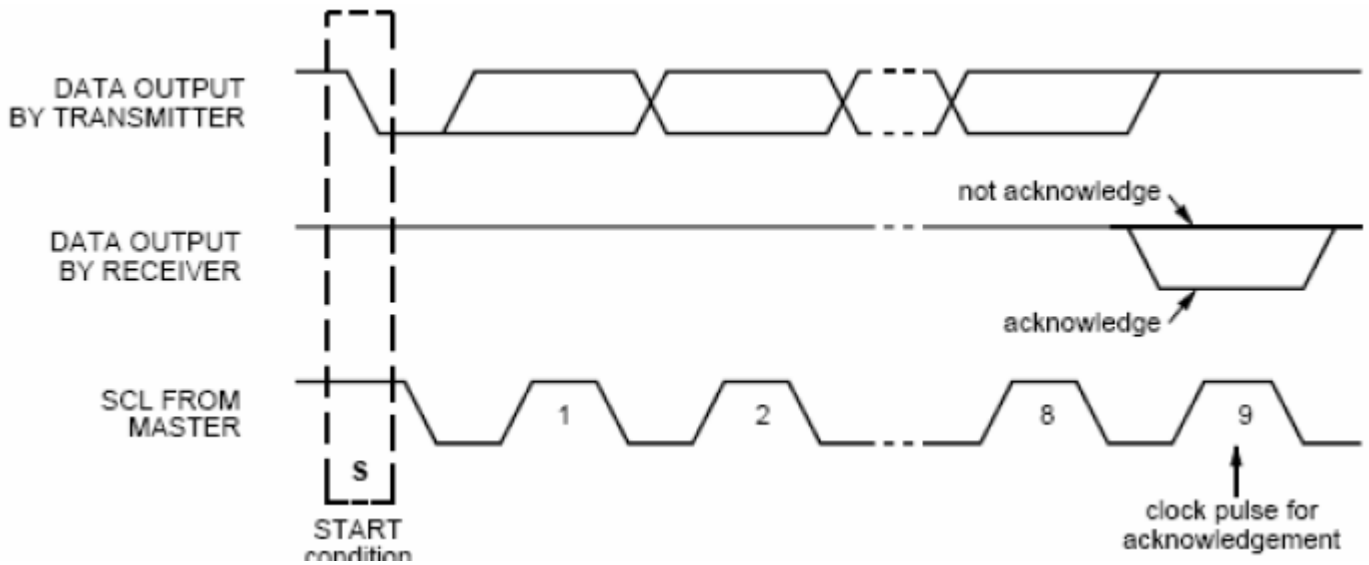

Figure 9-6: Acknowledge on the I2C bus



I2C Interface Protocol

The SSD1803A supports command, data read/ write addressed slaves on the bus. Before any data is transmitted on the I2C Interface, the device, which should respond, is addressed first. Two 7-bit slave addresses (0111100 to 0111101) are reserved for the SSD1803A. The R/W# is assigned to 0 for Write and 1 for Read. The I2C Interface protocol is illustrated in Figure 9-7 to 9-9.

The sequence is initiated with a START condition (S) from the I2C Interface master, which is followed by the slave address. All slaves with the corresponding address acknowledge in parallel, all the others will ignore the I2C Interface transfer. After acknowledgement, one or more command words follow which define the status of the addressed slaves.

A command word consists of control byte, which defines C0 and D/C#, plus a data byte. The last control byte is tagged with a cleared most significant bit (i.e. the continuation bit Co). After the last control byte with a cleared Co bit, only data bytes will follow. The state of the D/C# bit defines whether the data byte is interpreted as a command or as RAM data. All addressed slaves on the bus also acknowledge the control and data bytes. After the last control byte, depending on the D/C# bit setting; either a series of display data bytes or command data bytes may follow. If the D/C# bit is set to logic 1, these display bytes are stored in the display RAM at the address specified by the data pointer. The data pointer is automatically updated and the data is directed to the intended SSD1803A device. If the D/C# bit of the last control byte is set to logic 0, these command bytes will be decoded and the setting of the device will be changed according to the received commands. Only the addressed slave makes the acknowledgement after each byte. At the end of the transmission the I2C INTERFACE-bus master issues a STOP condition (P).

Figure 9-7: I2C write mode

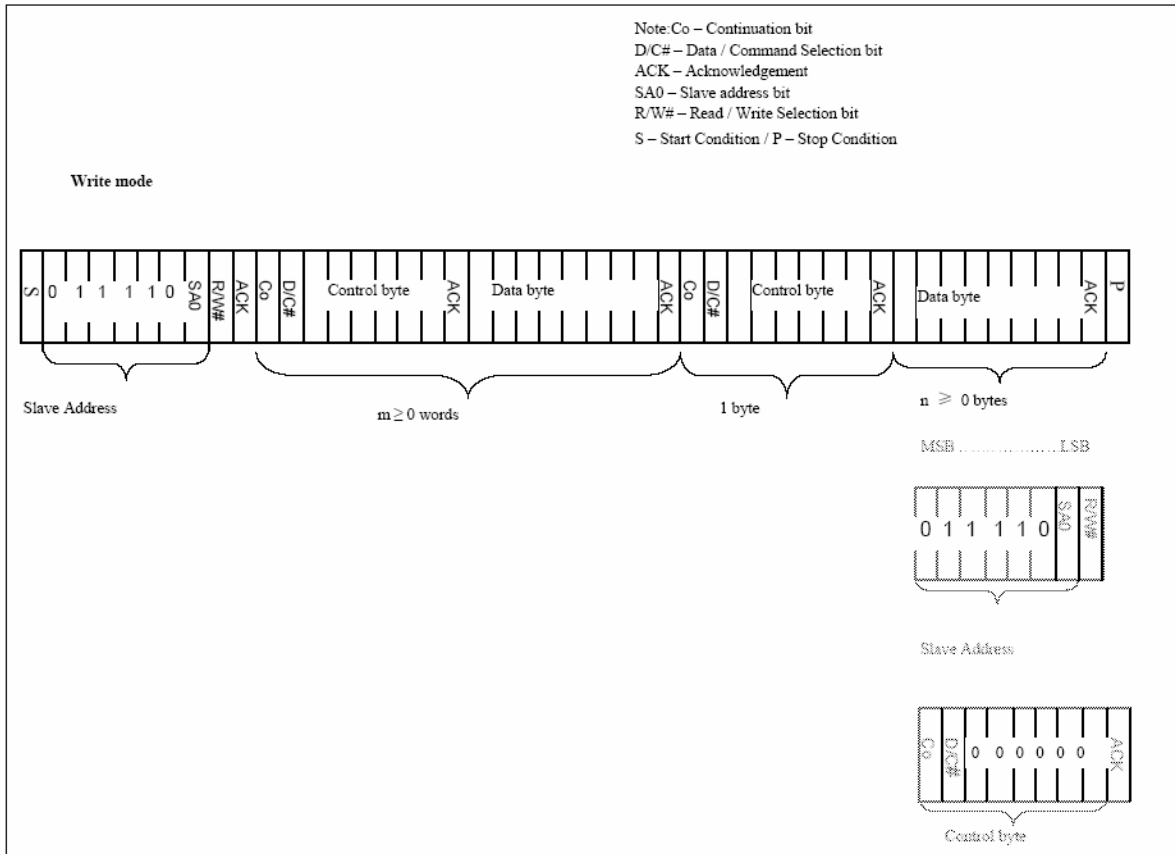
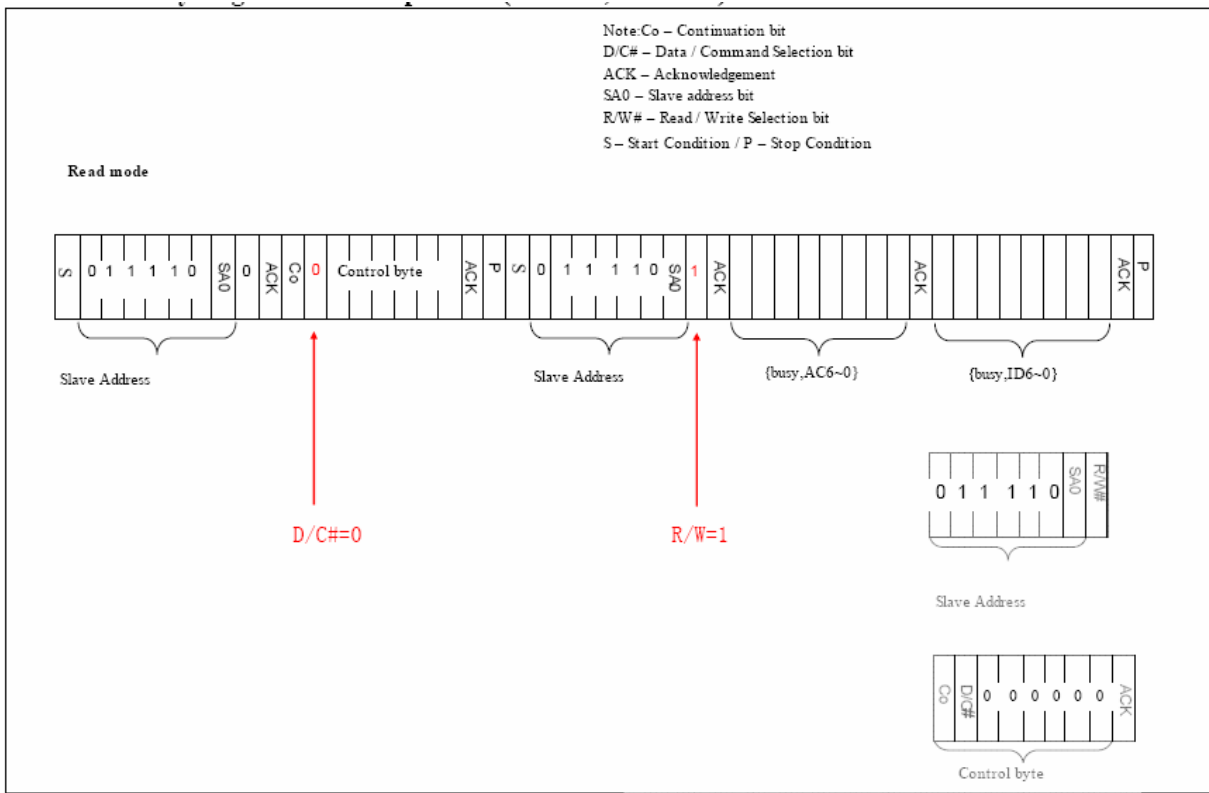

Figure 9-8: I2C read mode
Read busy flag and address/part ID (D/C#=0, R/W#=1)



Read ram (D/C#=1, R/W#=1)

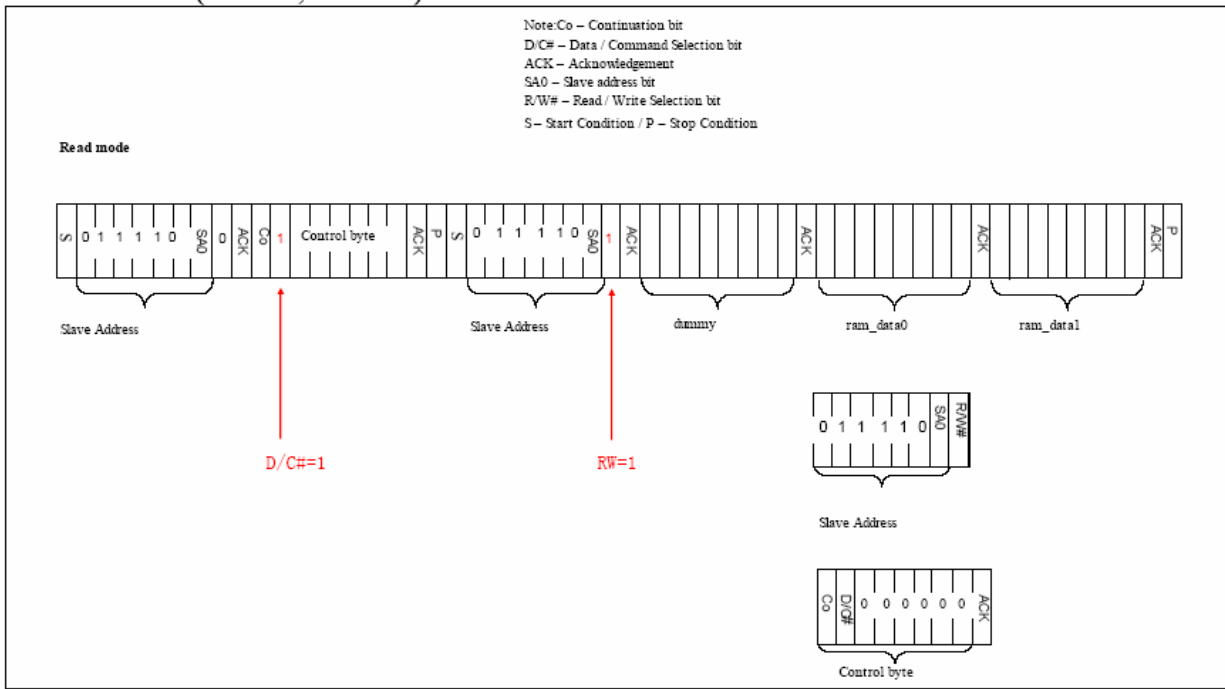
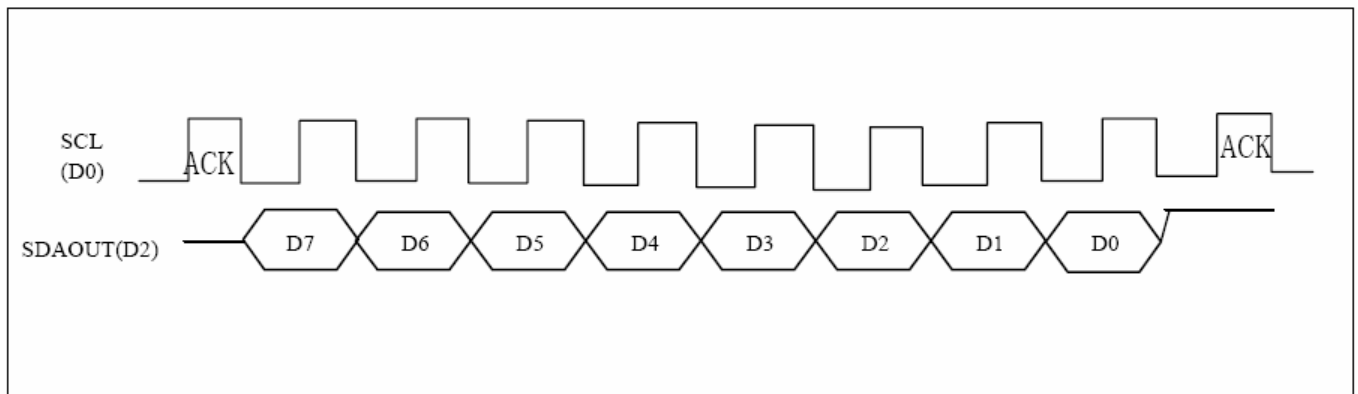

Figure 9-9: Read Timing



During read or write operation, two 8-bit registers are used. One is data register (DR), the other is instruction register (IR). The data register (DR) is used as temporary data storage place for being written into or read from DDRAM/ CGRAM/SEGRAM, target RAM is selected by RAM address setting instruction. Each internal operation, reading from or writing into RAM, is done automatically. So to speak, after MPU reads DR data, the data in the next DDRAM/ CGRAM/ SEGRAM address is transferred into DR automatically. Also after MPU writes data to DR, the data in DR is transferred into DDRAM/ CGRAM/ SEGRAM automatically. The Instruction register (IR) is used only to store instruction code transferred from MPU. MPU cannot use it to read instruction data. To select register, use D/C# I2C mode.

Table 9-5: Bus interface operations according to D/C# and R/W# inputs

D/C#	R/W#	Operation
0	0	Instruction write operation (MPU writes Instruction code into IR)
0	1	Read busy flag (DB7) and address counter (DB0 - DB6)
1	0	Data write operation (MPU writes data into DR)
1	1	Data read operation (MPU reads data from DR/ Part ID)

9.11 5V IO regulator

SSD1803A accepts two power supply range:

2.4-3.6V [**Low Voltage I/O Application**] and

4.5-5.5V [**5V I/O Application**]

5V IO Regulator is enabled to regulate 5V I/O input to 3V for power supply of internal circuit blocks.

Note: In 5V I/O Application, VOUT should not be lower than VDDIO.

Table 9-6 summarizes the input/ output connection of 5V IO regulator in normal application.

Table 9-6: 5V IO regulator pin description

Pin Name	Low Voltage I/O Application	5V I/O Application
VDDREG	Low, disable 5V IO regulator	High, enable 5V IO regulator
VCI	Short to VDD	Short to VDD
VDD	2.4 -3.6V	NC with stabilizing capacitor It outputs 3V
VDDIO	2.4 -VCI	4.5 -5.5V

9.12 LCD Driving Voltage Generator and Regulator

This module generates the LCD voltage required for display driving output.

9.12.1 External VLCD mode

When on-chip booster is turned off, VLCD can be supplied externally to V0 for display driving.

Figure 9-10: On-chip voltage converter application set up

When booster is off and voltage follower is on (Bon=0; Don=1)

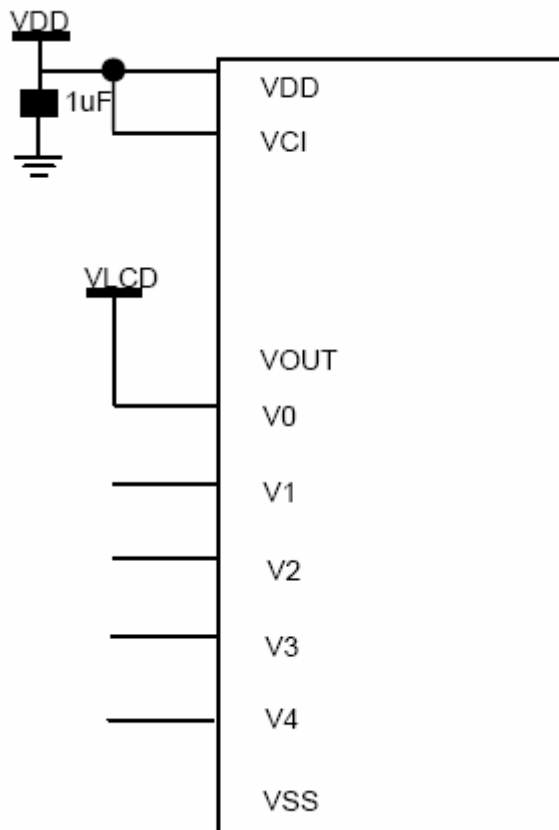
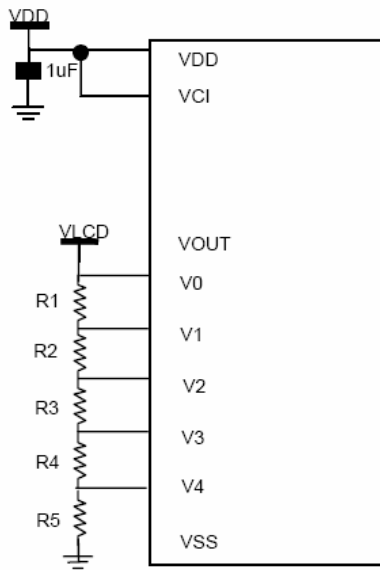

Figure 9-11: On-chip voltage converter application set up
When both booster and voltage follower is off (Bon=0; Don=0)



R1, R2, R3, R4, R5: 20K
VLCD: 10V (max)
*** Recommended values for 1/5 bias application**

9.12.2 Internal voltage mode

a) On-chip DC-DC voltage converter

Voltage converter is available when Bon=1. Figure 9-21 shows the circuits boosting up the electric potential between VDD – VSS toward positive side and boosted voltage is output at VOUT.

Figure 9-12: On-chip voltage converter application set up

When both booster and voltage follower is on (Bon=1; Don=1)

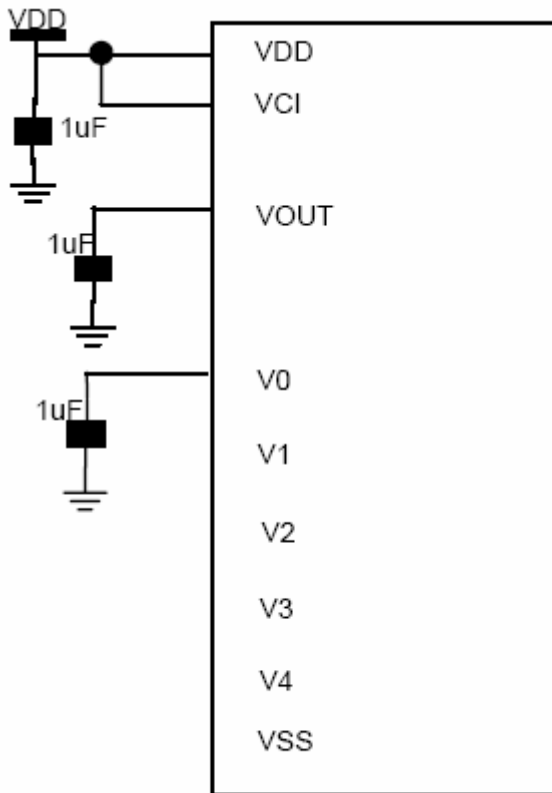
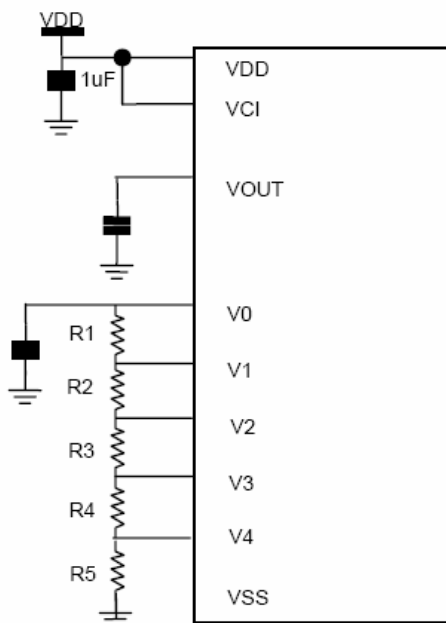

Figure 9-13: On-chip voltage converter application set up

When both booster is on and voltage follower is off (Bon=1; Don=0)



R1, R2, R3, R4, R5: 20K

*** Recommended values for 1/5 bias application**

b) Voltage regulator circuits (Gain) and Contrast Control

There is a voltage regulator circuits to determine liquid crystal operating voltage, V_0 , by adjusting resistors, R_a and R_b , within the range of $|V_4| < |V_0|$. The circuits which are turned on with voltage converter consist of an operational-amplifier circuits and a feedback gain control.

V_{OUT} is the operating voltage for the op-amp, it is required to supply internally or externally. It consists of a feedback gain control for LCD driving contrast curves, eight settings can be selected through software command (Internal resistor ratio $R_{ab2} \sim 0$).

Figure 9-14: Voltage regulator circuit

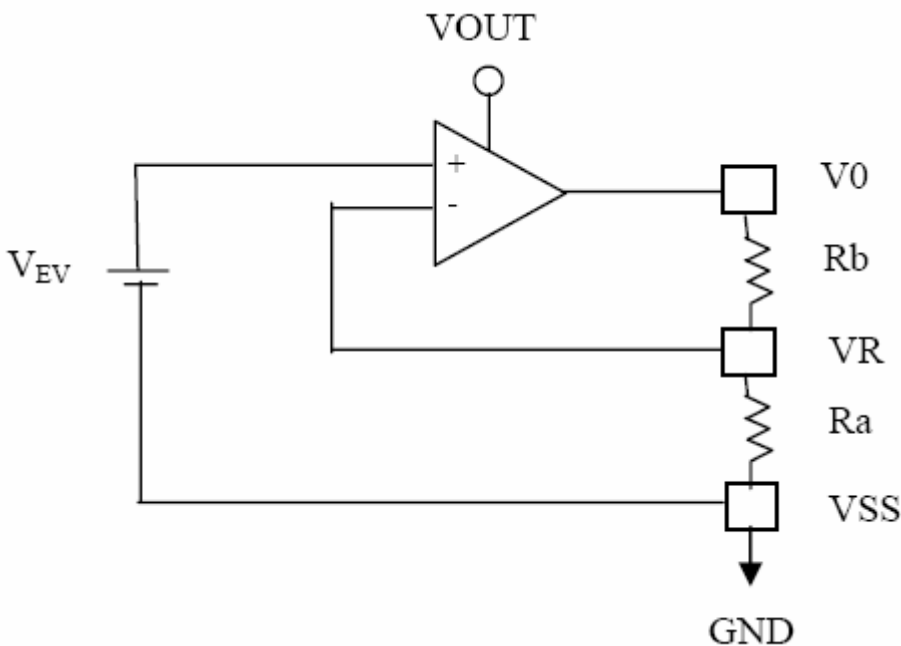

Also, software command (C1-5) is used to adjust the 64 contrast voltage levels at each voltage regulator feedback gain. The equation of calculating the LCD driving voltage is given as:

$$V_0 = \left(1 + \frac{R_b}{R_a}\right) \times V_{EV} [V] \text{ -----(Equation 1)}$$

$$V_{EV} = \left[1 - \frac{(63 - \alpha)}{300}\right] \times V_{REF} [V] \text{ --(Equation 2)}$$

, where $V_{REF} = 2$ and $\alpha = \text{contrast setting}_{(d)}$

Please refer to Figure 9-24 for the contrast curve with 8 sets of internal resistor network gain.

Figure 9-15: Contrast curve

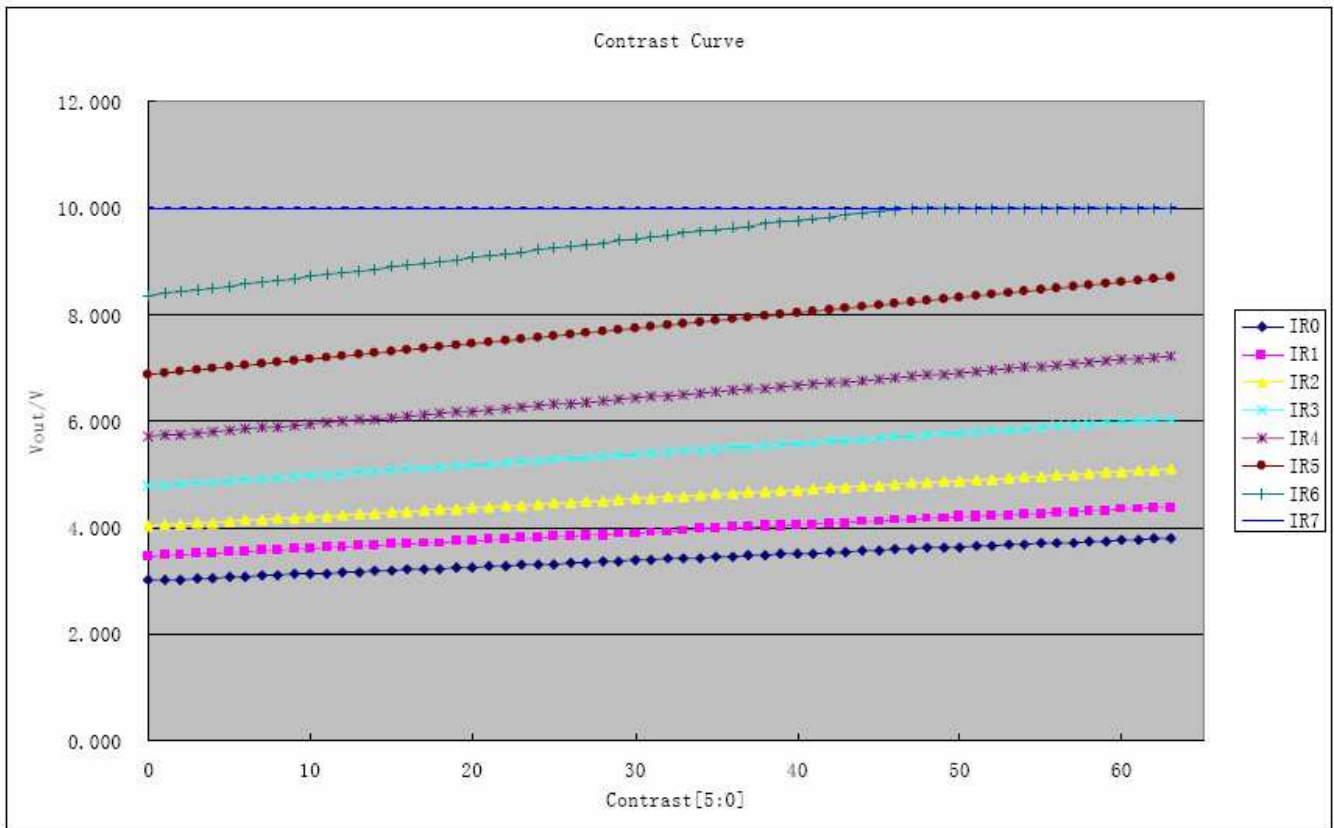

c) Bias Divider

If the Don command is enabled, this circuit block will divide the voltage regulator circuit output (V0) to give the LCD driving levels. External stabilizing capacitors for the divider are optional to reduce the external hardware and pin counts.

d) Bias Ratio Selection circuitry

The software control circuit of 1/4 to 1/7 bias ratio in order to match the characteristic of LCD panel.

e) Self adjust temperature compensation circuitry

Provide 4 different compensation grade selections to satisfy the various liquid crystal temperature grades (-0.05%, -0.10%, -0.15%, -0.20%). The grading can be selected by software control. Defaulted temperature coefficient (TC) value is $-0.05\%/^{\circ}\text{C}$.

7.13 Oscillator Circuit

This module is an On-Chip low power temperature compensation oscillator circuitry. The oscillator generates the clock for the DC-DC voltage converter and the Display Timing Generator. User may choose to use internal oscillator clock or supply external clock by CLS pin.

10. Reliability

Content of Reliability Test (Wide temperature, -20°C~70°C)

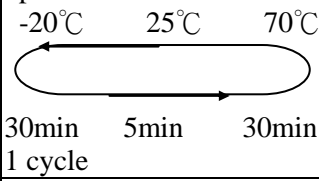
Environmental Test			
Test Item	Content of Test	Test Condition	Note
High Temperature storage	Endurance test applying the high storage temperature for a long time.	80°C 200hrs	2
Low Temperature storage	Endurance test applying the high storage temperature for a long time.	-30°C 200hrs	1,2
High Temperature Operation	Endurance test applying the electric stress (Voltage & Current) and the thermal stress to the element for a long time.	70°C 200hrs	—
Low Temperature Operation	Endurance test applying the electric stress under low temperature for a long time.	-20°C 200hrs	1
High Temperature/ Humidity Operation	The module should be allowed to stand at 60°C, 90%RH max For 96hrs under no-load condition excluding the polarizer, Then taking it out and drying it at normal temperature.	60°C, 90%RH 96hrs	1,2
Thermal shock resistance	The sample should be allowed stand the following 10 cycles of operation  30min 5min 30min 1 cycle	-20°C/70°C 10 cycles	—
Vibration test	Endurance test applying the vibration during transportation and using.	Total fixed amplitude : 1.5mm Vibration Frequency : 10~55Hz One cycle 60 seconds to 3 directions of X, Y, Z for Each 15 minutes	3
Static electricity test	Endurance test applying the electric stress to the terminal.	VS=800V, RS=1.5kΩ CS=100pF 1 time	—

Note1: No dew condensation to be observed.

Note2: The function test shall be conducted after 4 hours storage at the normal Temperature and humidity after remove from the test chamber.

Note3: Vibration test will be conducted to the product itself without putting it in a container.

11. Backlight Information

Specification

PARAMETER	SYMBOL	MIN	TYP	MAX	UNIT	TEST CONDITION
Supply Current	I _{LED}	43.2	48	60	mA	V= 3.5 V
Supply Voltage	V	3.4	3.5	3.6	V	—
Reverse Voltage	V _R	—	—	5	V	—
Luminous Intensity (Without LCD)	I _V	400	500	—	CD/M ²	I _{LED} =48 mA
Chromaticity	x	—	0.30	—	—	—
	y	—	0.29	—	—	—
LED Life Time	—		50K		Hr.	I _{LED} ≤ 48 mA
Color	White					

Note: The LED of B/L is drive by current only ; driving voltage is only for reference
 To make driving current in safety area (waste current between minimum and maximum).

12. Inspection specification

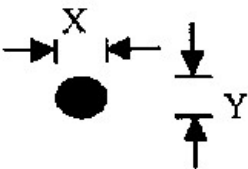
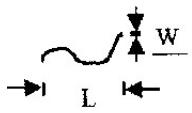
NO	Item	Criterion	AQL												
01	Electrical Testing	1.1 Missing vertical, horizontal segment, segment contrast defect. 1.2 Missing character , dot or icon. 1.3 Display malfunction. 1.4 No function or no display. 1.5 Current consumption exceeds product specifications. 1.6 LCD viewing angle defect. 1.7 Mixed product types. 1.8 Contrast defect.	0.65												
02	Black or white spots on LCD (display only)	2.1 White and black spots on display $\leq 0.25\text{mm}$, no more than three white or black spots present. 2.2 Densely spaced: No more than two spots or lines within 3mm	2.5												
03	LCD black spots, white spots, contamination (non-display)	3.1 Round type : As following drawing $\Phi = (x + y) / 2$  <table border="1" data-bbox="826 1077 1305 1328"> <thead> <tr> <th>SIZE</th> <th>Acceptable Q TY</th> </tr> </thead> <tbody> <tr> <td>$\Phi \leq 0.10$</td> <td>Accept no dense</td> </tr> <tr> <td>$0.10 < \Phi \leq 0.20$</td> <td>2</td> </tr> <tr> <td>$0.20 < \Phi \leq 0.25$</td> <td>1</td> </tr> <tr> <td>$0.25 < \Phi$</td> <td>0</td> </tr> </tbody> </table>	SIZE	Acceptable Q TY	$\Phi \leq 0.10$	Accept no dense	$0.10 < \Phi \leq 0.20$	2	$0.20 < \Phi \leq 0.25$	1	$0.25 < \Phi$	0	2.5		
		SIZE	Acceptable Q TY												
$\Phi \leq 0.10$	Accept no dense														
$0.10 < \Phi \leq 0.20$	2														
$0.20 < \Phi \leq 0.25$	1														
$0.25 < \Phi$	0														
3.2 Line type : (As following drawing)  <table border="1" data-bbox="660 1431 1305 1675"> <thead> <tr> <th>Length</th> <th>Width</th> <th>Acceptable Q TY</th> </tr> </thead> <tbody> <tr> <td>---</td> <td>$W \leq 0.02$</td> <td>Accept no dense</td> </tr> <tr> <td>$L \leq 3.0$</td> <td>$0.02 < W \leq 0.03$</td> <td rowspan="2">2</td> </tr> <tr> <td>$L \leq 2.5$</td> <td>$0.03 < W \leq 0.05$</td> </tr> <tr> <td>---</td> <td>$0.05 < W$</td> <td>As round type</td> </tr> </tbody> </table>	Length	Width	Acceptable Q TY	---	$W \leq 0.02$	Accept no dense	$L \leq 3.0$	$0.02 < W \leq 0.03$	2	$L \leq 2.5$	$0.03 < W \leq 0.05$	---	$0.05 < W$	As round type	2.5
Length	Width	Acceptable Q TY													
---	$W \leq 0.02$	Accept no dense													
$L \leq 3.0$	$0.02 < W \leq 0.03$	2													
$L \leq 2.5$	$0.03 < W \leq 0.05$														
---	$0.05 < W$	As round type													
04	Polarizer bubbles	If bubbles are visible, judge using black spot specifications, not easy to find, must check in specify direction. <table border="1" data-bbox="794 1727 1305 2022"> <thead> <tr> <th>Size Φ</th> <th>Acceptable Q TY</th> </tr> </thead> <tbody> <tr> <td>$\Phi \leq 0.20$</td> <td>Accept no dense</td> </tr> <tr> <td>$0.20 < \Phi \leq 0.50$</td> <td>3</td> </tr> <tr> <td>$0.50 < \Phi \leq 1.00$</td> <td>2</td> </tr> <tr> <td>$1.00 < \Phi$</td> <td>0</td> </tr> <tr> <td>Total Q TY</td> <td>3</td> </tr> </tbody> </table>	Size Φ	Acceptable Q TY	$\Phi \leq 0.20$	Accept no dense	$0.20 < \Phi \leq 0.50$	3	$0.50 < \Phi \leq 1.00$	2	$1.00 < \Phi$	0	Total Q TY	3	2.5
Size Φ	Acceptable Q TY														
$\Phi \leq 0.20$	Accept no dense														
$0.20 < \Phi \leq 0.50$	3														
$0.50 < \Phi \leq 1.00$	2														
$1.00 < \Phi$	0														
Total Q TY	3														

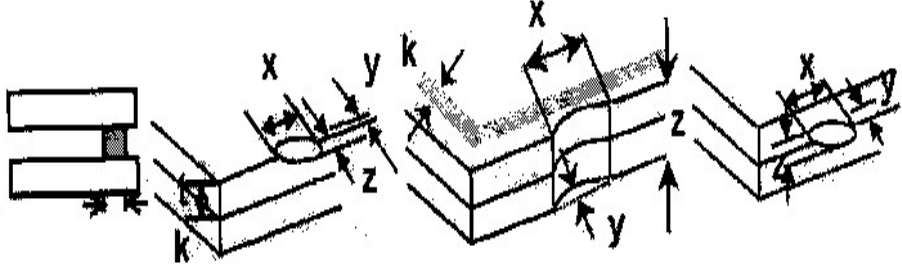
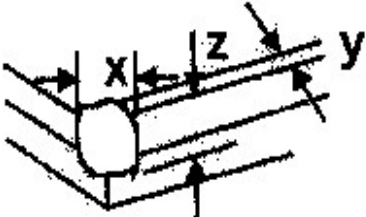
NO	Item	Criterion	AQL																		
05	Scratches	Follow NO.3 LCD black spots, white spots, contamination																			
06	Chipped glass	<p>Symbols Define: x: Chip length y: Chip width z: Chip thickness k: Seal width t: Glass thickness a: LCD side length L: Electrode pad length:</p> <p>6.1 General glass chip : 6.1.1 Chip on panel surface and crack between panels:</p>  <table border="1" data-bbox="395 925 1300 1086"> <tr> <td>z: Chip thickness</td> <td>y: Chip width</td> <td>x: Chip length</td> </tr> <tr> <td>$Z \leq 1/2t$</td> <td>Not over viewing area</td> <td>$x \leq 1/8a$</td> </tr> <tr> <td>$1/2t < z \leq 2t$</td> <td>Not exceed 1/3k</td> <td>$x \leq 1/8a$</td> </tr> </table> <p>⊙If there are 2 or more chips, x is total length of each chip.</p> <p>6.1.2 Corner crack:</p>  <table border="1" data-bbox="395 1473 1300 1635"> <tr> <td>z: Chip thickness</td> <td>y: Chip width</td> <td>x: Chip length</td> </tr> <tr> <td>$Z \leq 1/2t$</td> <td>Not over viewing area</td> <td>$x \leq 1/8a$</td> </tr> <tr> <td>$1/2t < z \leq 2t$</td> <td>Not exceed 1/3k</td> <td>$x \leq 1/8a$</td> </tr> </table> <p>⊙If there are 2 or more chips, x is the total length of each chip.</p>	z: Chip thickness	y: Chip width	x: Chip length	$Z \leq 1/2t$	Not over viewing area	$x \leq 1/8a$	$1/2t < z \leq 2t$	Not exceed 1/3k	$x \leq 1/8a$	z: Chip thickness	y: Chip width	x: Chip length	$Z \leq 1/2t$	Not over viewing area	$x \leq 1/8a$	$1/2t < z \leq 2t$	Not exceed 1/3k	$x \leq 1/8a$	2.5
z: Chip thickness	y: Chip width	x: Chip length																			
$Z \leq 1/2t$	Not over viewing area	$x \leq 1/8a$																			
$1/2t < z \leq 2t$	Not exceed 1/3k	$x \leq 1/8a$																			
z: Chip thickness	y: Chip width	x: Chip length																			
$Z \leq 1/2t$	Not over viewing area	$x \leq 1/8a$																			
$1/2t < z \leq 2t$	Not exceed 1/3k	$x \leq 1/8a$																			

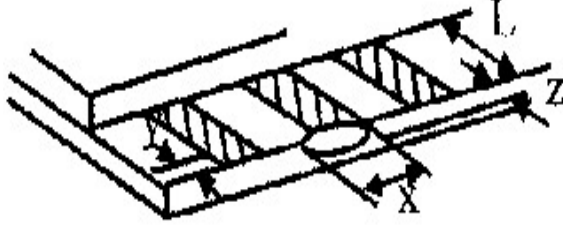
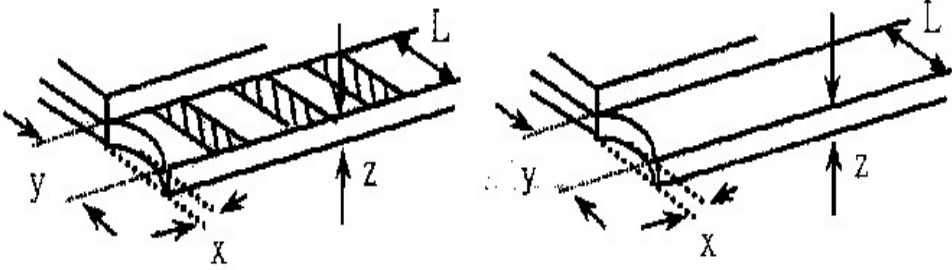
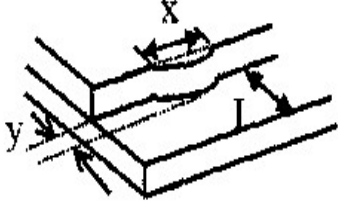
NO	Item	Criterion	AQL																
06	Glass crack	<p>Symbols :</p> <p>x: Chip length y: Chip width z: Chip thickness k: Seal width t: Glass thickness a: LCD side length L: Electrode pad length</p> <p>6.2 Protrusion over terminal :</p> <p>6.2.1 Chip on electrode pad :</p>  <table border="1" data-bbox="304 674 1219 801"> <thead> <tr> <th>y: Chip width</th> <th>x: Chip length</th> <th>z: Chip thickness</th> </tr> </thead> <tbody> <tr> <td>$y \leq 0.5\text{mm}$</td> <td>$x \leq 1/8a$</td> <td>$0 < z \leq t$</td> </tr> </tbody> </table> <p>6.2.2 Non-conductive portion:</p>  <table border="1" data-bbox="376 1128 1219 1256"> <thead> <tr> <th>y: Chip width</th> <th>x: Chip length</th> <th>z: Chip thickness</th> </tr> </thead> <tbody> <tr> <td>$y \leq L$</td> <td>$x \leq 1/8a$</td> <td>$0 < z \leq t$</td> </tr> </tbody> </table> <ul style="list-style-type: none"> ⊙ If the chipped area touches the ITO terminal, over 2/3 of the ITO must remain and be inspected according to electrode terminal specifications. ⊙ If the product will be heat sealed by the customer, the alignment mark not be damaged. <p>6.2.3 Substrate protuberance and internal crack.</p>  <table border="1" data-bbox="715 1496 1224 1630"> <thead> <tr> <th>y: width</th> <th>x: length</th> </tr> </thead> <tbody> <tr> <td>$y \leq 1/3L$</td> <td>$x \leq a$</td> </tr> </tbody> </table>	y: Chip width	x: Chip length	z: Chip thickness	$y \leq 0.5\text{mm}$	$x \leq 1/8a$	$0 < z \leq t$	y: Chip width	x: Chip length	z: Chip thickness	$y \leq L$	$x \leq 1/8a$	$0 < z \leq t$	y: width	x: length	$y \leq 1/3L$	$x \leq a$	2.5
y: Chip width	x: Chip length	z: Chip thickness																	
$y \leq 0.5\text{mm}$	$x \leq 1/8a$	$0 < z \leq t$																	
y: Chip width	x: Chip length	z: Chip thickness																	
$y \leq L$	$x \leq 1/8a$	$0 < z \leq t$																	
y: width	x: length																		
$y \leq 1/3L$	$x \leq a$																		

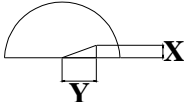
NO	Item	Criterion	AQL
07	Cracked glass	The LCD with extensive crack is not acceptable.	2.5
08	Backlight elements	8.1 Illumination source flickers when lit. 8.2 Spots or scratched that appear when lit must be judged. Using LCD spot, lines and contamination standards. 8.3 Backlight doesn't light or color wrong.	0.65 2.5 0.65
09	Bezel	9.1 Bezel may not have rust, be deformed or have fingerprints, stains or other contamination. 9.2 Bezel must comply with job specifications.	2.5 0.65
10	PCB 、 COB	10.1 COB seal may not have pinholes larger than 0.2mm or contamination. 10.2 COB seal surface may not have pinholes through to the IC. 10.3 The height of the COB should not exceed the height indicated in the assembly diagram. 10.4 There may not be more than 2mm of sealant outside the seal area on the PCB. And there should be no more than three places. 10.5 No oxidation or contamination PCB terminals. 10.6 Parts on PCB must be the same as on the production characteristic chart. There should be no wrong parts, missing parts or excess parts. 10.7 The jumper on the PCB should conform to the product characteristic chart. 10.8 If solder gets on bezel tab pads, LED pad, zebra pad or screw hold pad, make sure it is smoothed down. 10.9 The Scraping testing standard for Copper Coating of PCB  $X * Y \leq 2\text{mm}^2$	2.5 2.5 0.65 2.5 2.5 0.65 2.5 2.5
11	Soldering	11.1 No un-melted solder paste may be present on the PCB. 11.2 No cold solder joints, missing solder connections, oxidation or icicle. 11.3 No residue or solder balls on PCB. 11.4 No short circuits in components on PCB.	2.5 2.5 2.5 0.65

NO	Item	Criterion	AQL
12	General appearance	12.1 No oxidation, contamination, curves or, bends on interface Pin (OLB) of TCP.	2.5
		12.2 No cracks on interface pin (OLB) of TCP.	0.65
		12.3 No contamination, solder residue or solder balls on product.	2.5
		12.4 The IC on the TCP may not be damaged, circuits.	2.5
		12.5 The uppermost edge of the protective strip on the interface pin must be present or look as if it cause the interface pin to sever.	2.5
		12.6 The residual rosin or tin oil of soldering (component or chip component) is not burned into brown or black color.	2.5
		12.7 Sealant on top of the ITO circuit has not hardened.	0.65
		12.8 Pin type must match type in specification sheet.	0.65
		12.9 LCD pin loose or missing pins.	0.65
		12.10 Product packaging must the same as specified on packaging specification sheet.	0.65
		12.11 Product dimension and structure must conform to product specification sheet.	

13. Material List of Components for RoHs

1. WINSTAR Display Co., Ltd hereby declares that all of or part of products (with the mark “#”in code), including, but not limited to, the LCM, accessories or packages, manufactured and/or delivered to your company (including your subsidiaries and affiliated company) directly or indirectly by our company (including our subsidiaries or affiliated companies) do not intentionally contain any of the substances listed in all applicable EU directives and regulations, including the following substances.

Exhibit A : The Harmful Material List

Material	(Cd)	(Pb)	(Hg)	(Cr6+)	PBBs	PBDEs
Limited Value	100 ppm	1000 ppm	1000 ppm	1000 ppm	1000 ppm	1000 ppm
Above limited value is set up according to RoHS.						

2.Process for RoHS requirement :

(1) Use the Sn/Ag/Cu soldering surface ; the surface of Pb-free solder is rougher than we used before.

(2) Heat-resistance temp. :

Reflow : 250°C,30 seconds Max. ;

Connector soldering wave or hand soldering : 320°C, 10 seconds max.

(3) Temp. curve of reflow, max. Temp. : 235±5°C ;

Recommended customer’s soldering temp. of connector : 280°C, 3 seconds.

14. Recommendable storage

1. Place the panel or module in the temperature 25°C±5°C and the humidity below 65% RH
2. Do not place the module near organics solvents or corrosive gases.
3. Do not crush, shake, or jolt the module



Module Number : _____

Page: 1

1、Panel Specification :

- 1. Panel Type : Pass NG , _____
- 2. View Direction : Pass NG , _____
- 3. Numbers of Dots : Pass NG , _____
- 4. View Area : Pass NG , _____
- 5. Active Area : Pass NG , _____
- 6. Operating Temperature : Pass NG , _____
- 7. Storage Temperature : Pass NG , _____
- 8. Others : _____

2、Mechanical Specification :

- 1. PCB Size : Pass NG , _____
- 2. Frame Size : Pass NG , _____
- 3. Material of Frame : Pass NG , _____
- 4. Connector Position : Pass NG , _____
- 5. Fix Hole Position : Pass NG , _____
- 6. Backlight Position : Pass NG , _____
- 7. Thickness of PCB : Pass NG , _____
- 8. Height of Frame to PCB : Pass NG , _____
- 9. Height of Module : Pass NG , _____
- 10. Others : Pass NG , _____

3、Relative Hole Size :

- 1. Pitch of Connector : Pass NG , _____
- 2. Hole size of Connector : Pass NG , _____
- 3. Mounting Hole size : Pass NG , _____
- 4. Mounting Hole Type : Pass NG , _____
- 5. Others : Pass NG , _____

4、Backlight Specification :

- 1. B/L Type : Pass NG , _____
- 2. B/L Color : Pass NG , _____
- 3. B/L Driving Voltage (Reference for LED Type) : Pass NG , _____
- 4. B/L Driving Current : Pass NG , _____
- 5. Brightness of B/L : Pass NG , _____
- 6. B/L Solder Method : Pass NG , _____
- 7. Others : Pass NG , _____

>> **Go to page 2** <<



Module Number : _____

5、Electronic Characteristics of Module :

- 1. Input Voltage : Pass NG , _____
- 2. Supply Current : Pass NG , _____
- 3. Driving Voltage for LCD : Pass NG , _____
- 4. Contrast for LCD : Pass NG , _____
- 5. B/L Driving Method : Pass NG , _____
- 6. Negative Voltage Output : Pass NG , _____
- 7. Interface Function : Pass NG , _____
- 8. LCD Uniformity : Pass NG , _____
- 9. ESD test : Pass NG , _____
- 10. Others : Pass NG , _____

6、Summary :

Sales signature : _____

Customer Signature : _____

Date : / /