



18.5” Wide WXGA High brightness color TFT-LCD module

Model: CH185CLIL-HB2

Date: Jul. 13th, 2012

**Note: This specification is subject to change
without notice**

Customer : _____

Date : _____

Approved

Prepared

Date:

Date:

Contents

- 1. Handling Precautions**
- 2. General Description**
- 3. Functional Block Diagram**
- 4. Absolute Maximum Ratings**
 - 4.1 Absolute Ratings of TFT LCD Module
 - 4.2 Absolute Ratings of Backlight Unit
 - 4.3 Absolute Ratings of Environment
- 5. Electrical characteristics**
 - 5.1 TFT LCD Module
 - 5.2 Backlight Unit
- 6. Signal Characteristic**
 - 6.1 Pixel Format Image
 - 6.2 The Input Data Format
 - 6.4 Interface Timing
 - 6.5 Power ON/OFF Sequence
- 7. Connector & Pin Assignment**
 - 7.1 TFT LCD Module
 - 7.2 Backlight Unit
- 8. Reliability Test**
- 9. Shipping Label**
- 10. Mechanical Characteristic**

RECORD OF REVISION

Version and Date	Page	Old description	New description	Remark
0.1 2012/7/13	All	First Edition for customer		

1. HANDLING PRECAUTIONS

- 1) Since front polarizer is easily damaged, pay attention not to scratch it.
- 2) Be sure to turn off power supply when inserting or disconnecting from input connector.
- 3) Wipe off water drop immediately. Long contact with water may cause discoloration or spots.
- 4) When the panel surface is soiled, wipe it with absorbent cotton or other soft cloth.
- 5) Since the panel is made of glass, it may break or crack if dropped or bumped on hard surface.
- 6) Since CMOS LSI is used in this module, take care of static electricity and insure human earth when handling.
- 7) Do not open or modify the Module Assembly.
- 8) Do not press the reflector sheet at the back of the module to any directions.
- 9) At the insertion or removal of the Signal Interface Connector, be sure not to rotate nor tilt the Interface Connector of the TFT Module.
- 10) After installation of the TFT Module into an enclosure, do not twist nor bend the TFT Module even momentary. At designing the enclosure, it should be taken into consideration that no bending/twisting forces are applied to the TFT Module from outside. Otherwise the TFT Module may be damaged.

2. General Description

2.1, Overview

This specification applies to the 18.5 inch color TFT-LCD module with brightness enhanced backlight and 1-ch LVDS interface.

This module supports the WXGA -1366(H) x 768(V) screen format and 16.7M colors (RGB 6-bits+Hi-FRC data).

2.2 Features

- Sunlight readable display, 1200nits.
- LED backlight
- WXGA (1366x768 pixels) resolution
- RoHS Compliance

2.3 Application

Industrial Application; especial kiosk and digital signage display.

2.4 Display Specifications

Items	Unit	Specification
Screen Diagonal	mm	470.1 (18.51")
Active Area	mm	409.8(H) x 230.4(V)
Pixels H x V	pixels	1366(x3) x 768
Pixels Pitch	um	300 (per one triad) x 300
Pixel Arrangement		RGB Vertical stripe
Display mode		TN mode, normally white
White luminance (center)	Cd/m ²	1200 (Typ.)
Contrast ratio		1,000 (Typ.)
Optical Response Time	msec	5 ms (Typ. on/off)
Normal Input Voltage VDD	Volt	5
Power Consumption (VDD Line + LED Lines)	Watt	27.5 (max)
Weight	Grams	TBD
Physical size	mm	430.37(W) x 254.6(H) (Typ) x 11.6(D) (Max)
Electrical Interface		One Chanel LVDS
Support Colors		16.7 M colors (RGB 6-bits + Hi_FRC)
Surface Treatment		Anti-Glare, 3H
Temperature range		
Operating	°C	-20 ~ 50
Storage (Shipping)	°C	-20 ~ 60
RoHS Compliance		RoHS Compliance

2.5 Optical Characteristics

The following optical characteristics are measured under stable condition at 25 °C

Items	Unit	Conditions	Min.	Typ.	Max.	Note
Viewing angle	Deg.	Horizontal (Right) CR=10 (Left)	150	170		2
		Vertical (Up) CR=10 (Down)	140	160		
Contrast Ratio		Normal Direction	600	1000		3
Response Time	msec	Raising time (T_{rR})		3.8	5.5	4
		Falling time (T_{rF})		1.2	2.5	
		Raising + Falling		5	8	
Color / Chromaticity Coordinates (CIE)		Red x	-0.03	0.648	+0.03	5
		Red y		0.339		
		Green x		0.292		
		Green y		0.603		
		Blue x		0.143		
		Blue y		0.070		
Color coordinates (CIE) White		White x		0.313		
		White y		0.329		
Center Luminance	Cd/m ²		1000	1200		6
Luminance Uniformity	%		70	75		7
Crosstalk (in 60 Hz)	%				1.5	
Flicker	dB				-20	

Note 1: Measurement method

The LCD module should be stabilized at given temperature for 0.5 hour to avoid abrupt temperature change during measuring. In order to stabilize the luminance, the measurement should be executed after lighting Backlight for 1 hour in a windless room.

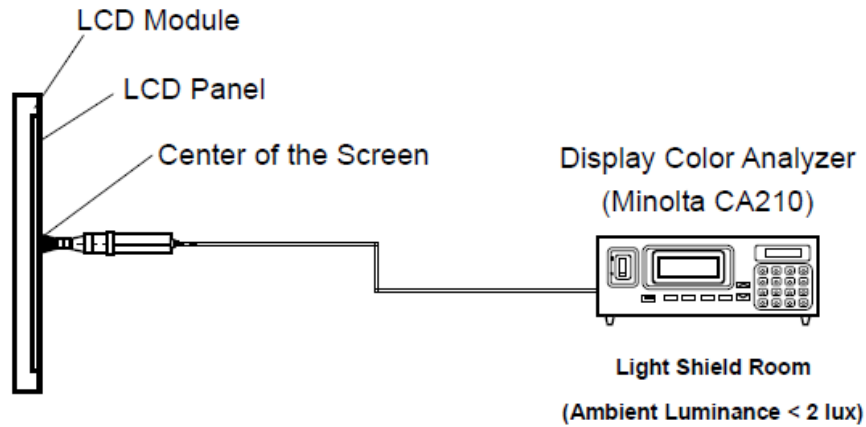

Note 2: Definition of viewing angle

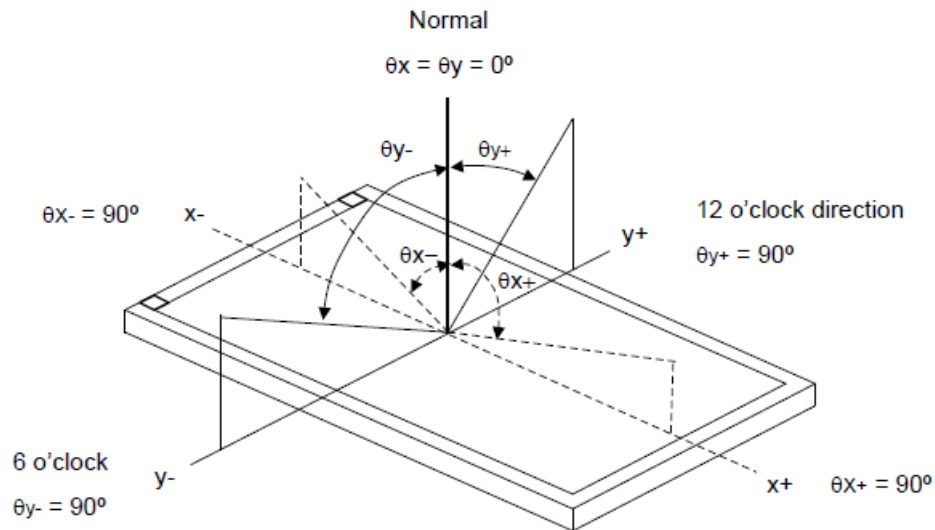

Note 3: Contrast ratio is measured by Mintta BM-7

Note 4: Definition of Response time

The output signals of photo detector are measured when the input signals are changed from “Full Black” to “Full White” (rising time), and from “Full White” to “Full Black” (falling time), respectively. The response time is interval between the 10% and 90% of amplitudes. Please refer to the figure as below.

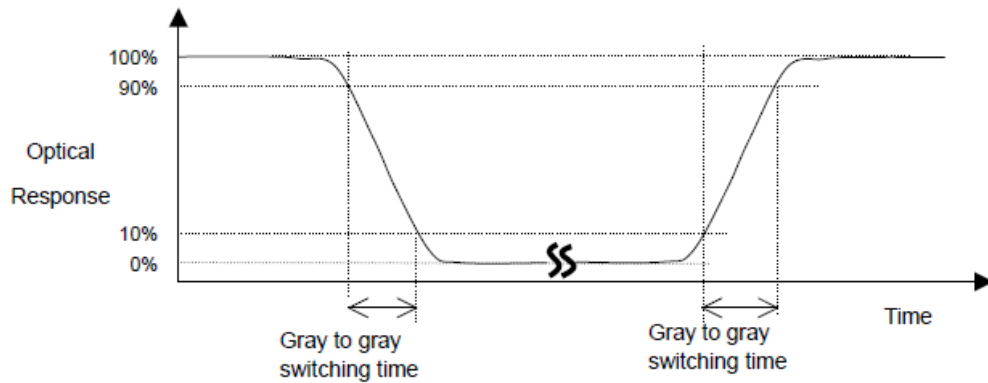

Note 5: Color chromaticity and coordinates (CIE) is measured by Minta BM-7

Note 6: Center luminance is measured by Minta BM-7

Note 7: Luminance uniformity of these 5 points is defined as below and measured by Minta BM-7

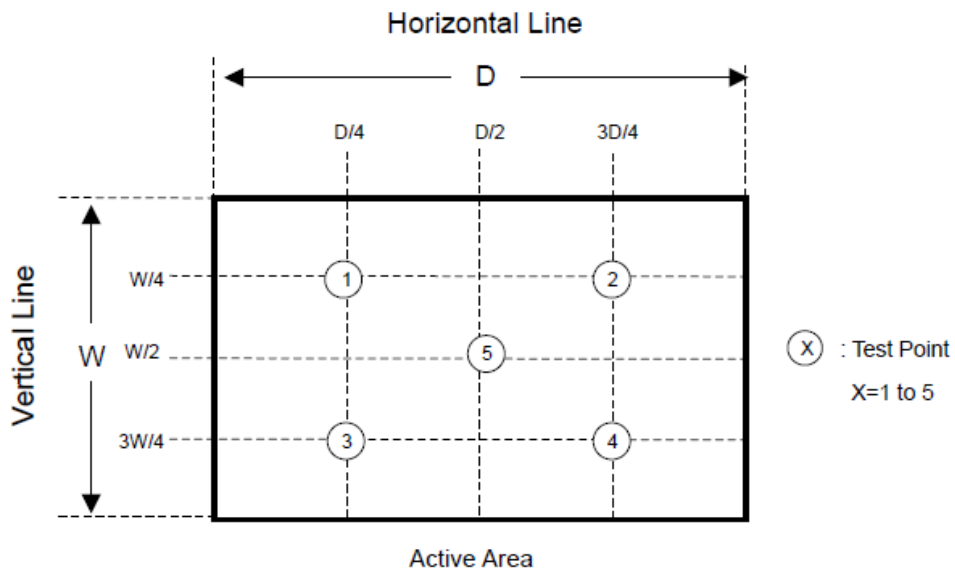

$$\text{Uniformity} = (\text{Min. Luminance of 5 points}) / (\text{Max. Luminance of 5 points})$$

3. Functional Block Diagram

The following diagram shows the functional block of the 18.5 inches Color TFT-LCD Module:

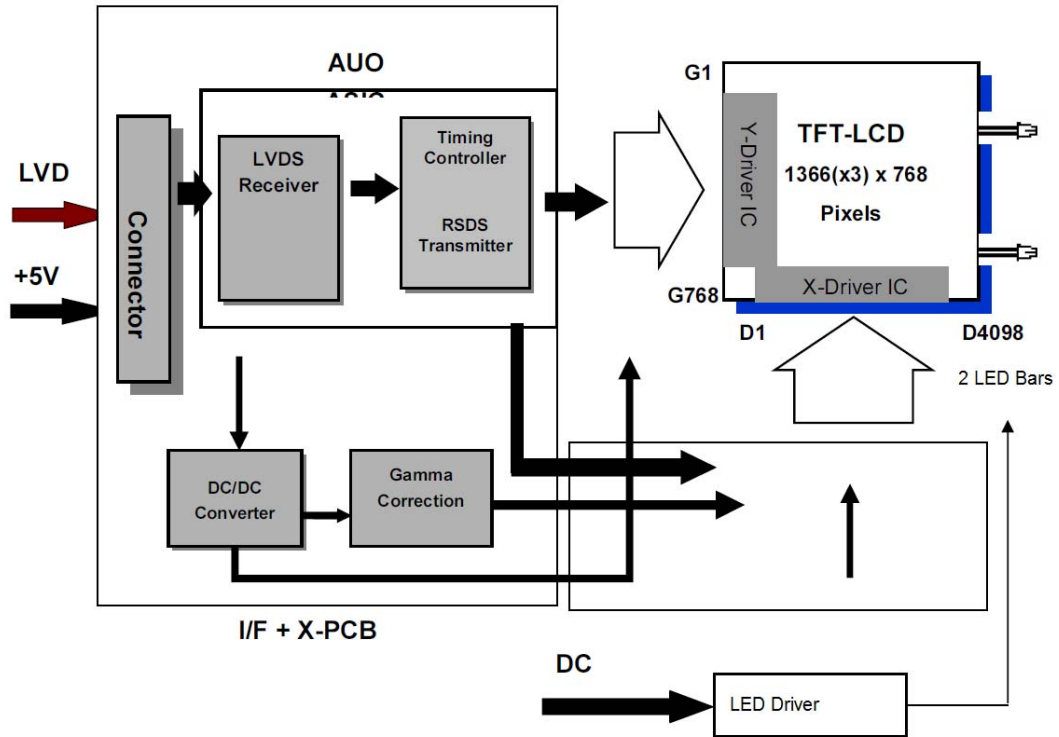

I/F PCB Interface:

FI-XB30SSRL-HF16(JAE)/MSCKT2407P30HB(信盛)

Mating Type:

FI-X30HL (JAE)(Locked Type)

4. Absolute Maximum Ratings

Absolute maximum ratings of the module are as following:

4.1 TFT LCD Module

Items	Symbol	Min	Max	Unit	Conditions
Logic/ LCD drive voltage	VDD	4.5	5.5	Volt	Note 1, 2

4.2 Backlight unit

Items	Symbol	Min	Max	Unit	Conditions
LED Current	I LED		560	mA	Note 1, 2

4.3 Absolute Ratings of Environment

Items	Symbol	Values			Unit	Conditions
		Min.	Typ.	Max.		
Operation temperature	T _{OP}	-20	-	50	°C	Note 3
Operation Humidity	H _{OP}	5		90	%	
Storage temperature	T _{ST}	-20		60	°C	
Storage Humidity	H _{ST}	5		90	%	

Note 1: With in Ta= 25°C

Note 2: Permanent damage to the device may occur if exceed maximum values

Note 3: For quality performance, please refer to IIS (Incoming Inspection Standard).

Note 4: Good thermal conduction to chassis is necessary at TOP & Button edge of display module.

5. Electrical characteristics

5.1 TFT LCD Module

5.1.1 Power Specification

Input power specifications are as follows

Symbol	Parameter	Min	Typ.	Max	Unit	Conditions
VDD	Logic/ LCD Drive Voltage	4.5	5	5.5	Volt	+/- 10%
IDD	Input current		0.7	0.85	A	VDD=5V, All black pattern. At 75Hz, +30%
PDD	VDD power		3.5	4.25	W	VDD=5V, All black pattern. At 75Hz,
IRush	Inrush current			3	A	Note 1
VDDrp	Allowable Logic/LCD Drive Ripple Voltage			200	mV p-p	VDD=5V, All black pattern. At 75Hz,

Note 1: Measurement conditions:

The duration of rising time of input power is 470 us.

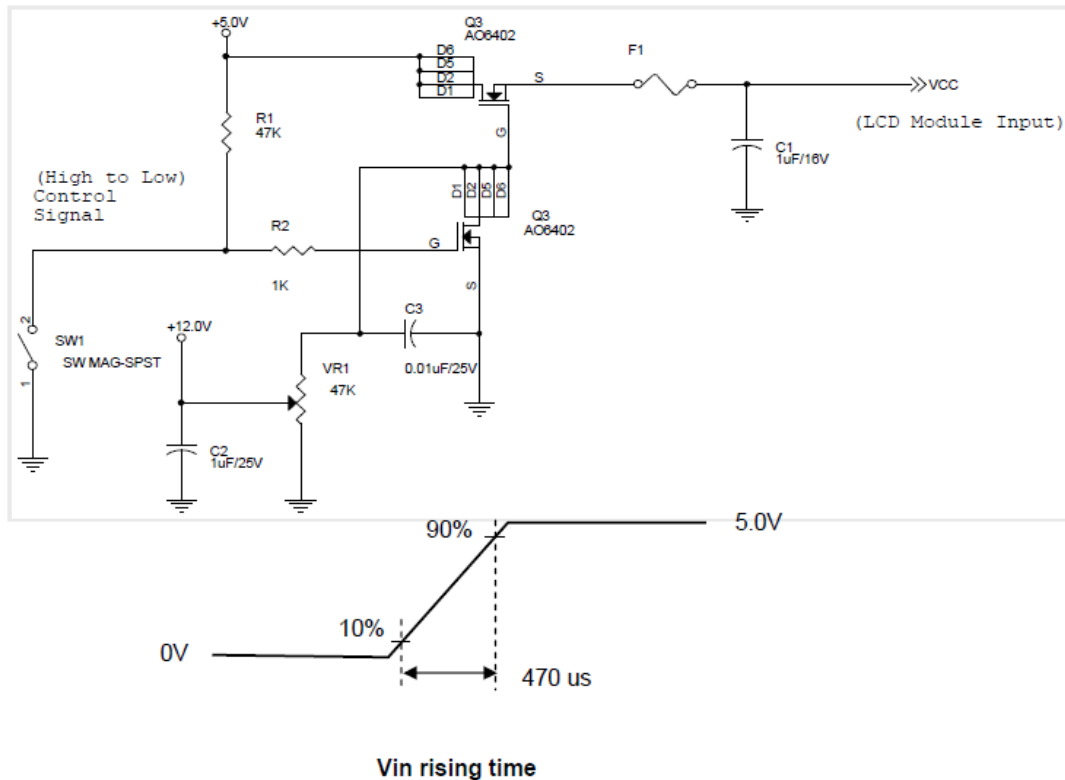

5.1.2 Signal Electrical Characteristics

Input signal shall be low or Hi-Z state when VDD is off. Please refer to specification of SN75LVDS82DGG (Texas Instruments) in detail.

Characteristics of each signal are as following:

Symbol	Parameter	Min	Typ	Max	Unit	Condition
VTH	Differential Input High Threshold	-	+50	+100	mV	VICM = 1.2V
VTL	Differential Input Low Threshold	-100	-50	-	mV	VICM = 1.2V
VID	Input Differential Voltage	100	400	600	mV	
VICM	Differential Input Common Mode Voltage	+1.0	+1.2	+1.4	V	VTH/VTL = 100mV

5.2 Backlight Unit

Parameter guideline is under stable conditions at 25°C (Room Temperature):

Parameter	Min	Typ	Max	Unit	Note
LED voltage (VL)		29.7		[V]	2
LED current (IL)		360		[mA]	2,
LED Life Time(LTLED)		40,000		[Hour]	1

Note 1: The “LED lift time” is defined as the module brightness decrease to 50% original brightness that the ambient temperature is 25°C and typical LED Current at 360mA .

Note 2: The LED driving condition is defined for each LED module.(9 LED Serial, a LED includes 7 Chips)

Note 3: The variance of LED Light Bar power consumption is ±10%. Calculator value for reference ($IL \times VL \times 2 = PLED$)

6. Signal Characteristic

6.1 Pixel Format Image

Following figure shows the relationship of the input signals and LCD pixel format.

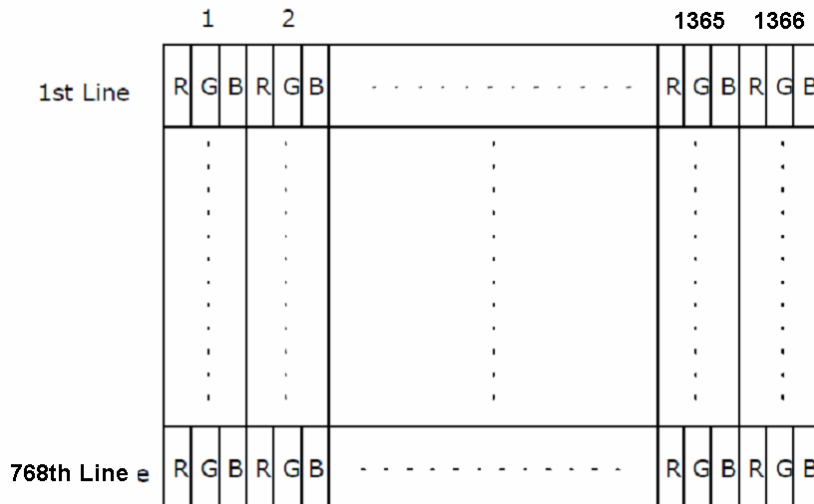

6.2 The Input Data Format

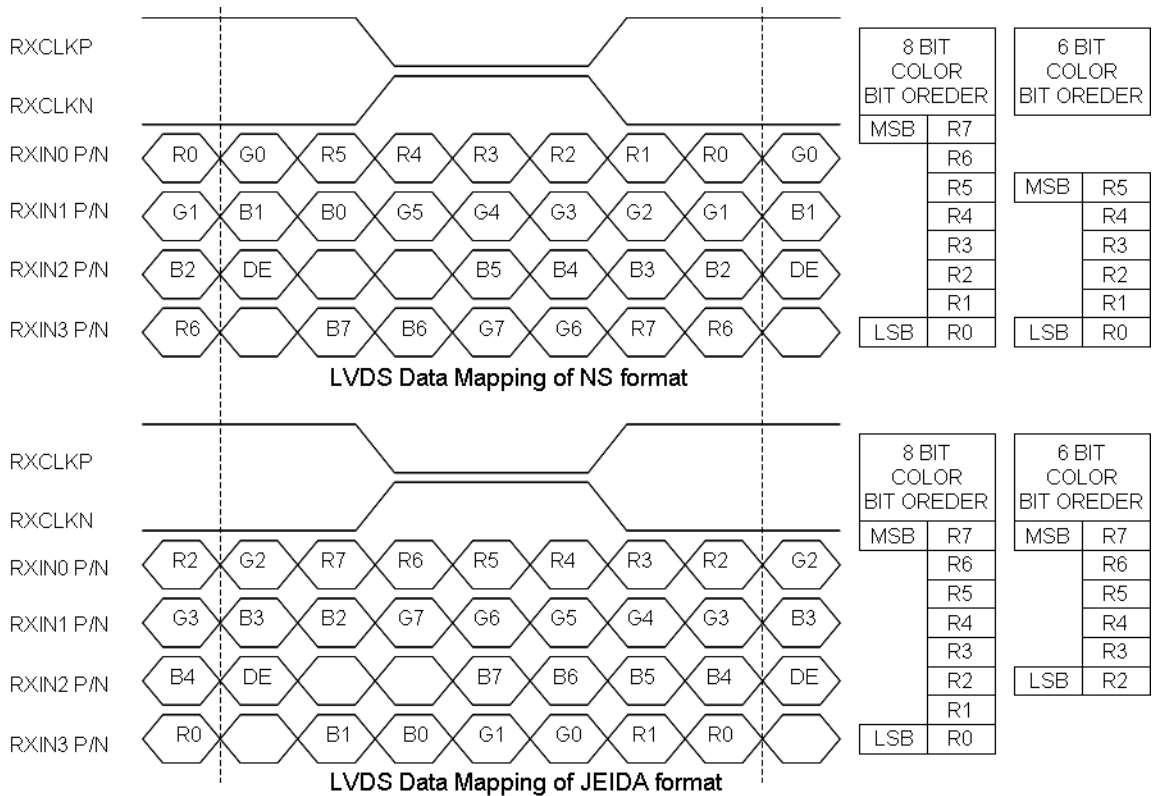

Note 1: Normally, DE, VS, HS on EVEN channel are not used

Note 2: 8-bit signal input.

6.3 Signal Description

The module using one LVDS receiver SN75LVDS82(Texas Instruments). LVDS is a differential signal technology for LCD interface and high speed data transfer device. Transmitter shall be SN75LVDS83(negative edge sampling). The LVDS port(RxNxxx) transmits input data pixels.

PIN#	Signal Name	DESCRIPTION
1	NC	No contact
2	NC	No contact
3	NC	No contact
4	GND	Power Ground
5	RXIN0-	Negative LVDS differential data (0)
6	RXIN0+	Positive LVDS differential data (0)
7	GND	Power Ground
8	RXIN1-	Negative LVDS differential data (1)
9	RXIN1+	Positive LVDS differential data (1)
10	GND	Power Ground
11	RXIN2-	Negative LVDS differential data (2)
12	RXIN2+	Positive LVDS differential data (2)
13	GND	Power Ground
14	RXCLKIN-	Negative LVDS differential data (clock)
15	RXCLKIN+	Positive LVDS differential data (clock)
16	GND	Power Ground
17	RXIN3-	Negative LVDS differential data (3)
18	RXIN3+	Positive LVDS differential data (3)
19	GND	Power Ground
20	NC	No contact
21	NC	No contact
22	NC	No contact
23	GND	Power Ground
24	GND	Power Ground
25	GND	Power Ground
26	VCC	+5V power supply
27	VCC	+5V power supply
28	VCC	+5V power supply
29	VCC	+5V power supply
30	VCC	+5V power supply

Note 1: Start from left side

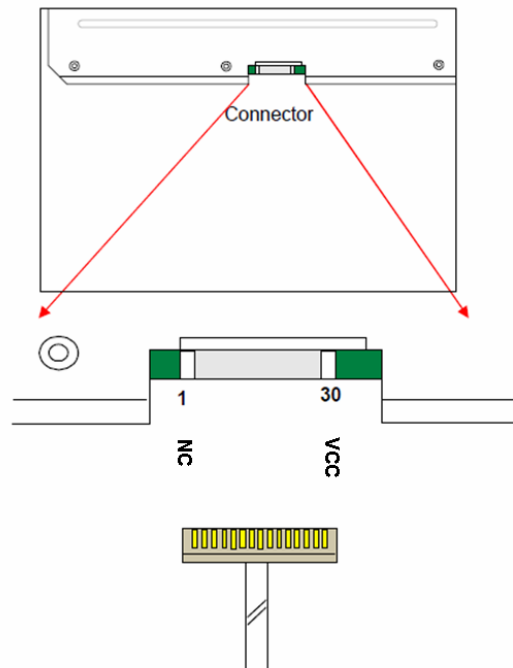

Note2: Input signals of clock shall be the same timing.

Note3: Please follow TV VESA Pin Assignment.

6.4. Timing Characteristics

Basically, interface timing described here is not actual input timing of LCD module but close to output timing of SN75LVDS82DGG (Texas Instruments) or equivalent.

Signal	Item	Symbol	Min	Typ	Max	Unit
V-section	Period	Tv	776	808	1023	Th
	Active	Tdisp(v)	768	768	768	Th
	Blanking	Tblk(v)	8	40	255	Th
H-section	Period	Th	1416	1606	2047	Tclk
	Active	Tdisp(h)	1366	1366	1366	Tclk
	Blanking	Tblk(h)	50	240	681	Tclk
Clock	Period	Tclk	-	12.8	-	ns
	Frequency	Freq	55	78	90	MHz
Frame Rate	Frame Rate	F	50	60	75	Hz

Note 1: DE mode only

Note2 : Clock Frequency 90MHz(Max.)= 1416(H)*847(V)*75Hz

6.5 Timing Diagram

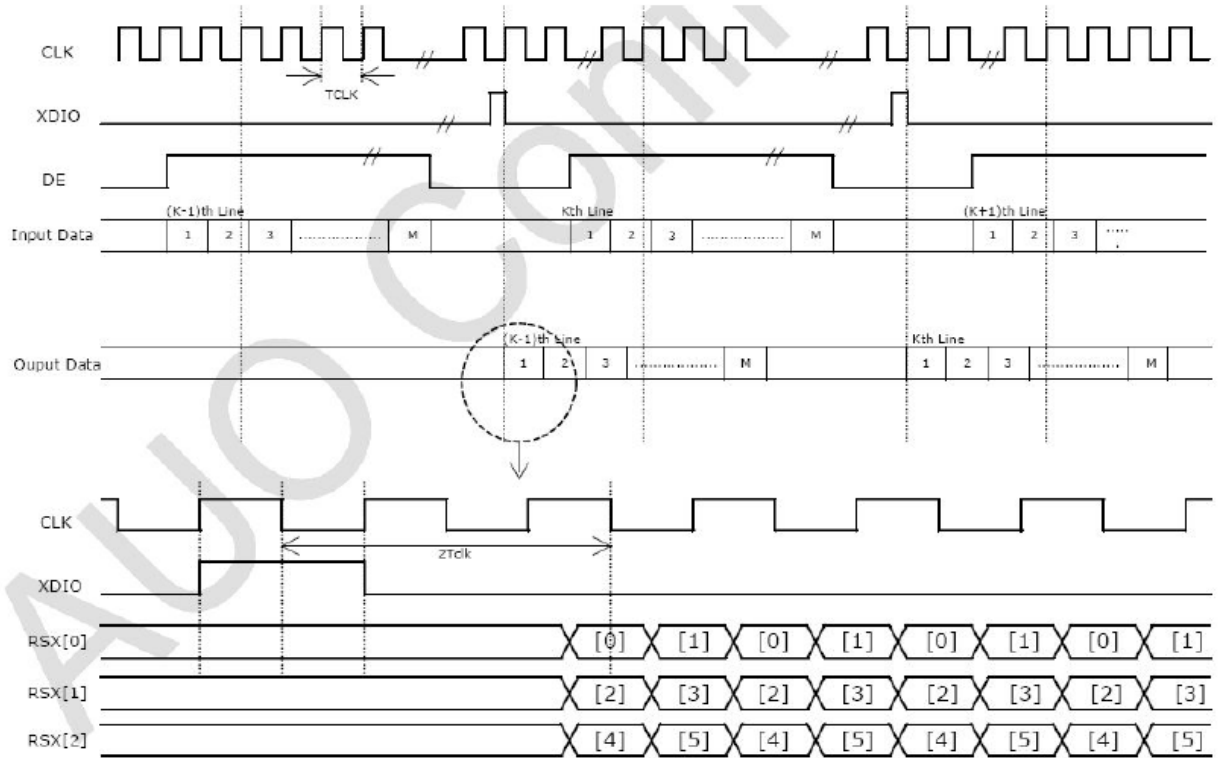

6.5 Power ON/OFF Sequence

VDD power and lamp on/off sequence is as follows. Interface signals are also shown in the chart. Signals from any system shall be Hi-Z state or low level when VDD is off.

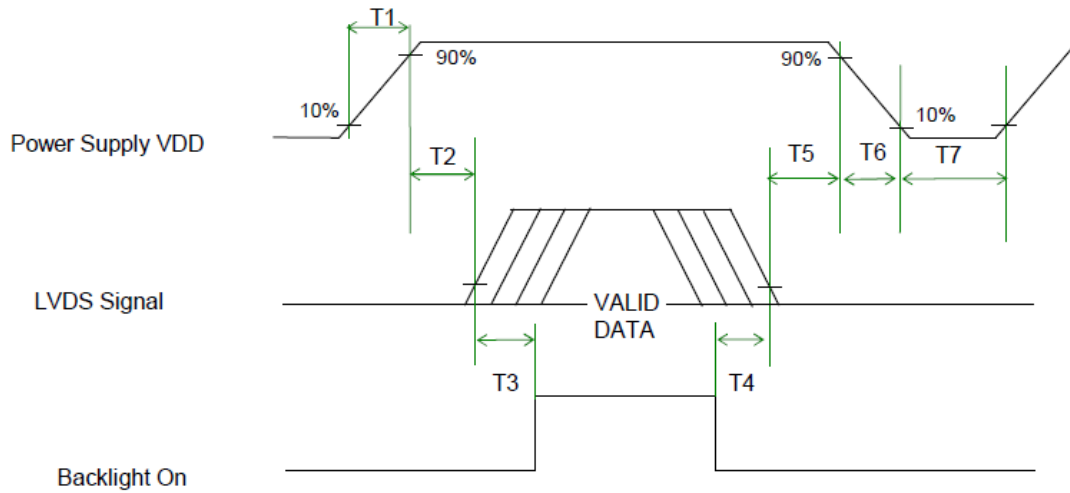

Parameter	Min.	Value		Unit
		Typ.	Max.	
T1	0.5	-	10	[ms]
T2	0	40	50	[ms]
T3	300	-	-	[ms]
T4	300	-	-	[ms]
T5	0.5	16	50	[ms]
T6	-	-	100	[ms]
T7	1000	-	-	[ms]

7.0 Connector & Pin Assignment

Physical interface is described as for the connector on module. These connectors are capable of accommodating the following signals and will be following components.

7.1 TFT LCD Module

Connector Name / Designation	Interface Connector / Interface card
Manufacturer	JAE / P-TWO
Type Part Number	FI-XB30SSRL-HF16 / AL230F-A0G1D-P
Mating Housing Part Number	FI-X30HL(Locked type)

7.1.1 Pin Assignment

Pin#	Signal Name	Pin#	Signal Name
1	NC	2	NC
3	NC	4	GND
5	RXIN0-	6	RXIN0+
7	GND	8	RXIN1-
9	RXIN1+	10	GND
11	RXIN2-	12	RXIN2+
13	GND	14	RXCLKIN-
15	RXCLKIN+	16	GND
17	RXIN3-	18	RXIN3+
19	GND	20	NC
21	NC	22	NC
23	GND	24	GND
25	GND	26	VCC
27	VCC	28	VCC
29	VCC	30	VCC

7.2 Backlight Unit

Pin No.	Symbol	I/O	Function	Remark
1	VLED+	P	Power for LED backlight anode	White
2	VLED-	P	Power for LED backlight cathode	Black

LED Light Bar Connector is used for the integral backlight system. The recommended model is BHSR-02VS-1 manufactured by JST.

8. Reliability Test

Environment test conditions are listed as following table.

Items	Required Condition	Note
Temperature Humidity Bias (THB)	Ta= 60°C, 80%RH, 300hours	
High Temperature Operation (HTO)	Ta= 50°C, 50%RH, 300hours	3
Low Temperature Operation (LTO)	Ta= -20°C, 300hours	
High Temperature Storage (HTS)	Ta= 60°C, 300hours	
Low Temperature Storage (HTS)	Ta= -20°C, 300hours	
Drop Test	Height: 60 cm, package test	
Thermal Shock Test (TST)	0°C/30min, 50°C/30min, 100 cycles	
On/Off Test	On/10sec, Off/10sec, 30,000 cycles	
ESD (ElectroStatic Discharge)	Contact Discharge: ± 8KV, 150pF(330Ω) 1sec, 9 points, 25 times/ point.	
	Air Discharge: ± 15KV, 150pF(330Ω) 1sec 9 points, 25 times/ point.	

Note 1: The TFT-LCD module will not sustain damage after being subjected to 100 cycles of rapid temperature change. A cycle of rapid temperature change consists of varying the temperature from -20°C to 60°C, and back again. Power is not applied during the test. After temperature cycling, the unit is placed in normal room ambient for at least 4 hours before power on.

Note 2: According to EN61000-4-2 , ESD class B: Some performance degradation allowed. No data lost. Self-recoverable. No hardware failures.

Note 3: The test items are tested by open frame type chassis.

9. Shipping Label & Package
(TBD)

10. Mechanical Characteristic

- NOTES:
1. BACKLIGHT: 2 COLD CATHODE FLUORESCENT LAMPS.
 2. I/F CONNECTOR.
 3. LAMP LIFE WITHOUT SPECIFIED TO BE 0.5 Yr.
 4. LAMP LIFE WITH SPECIFIED TO BE 3000HRS-40L.
 5. THIS DIMENSION EXCLUDES DEFORMATION.
 6. TORQUE OF M3 USER HOLE SHOULD BE WITHIN 3 KGF-CM AND RE-SCREW 10 TIMES.

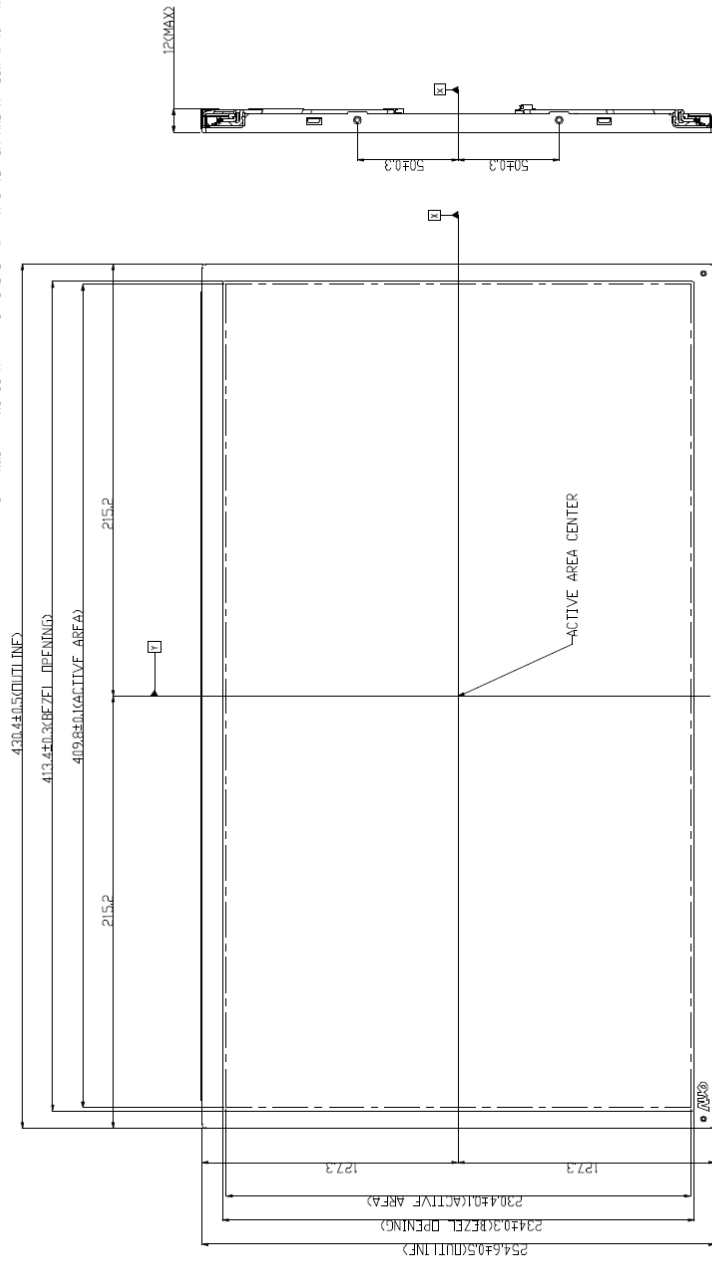

FRONT VIEW

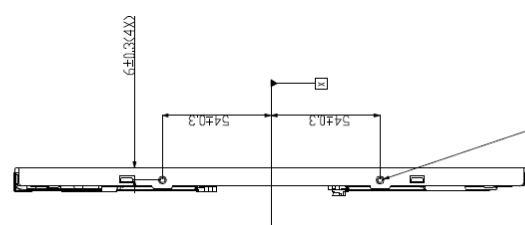

M3 SCREW USER HOLE
DP=4.0mm MAX SCREW PENETRATION



