

CUSTOMER' S APPROVAL SPECIFICATIONS

MODEL: CH%\$%#@ L-00&
(Complied with RoHS)



ISSUE:MAR.28.2013

Spec Condition: preliminary

No.	ITEM	PAGE
1	COVER	--
2	RECORD OF REVISION	0-1
3	MECHANICAL SPECIFICATIONS	1
4	OUTLINE DIMENSIONS	2
5	INTERFACE PIN CONNECTION	3
6	BLOCK DIAGRAM	4
7	ABSOLUTE MAXIMUM RATINGS	4
8	ELECTRICAL CHARACTERISTICS	5
9	OPTICAL CHARACTERISTICS	6~8
10	TIMING SPECIFICATIONS	9~10
11	RELIABILITY TEST	11
12	PRECAUTIONS FOR USE	12~13
13	LCM INSPECTION STANDARD	14~19

CUSTOMER	CHEFREE		
APPROVAL	APPROVAL	CHECKER	PREPARE
	<i>ch lee</i>	<i>kevin</i>	<i>kevin</i>

2.RECORD OF REVISION

Rev	DATE	PAGE	SUMMARY
0.1	2013.03.28	ALL	Preliminary specification was first issued.

3.MECHANICAL SPECIFICATIONS

(1)	Number Of Dots (Dots)	1024(R.G.B) X 600
(2)	Module Size(mm)	224.0(W) X 143.0(H) X 12.4(D)
(3)	Active Area(mm)	222.72(H) X 125.28(V)
(4)	Pixel Pitch(mm)	0.2175 (H) X 0.2088(V)
(5)	LCD Model	TFT , Transmissive, Normally/White
(6)	Polarizer Model	Anti-glare(3H)
(7)	LED Backlight Color	White
(8)	Viewing Direction	Wide Viewing Angle
(9)	Gray Scale Inversion Direction	12 O'CLOCK
(10)	Color Configuration	R.G.B Stripe
(11)	Module Weight(g)	400±10%

Distributed by:



www.texim-europe.com

5. INTERFACE PIN CONNECTION

5.1 LCM PANEL DRIVING SECTION

CN1:STM MSB240420HD or equivalent

PIN NO	SYMBOL	FUNCTION	REMARK
1	VDD	Power Supply,3.3V(typical)	
2	VDD	Power Supply,3.3V(typical)	
3	VSS	Ground	
4	REV	Reverse Scan selection	
5	Rin1-	LVDS receiver negative signal channel 0(G0,R5~R0)	
6	Rin1+	LVDS receiver positive signal channel 0(G0,R5~R0)	
7	VSS	Ground	
8	Rin2-	LVDS receiver negative signal channel 1(B1,B0,G5~G1)	
9	Rin2+	LVDS receiver positive signal channel 1(B1,B0,G5~G1)	
10	VSS	Ground	
11	Rin3-	LVDS receiver negative signal channel 2(DE,VS,HS,B5~B2)	
12	Rin3+	LVDS receiver positive signal channel 2(DE,VS,HS,B5~B2)	
13	VSS	Ground	
14	ClkIN-	LVDS receiver negative signal clock	
15	ClkIN+	LVDS receiver positive signal clock	
16	GND	Ground	
17	NC	No connection	
18	NC	No connection	
19	VSS	Ground	
20	NC	No connection	

5.2 BACKLIGHT SECTION

CN2:STM MSB24038P5A or equivalent

PIN NO	SYMBOL	FUNCTION	REMARK
1	VLED	Power Supply,12V(typical)	
2	GND	Ground	
3	EN	3.3V(typical)	
4	PWM	3.3V(typical)	
5	NC	Not connection	

6. BLOCK DIAGRAM

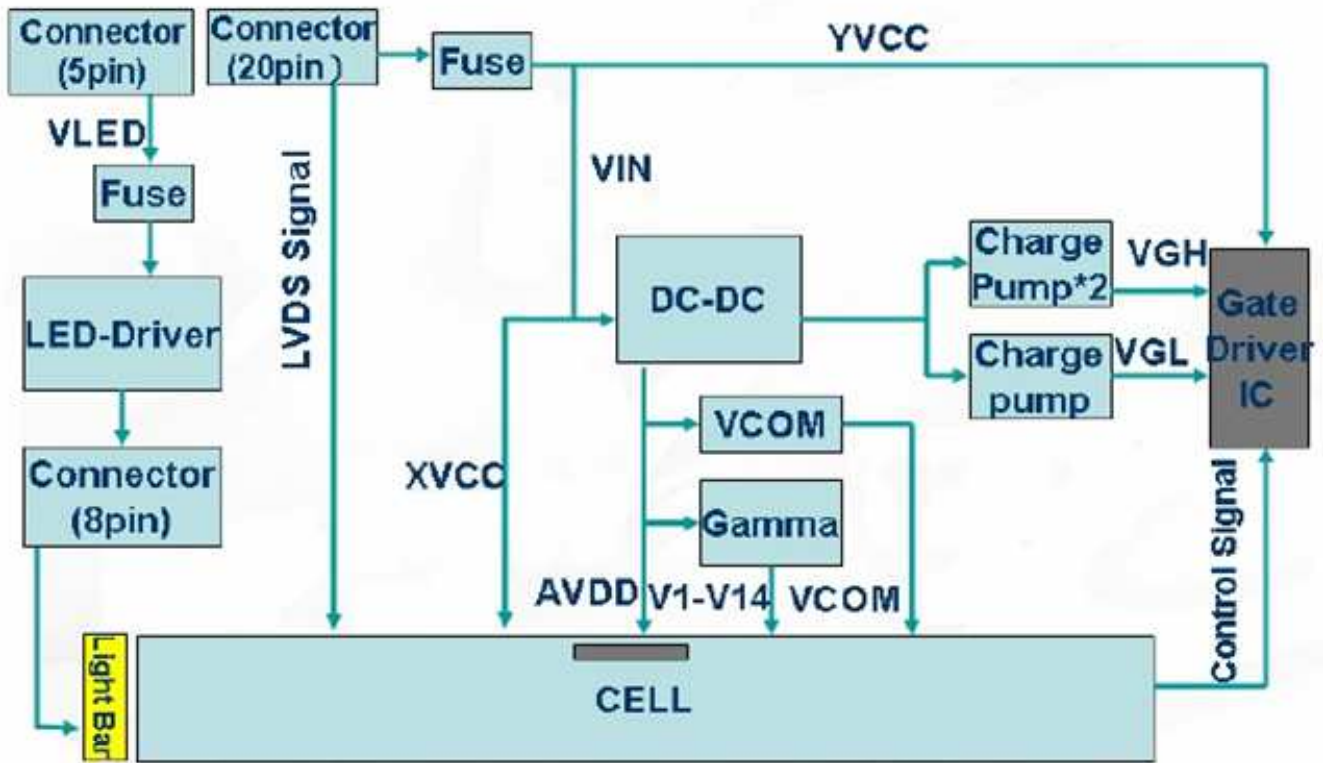

7. ABSOLUTE MAXIMUM RATINGS

7.1 ELECTRICAL ABSOLUTE MAXIMUM RATINGS

ITEM	SYMBOL	MIN.	MAX.	UNIT	REMARK
Logic Power Supply Voltage	VDD	3.0	3.6	V	
LED Backlight Drive Voltage	VLED	8.0	16.0	V	
LVDS Input Signal	V _S	-	3.6	V	
PWM Dimming Voltage	V _{PWM}	0.8	5.0	V	

7.2 ENVIRONMENTAL ABSOLUTE MAXIMUM RATINGS

ITEM	OPERATING		STORAGE		REMARK
	MIN	MAX	MIN	MAX	
Ambient Temperature(°C)	-30	85	-30	85	Note 1,2

Note 1 : The response time will become lower when operated at low temperature.

Note 2 : Background color changes slightly depending on ambient temperature.

8. ELECTRICAL CHARACTERISTICS

8.1 ELECTRICAL CHARACTERISTICS OF LCD

Ta=25°C

ITEM	SYMBOL	MIN.	TYP.	MAX.	UNIT	REMARK
Power Voltage For Digital	VDD	3.0	3.3	3.6	V	
	IDD**	-	-	153	mA	
Input Inrush Current	I _{RUSH}	-	-	1.5	A	
Input Power Voltage Ripple	V _{RPL}	-	-	200	mV	Vp-p
REV	VH	2.0	3.3	5.0	V	
	VL	-	-	0.8	V	
Logic Input Voltage (LVDS: Rin+, Rin-)	V _{CM}	1.0	1.2	1.4	V	V _{TH} -V _{TL} =200mV
	ΔV _{CM}	-50	-	+50	mV	V _{TH} -V _{TL} =200mV
	VID	200	-	600	mV	
	V _{TH}	-	-	+100	mV	V _{CM} =+1.2V
	V _{TL}	-100	-	-	mV	V _{CM} =+1.2V

**Test pattern is Black at 60Hz

8.2 BACKLIGHT UNITS

Ta=25°C

ITEM	SYMBOL	MIN.	TYP.	MAX.	UNIT	REMARK
LED Driving Voltage	VLED	8	12	16	V	
LED Driving Current	ILED	-	-	543	mA	
Brightness Control	VIH	2	3.3	5	V	
	VIL	0	-	0.8	V	
PWM Frequency	F _{PWM}	100		1K	Hz	
LED Life Time	-	50000	-	-	Hr	Note1

Note1 : The LED life time define as the estimated time to 50% degradation of the initial value.

9. OPTICAL CHARACTERISTICS

Ta=25°C

ITEM	SYMBOL	CONDITIONS	MIN.	TYP.	MAX.	UNIT	REMARK
Contrast Ratio	CR	Viewing	(400)	(500)	-	-	Note (1)
Response Time	T _R + T _F	Normal Angle Θ _x =Θ _y =0°	-	TBD	-	ms	Note (2)
Chromaticity	White	x	(0.255)	(0.305)	(0.355)	-	Note (4)
		y	(0.275)	(0.325)	(0.375)		
Viewing Angle	Hor.	Θ _x +	(70)	(80)	-	Deg.	Note (3)
		Θ _x -	(70)	(80)	-		
	Ver.	Θ _y +	(50)	(60)	-		
		Θ _y -	(70)	(80)	-		
Luminance	L	Center	(400)	(500)	-	cd/m ²	Note (4)
Luminance uniformity	YU	PWM=100%	70	80	-	%	Note (5)

*Note (1) Definition of Contrast Ratio (CR):

The contrast ratio can be calculated by the following expression.

$$\text{Contrast Ratio (CR)} = L_{63} / L_0$$

L63: Luminance of gray level 63

L 0: Luminance of gray level 0

$$CR = CR (5)$$

CR (X) is corresponding to the Contrast Ratio of the point X at Figure in Note (5).

*Note (2) Definition of Response Time (T_R, T_F):

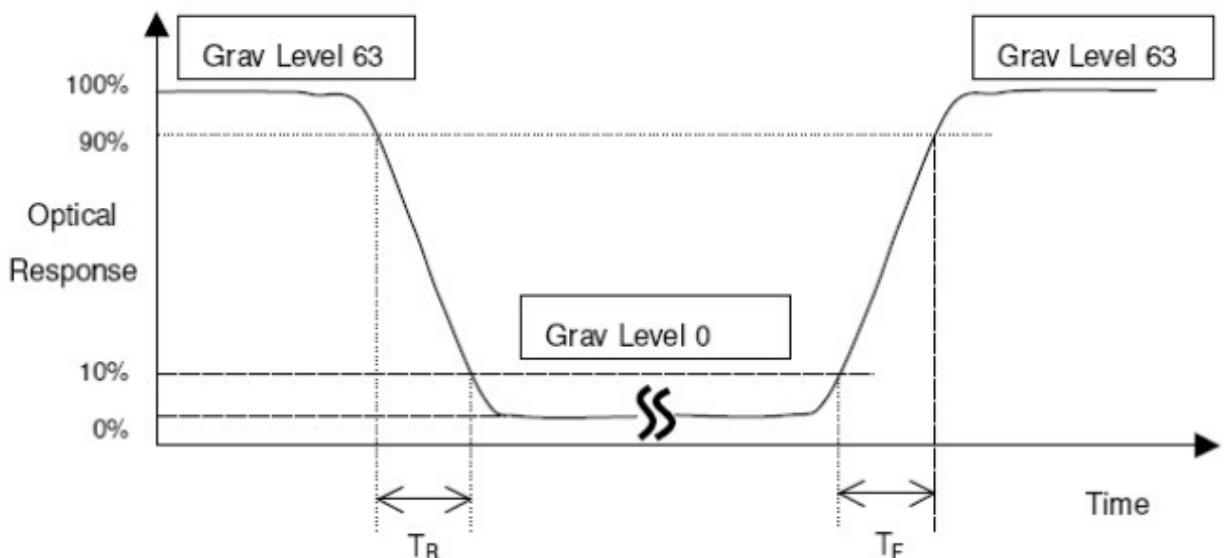

*Note(3) Definition of Viewing Angle

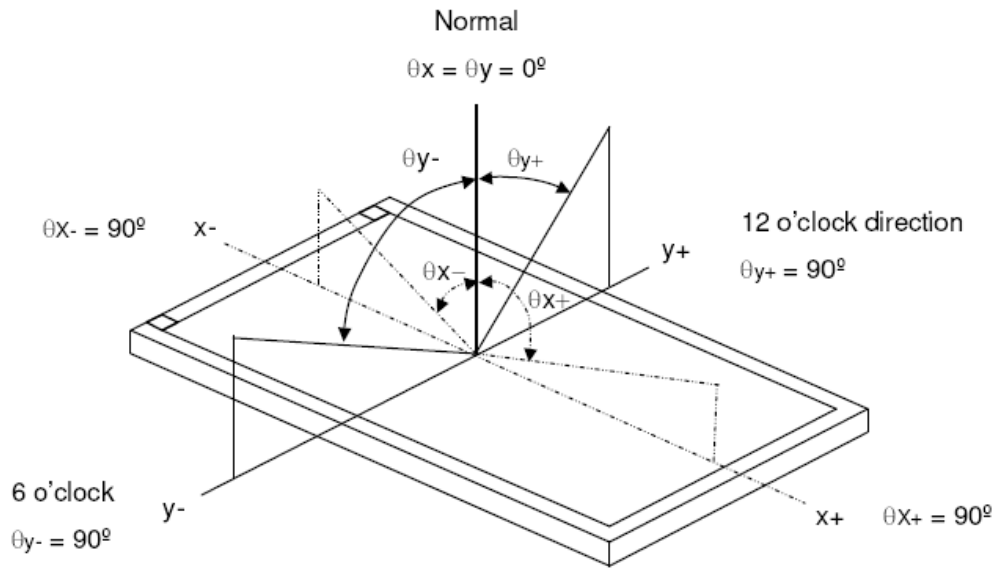

*Note (4) Measurement Set-Up:

The LCD module should be stabilized at a given temperature for 20 minutes to avoid abrupt temperature change during measuring. In order to stabilize the luminance, the measurement should be executed after lighting Backlight for 20 minutes in a windless room.

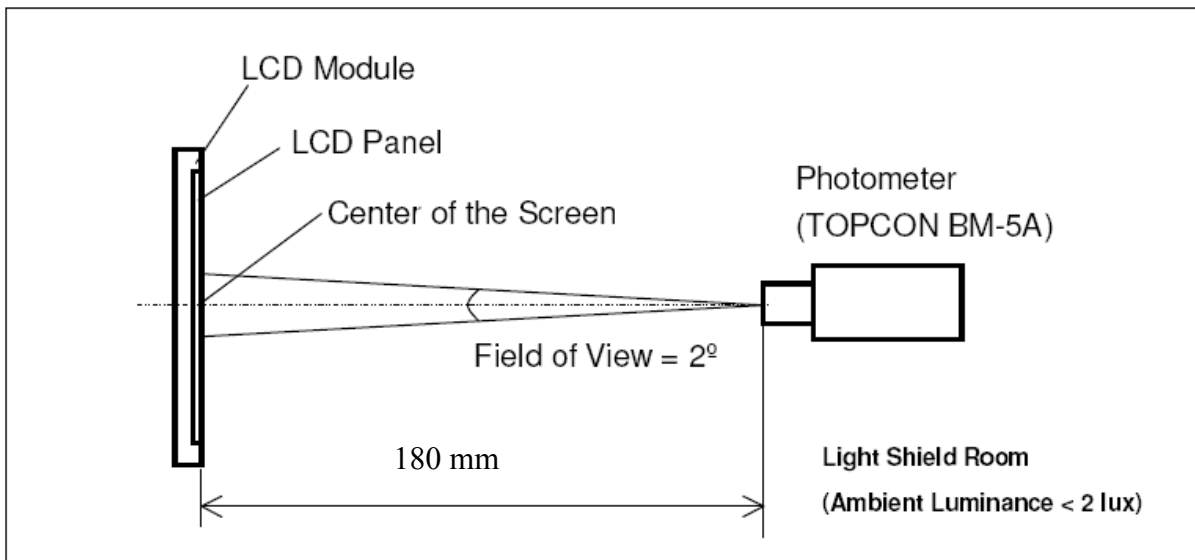

*Note (5)

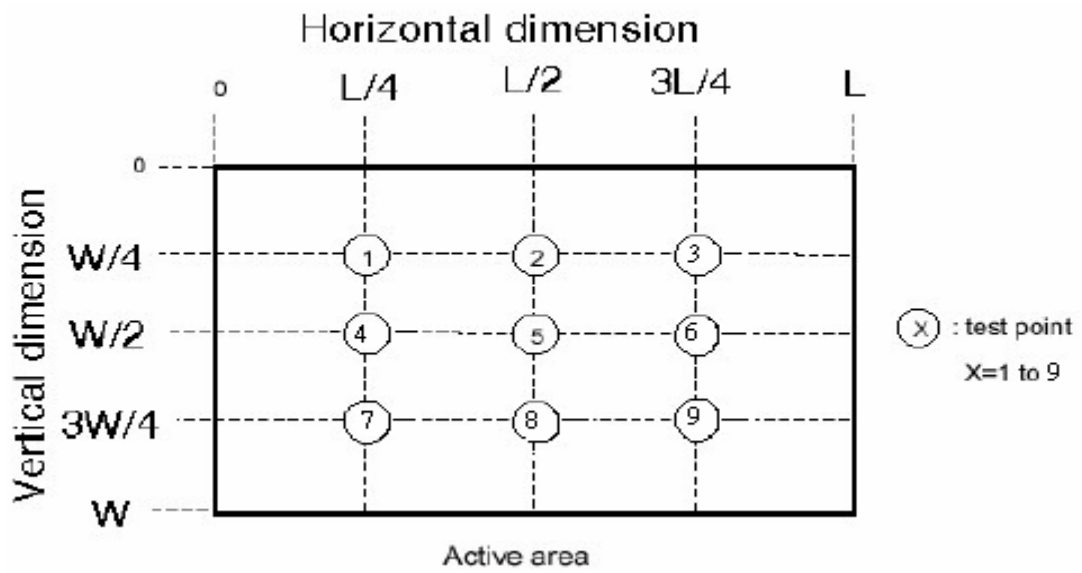

$$\left(1 - \frac{\text{MAX Luminance} - \text{Average Luminance}}{\text{Average Luminance}} \right) \times 100\% > 70\%$$

10. TIMING SPECIFICATIONS

10.1 POWER ON/OFF SEQUENCE

ITEM	SYMBOL	MIN.	TYP.	MAX.	UNIT	REMARK
VDD rising Time from 10% to 90%	T1	0.5	-	10	ms	
Delay from VDD to valid data at power ON	T2	0	-	50	ms	
Delay from valid data OFF to VDD OFF at power OFF	T3	0	-	50	ms	
VDD OFF time for Windows restart	T4	500	-	-	ms	
Delay from valid data to B/L enable at power ON	T5	200	-	-	ms	
Delay from valid data off to B/L disable at power OFF	T6	200	-	-	ms	
VDD falling time from 90% to 10%	T7	0	-	10	ms	
LED Vin rising time from 10% to 90%	T8	0.5	-	10	ms	
LED Vin falling time from 90% to 10%	T9	0.5	-	10	ms	
Delay from LED driver Vin rising time 90% to PWM ON	T10	0	-	10	ms	
Delay from PWM Off to LED Driver Vin falling time 10%, Must Keep rule	T11	0	-	-	ms	
Delay from PWM ON to B/L Enable ON, Must Keep rule	T12	0	-	-	ms	
Delay from B/L Enable Off to PWM Off	T13	0	-	-	ms	

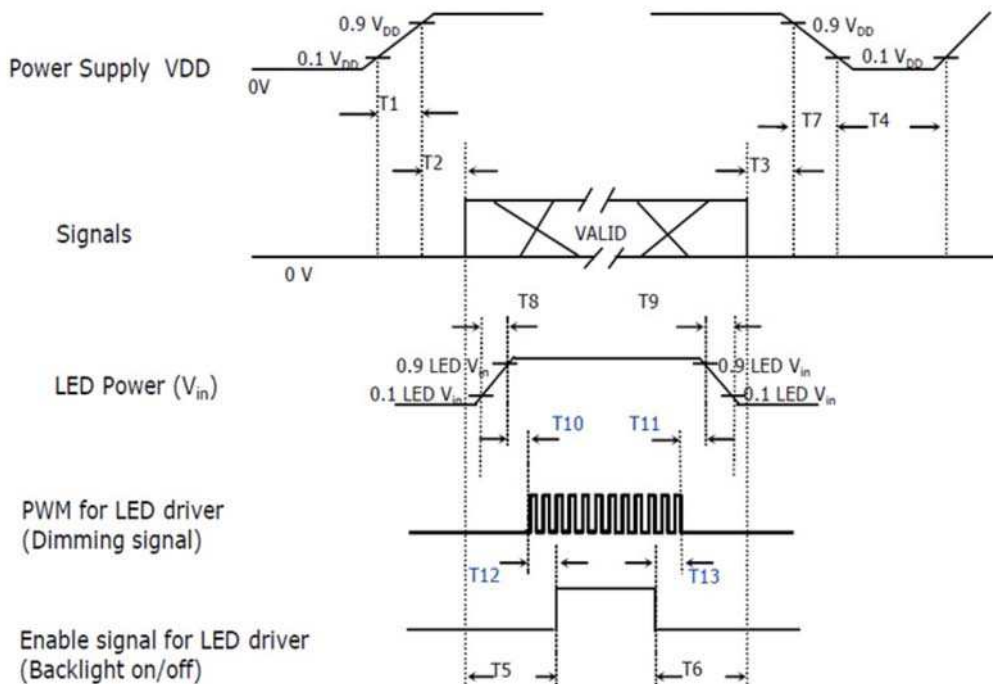

10.2 TIMING CHARACTERISTICS

Synchronization Method : DE only

ITEM	SYMBOL	MIN.	TYP.	MAX.	UNIT	REMARK
LVDS Clock Frequency (single)	f_{dck}	45	51.2	57	MHz	
H Total Time	T_{hp}	1324	1344	1364	clocks	
H Active Time	HA	1024	1024	1024	clocks	
H Blanking Time	TH_{BLANK}	300	320	340	clocks	
V Total Time	T_{VP}	625	635	645	lines	
V Active Time	VA	600	600	600	lines	
V Blanking Time	TV_{BLANK}	25	35	45	lines	
V Frequency	f_v	55	60	65	Hz	

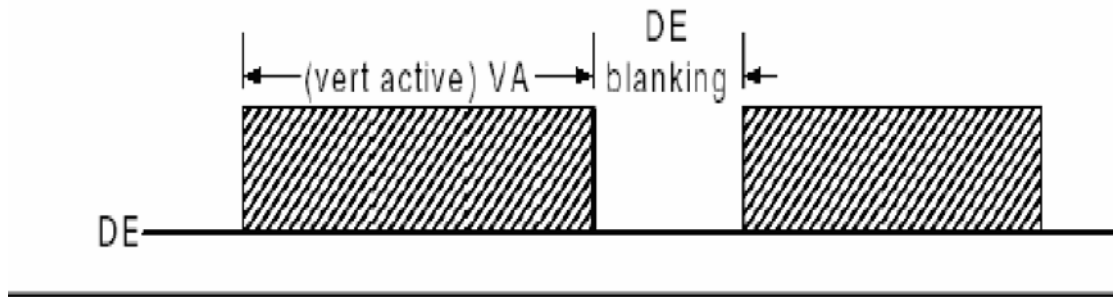

10.3 TIMING DIAGRAM OF INTERFACE SIGNAL

LVDS Mapping

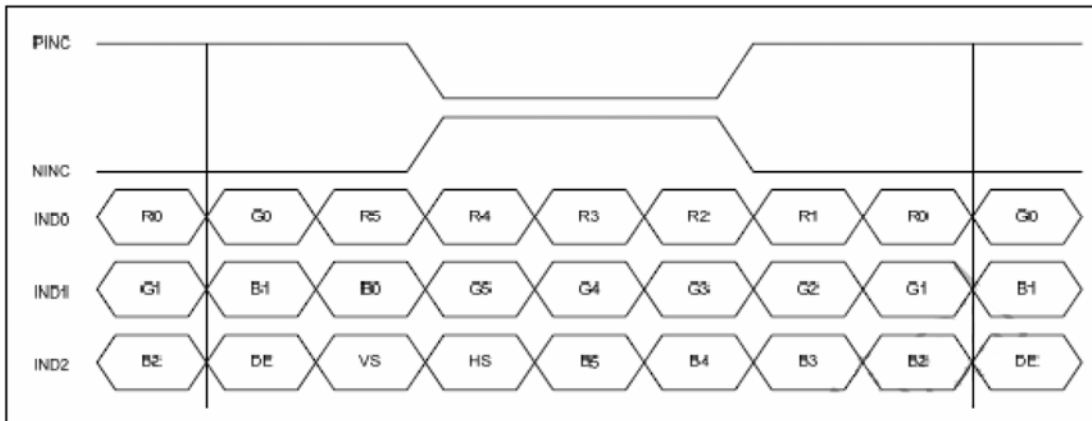

11. RELIABILITY TEST

ENVIRONMENTAL TEST FOR LCM				
NO.	ITEM	CONDITIONS	TIME PERIOD	REMARK
1	High Temperature Storage	85°C	500HRS	Note1,4
2	Low Temperature Storage	-30°C	500HRS	Note1,4
3	High Temperature Operation	85°C	500HRS	Note2,4
4	Low Temperature Operation	-30°C	500HRS	Note1,4
5	High Temperature Humidity Storage	50°C 95%RH	500HRS	Note2,4
6	Temperature Cycle	-40°C → 85°C (30min) (30min)	200CYCLE	Note1,4

Note1 : Ta is the ambient temperature of samples.

Note2 : Ts is the temperature of panel's surface.

Note3 : In the standard condition, there shall be no practical problem that may affect the display function. After the reliability test, the product only guarantees operation, but don't guarantee all of the cosmetic specification.

Note4 : Before cosmetic and function test, the product must have enough recovery time, at least 2 hours at room temperature.

12. PRECAUTIONS FOR USE

12.1 USE RESTRICTION

This product is not authorized for use in life supporting systems, aircraft navigation control systems, military systems and any other application where performance failure could be life-threatening or otherwise catastrophic.

12.2 HANDLING PRECAUTION

- (1) Please mount LCD module by using mounting holes arranged in four corners tightly.
- (2) Do not disassemble or modify the module. It may damage sensitive parts inside LCD module, and may cause scratches or dust on the display. CHEFREE does not warrant the module, if customers disassemble or modify the module.
- (3) If LCD panel is broken and liquid crystal spills out, do not ingest or inhale liquid Crystal, and do not contact liquid crystal with skin. If liquid crystal contacts mouth or eyes, rinse out with water immediately. If liquid crystal contacts skin or cloths, wash it off immediately with alcohol and Rinse thoroughly with water.
- (4) Disconnect power supply before handling LCD module
- (5) Refrain from strong mechanical shock and /or any force to the module.
- (6) Do not exceed the absolute maximum rating values, such as the supply voltage variation, input voltage variation, variation in parts' parameters, environmental temperature; etc otherwise LCD module may be damaged. It's recommended employing protection circuit for power supply.
- (7) Do not touch, push or rub the polarizer with anything harder than HB pencil lead. Use fingerstalls of soft gloves in order to keep clean display quality, when Persons handle the LCD module for incoming inspection or assembly.
- (8) When the surface is dusty, please wipe gently with absorbent cotton or other soft Material. When cleaning the adhesives, please use absorbent cotton wetted with a little Petroleum benzene or other adequate solvent.
- (9) Wipe off saliva or water drops as soon as possible. If saliva or water drops Contact with polarizer for a long time, they may causes deformation or color Fading.
- (10) Protection film must remove very slowly from the surface of LCD module to Prevent from electrostatic occurrence.
- (11) Because LCD module uses CMOS-IC on circuit board and TFT-LCD panel, it is Very weak to electrostatic discharge, Please be careful with electrostatic Discharge .Persons who handle the module should be grounded through adequate methods.
- (12) Do not adjust the variable resistor located on the module.

12.3 STORAGE PRECAUTION

- (1) Please do not leave LCD module in the environment of high humidity and high temperature for a long time.
- (2) The module shall not be exposed under strong light such as direct sunlight. Otherwise, Display characteristics may be changed.
- (3) The module should be stored in a dark place. It is prohibited to apply sunlight or fluorescent light in storage.

12.4 OPERATION PRECAUTION

- (1) Do not connect or disconnect the module in the "Power On" condition.
- (2) Power supply should always be turned on/off by 9.0 "Power on/off sequence"
- (3) Module has high frequency circuits. Sufficient suppression to the electromagnetic interference should be done by system manufacturers. Grounding and shielding methods may be important to minimize the interference.
- (4) After installation of the TFT Module into an enclosure, do not twist nor bend the TFT Module even momentary. At designing the enclosure, it should be taken into consideration that no bending/twisting forces are applied to the TFT Module from outside. Otherwise the TFT Module may be damaged.

12.5 OTHERS

- (1) Ultra-violet ray filter is necessary for outdoor operation.
- (2) Avoid condensation of water which may result in improper operation or disconnection of electrode
- (3) If the module keeps displaying the same pattern for a long period of time, the image may be "sticked" to the screen.
- (4) This module has its circuitry PCB's on the rear side and should be handled carefully in order not to be stressed.

12.6 DISPOSAL

When disposing LCD module, obey the local environmental regulations.

13. LCM INSPECTION STANDARD

13.1 INSPECTION AND ENVIRONMENT CONDITIONS

13.1.1 Inspection Conditions:

(1) Inspection Distance: 35 cm±5cm

(2) View Angle:

Light-on Inspection Angle : ±10°

Cosmetic Inspection Angle : ±10°

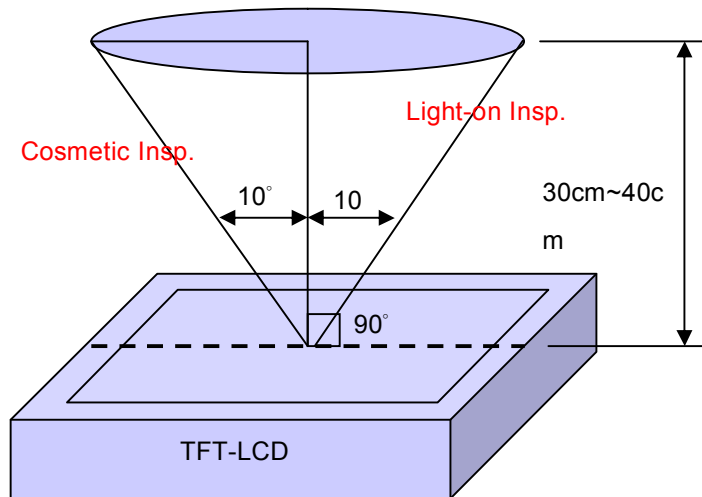

13.1.2 Environment Conditions:

Ambient Temperature		15~25°C
Ambient Humidity		25~75%RH
Ambient Illumination	Cosmetic Inspection	400~600 Lux
	Functional Inspection	100~200 Lux

13.1.3 Sampling Conditions:

(1) Lot Size: Quantity of shipment lot per model

(2) Sampling Method:

Sampling Plan		MIL-STD-105E
		Normal Inspection, Single Sampling Level II
AQL	Major Defect	0.5%
	Minor Defect	1.5%

(3) The classification of Major(MA) and Minor(MI) defects is shown as 4. Inspection Criteria.

13.2 INSPECTION CRITERIA

13.2.1 Cosmetic Inspection(Panel):

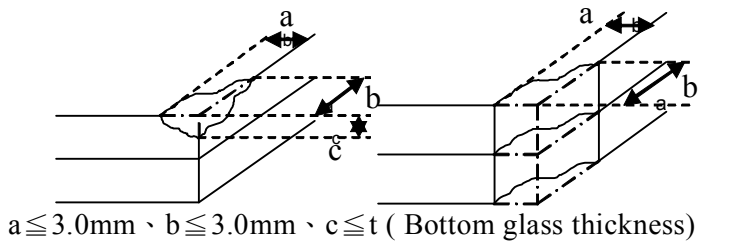
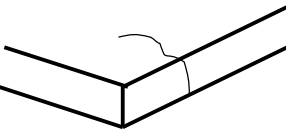
ITEM	JUDGMENT CRITERIA	CLASSIFICATION	ZONE
Chipping on Panel/Touch Panel	 <p>$a \leq 3.0\text{mm}$、$b \leq 3.0\text{mm}$、$c \leq t$ (Bottom glass thickness)</p>	MA	C
Scratch on Panel/Touch Panel *Note-2	$W \leq 0.03\text{mm}$: Ignored $0.03\text{mm} < W \leq 0.05\text{mm}$ and $L \leq 3.0\text{mm}$: $N \leq 4$ $0.05\text{mm} < W \leq 0.1\text{mm}$ and $L \leq 2.0\text{mm}$: $N \leq 2$ $W > 0.1\text{mm}$: Not allowed	MI	C
Bubble or Dent on Panel/Touch Panel *Note-3	$D \leq 0.2\text{mm}$: Ignored/不計 $0.2\text{mm} < D \leq 0.3\text{mm}$: $N \leq 2$ $D > 0.3\text{mm}$: Not allowed	MI	C
Panel/Touch Panel Crack	 <p>Not Allowed crack</p>	MA	C
Bezel Deformation	Obvious deformation is not allowed	MI	C
Bezel Oxidation	Not allowed if it rusts continuously over 1 cm (It is out of warranty with rusted tin plate)	MI	C
*Note-2 Bezel Scratch	Non-feeling abrasion: Ignored feeling abrasion , $L \leq 20\text{mm}$, $W \leq 0.3\text{ mm}$, $N \leq 7$ Not allowed	MI	C
*Note-3 Metal Squash Dent /Flange(Front Side)	$D(W) \leq 1\text{ mm}$, $L \leq 3$, $N \leq 4$;	MI	C
B/L High Voltage Wire Denudation	Not allowed	MA	C
Polarizer flaw or leak out resin	Defect is defined as the active area.	MI	C
Outline Dimension	Must in Spec, refer to related product spec.	MI	C

13.2.2 Functional Inspection:

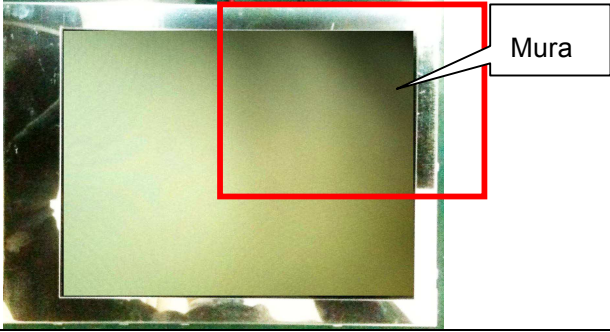
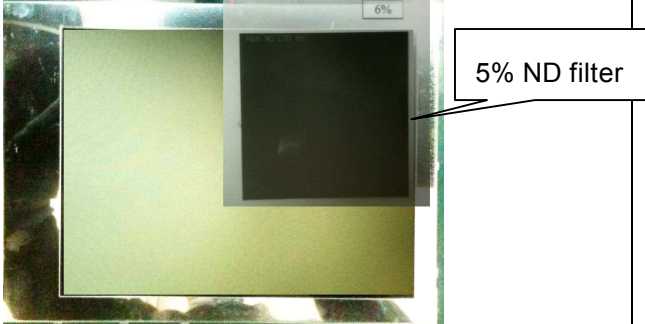
ITEM	JUDGMENT CRITERIA			CLASSIFICATION	ZONE
Point Defect *Note-6~10	Bright dot	Random	3	MI	A
		2 dots adjacent	1		
	Dark dot	Random	3		
		2 dots adjacent	1		
	Total Dot Defect				
	Distance *Note-11	Distance between Bright and Bright dot	$L \geq 15\text{mm}$		
		Distance between Bright and Dark dot	$L \geq 15\text{mm}$		
		Distance between Dark dot	$L \geq 5\text{mm}$		
	Bubble	Average diameter D(mm)	Maximum number acceptable	MI	A , B
		$D \leq 0.3$	Ignore		
$0.3 < D \leq 1.0$		$N \leq 3$			
$1.0 < D \leq 1.5$		$N \leq 1$			
Line Defect	Obvious vertical or horizontal line defect is not allowed.			MA	A , B
Mura	1. Mura Definition: Under the normal examination angle of view, the picture has the non-uniform phenomenon. 			MI	A , B
	2. Weak defect will be defined as Mura if it can be Observed through ND filter 5% 				

ITEM	JUDGMENT CRITERIA	CLASSIFICATION	ZONE
*Note-4 Foreign Material in spot shape	$D \leq 0.15\text{mm}$: Ignored $0.15\text{mm} < D \leq 0.5\text{mm}$: $N \leq 4$, $0.3\text{mm} < D \leq 0.5\text{mm}$: $N \leq 3$ $D > 0.5\text{mm}$: Not allowed	MI	A
*Note-3 Foreign Material in line or spiral shape	$W \leq 0.03\text{mm}$: Ignored $0.03\text{mm} < W \leq 0.1\text{mm}$ and $L \leq 5\text{mm}$: $N \leq 4$ $W > 0.1\text{mm}$ or $L > 5\text{mm}$ Not allowed	MI	
Display Function Abnormal	No Malfunction can be allowed	MA	A , B
Touch panel Malfunction	No Malfunction can be allowed in AA area.	MA	

Note 1 : I/O Area Definition

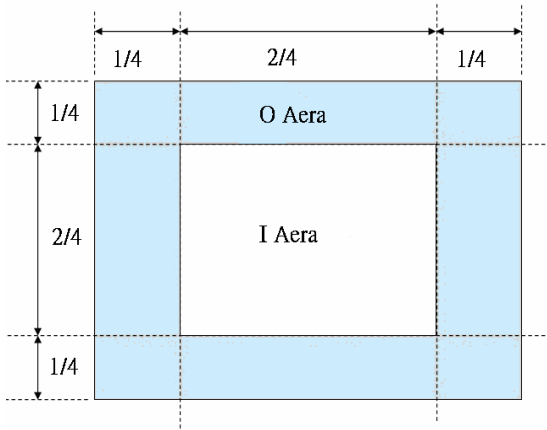

Note 2 : Polarizer Scratch

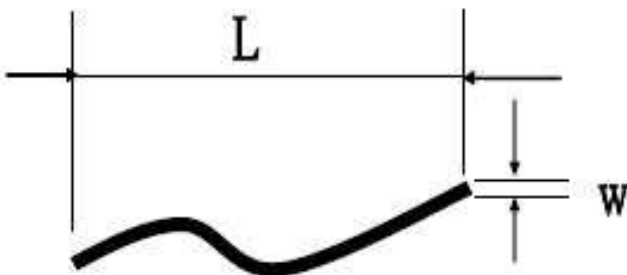

Note 3 : Line or Spiral Foreign Material

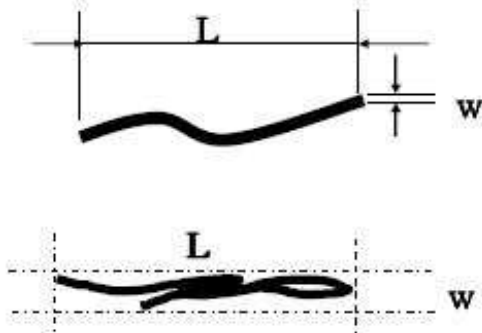

Note 4 : Spot Foreign Material

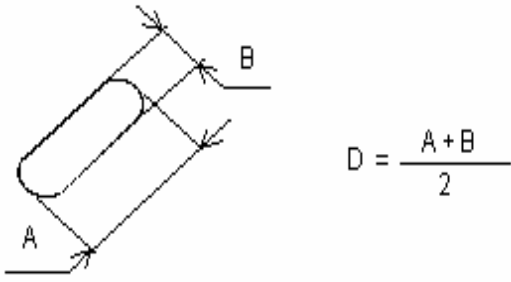

Note 5 : TP Inspection Area Definition

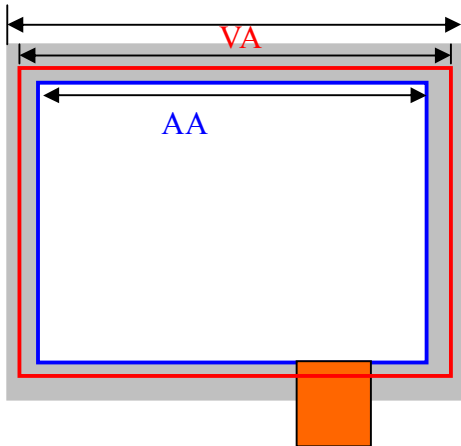

Note 6 : Bright dot defect description:

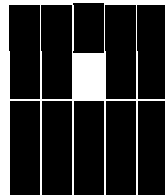

Note 7 : Dark dot defect description:

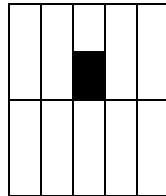

Note 8 : Bright dot defect description- Two adjacent.

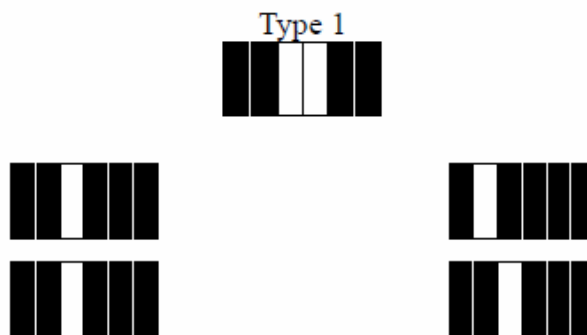

Note 9 : Dark dot defect description- Two adjacent.

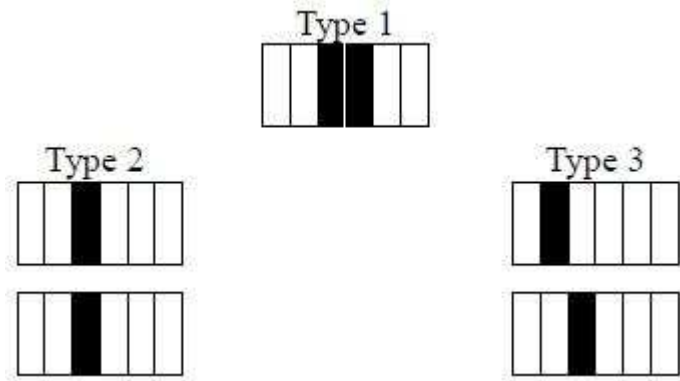

Note 10 : Dark dot defect description- Three adjacent.

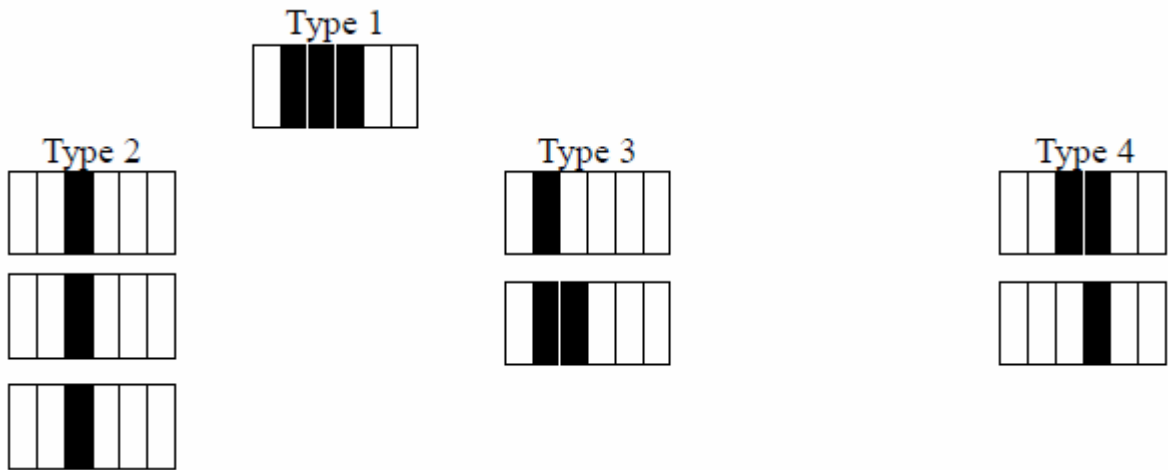

Note 11 : Distance between dot defects

Bright dot to bright dot.

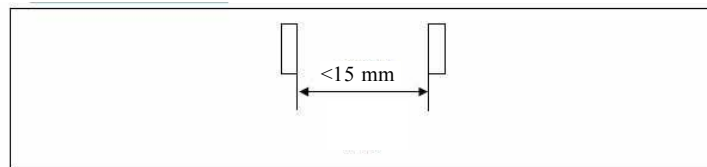

Dark dot to dark dot

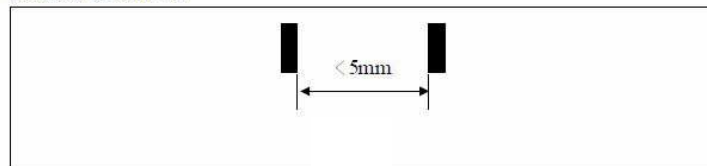

Bright dot to dark dot

