

## CUSTOMER' S APPROVAL SPECIFICATIONS

**MODEL: CH0700LFL-TS2**

**(Complied with RoHS)**



**ISSUE:SEP.15.2013**

**Spec Condition: preliminary**

No.	ITEM	PAGE
1	COVER	--
2	RECORD OF REVISION	0-1
3	MECHANICAL SPECIFICATIONS	1
4	OUTLINE DIMENSIONS	2
5	INTERFACE PIN CONNECTION	3
6	BLOCK DIAGRAM	4
7	ABSOLUTE MAXIMUM RATINGS	4
8	ELECTRICAL CHARACTERISTICS	5~7
9	OPTICAL CHARACTERISTICS	8~10
10	TIMING SPECIFICATIONS	11~14
11	RELIABILITY TEST	15
12	PACKAGE METHOD	16

CUSTOMER	CHEFREE		
APPROVAL	APPROVAL	CHECKER	PREPARE
	ch lee	ch lee	kevin

## 2.RECORD OF REVISION

Rev	DATE	PAGE	SUMMARY
0.1	2013.09.25	ALL	Preliminary specification was first issued.

### 3.MECHANICAL SPECIFICATIONS

(1)	Number Of Dots (Dots)	1024(R.G.B) X 600
(2)	Module Size(mm)	165.5(W) X 104.4(H) X 7.05(D)
(3)	Active Area(mm)	153.6(H) X 90.0(V)
(4)	Pixel Pitch(mm)	0.15 (H) X 0.15(V)
(5)	LCD Model	TFT , Transmissive, Normally/White
(6)	Polarizer Model	Clear, 1% surface light reflection
(7)	LED Backlight Color	White
(8)	Viewing Direction	12 O'clock
(9)	Gray Scale Inversion Direction	6 O'clock
(10)	Color Configuration	R.G.B Stripe
(11)	Module Weight(g)	TBD

\*\*This is a sunlight readable display with TSD enhanced for applying under direct sunlight environment  
The ambient light reflection for panel backlight is 1.5% rate!

Distributed by:



[www.texim-europe.com](http://www.texim-europe.com)

4. OUTLINE DIMENSIONS

1	2	3	4
文件題目	圖號	頁	次頁
發行日	舊版日	登入號碼	機密等級

6	7	8
No.	修訂內容	樣式 QT2-RD02-008
	新版	作成 Swallow
		修訂日期 2013.01.07

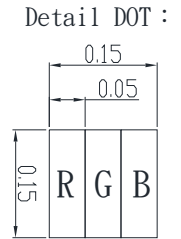
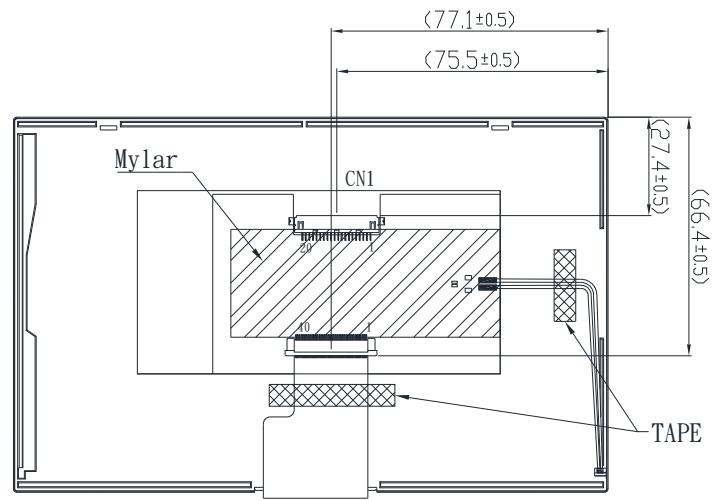
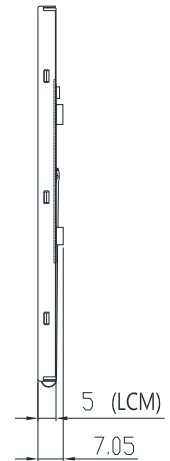
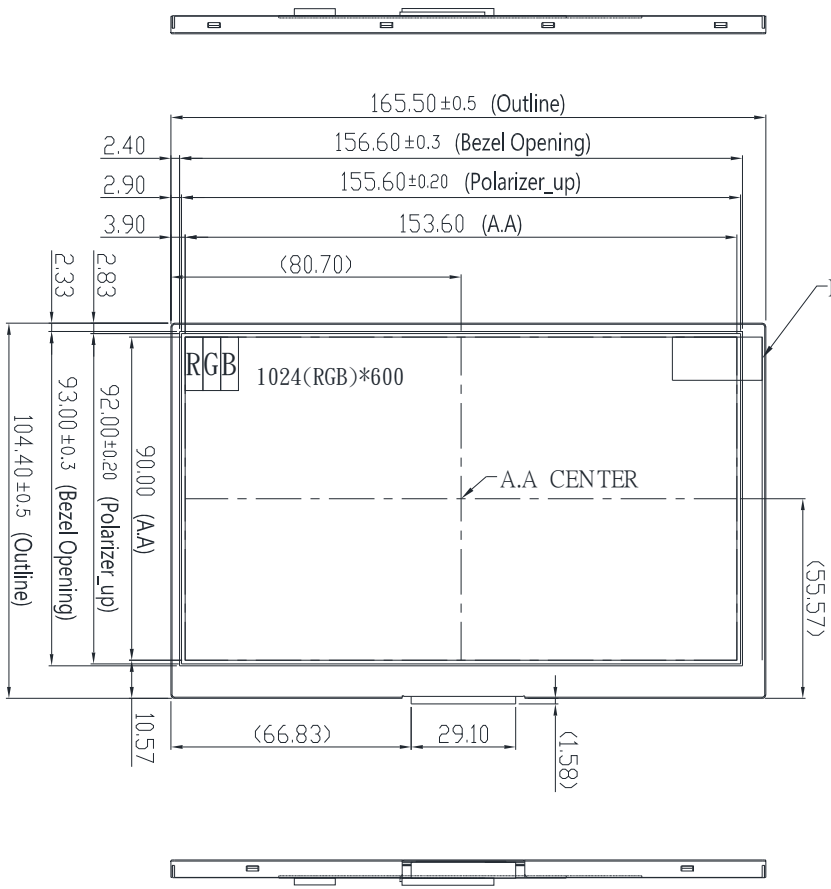

NOTE:  
 1. Unit: mm  
 2. Tolerance is ±0.3mm unless noted .  
 3. CN1:MSB24013P20HA or Equivalent .

備考	單位:mm		投影法:	比例尺:
入庫	製圖 Swallow	130107	名稱: 7" 1024*600 LCM	圖號 CH0700LFL-TS2
	審查			
	承認			

## 5. INTERFACE PIN CONNECTION

### 5.1 LCM PANEL DRIVING SECTION (CN1: MSB24013P20HA or Equivalent)

PIN NO.	SIGNAL	FUNCTION	REMARK
1	VDD	Power Voltage for digital circuit	
2	VDD	Power Voltage for digital circuit	
3	U/D	Up/Down Scan	Note 1
4	L/R	Left/Right Scan	Note 1
5	RXIN0-	Differential data Input,CH0(G0,R0~R5)	
6	RXIN0+	Differential data Input,CH0(G0,R0~R5)	
7	GND	Ground	
8	RXIN1-	Differential data Input,CH1(B0,B1,G1~G5)	
9	RXIN1+	Differential data Input,CH1(B0,B1,G1~G5)	
10	GND	Ground	
11	RXIN2-	Differential data Input,CH2(DE,B2~B5)	
12	RXIN2+	Differential data Input,CH2(DE,B2~B5)	
13	GND	Ground	
14	RXCLKIN-	Differential Clock Input	
15	RXCLKIN+	Differential Clock Input	
16	GND	Ground	
17	RXIN3-	Differential data Input,CH3(B6,B7,G6,G7,R6,R7)	
18	RXIN3+	Differential data Input,CH3(B6,B7,G6,G7,R6,R7)	
19	VLED	LED Driving Voltage	
20	ADJ	LED ADJ dimming	

Note1:

U/D	L/R	FUNCTION
0	1	Normal display
0	0	Inverse Left and Right
1	1	Inverse Up and Down
1	0	Inverse Left and Right Inverse Up and Down

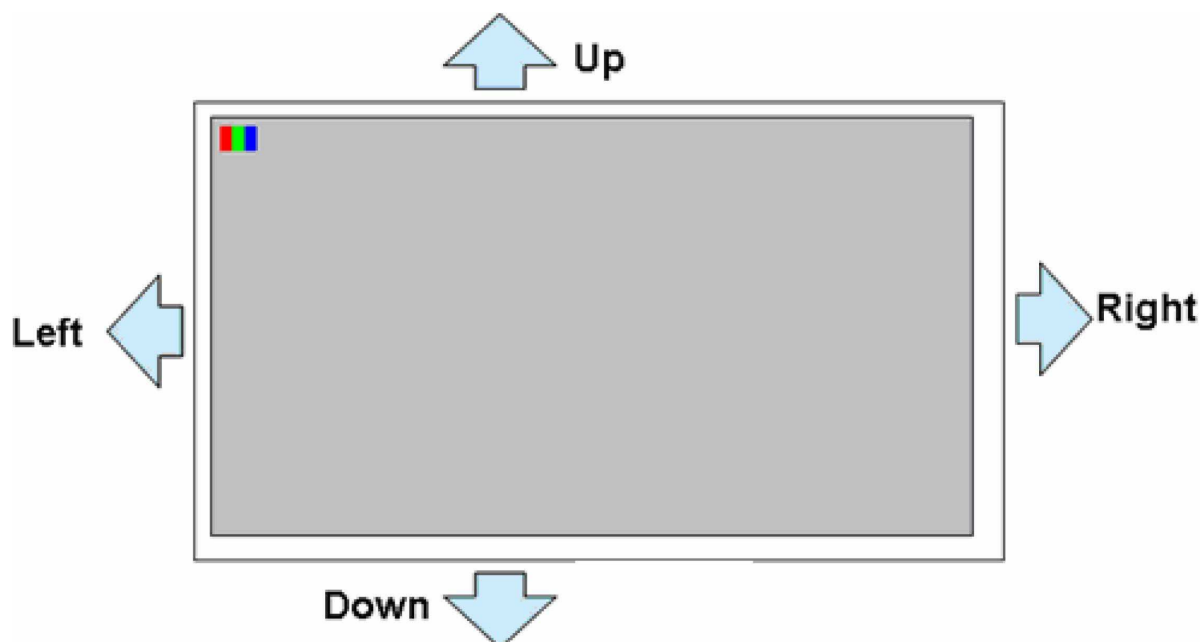

## 6. BLOCK DIAGRAM

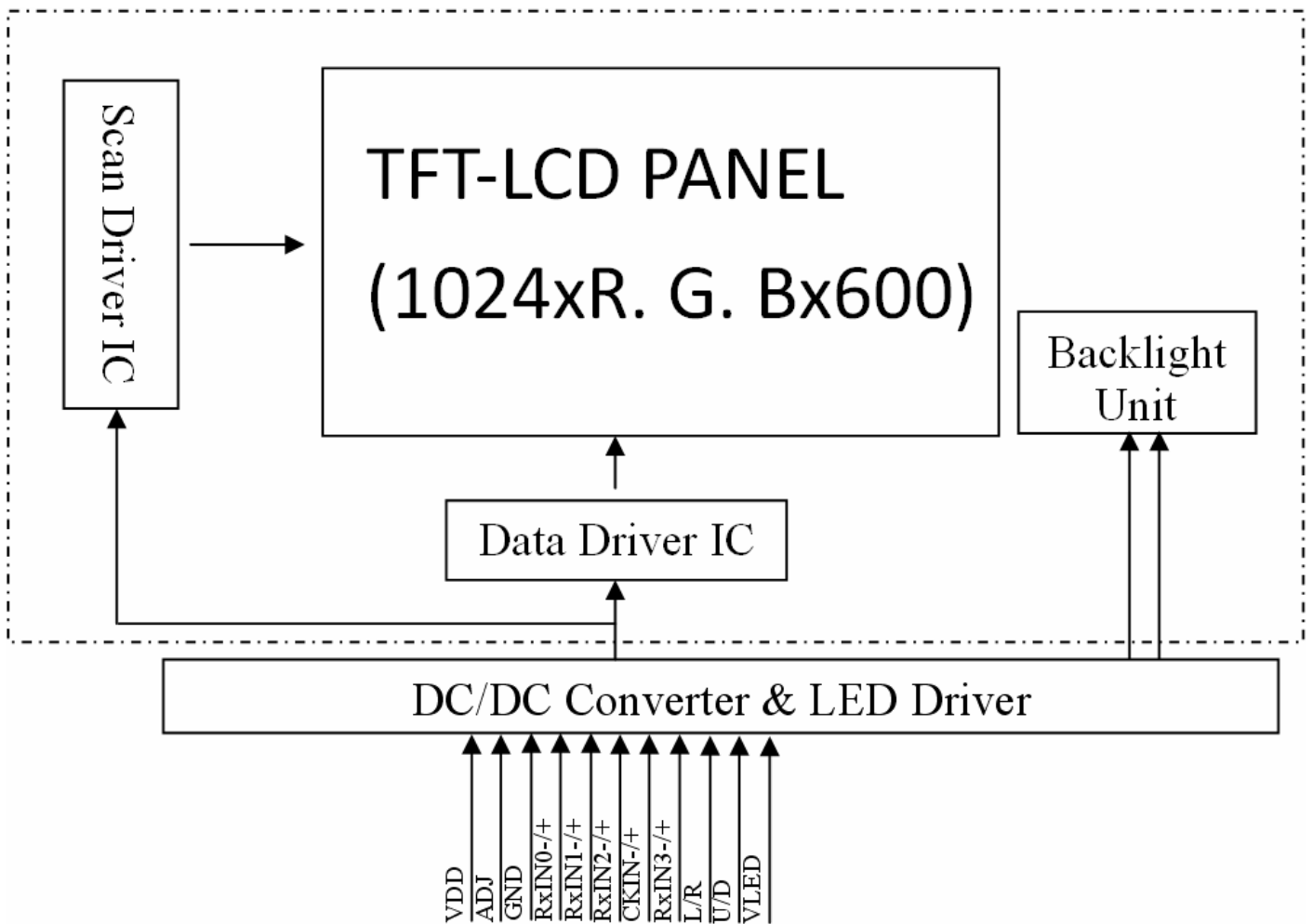

## 7. ABSOLUTE MAXIMUM RATINGS

### 7.1 ELECTRICAL ABSOLUTE MAXIMUM RATINGS

ITEM	SYMBOL	MIN.	MAX.	UNIT	COMMENT
Power Supply Voltage For Digital	VDD	-0.3	5.0	V	
Logic Output Voltage	V <sub>I</sub>	-0.5	5.0	V	

### 7.2 ENVIRONMENTAL ABSOLUTE MAXIMUM RATINGS

ITEM	OPERATING		STORAGE		COMMENT
	MIN	MAX	MIN	MAX	
Ambient Temperature(°C)	-20	70	-30	80	Note 1,2,3
Humidity(% RH)	-	90	-	90	Note 4

Note 1 : The response time will become lower when operated at low temperature.

Note 2 : Background color changes slightly depending on ambient temperature.

Note 3 : Operation Ta=70°C & -20°C ≤ 240Hrs.

Note 4 : Storage Ta=60°C & H=90% ≤ 240Hrs.

## 8. ELECTRICAL CHARACTERISTICS

### 8.1 ELECTRICAL CHARACTERISTICS OF LCD

Ta=25°C

ITEM	SYMBOL	MIN.	TYP.	MAX.	UNIT	REMARK
Power Voltage For Digital	VDD	3.0	3.3	3.6	V	
	IDD*	-	(150)	-	mA	VDD=3.3V
Input High Voltage	V <sub>IH</sub>	0.7 x VDD	-	VDD	V	
Input Low Voltage	V <sub>IL</sub>	GND	-	0.3 x VDD	V	
Logic Input Voltage (LVDS: IN+, IN-)	V <sub>CM</sub>	VID /2	-	2.4- VID /2	V	Note1
	VID	200	-	600	mV	Note1
	V <sub>TH</sub>	-	-	100	mV	V <sub>CM</sub> =1.2V
	V <sub>TL</sub>	-100	-	-	mV	

\*Test pattern Black.

Note1 : LVDS signal

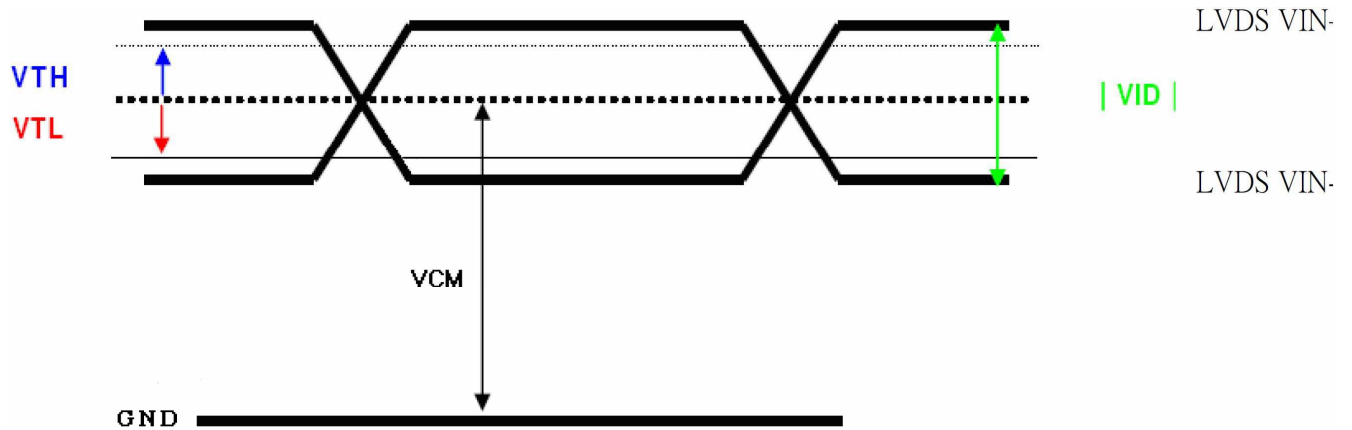

## 8.2 BACKLIGHT UNITS

Ta=25°C

ITEM	SYMBOL	MIN.	TYP.	MAX.	UNIT	
LED Driving Voltage	VLED	11.7	12	12.3	V	
LED Driving Current	ILED	-	220	300	mA	
Brightness Control	Analog dimming	ADJ	0.7	-	1.4	V <sub>DC</sub>
	PWM dimming		1.4	-	5.0	V <sub>P-P</sub>
ADJ Frequency	-	100	-	1000	Hz	
LED Life Time	-	50000	-	-	Hr	

Note 1: If the module is driven at high ambient temperature & humidity condition. The operating life will be reduced.

Note 2: Operating life means brightness goes down to 50% initial brightness. Typical operating life time is estimated data.

Note 3: When the ADJ pin voltage rises from 0.7VDC to 1.4VDC, the LED current will change from 0% to 100% of the maximum LED current.

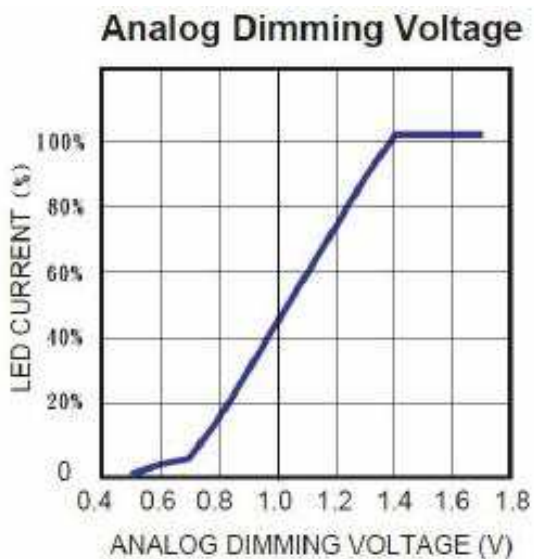



Note 4: ADJ signal  $V_{p-p} = 1.4 \sim 5.0V$ , operation frequency:  $100Hz \sim 1 kHz$

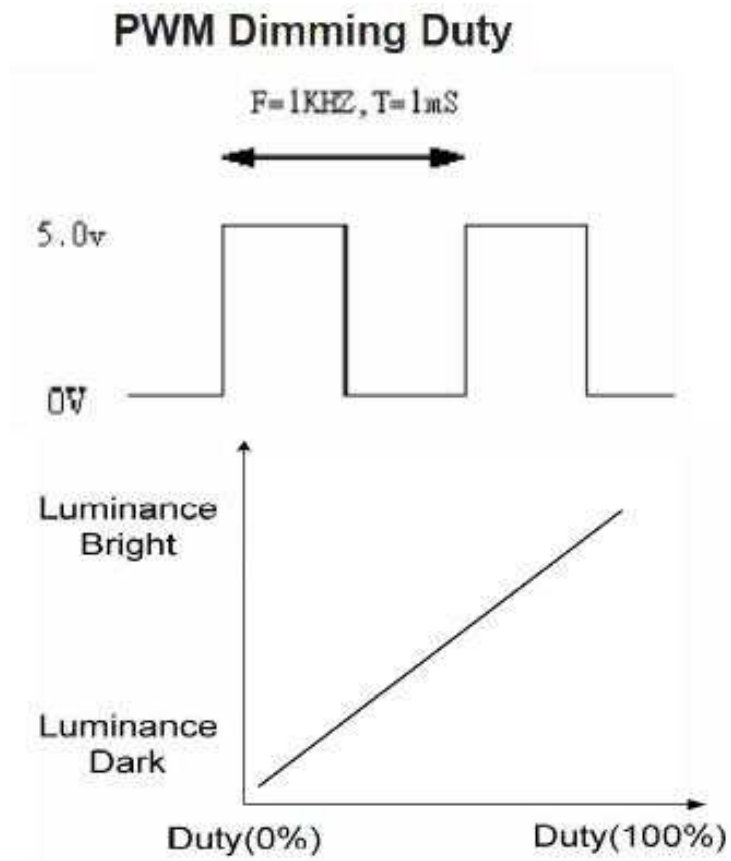

## 9. OPTICAL CHARACTERISTICS

Ta=25°C

ITEM	SYMBOL	CONDITIONS	MIN.	TYP.	MAX.	UNIT	REMARK	
Contrast Ratio	CR	Viewing	500	700	-	-	Note (1)	
Response Time	TR+TF	Normal	-	25	50	ms	Note (2)	
Chromaticity	White	x	(0.249)	(0.299)	(0.349)	-	Note (4)	
		y	(0.273)	(0.323)	(0.373)	-		
Viewing Angle	Hor.	$\Theta_{X+}$	Viewing	65	75	-	Deg.	Note (3)
		$\Theta_{X-}$	Angle	65	75	-		
	Ver.	$\Theta_{Y+}$	$\Theta_{X}=\Theta_{Y}$	60	70	-		
		$\Theta_{Y-}$	$=0^{\circ}$ CR $\geq 10$	65	75	-		
Luminance	L		(500)	(550)	-	cd/m <sup>2</sup>		
Luminance uniformity	YU	PWM=100%	70	-	-	%	Note (5)	

\*Note (1) Definition of Contrast Ratio (CR):

The contrast ratio can be calculated by the following expression.

$$\text{Contrast Ratio (CR)} = L_{63} / L_0$$

L63: Luminance of gray level 63

L 0: Luminance of gray level 0

$$CR = CR (5)$$

CR (X) is corresponding to the Contrast Ratio of the point X at Figure in Note (5).

\*Note (2) Definition of Response Time ( $T_R$ ,  $T_F$ ):

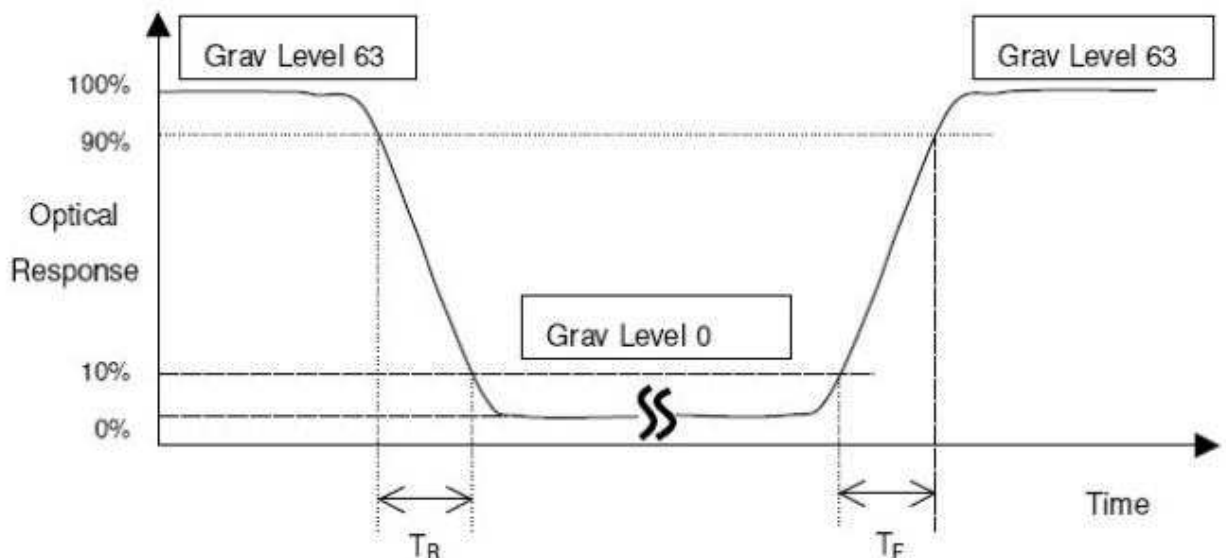

\*Note(3) Definition of Viewing Angle

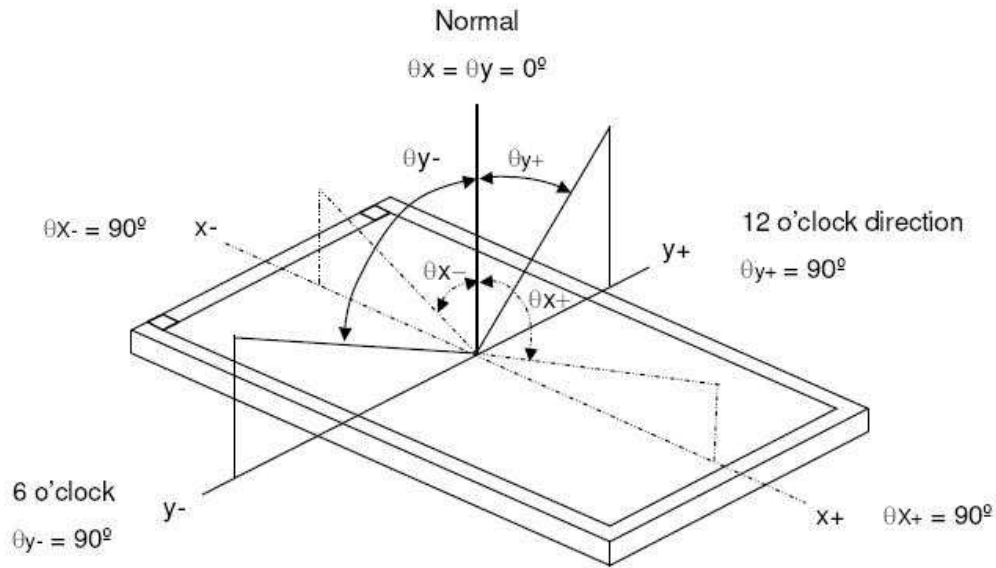

\*Note (4) Measurement Set-Up:

The LCD module should be stabilized at a given temperature for 20 minutes to avoid abrupt temperature change during measuring. In order to stabilize the luminance, the measurement should be executed after lighting Backlight for 20 minutes in a windless room.

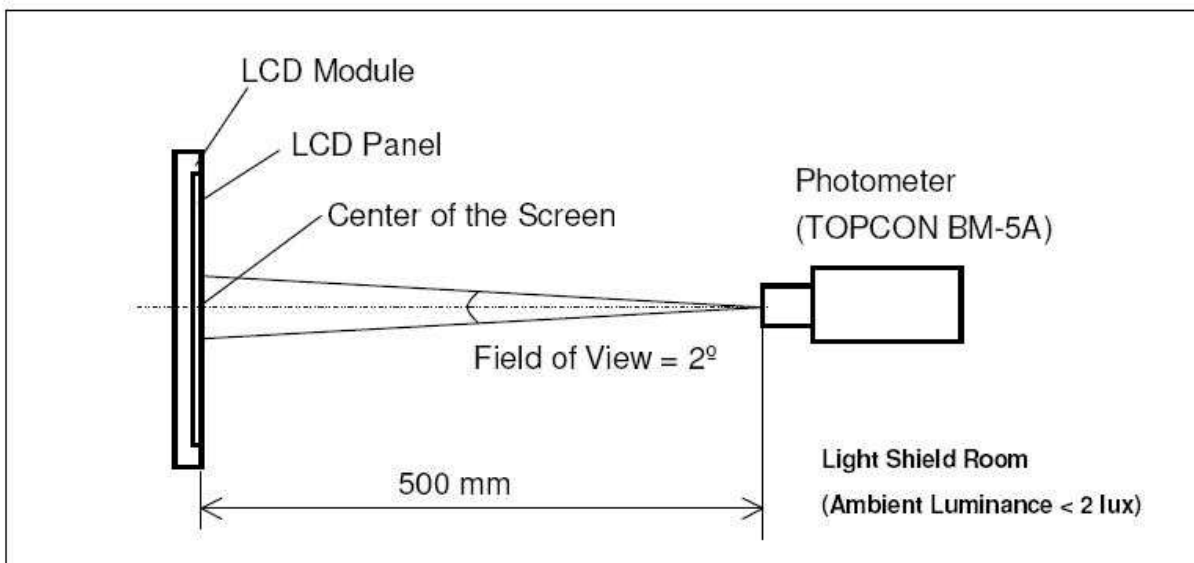

\*Note (5)

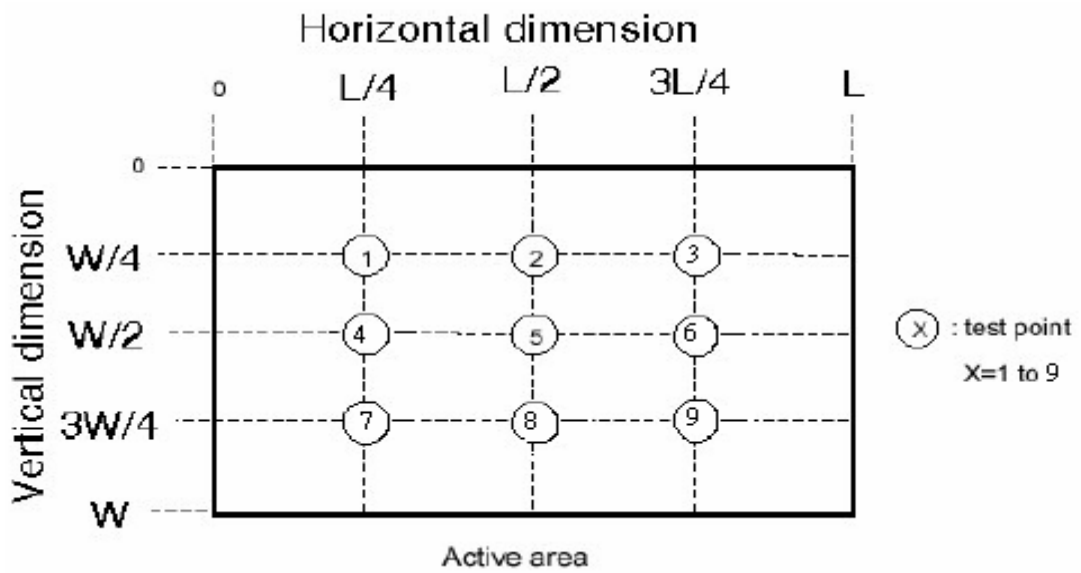

$$\left( 1 - \frac{\text{MAX Luminance} - \text{Average Luminance}}{\text{Average Luminance}} \right) \times 100\% > 70\%$$

# 10. TIMING SPECIFICATIONS

## 10.1 POWER SIGNAL SEQUENCE

### a. Power on:

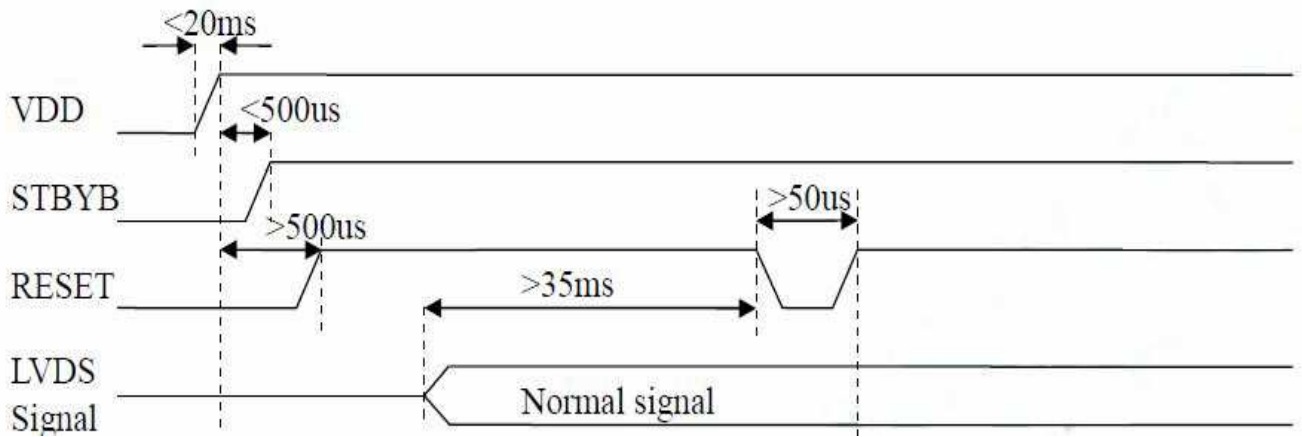

### b. Power off:

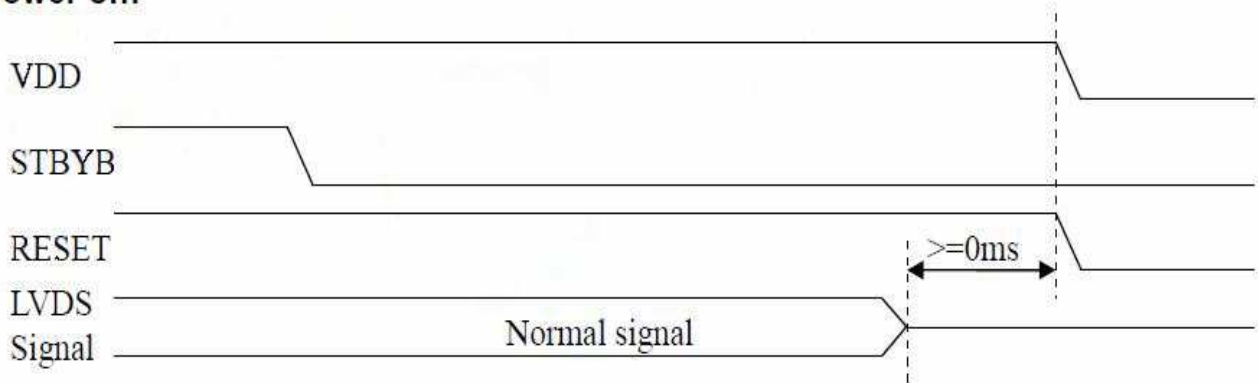

## 10.2 Timing Characteristics of Input Signals

ITEM		SYMBOL	MIN.	TYP.	MAX.	UNIT		
LVDS input signal sequence	CLK Frequency**		clk	40.8	51.2	67.2	MHz	
LCD input signal sequence(Input LVSD Transmitter)	DENA	Horizontal	Horizontal total Time	$t_H$	1114	1344	1400	tCLK
			Horizontal effective Time	$t_{HA}$	1024			tCLK
			Horizontal Blank Time	$t_{HB}$	90	320	376	tCLK
	Vertical	Vertical	Vertical total Time	$t_V$	610	635	800	$t_H$
			Vertical effective Time	$t_{VA}$	600			$t_H$
			Vertical Blank Time	$t_{VB}$	10	35	200	$t_H$

\*\*Frame rate = 60Hz

### 10.3 Timing Sequence(Timing Chart)

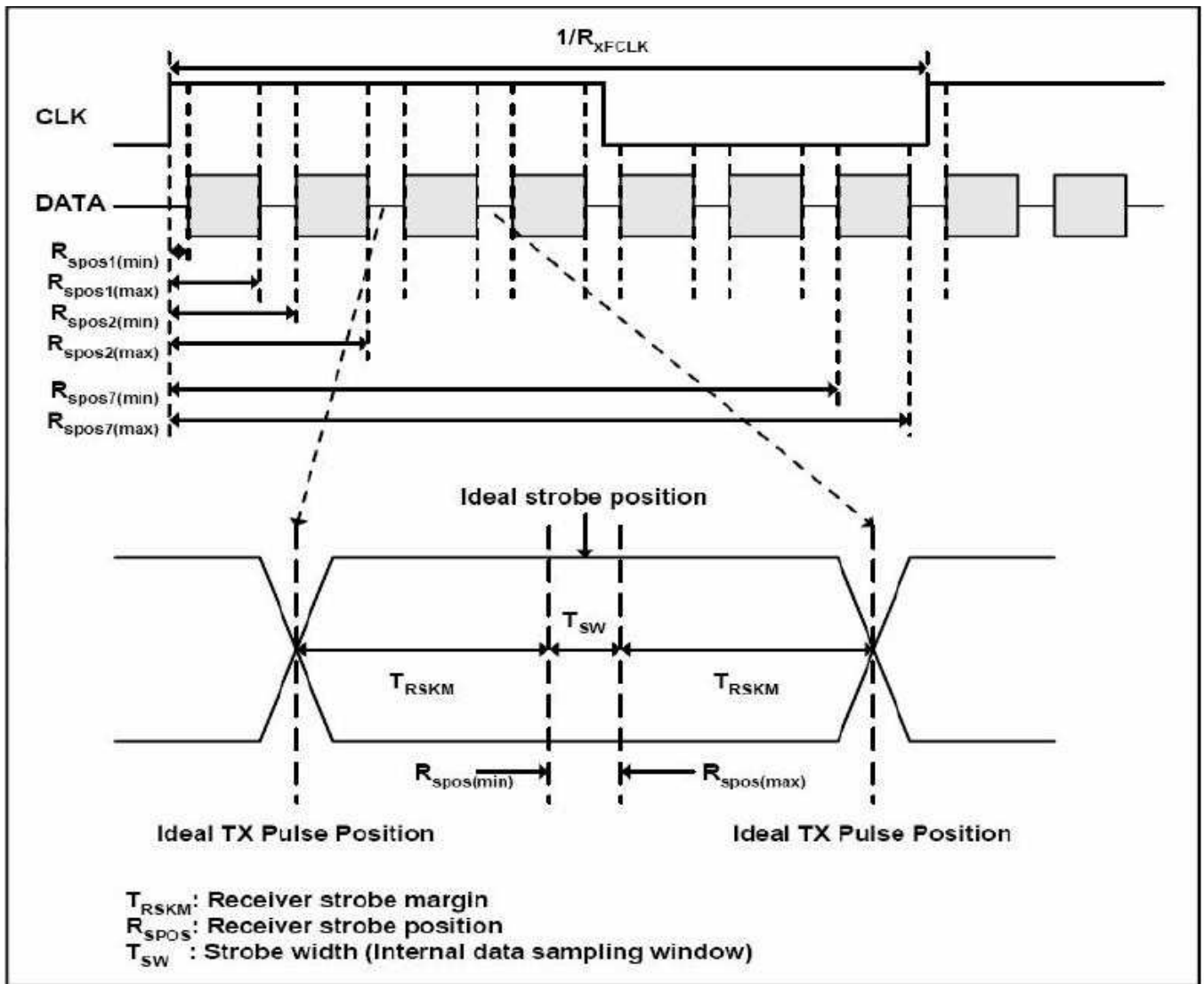
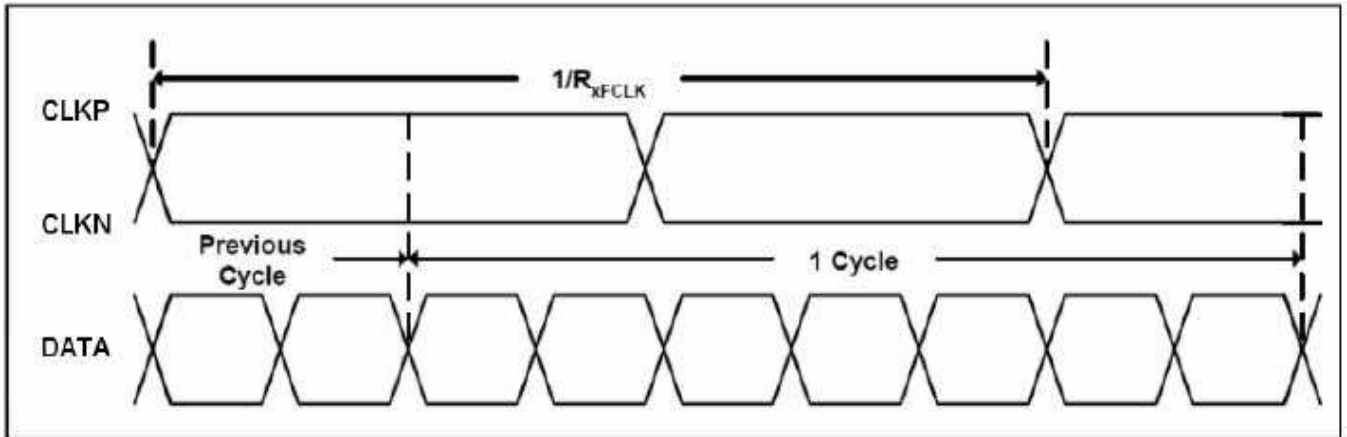

## 10.4 LVDS Input Data Mapping

### 6bit LVDS input

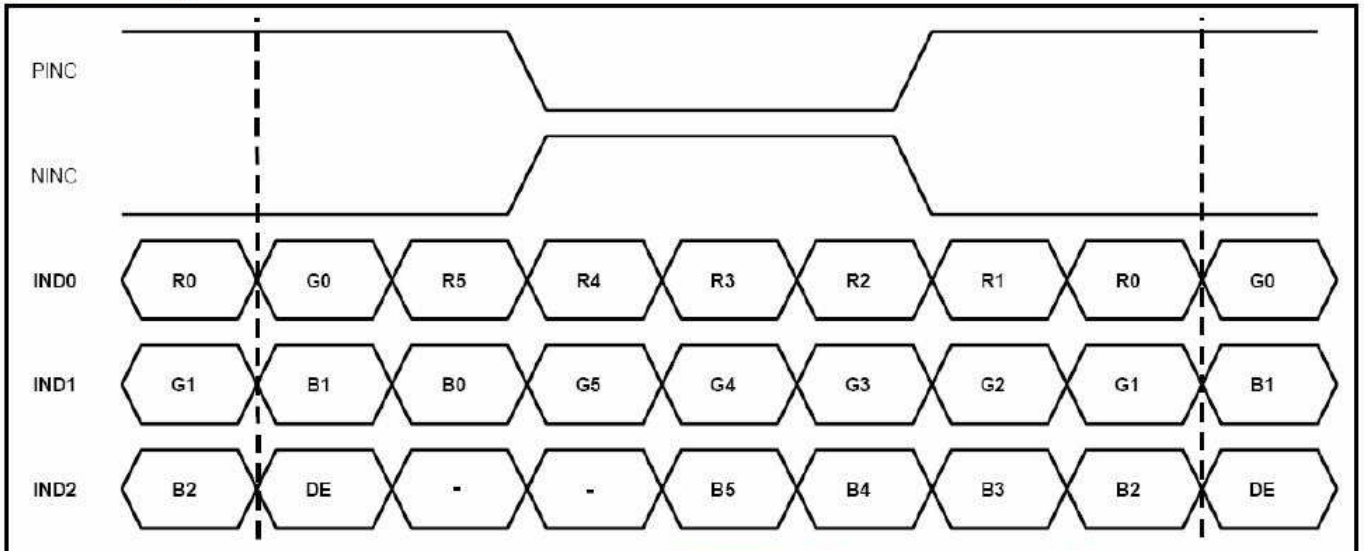

### 8bit LVDS input

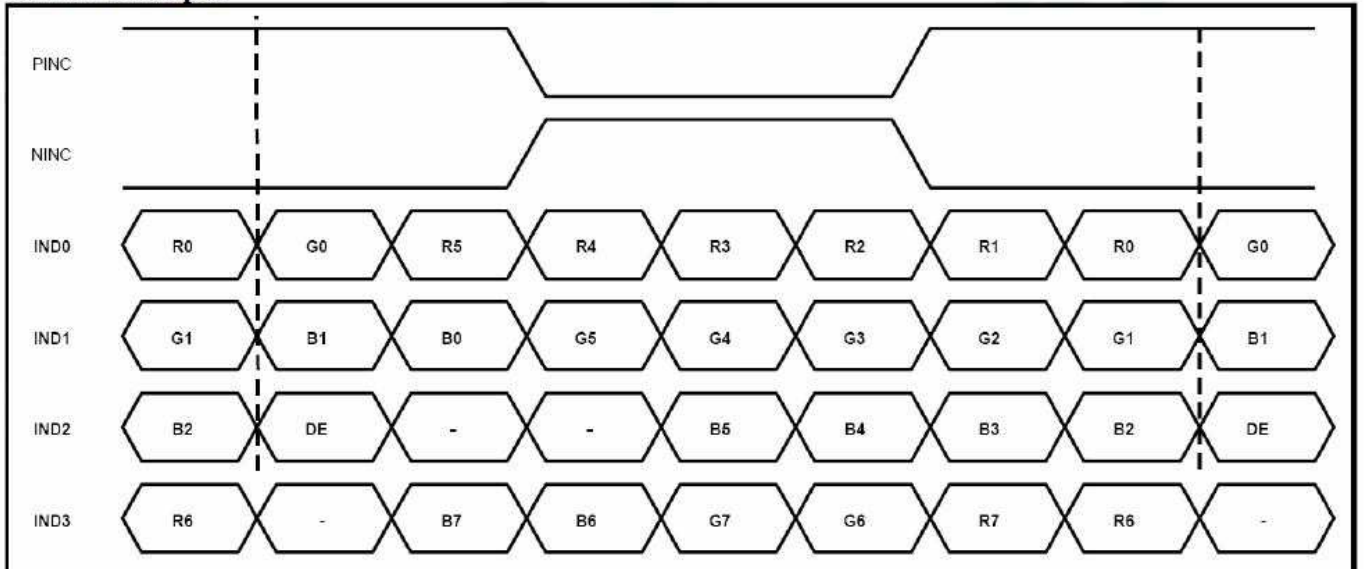

Note: Support DE timing mode only, SYNC mode not supported.



# 11. RELIABILITY TEST

Ta = 25°C

Environmental Test				
NO.	ITEM	CONDITIONS	TIME PERIOD	REMARK
1	High Temperature Storage	80°C	240HRS	
2	Low Temperature Storage	-30±3°C	240HRS	
3	High Temperature Humidity Storage	60°C 90%RH	240HRS	NOTE(2)
4	High Temperature Operation	70°C	240HRS	NOTE(2)
5	Low Temperature Operation	-20°C	240HRS	NOTE(2)
6	Temperature Cycle	-30°C ← 25°C → 80°C (30min) (5min) (30min)	100CYCLE	NOTE(2)

NOTE (1): a. THE MODULE SHOULD WORK PROPERLY.

b. BEFORE AND AFTER FUNCTION TEST, THE DIFFERENCE OF CONSUMPTIVE CURRENT SHOULD BE WITHIN 10%

NOTE (2): a. THE MODULE SHOULD WORK PROPERLY.

b. THE MODLUE WON'T BE DEFORMATIVE, COLOR CHANGEABLE OR BROKEN.

c. THE MODULES CAN'T BE APART.

NOTE (3): BEFORE COSMETIC AND FUNCTION TEST, THE PRODUCT MUST HAVE ENOUGH RECOVERY TIME, AT LEAST 2 HOURS AT ROOM TEMPERATURE.

## 12. PACKAGE METHOD

TBD