



Winstar Display Co., LTD 華凌光電股份有限公司



住址: 407 台中市清江路 163 號
No.163 Chung Ching RD.,
Taichung, Taiwan, R.O.C

WEB: <http://www.winstar.com.tw>
E-mail: winstar@winstar.com.tw
Tel: 886-4-24262208 Fax: 886-4-24262207

SPECIFICATION

Distributed by:



CUSTOMER : _____

MODULE NO.: **WF43GTIBEDBT0#**

未出样, 参数仅供参考

<p>APPROVED BY: (FOR CUSTOMER USE ONLY)</p>	<p>PCB VERSION: DATA:</p>
--	--

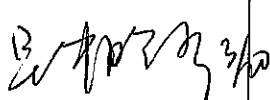
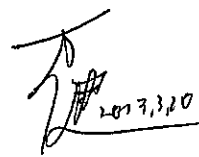
SALES BY	APPROVED BY	CHECKED BY	PREPARED BY
			<p>叶慧芬</p>
<p>ISSUED DATE: 2013-3-18</p>			



MODLE NO :

RECORDS OF REVISION

DOC. FIRST ISSUE

VERSION	DATE	REVISED PAGE NO.	SUMMARY
0	2013.3.18		First issue

Contents

1. Module Classification Information
2. Summry
3. General Specification
4. Absolute Maximum Ratings
5. Electrical Characteristics
6. DC Characteristics
7. Interface Timing
8. Optical Characteristics
9. Interface
10. Block Diagram
11. Reliability
12. Touch panel Information
13. Contour Drawing
14. Package specification
15. Initial Code For Reference

1. Module Classification Information

W F 43 G T I B E D B T 0 #
 ① ② ③ ④ ⑤ ⑥ ⑦ ⑧ ⑨ ⑩ ⑪ ⑫ ⑬

①	Brand : WINSTAR DISPLAY CORPORATION						
②	Display Type : H→Character Type, G→Graphic Type F→TFT Type						
③	Display Size : 4.3 ” TFT						
④	Model serials no.						
⑤	Backlight Type :	F→CCFL, White			T→LED, White		
⑥	LCD Polarize Type/ Temperature range/ Gray Scale Inversion Direction	I→Transmissive, W. T, 6:00 L→Transmissive, W.T,12:00					
⑦	A : TFT LCD B : TFT+FR+CONTROL BOARD C : TFT+FR+A/D BOARD D : TFT+FR+A/D BOARD+CONTROL BOARD E : TFT+FR+POWER BOARD F : TFT+CONTROL BOARD			G : TFT+FR H : TFT+D/V BOARD I : TFT+FR+D/V BOARD J : TFT+POWER BD			
⑧	Solution:						
	A: 128160	B:320234	C:320240	D:480234	E:480272	F: 640480	G: 800480
	H:1024600	I:320480	J:240320	K:800600	L:240400	M :1024768	
⑨	D: Digital L : LVDS						
⑩	Interface : N : without control board A : 8Bit B : 16Bit						
⑪	TS : N : Without TS T : resistive touch panel C : capacitive touch panel						
⑫	Version						
⑬	Special Code	#:Fit in with ROHS directive regulations					



2.SUMMARY

This technical specification applies to 4.3' color TFT-LCD panel. The 4.3' color TFT-LCD panel is designed for camcorder, digital camera application and other electronic products which require high quality flat panel displays. This module follows RoHS.

3.General Specification

Item	Dimension	Unit
Dot Matrix	480 x RGBx272(TFT)	dots
Module dimension	106.7 x 69.6 x 5.9	mm
Active area	95.04 x 53.856	mm
Dot pitch	0.066 x 0.198	mm
LCD type	TFT, Negative, Transmissive	
View Direction	12 o'clock	
Gray Scale Inversion Direction	6 o'clock	
Backlight Type	LED, Normally White	
Controller IC	SSD1963	
Interface	Digital 8080 family MPU	

*Color tone slight changed by temperature and driving voltage.

4.Absolute Maximum Ratings

Item	Symbol	Min	Typ	Max	Unit
Operating Temperature	T_{OP}	-20	—	+70	°C
Storage Temperature	T_{ST}	-30	—	+80	°C

Note: Device is subject to be damaged permanently if stresses beyond those absolute maximum ratings listed above

1. Temp. $\leq 60^{\circ}\text{C}$, 90% RH MAX. Temp. $> 60^{\circ}\text{C}$, Absolute humidity shall be less than 90% RH at 60°C

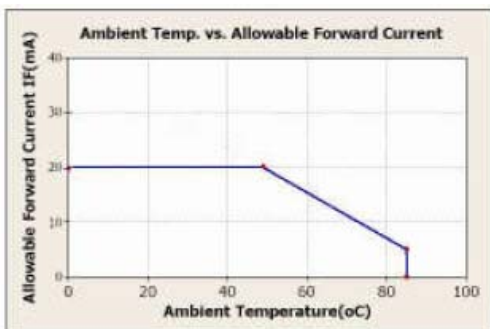

5. Electrical Characteristics

5.1. Operating conditions:

Item	Symbol	Condition	Min	Typ	Max	Unit
Supply Voltage For Logic	VDD	—	3.1	3.3	3.5	V

5.2 LED driving conditions

Parameter	Symbol	Min.	Typ.	Max.	Unit	Remark
LED current		-	20	-	mA	
Power Consumption			640	680	mW	
LED voltage	VBL+	30	32	34	V	Note 1
LED Life Time		-	50,000	-	Hr	Note 2,3,4

Note 1 : There are 1 Groups LED

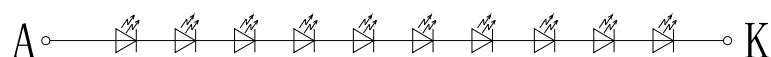

Note 2 : $T_a = 25\text{ }^\circ\text{C}$

Note 3 : Brightness to be decreased to 50% of the initial value

Note 4 : The single LED lamp case

6. DC Characteristics

Parameter	Symbol	Rating			Unit	Condition
		Min	Typ	Max		
Low level input voltage	V_{IL}	0	-	0.3 VDD	V	
High level input voltage	V_{IH}	0.7 VDD	-	VDD	V	

7. Interface Timing

7.1.1 8080 Mode

The 8080 mode MCU interface consist of CS#, D/C#, RD#, WR#, D[23:0] and TE signals (Please refer to Table 6-1 for pin multiplexed with 6800 mode). This interface use WR# to define a write cycle and RD# for read cycle. If the WR# goes low when the CS# signal is low, the data or command will be latched into the system at the rising edge of WR#. Similarly, the read cycle will start when RD# goes low and end at the rising edge of RD#.

7.1.2 8080 Mode Write Cycle

Symbol	Parameter	Min	Typ	Max	Unit
t_{cyc}	Reference Clock Cycle Time	9	-	-	ns
t_{PWCSL}	Pulse width CS# low	1	-	-	t_{cyc}
t_{PWCSH}	Pulse width CS# high	1	-	-	t_{cyc}
t_{FDRD}	First Read Data Delay	5	-	-	t_{cyc}
t_{AS}	Address Setup Time	1	-	-	ns
t_{AH}	Address Hold Time	1	-	-	ns
t_{DSW}	Data Setup Time	4	-	-	ns
t_{DHW}	Data Hold Time	1	-	-	ns
t_{DSR}	Data Access Time	-	-	5	ns
t_{DHR}	Output Hold time	1	-	-	ns

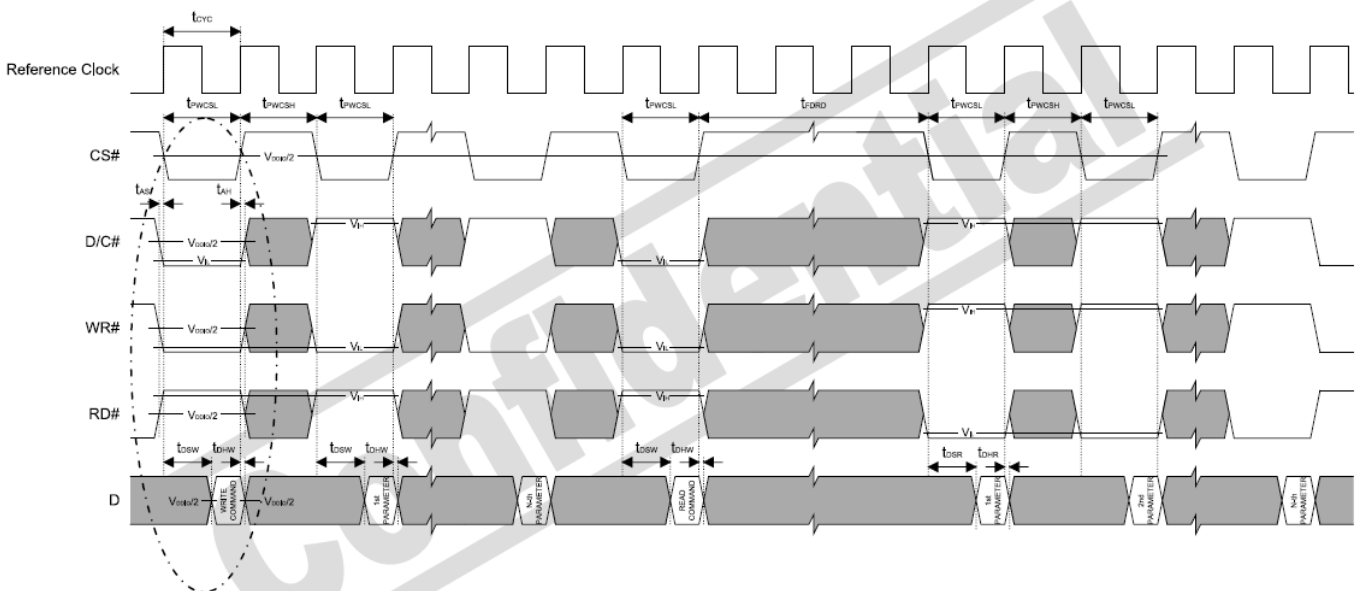

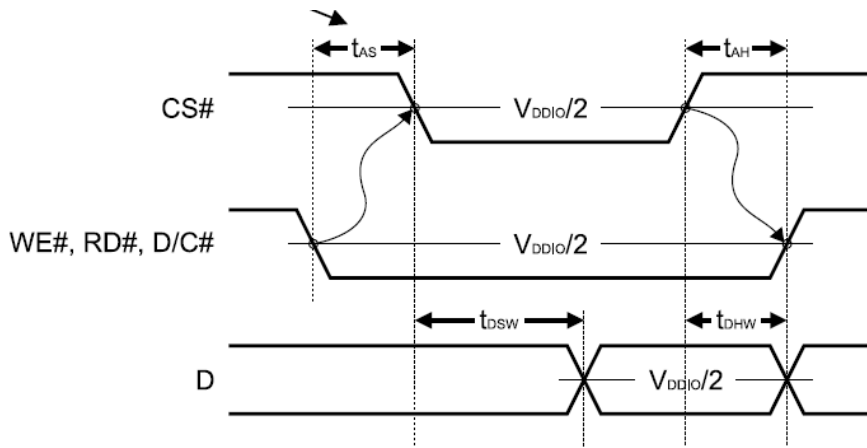

7.1.3 Pixel Data Format

Interface	Cycle	D[23]	D[22]	D[21]	D[20]	D[19]	D[18]	D[17]	D[16]	D[15]	D[14]	D[13]	D[12]	D[11]	D[10]	D[9]	D[8]	D[7]	D[6]	D[5]	D[4]	D[3]	D[2]	D[1]	D[0]	
24 bits	1 st	R7	R6	R5	R4	R3	R2	R1	R0	G7	G6	G5	G4	G3	G2	G1	G0	B7	B6	B5	B4	B3	B2	B1	B0	
18 bits	1 st							R5	R4	R3	R2	R1	R0	G5	G4	G3	G2	G1	G0	B5	B4	B3	B2	B1	B0	
16 bits (565 format)	1 st									R5	R4	R3	R2	R1	G5	G4	G3	G2	G1	G0	B5	B4	B3	B2	B1	
16 bits	1 st									R5	R4	R3	R2	R1	R0	X	X	G5	G4	G3	G2	G1	G0	X	X	
	2 nd									B5	B4	B3	B2	B1	B0	X	X	R5	R4	R3	R2	R1	R0	X	X	
	3 rd									G5	G4	G3	G2	G1	G0	X	X	B5	B4	B3	B2	B1	B0	X	X	
9 bits	1 st																	R5	R4	R3	R2	R1	R0	G5	G4	G3
	2 nd																	G2	G1	G0	B5	B4	B3	B2	B1	B0
8 bits	1 st																	R5	R4	R3	R2	R1	R0	X	X	
	2 nd																	G5	G4	G3	G2	G1	G0	X	X	
	3 rd																	B5	B4	B3	B2	B1	B0	X	X	

X: Don't Care

8. Optical Characteristics

Item	Symbol	Condition.	Min	Typ.	Max.	Unit	Remark
Response time	Tr	$\theta = 0^\circ$ 、 $\Phi = 0^\circ$	-	10	20	.ms	Note 3
	Tf		-	15	30	.ms	
Contrast ratio	CR	At optimized viewing angle	400	500	-	-	Note 4
Color Chromaticity	White	$\theta = 0^\circ$ 、 $\Phi = 0$	Wx	0.24	0.29	0.34	Note 2,5
			Wy	0.26	0.31	0.36	
Viewing angle	Hor.	$CR \geq 10$	ΘR	60	70	Deg.	Note 1
			ΘL	60	70		
	Ver.		ΦT	40	50		
			ΦB	60	70		
Brightness	-	-	240	-	350	cd/m ²	Center of display

Ta=25±2°C, IL=20mA

Note 1: Definition of viewing angle range

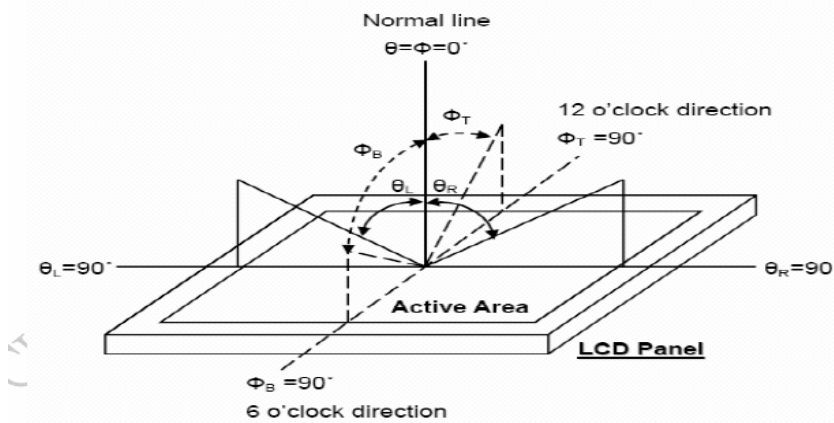

Fig. 8-1 Definition of viewing angle

Note 2: Test equipment setup:

After stabilizing and leaving the panel alone at a driven temperature for 10 minutes, the measurement should be executed. Measurement should be executed in a stable, windless, and dark room. Optical specifications are measured by Topcon BM-7 luminance meter 1.0° field of view at a distance of 50cm and normal direction.

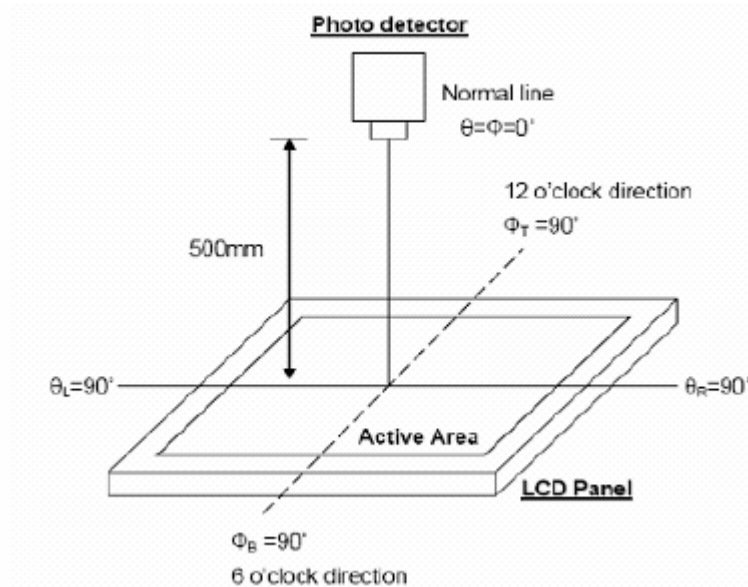

Fig. 8-2 Optical measurement system setup

Note 3: Definition of Response time:

The response time is defined as the LCD optical switching time interval between “White” state and “Black” state. Rise time, T_r , is the time between photo detector output intensity changed from 90% to 10%. And fall time, T_f , is the time between photo detector output intensity changed from 10% to 90%.

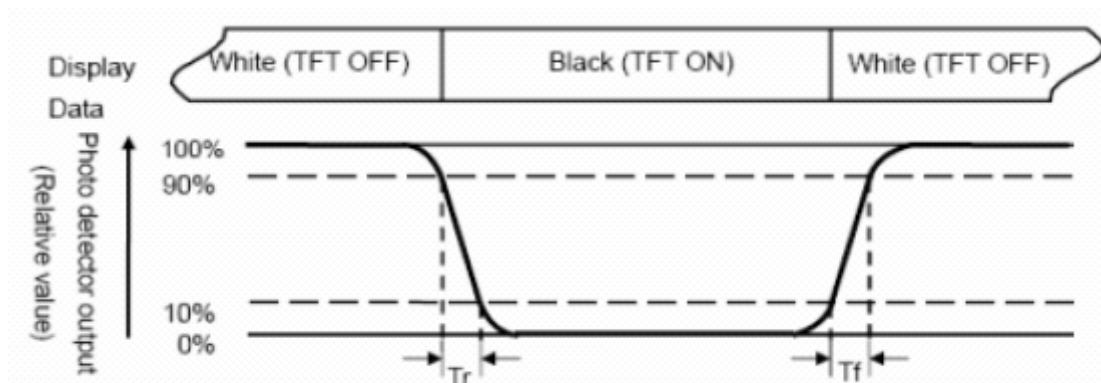

Fig. 3-3 Definition of response time

Note 4: Definition of contrast ratio:

The contrast ratio is defined as the following expression.

$$\text{Contrast ratio (CR)} = \frac{\text{Luminance measured when LCD on the "White" state}}{\text{Luminance measured when LCD on the "Black" state}}$$

Note 5: Definition of color chromaticity (CIE1931)

Color coordinates measured at center point of LCD.

Note 6: All input terminals LCD panel must be ground while measuring the center area of the panel.

9. Interface

9.1. LCM PIN Definition

Pin	Symbol	I/O	Function	Remark
1	GND		System ground pin of the IC. Connect to system ground.	
2	VDD		Power Supply : +3.3V	
3	BL E		Backlight control signal , H: On \ L:Off	
4	D/C		Data/Command select	
5	WR		Write strobe signal	
6	RD		Read strobe signal	
7	D0		Data bus	
8	D1		Data bus	
9	D2		Data bus	
10	D3		Data bus	
11	D4		Data bus	
12	D5		Data bus	
13	D6		Data bus	
14	D7		Data bus	
15	D8		Data bus	
16	D9		Data bus	
17	D10		Data bus	
18	D11		Data bus	
19	D12		Data bus	
20	D13		Data bus	
21	D14		Data bus	
22	D15		Data bus	
23	NC		No connection	
24	NC		No connection	
25	CS		Chip select	
26	RST		Hardware reset	
27	NC		No connection	
28	X1		Right electrode	
29	Y1		Bottom electrode	
30	X2		Left electrode	
31	Y2		Top electrode	
32	DIP ON		Display control H: On \ L:Off	

10. BLOCK DIAGRAM

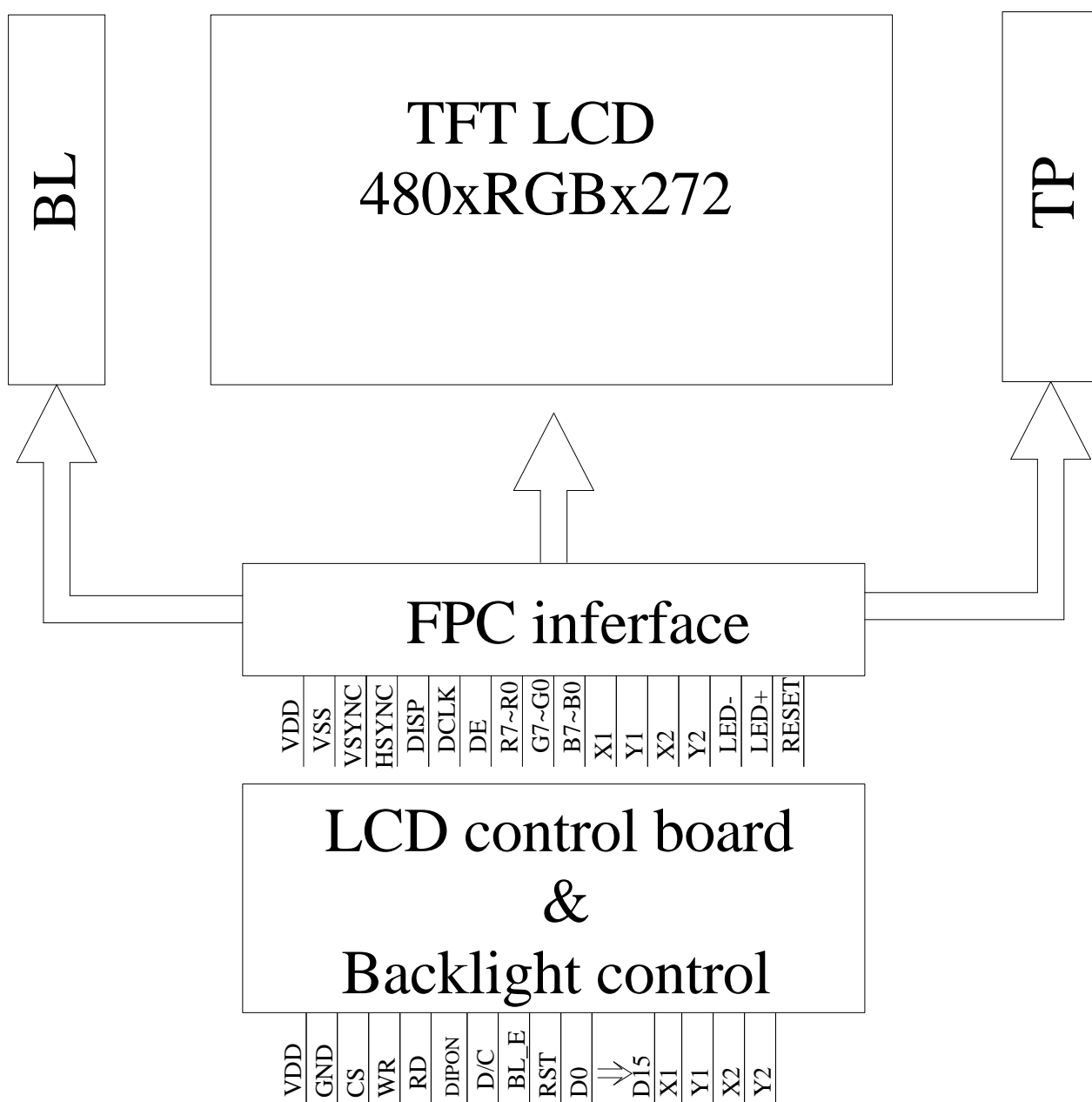

11. Reliability

Content of Reliability Test (Wide temperature, -20°C~70°C)

Environmental Test			
Test Item	Content of Test	Test Condition	Note
High Temperature storage	Endurance test applying the high storage temperature for a long time.	80°C 200hrs	2
Low Temperature storage	Endurance test applying the high storage temperature for a long time.	-30°C 200hrs	1,2
High Temperature Operation	Endurance test applying the electric stress (Voltage & Current) and the thermal stress to the element for a long time.	70°C 200hrs	—
Low Temperature Operation	Endurance test applying the electric stress under low temperature for a long time.	-20°C 200hrs	1
High Temperature/ Humidity Operation	The module should be allowed to stand at 60°C,90%RH max For 96hrs under no-load condition excluding the polarizer, Then taking it out and drying it at normal temperature.	60°C,90%RH 96hrs	1,2
Thermal shock resistance	The sample should be allowed stand the following 10 cycles of operation <div style="text-align: center;"> <p style="margin: 0;">-20°C 25°C 70°C</p> <p style="margin: 0;">←—————→</p> <p style="margin: 0;">30min 5min 30min</p> <p style="margin: 0;">1 cycle</p> </div>	-20°C/70°C 10 cycles	—
Vibration test	Endurance test applying the vibration during transportation and using.	Total fixed amplitude : 3 15mm Vibration Frequency : 10~55Hz One cycle 60 seconds to 3 directions of X,Y,Z for Each 15 minutes	3
Static electricity test	Endurance test applying the electric stress to the terminal.	VS=800V,RS=1.5kΩ CS=100pF 1 time	—

Note1: No dew condensation to be observed.

Note2: The function test shall be conducted after 4 hours storage at the normal Temperature and humidity after remove from the test chamber.

Note3: Vibration test will be conducted to the product itself without putting it in a container.

13. Contour Drawing

PIN	DESC
1	GND
2	VDD
3	BL E
4	D/C
5	WR
6	RD
7	D0
8	D1
9	D2
10	D3
11	D4
12	D5
13	D6
14	D7
15	D8
16	D9
17	D10
18	D11
19	D12
20	D13
21	D14
22	D15
23	NC
24	NC
25	CS
26	RST
27	NC
28	X1
29	Y1
30	X2
31	Y2
32	DIP ON

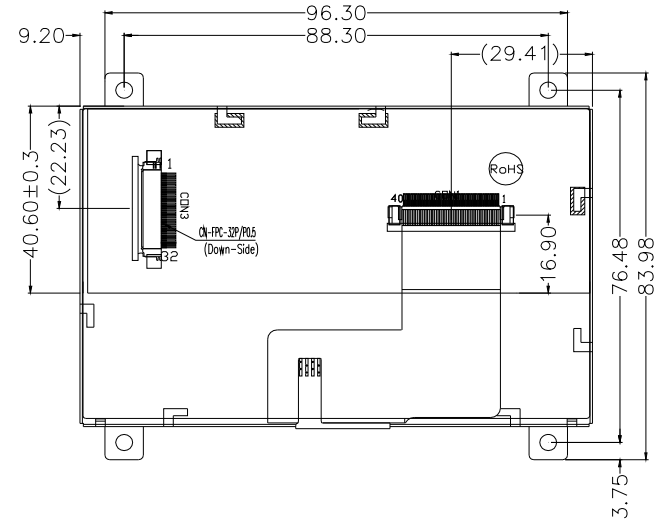
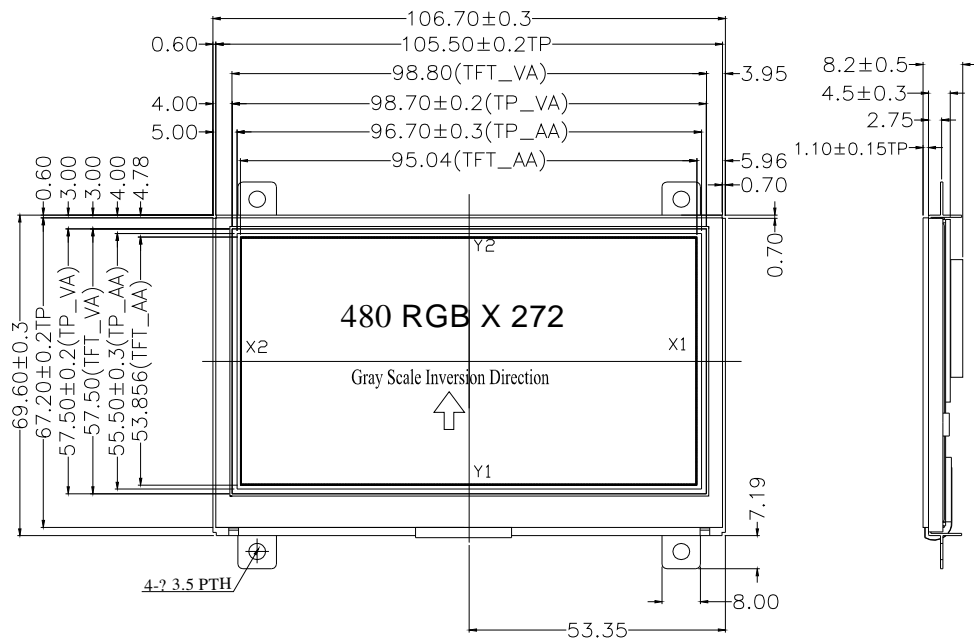

CIRCUIT DIAGRAM(10Dice)

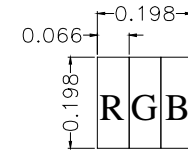
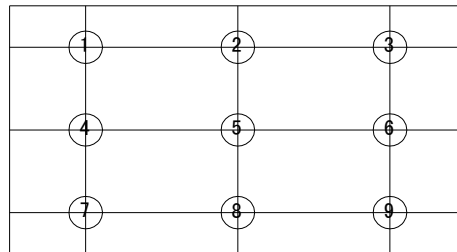

SCALE 1: 100

The non-specified tolerance of dimension is $\pm 0.3\text{mm}$.

14. Package specification

LCM Model	WF43GTIBEDBT0#	LCM 包裝規格書 LCM Packaging Specifications	Approve	Check	Contact
Drawing NO.			DATE	初版	版次 Ver
			12'11/15	12'11/15	0

1. 包裝材料規格表 (Packaging Material) :(per carton)

NO.	Item	Model	Dimensions	Quantity
1	成品 (LCM)	WF43GTIBEDBT0#	TBD	TBD
2	TRAY 盤 (2)	TBD	TBD	TBD
3	BP01 內盒(3)Product Box	PK3R1XXXXXXXXXXXX0001	332 x 280 x 100	TBD
4	泡棉(4)Foam	-----	283 x 230 x 8	TBD
5	外紙箱(5)Carton	PK4Q1XXXXXXXXXXXX0000	565 x 340 x 320	TBD
6				
7				
8				
9				

2. 單箱數量規格表(Packaging Specifications and Quantity) :

(1) LCM quantity per box : no per tray **TBD** x no of tray **TBD** = **TBD**

(2) Total LCM quantity in carton : quantity per box **TBD** x no of boxes **TBD** = **TBD**

特 記 事 項 (REMARK)

1. Label Specifications : <div style="border: 1px solid black; padding: 5px; margin-top: 5px;"> MOOEL: LOT NO : QUANTITY: CHECK: </div>	
--	--

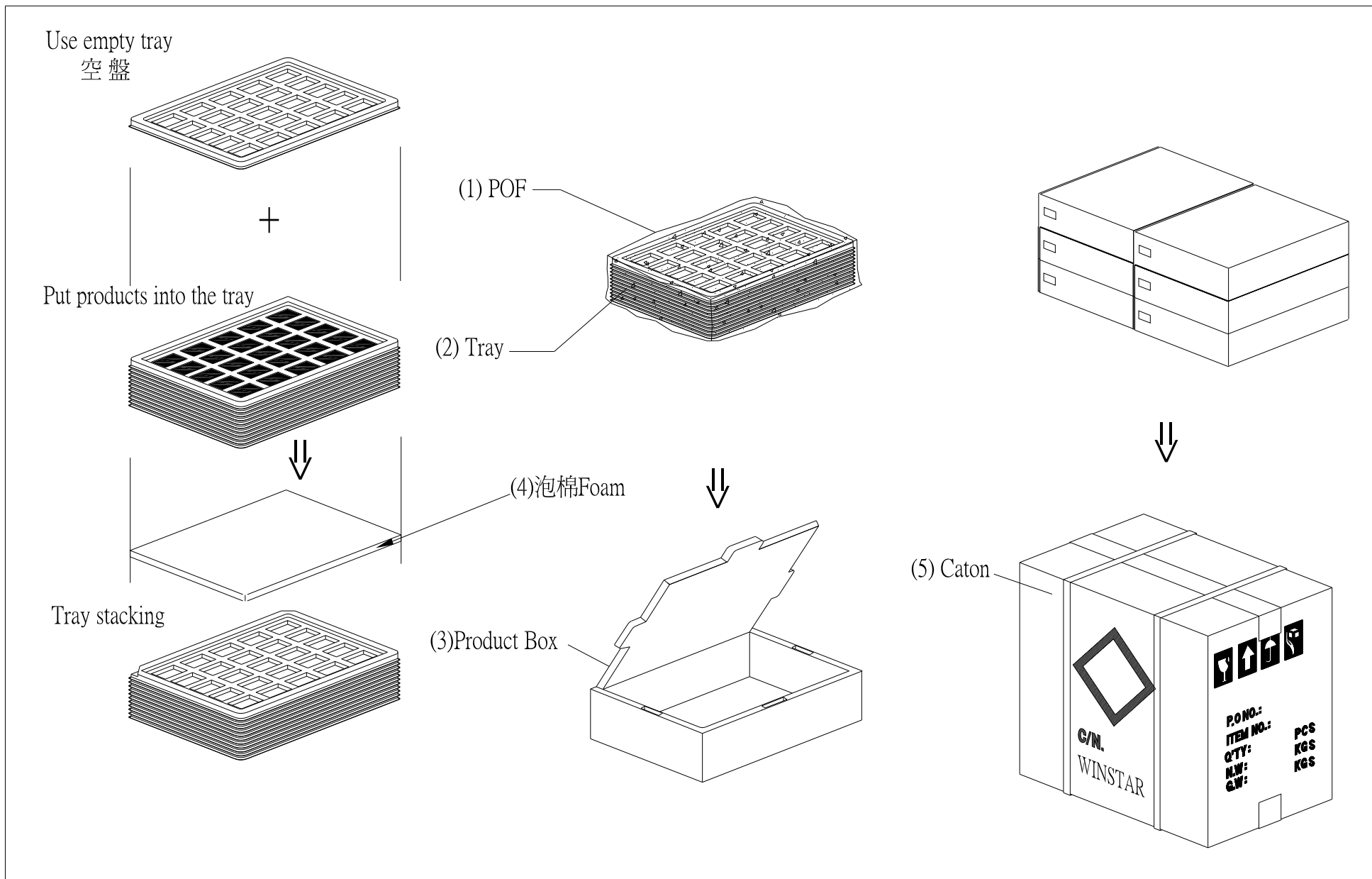

15. Initial Code For Reference

TBD



1、Panel Specification :

- 1. Panel Type : Pass NG , _____
- 2. View Direction : Pass NG , _____
- 3. Numbers of Dots : Pass NG , _____
- 4. View Area : Pass NG , _____
- 5. Active Area : Pass NG , _____
- 6. Operating Temperature : Pass NG , _____
- 7. Storage Temperature : Pass NG , _____
- 8. Others : _____

2、Mechanical Specification :

- 1. PCB Size : Pass NG , _____
- 2. Frame Size : Pass NG , _____
- 3. Material of Frame : Pass NG , _____
- 4. Connector Position : Pass NG , _____
- 5. Fix Hole Position : Pass NG , _____
- 6. Backlight Position : Pass NG , _____
- 7. Thickness of PCB : Pass NG , _____
- 8. Height of Frame to PCB : Pass NG , _____
- 9. Height of Module : Pass NG , _____
- 10. Others : Pass NG , _____

3、Relative Hole Size :

- 1. Pitch of Connector : Pass NG , _____
- 2. Hole size of Connector : Pass NG , _____
- 3. Mounting Hole size : Pass NG , _____
- 4. Mounting Hole Type : Pass NG , _____
- 5. Others : Pass NG , _____

4、Backlight Specification :

- 1. B/L Type : Pass NG , _____
- 2. B/L Color : Pass NG , _____
- 3. B/L Driving Voltage (Reference for LED Type) : Pass NG , _____
- 4. B/L Driving Current : Pass NG , _____
- 5. Brightness of B/L : Pass NG , _____
- 6. B/L Solder Method : Pass NG , _____
- 7. Others : Pass NG , _____

>> **Go to page 2** <<



5、Electronic Characteristics of Module :

- 1. Input Voltage : Pass NG , _____
- 2. Supply Current : Pass NG , _____
- 3. Driving Voltage for LCD : Pass NG , _____
- 4. Contrast for LCD : Pass NG , _____
- 5. B/L Driving Method : Pass NG , _____
- 6. Negative Voltage Output : Pass NG , _____
- 7. Interface Function : Pass NG , _____
- 8. LCD Uniformity : Pass NG , _____
- 9. ESD test : Pass NG , _____
- 10. Others : Pass NG , _____

6、Summary :

Sales signature : _____

Customer Signature : _____

Date : ____ / ____ / ____