



**21.5" Full HD, MVA**  
**High brightness color TFT-LCD module**

**Model: CH215CLKL-HB3**

**Date: Jan. 28<sup>th</sup>, 2013**

**Note: This specification is subject to change  
without notice**

**Customer :** \_\_\_\_\_

**Date :** \_\_\_\_\_

**Approved**

**Prepared**

**Date:**

**Date:**

# Product Specification .

## Contents

- 1. Handling Precautions**
- 2. General Description**
- 3. Functional Block Diagram**
- 4. Absolute Maximum Ratings**
  - 4.1 Absolute Ratings of TFT LCD Module
  - 4.2 Absolute Ratings of Backlight Unit
  - 4.3 Absolute Ratings of Environment
- 5. Electrical characteristics**
  - 5.1 TFT LCD Module
  - 5.2 Backlight Unit
- 6. Signal Characteristic**
  - 6.1 Pixel Format Image
  - 6.2 The Input Data Format
  - 6.4 Interface Timing
  - 6.5 Power ON/OFF Sequence
- 7. Connector & Pin Assignment**
  - 7.1 TFT LCD Module
  - 7.2 Backlight Unit
- 8. Reliability Test**
- 9. Shipping Label**
- 10. Mechanical Characteristic**

# Product Specification .

## RECORD OF REVISION

Version and Date	Page	Old description	New description	Remark
0.1 2013/01/28	All	First Edition for customer		

# Product Specification .

## 1. HANDLING PRECAUTIONS

- 1) Since front polarizer is easily damaged, pay attention not to scratch it.
- 2) Be sure to turn off power supply when inserting or disconnecting from input connector.
- 3) Wipe off water drop immediately. Long contact with water may cause discoloration or spots.
- 4) When the panel surface is soiled, wipe it with absorbent cotton or other soft cloth.
- 5) Since the panel is made of glass, it may break or crack if dropped or bumped on hard surface.
- 6) Since CMOS LSI is used in this module, take care of static electricity and insure human earth when handling.
- 7) Do not open or modify the Module Assembly.
- 8) Do not press the reflector sheet at the back of the module to any directions.
- 9) At the insertion or removal of the Signal Interface Connector, be sure not to rotate nor tilt the Interface Connector of the TFT Module.
- 10) After installation of the TFT Module into an enclosure, do not twist nor bend the TFT Module even momentary. At designing the enclosure, it should be taken into consideration that no bending/twisting forces are applied to the TFT Module from outside. Otherwise the TFT Module may be damaged.

# Product Specification .

## 2. General Description

### 2.1, Overview

This specification applies to the 21.5 inch-FHD Color a-Si TFT-LCD. The display supports the FHD - 1920(H) x 1080(V) screen format and 16.7M colors (RGB 8-bits data). The light source of this TFT-LCD module is W-LED. All input signals are 2-channel LVDS interface and this module doesn't contain a driver for backlight.

### 2.2 Features

- Sunlight readable display, 800nits.
- LED backlight by long operation life design
- WUXGA (1920x1080 pixels) full HD resolution
- RoHS Compliance

### 2.3 Application

Industrial Application; especial for outdoor kiosk and digital signage display.

# Product Specification .

## 2.4 Display Specifications

Items	Unit	Specification
Screen Diagonal	mm	546.865 (21.53")
Active Area	mm	476.64(H) x 268.11(V)
Pixels H x V	pixels	1920(x3) x 1080
Pixels Pitch	um	248.25(per one triad) x 248.25
Pixel Arrangement		RGB Vertical stripe
Display mode		VA mode, normally black
White luminance (center)	Cd/m <sup>2</sup>	800 (Typ., TBD)
Contrast ratio		3,000 (Typ.)
Optical Response Time	msec	25 ms (Typ. on/off)
Normal Input Voltage VDD	Volt	5
Power Consumption (VDD Line + LED lines)	Watt	34 (Typ. TBD) (all black pattern, VDD=4.0W, LED= 29.7)
Weight	Grams	1800 (Typ.)
Physical size	mm	495.6 x 292.2 x10.6 (Typ.)
Electrical Interface		Dual Chanel LVDS
Support Colors		16.7 M colors (RGB 8-bit)
Surface Treatment		Anti-Glare, 3H
Temperature range		
Operating	°C	-10 ~ 50
Storage (Shipping)	°C	-20 ~ 60
RoHS Compliance		RoHS Compliance
TCO Compliance		TCO 5.1 Compliance

# Product Specification .

## 2.5 Optical Characteristics

The following optical characteristics are measured under stable condition at 25 °C

Items	Unit	Conditions	Min.	Typ.	Max.	Note
Viewing angle	Deg.	Horizontal (Right) CR=10 (Left)	150	178		2
		Vertical (Up) CR=10 (Down)	150	178		
Contrast Ratio		Normal Direction	1500	3000		3
Response Time	msec	Raising time (T <sub>IR</sub> )		TBD		4
		Falling time (T <sub>IF</sub> )		TBD		
		Raising + Falling		25	35	
Color / Chromaticity Coordinates (CIE)		Red x	Typ -0.03	0.64	Typ +0.03	5
		Red y		0.33		
		Green x		0.31		
		Green y		0.64		
		Blue x		0.15		
		Blue y		0.05		
Color coordinates (CIE) White		White x		0.310		
		White y		0.350		
Center Luminance	Cd/m <sup>2</sup>		700	800		6
Luminance Uniformity	%		60	70		7
Crosstalk (in 60 Hz)	%				TBD	
Flicker	dB				TBD	

# Product Specification .

## Note 1: Measurement method

The LCD module should be stabilized at given temperature for 0.5 hour to avoid abrupt temperature change during measuring. In order to stabilize the luminance, the measurement should be executed after lighting Backlight for 1 hour in a windless room.

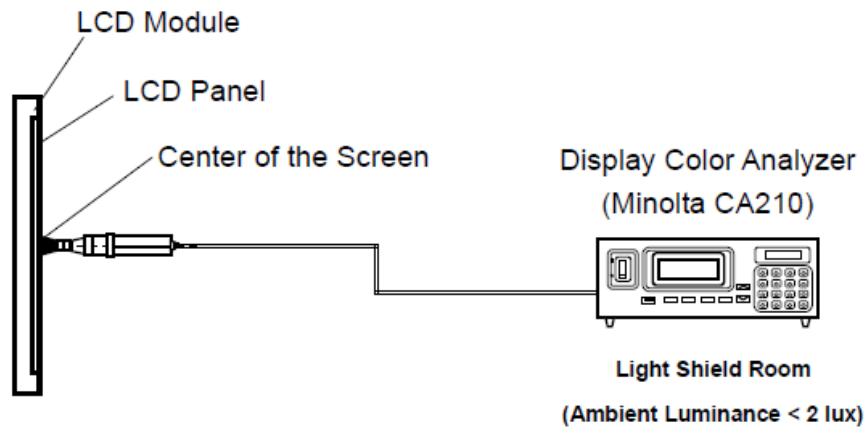

## Note 2: Definition of viewing angle

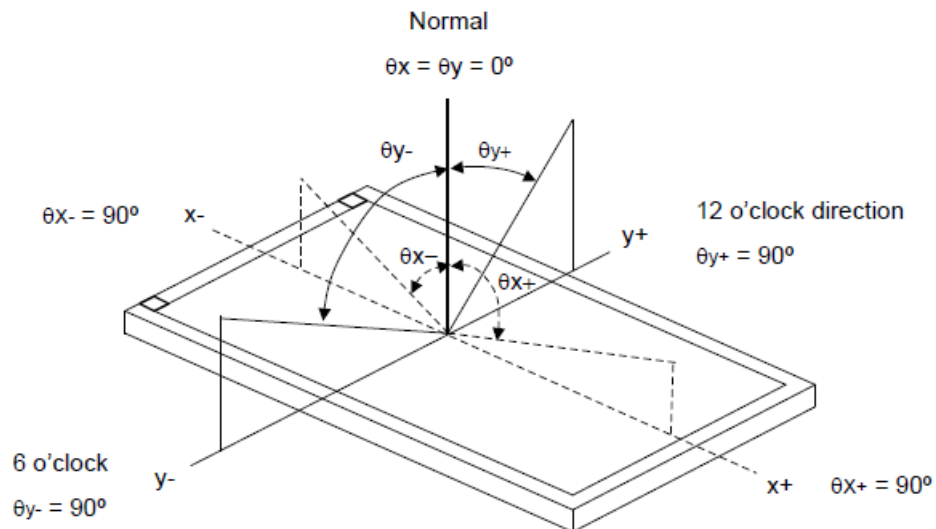

## Note 3: Contrast ratio is measured by Minolta CA210



# Product Specification .

## Note 4: Definition of Response time

The output signals of photo detector are measured when the input signals are changed from "Full Black" to "Full White" (rising time), and from "Full White" to "Full Black" (falling time), respectively. The response time is interval between the 10% and 90% of amplitudes. Please refer to the figure as below.

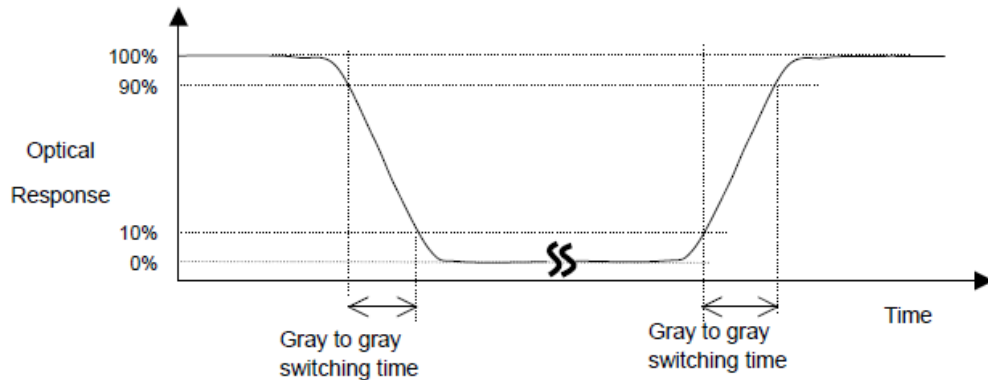

Note 5: Color chromaticity and coordinates (CIE) is measured by Minolta CA210

Note 6: Center luminance is measured by Minolta CA210

Note 7: Luminance uniformity of these 5 points is defined as below and measured by Minolta CA210

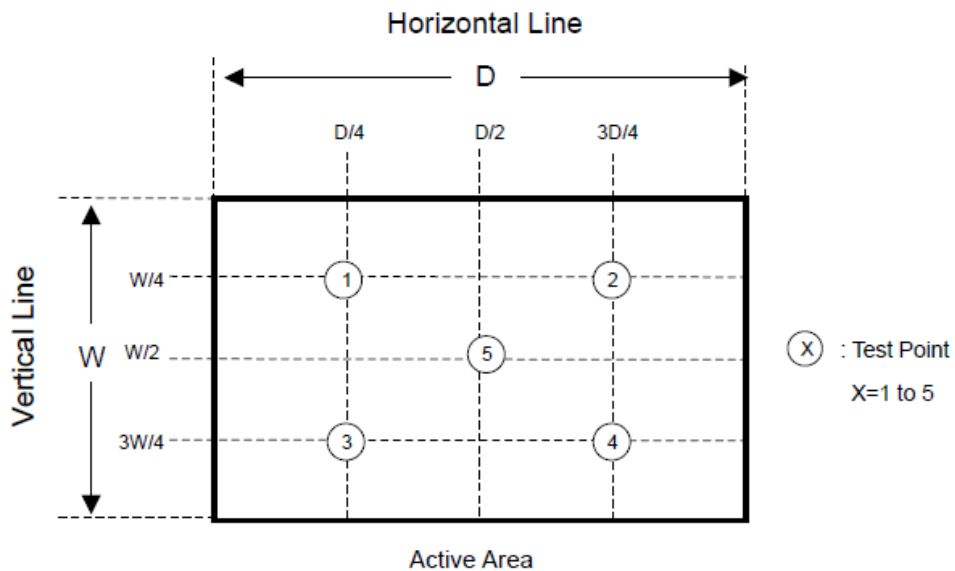

$$\text{Uniformity} = (\text{Min. Luminance of 5 points}) / (\text{Max. Luminance of 5 points})$$

# Product Specification .

## 3. Functional Block Diagram

The following diagram shows the functional block of the 21.5 inches Color TFT-LCD Module:

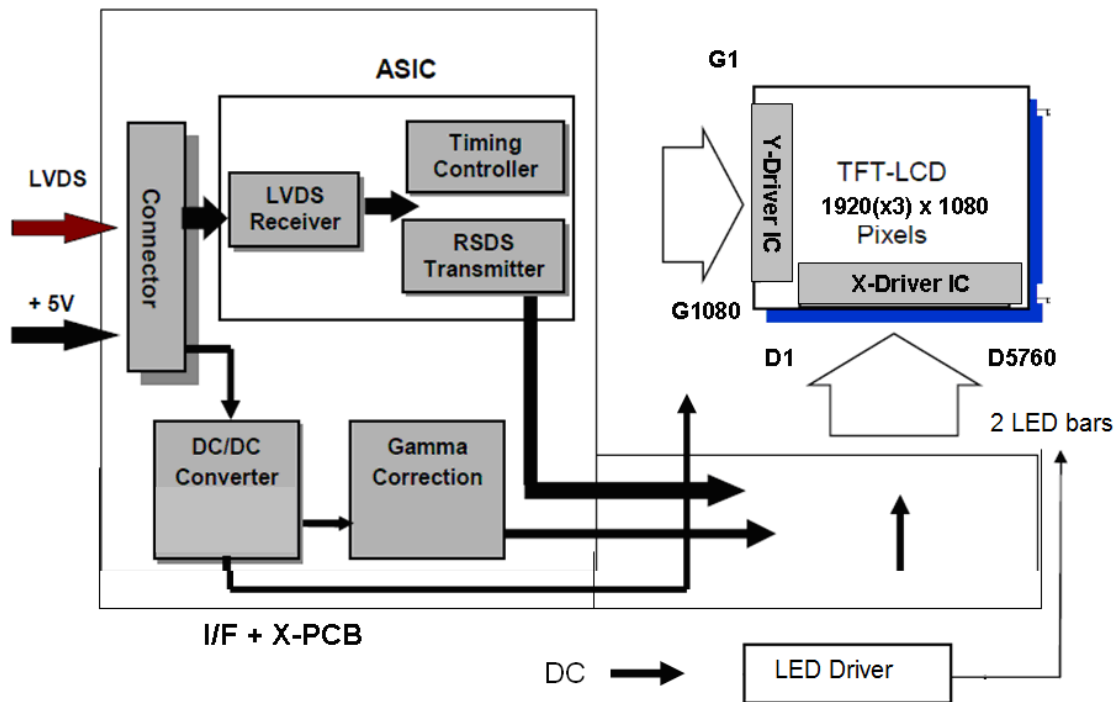

I/F PCB Interface:

MSCKT2407P30HB

AL230F-A0G1D-P

Mating Type:

FI-X30HL(Locked Type)

# Product Specification .

## 4. Absolute Maximum Ratings

Absolute maximum ratings of the module are as following:

### 4.1 TFT LCD Module

Items	Symbol	Min	Max	Unit	Conditions
Logic/ LCD drive voltage	VDD	0	5.5	Volt	Note 1, 2

### 4.2 Backlight unit

Items	Symbol	Min	Max	Unit	Conditions
LED Current	I LED		600	mA	Note 1, 2

### 4.3 Absolute Ratings of Environment

Items	Symbol	Values			Unit	Conditions
		Min.	Typ.	Max.		
Operation temperature	T <sub>OP</sub>	-10	-	50	°C	Note 3
Operation Humidity	H <sub>OP</sub>	5		90	%	
Storage temperature	T <sub>ST</sub>	-20		60	°C	
Storage Humidity	H <sub>ST</sub>	5		90	%	

Note 1: With in Ta= 25°C

Note 2: Permanent damage to the device may occur if exceed maximum values

Note 3: For quality performance, please refer to IIS (Incoming Inspection Standard).

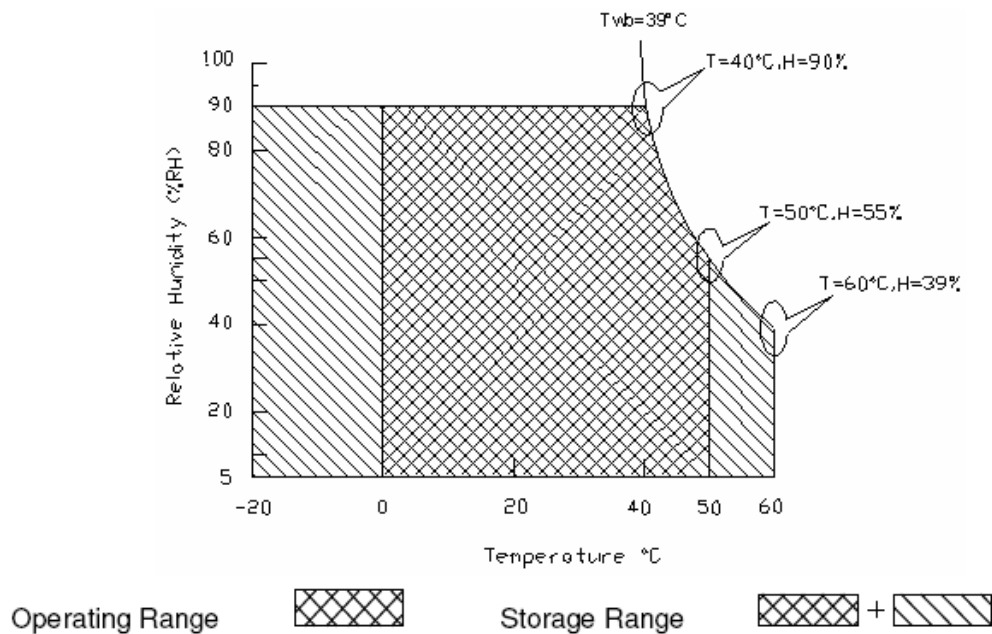

# Product Specification .

## 5. Electrical characteristics

### 5.1 TFT LCD Module

#### 5.1.1 Power Specification

Input power specifications are as follows

Symbol	Parameter	Min	Typ.	Max	Unit	Conditions
VDD	Logic/ LCD Drive Voltage	4.5	5	5.5	Volt	+/- 10%
IDD	Input current		0.8	0.96	A	VDD=5V, All black pattern. At 75Hz, +30%
PDD	VDD power		4.0	4.8	W	VDD=5V, All black pattern. At 75Hz,
IRush	Inrush current			3	A	Note 1
VDDrp	Allowable Logic/LCD Drive Ripple Voltage			500	mV p-p	VDD=5V, All black pattern. At 75Hz,

Note 1: Measurement conditions:

The duration of rising time of input power is 470 us.

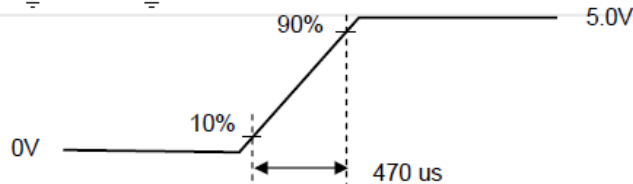
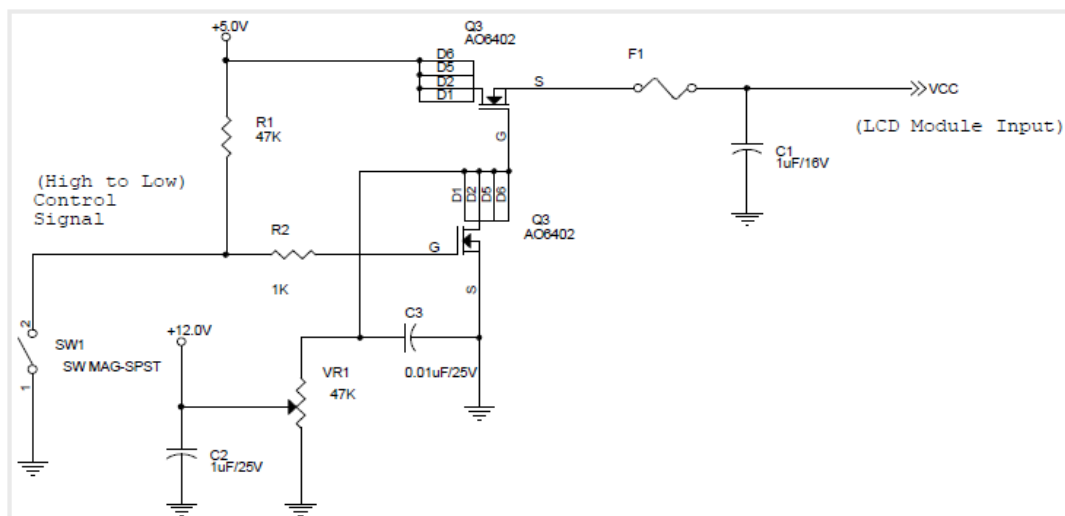

Vin rising time

# Product Specification .

## 5.1.2 Signal Electrical Characteristics

Input signal shall be low or Hi-Z state when VDD is off. Please refer to specification of SN75LVDS82DGG (Texas Instruments) in detail.

Characteristics of each signal are as following:

Symbol	Parameter	Min	Typ	Max	Unit	Condition
V <sub>TH</sub>	Differential Input High Threshold		+50	+100	mV	V <sub>ICM</sub> = 1.2V NOTE 1
V <sub>TL</sub>	Differential Input Low Threshold	-100	-50		mV	V <sub>ICM</sub> = 1.2V NOTE 1
V <sub>ID</sub>	Input Differential Voltage	100		600	mV	NOTE 1
V <sub>ICM</sub>	Differential Input Common Mode Voltage	+1.0	+1.2	+1.5	V	V <sub>TH</sub> -V <sub>TL</sub> = 200mV(MAX) NOTE 1

Note 1: LVDS Signal Waveform

Single-End

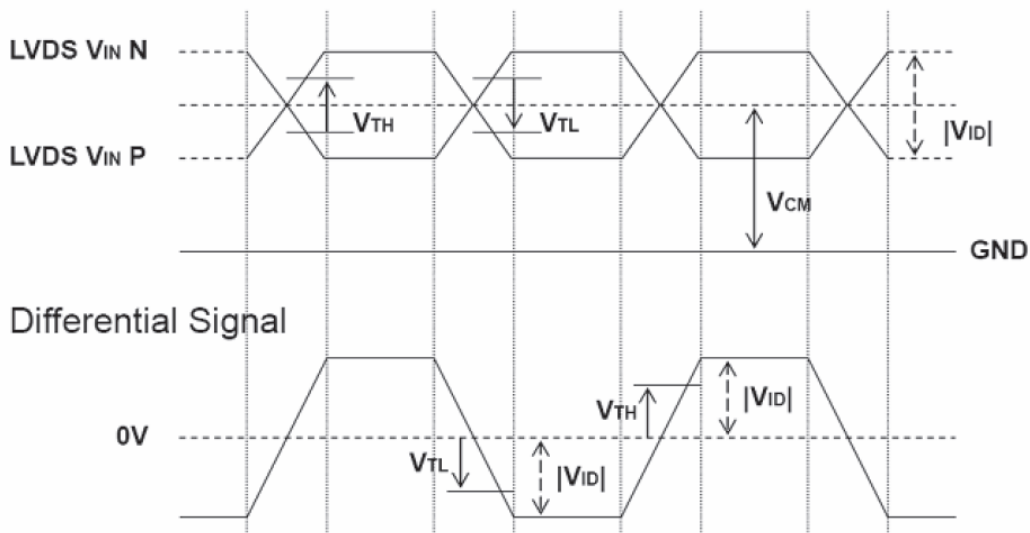

# Product Specification .

## (2) AC Characteristics

Symbol	Description	Min	Max	Units	Conditions
$F_{DEV}$	Maximum deviation of input clock frequency during SSC	-	$\pm 3$	%	
$F_{MOD}$	Maximum modulation frequency of input clock during SSC	-	200	KHz	

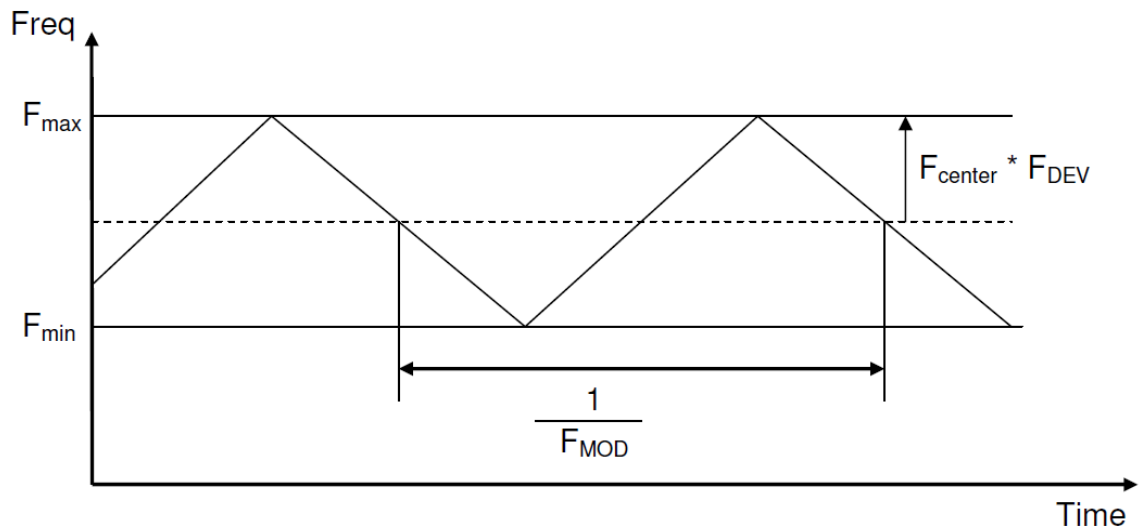

< Spread Spectrum >

# Product Specification .

## 5.2 Backlight Unit

Parameter guideline is under stable conditions at 25°C (Room Temperature):

Parameter	Min	Typ	Max	Unit	Note
LED voltage (VL)		29.7		[V]	
LED current (IL)		500		[mA]	,
LED power consumption		29.7		W	2
LED Life Time(LTLED)		40,000		[Hour]	1

Note 1: The “LED lift time” is defined as the module brightness decrease to 50% original brightness that the ambient temperature is 25°C and typical LED Current at 500 mA .

Note 2: Power consumption is VL x IL x 2 (2 LED bards)

# Product Specification .

## 6. Signal Characteristic

### 6.1 Pixel Format Image

Following figure shows the relationship of the input signals and LCD pixel format.

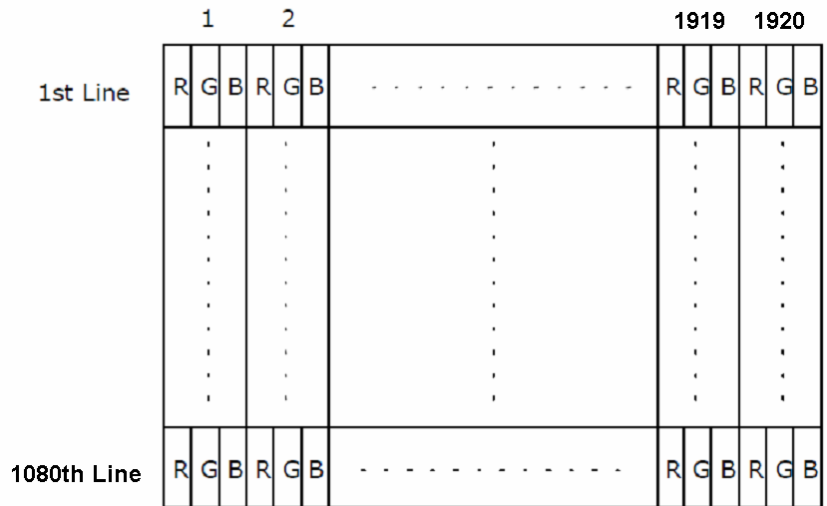

### 6.2 The Input Data Format

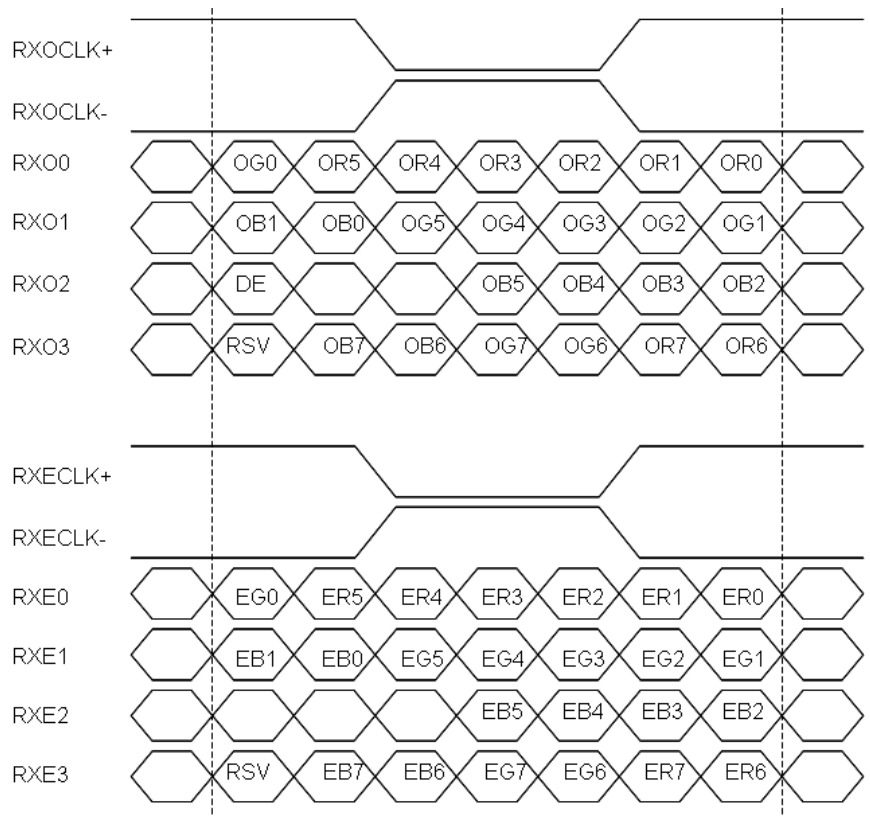

Note 1: R/G/B data 7:MSB, R/G/B data 0:LSB "O"="First Pixel Data"  
 "E"="Second Pixel Data"



# Product Specification .

## 6.3 Signal Description

The module using one LVDS receiver SN75LVDS82(Texas Instruments). LVDS is a differential signal technology for LCD interface and high speed data transfer device.

Transmitter shall be SN75LVDS83(negative edge sampling). The first LVDS port(RxOxxx) transmits odd pixels while the second LVDS port(RxExxx) transmits even pixels.

PIN#	Signal Name	DESCRIPTION
1	RxOIN0-	Negative LVDS differential data input (Odd data)
2	RxOIN0+	Positive LVDS differential data input (Odd data)
3	RxOIN1-	Negative LVDS differential data input (Odd data)
4	RxOIN1+	Positive LVDS differential data input (Odd data)
5	RxOIN2-	Negative LVDS differential data input (Odd data, DSPTMG)
6	RxOIN2+	Positive LVDS differential data input (Odd data, DSPTMG)
7	GND	Power Ground
8	RxOCLK-	Negative LVDS differential clock input (Odd clock)
9	RxOCLK+	Positive LVDS differential clock input (Odd clock)
10	RxOIN3-	Negative LVDS differential data input (Odd data)
11	RxOIN3+	Positive LVDS differential data input (Odd data)
12	RxEIN0-	Negative LVDS differential data input (Even data)
13	RxEIN0+	Positive LVDS differential data input (Even data)
14	GND	Power Ground
15	RxEIN1-	Negative LVDS differential data input (Even data)
16	RxEIN1+	Positive LVDS differential data input (Even data)
17	GND	Power Ground
18	RxEIN2-	Negative LVDS differential data input (Even data)
19	RxEIN2+	Positive LVDS differential data input (Even data)
20	RxECLK-	Negative LVDS differential clock input (Even clock)
21	RxECLK+	Positive LVDS differential clock input (Even clock)
22	RxEIN3-	Negative LVDS differential data input (Even data)
23	RxEIN3+	Positive LVDS differential data input (Even data)
24	GND	Power Ground
25	NC	Do not connect ( for test only)
26	NC	Do not connect ( for test only)
27	NC	Do not connect ( for test only)
28	VDD	Power +5V
29	VDD	Power +5V
30	VDD	Power +5V

# Product Specification .

Note 1: Start from left side

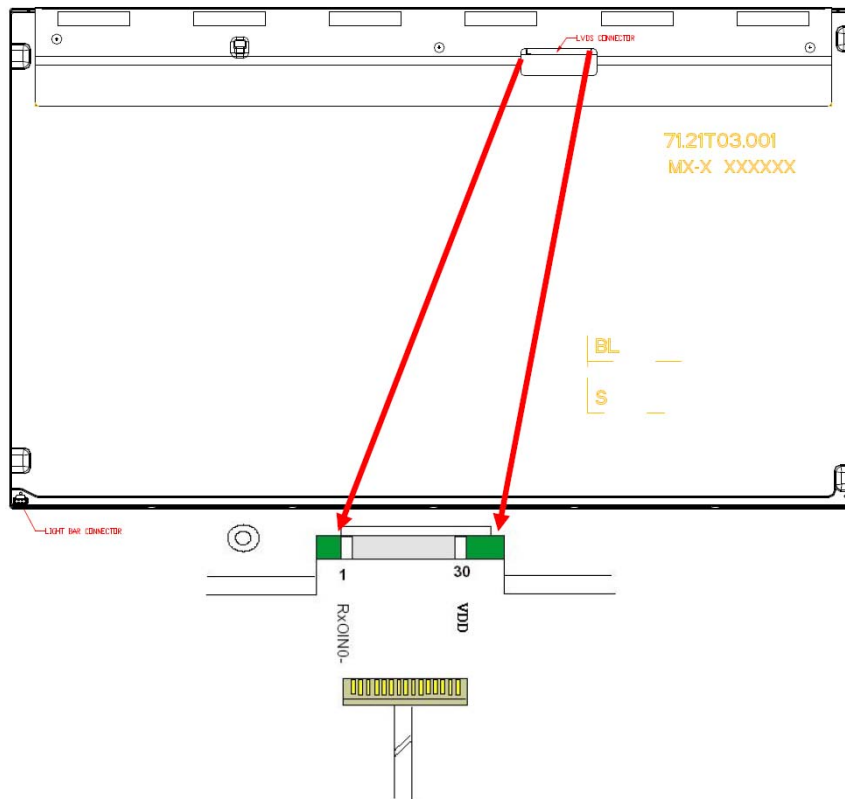

Note2: Input signals of odd and even clock shall be the same timing.

## 6.4. Timing Characteristics

The input signal timing specifications are shown as the following table.

Items		Symbol	Min.	Typ.	Max.	Unit
Clock	Period	Tclk	25	13.89	11.11	ns
	Frequency	Freq	40	72	90	MHz
H-section	Period	Th	1004	1050	2047	Tclk
	Display Area	Tdisp(h)	960	960	960	Tclk
	Blanking	Tbp(h)+Tfp(h)+PWhs	44	90	1087	Tclk
V-section	Period	Tv	1088	1130	2047	Th
	Display Area	Tdisp(v)	1080	1080	1080	Th
	Blanking	Tbp(v)+Tfp(v)+PWvs	8	50	967	Th
Frame Rate		F	50	60	75	Hz

Note: DE mode only

# Product Specification .

## 6.5 Timing Diagram

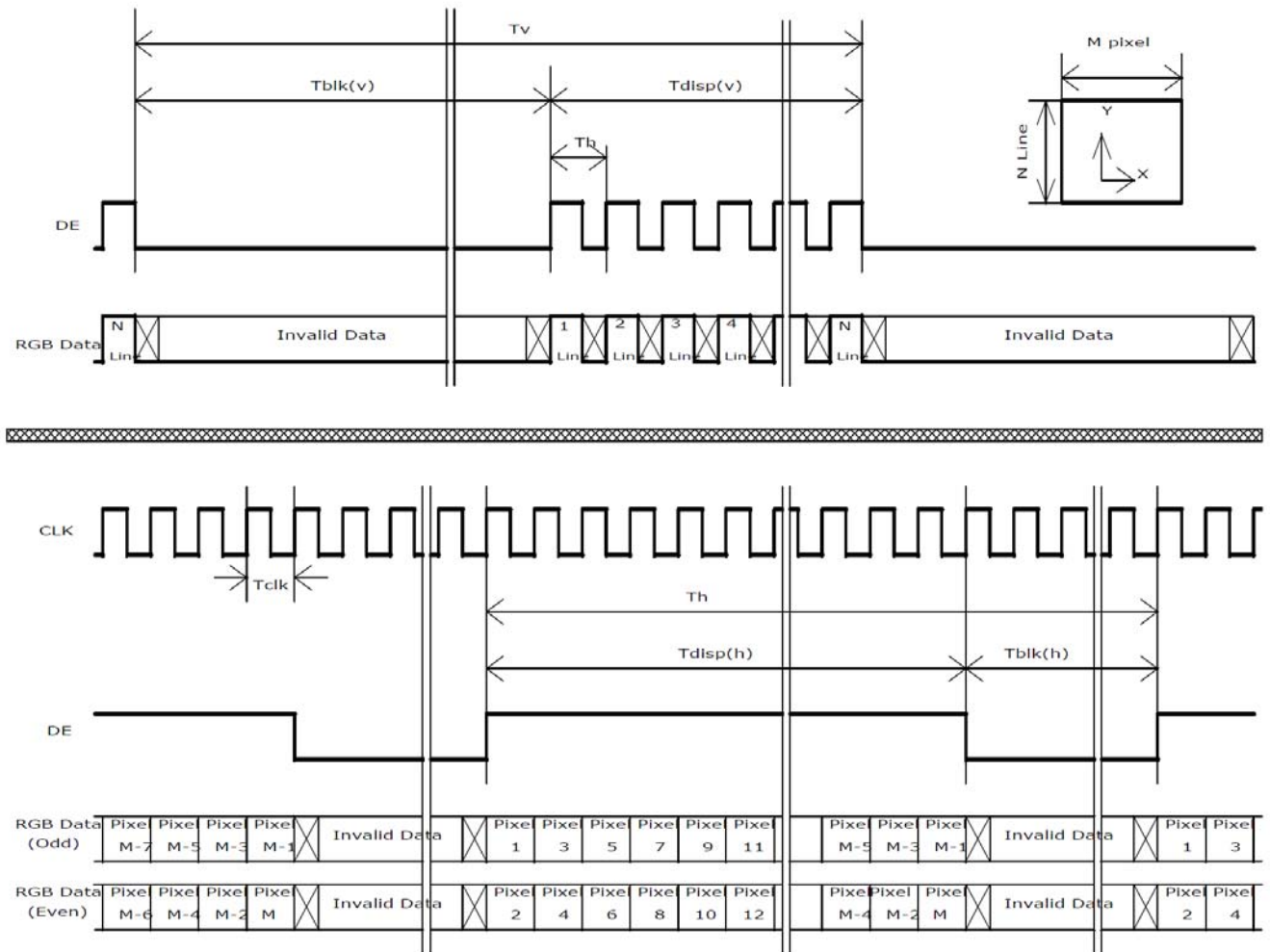

# Product Specification .

## 6.5 Power ON/OFF Sequence

VDD power and lamp on/off sequence is as follows. Interface signals are also shown in the chart. Signals from any system shall be Hi-Z state or low level when VDD is off.

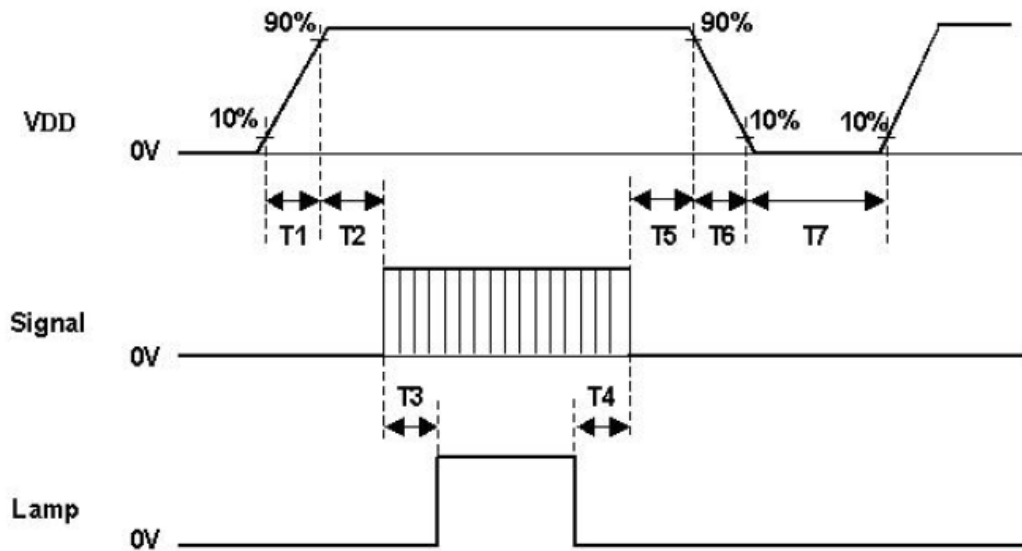

Parameter	Value			Unit
	Min.	Typ.	Max.	
T1	0.5	-	10	[msec]
T2	0	-	50	[msec]
T3	200	-	-	[msec]
T4	200	-	-	[msec]
T5	0	16	50	[msec]
T6	-	-	100	[msec]
T7	1000	-	-	[msec]

# Product Specification .

## 7.0 Connector & Pin Assignment

Physical interface is described as for the connector on module. These connectors are capable of accommodating the following signals and will be following components.

### 7.1 TFT LCD Module

Connector Name / Designation	Interface Connector / Interface card
Manufacturer	SIN SHENG / P-TWO
Type Part Number	MSCKT2407P30HB AL230F-A0G1D-P
Mating Housing Part Number	FI-X30HL (Locked Type) (TBD)

#### 7.1.1 Pin Assignment

Pin#	Signal Name	Pin#	Signal Name
1	RxOIN0-	2	RxOIN0+
3	RxOIN1-	4	RxOIN1+
5	RxOIN2-	6	RxOIN2+
7	GND	8	RxOCLK-
9	RxOCLK+	10	RxOIN3-
11	RxOIN3+	12	RxEIN0-
13	RxEIN0+	14	GND
15	RxEIN1-	16	RxEIN1+
17	GND	18	RxEIN2-
19	RxEIN2+	20	RxECLK-
21	RxECLK+	22	RxEIN3-
23	RxEIN3+	24	GND
25	NC	26	NC
27	NC	28	VDD
29	VDD	30	VDD

# Product Specification .

## 7.2 Backlight Unit (TBD)

Pin No.	Symbol	I/O	Function	Remark
1	VLED+	P	Power for LED backlight anode	White
2	VLED-	P	Power for LED backlight cathode	Black

LED Light Bar Connector is used for the integral backlight system. The recommended model is BHSR-02VS-1 manufactured by JST.

# Product Specification .

## 8. Reliability Test

Environment test conditions are listed as following table.

Items	Required Condition	Note
Temperature Humidity Bias (THB)	Ta= 50°C , 80%RH, 300hours	
High Temperature Operation (HTO)	Ta= 50°C , 50%RH, 300hours	3
Low Temperature Operation (LTO)	Ta= -10°C , 300hours	
High Temperature Storage (HTS)	Ta= 60°C , 300hours	
Low Temperature Storage (LTS)	Ta= -20°C , 300hours	
Drop Test	Height: 60 cm, package test	
Thermal Shock Test (TST)	-20°C/30min, 60°C/30min, 100 cycles	
On/Off Test	On/10sec, Off/10sec, 30,000 cycles	
ESD (ElectroStatic Discharge)	Contact Discharge: ± 8KV, 150pF(330Ω ) 1sec, 9 points, 25 times/ point.	
	Air Discharge: ± 15KV, 150pF(330Ω ) 1sec 9 points, 25 times/ point.	

Note 1: The TFT-LCD module will not sustain damage after being subjected to 100 cycles of rapid temperature change. A cycle of rapid temperature change consists of varying the temperature from -20°C to 60°C, and back again. Power is not applied during the test. After temperature cycling, the unit is placed in normal room ambient for at least 4 hours before power on.

Note 2: According to EN61000-4-2 , ESD class B: Some performance degradation allowed. No data lost. Self-recoverable. No hardware failures.

Note 3: The test items are tested by open frame type chassis.

# Product Specification .

9. Shipping Label & Package  
(TBD)





# Product Specification .

