



## CUSTOMER' S APPROVAL SPECIFICATIONS

**MODEL: CH070OLDT-001**

**(Complied with RoHS)**

**ISSUE:JUN.14.2012**

**Spec Condition: Preliminary**

No.	ITEM	PAGE
1	COVER	--
2	RECORD OF REVISION	0-1
3	MECHANICAL SPECIFICATIONS	1
4	OUTLINE DIMENSIONS	2
5	INTERFACE PIN CONNECTION	3
6	BLOCK DIAGRAM	4
7	ABSOLUTE MAXIMUM RATINGS	4
8	ELECTRICAL CHARACTERISTICS	5
9	OPTICAL CHARACTERISTICS	6~8
10	TIMING SPECIFICATIONS	9~10
11	RELIABILITY TEST	11

CUSTOMER	CHEFREE		
APPROVAL	APPROVAL	CHECKER	PREPARE
	<i>ch lee</i>	<i>ch lee</i>	<i>cloud</i>

## 2.RECORD OF REVISION

Rev	DATE	PAGE	SUMMARY
0.1	2012.06.14	ALL	Preliminary specification was first issued.

### 3.MECHANICAL SPECIFICATIONS

(1)	Number Of Dots (Dots)	800(R.G.B) X 480
(2)	Module Size(mm)	165.0(W) X 106.4(H) X 6.3(D)
(3)	Active Area(mm)	152.4(H) X 91.44(V)
(4)	Pixel Size(mm)	0.0635(H) X 0.1905(V)
(5)	Pixel Pitch(mm)	0.1905(H) X 0.1905(V)
(6)	LCD / Polarizer Model	TFT , Transmissive, Normally/White,Anti-glare
(7)	Backlight Color	LED ,White
(8)	Viewing Direction	12 O'clock
(9)	Gray Scale Inversion Direction	6 O'clock
(10)	Color Configuration	R.G.B Stripe
(11)	Module Weight(g)	115±5%

\*\*Viewing direction for best image quality is different from TFT definition, there is the 180 degrees shift.

# 4. OUTLINE DIMENSIONS

1	2	3	4
文件題目	圖號	頁	次頁
發行日	舊版日	登入號碼	機密等級

7		8 樣式 QT3-RD-E-0004-003	
No.	修訂區塊	修訂內容	作成 修訂日期
		新版	Bella 2012.06.13

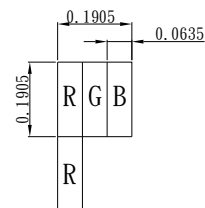
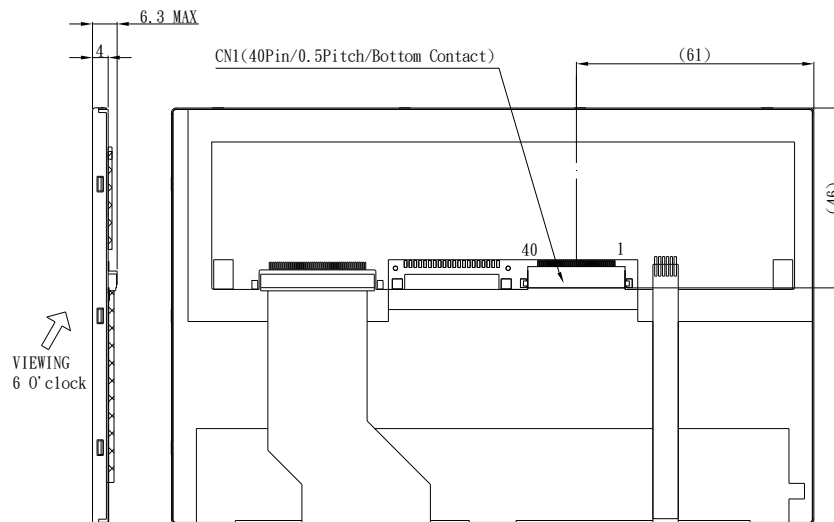
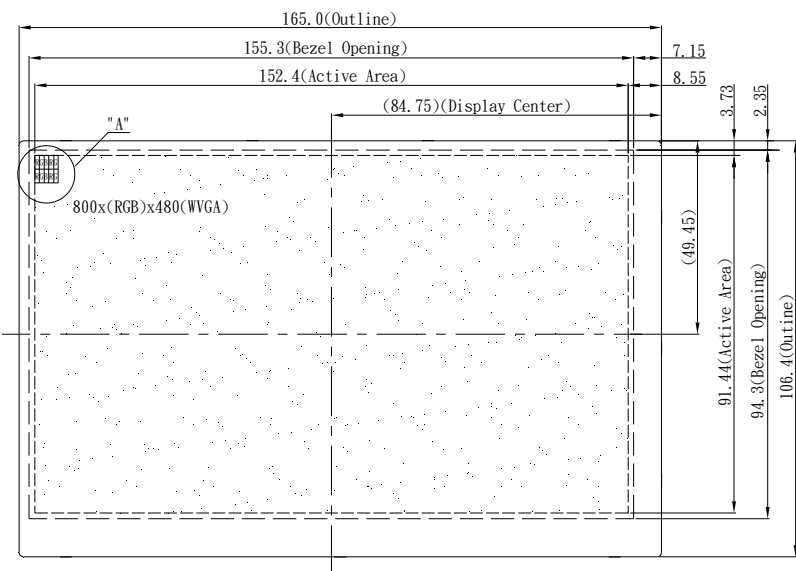

Detail "A"  
Scale=100:1

NOTE:

1. UNIT:mm
2. General tolerance:±0.3mm
3. CN1:STARCONN 089N40-000R00-G2-R or Equivalet

備考	單位:mm	投影法:	比例尺: 1:1
入庫	製圖: Bella 120613	名稱: 7" LCM	圖號: CH0700LDT-001
	審查		
	承認		

## 5. INTERFACE PIN CONNECTION

### 5.1 LCM PANEL DRIVING SECTION (CN1 Connector: Starconn 089N40-000R00-G2)

PIN NO	SYMBOL	FUNCTION	REMARK
1	GND	GROUND	
2	GND	GROUND	
3	ADJ	BRIGHTNESS CONTROL FOR LED B/L	
4	VLED	POWER SUPPLY FOR LED DRIVER CIRCUIT	
5	VLED	POWER SUPPLY FOR LED DRIVER CIRCUIT	
6	VLED	POWER SUPPLY FOR LED DRIVER CIRCUIT	
7	VCC	POWER SUPPLY FOR DIGITAL CIRCUIT	
8	VCC	POWER SUPPLY FOR DIGITAL CIRCUIT	
9	DE	DATA ENABLE	
10	GND	GROUND	
11	GND	GROUND	
12	GND	GROUND	
13	B5	BLUE DATA SIGNAL(MSB)	
14	B4	BLUE DATA SIGNAL	
15	B3	BLUE DATA SIGNAL	
16	GND	GROUND	
17	B2	BLUE DATA SIGNAL	
18	B1	BLUE DATA SIGNAL	
19	B0	BLUE DATA SIGNAL(LSB)	
20	GND	GROUND	
21	G5	GREEN DATA SIGNAL(MSB)	
22	G4	GREEN DATA SIGNAL	
23	G3	GREEN DATA SIGNAL	
24	GND	GROUND	
25	G2	GREEN DATA SIGNAL	
26	G1	GREEN DATA SIGNAL	
27	G0	GREEN DATA SIGNAL(LSB)	
28	GND	GROUND	
29	R5	RED DATA SIGNA(MSB)	
30	R4	RED DATA SIGNA	
31	R3	RED DATA SIGNA	
32	GND	GROUND	
33	R2	RED DATA SIGNA	
34	R1	RED DATA SIGNA	
35	R0	RED DATA SIGNA(LSB)	
36	GND	GROUND	
37	GND	GROUND	
38	DCLK	CLOCK SIGNALS	
39	GND	GROUND	
40	GND	GROUND	

## 6. BLOCK DIAGRAM

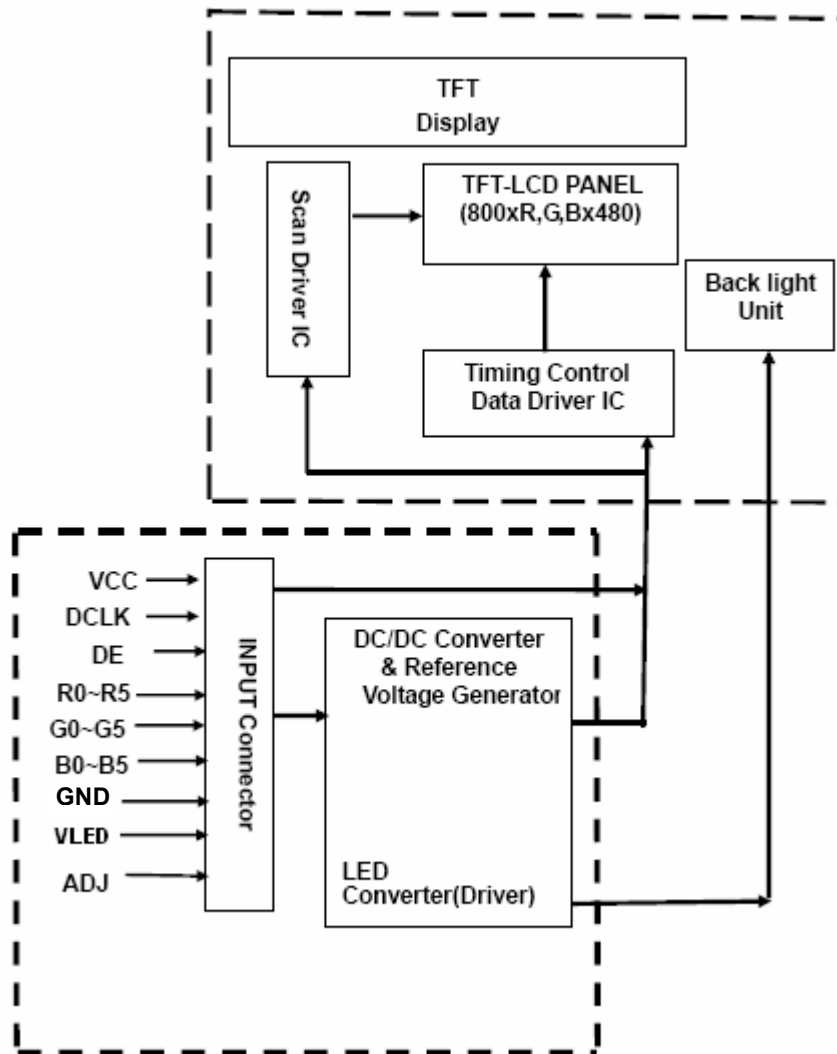

## 7. ABSOLUTE MAXIMUM RATINGS

### 7.1 ELECTRICAL ABSOLUTE MAXIMUM RATINGS

ITEM	SYMBOL	MIN.	MAX.	UNIT	COMMENT
Power Supply Voltage	VCC	-0.3	+7.0	V	
Logic Output Voltage	V <sub>I</sub>	-0.3	VCC+0.3	V	

### 7.2 ENVIRONMENTAL ABSOLUTE MAXIMUM RATINGS

ITEM	OPERATING		STORAGE		COMMENT
	MIN	MAX	MIN	MAX	
Ambient Temperature(°C)	-20	70	-30	80	Note 1,2,3
Humidity(% RH)	-	90	-	90	Note 4

Note 1 : The response time will become lower when operated at low temperature.

Note 2 : Background color changes slightly depending on ambient temperature.

Note 3 : Operation Ta=70°C & -20°C ≤ 240Hrs.

Note 3 : Storage Ta=60°C & RH=90% ≤ 240Hrs.

## 8. ELECTRICAL CHARACTERISTICS

### 8.1 ELECTRICAL CHARACTERISTICS OF LCD

Ta=25°C

ITEM	SYMBOL	MIN.	TYP.	MAX.	UNIT
Power Voltage for LCD	VCC	3.0	3.3	3.6	V
	ICC	-	225	337.5	mA
Input High Voltage	V <sub>IH</sub>	0.7*VCC	-	VCC	V
Input Low Voltage	V <sub>IL</sub>	GND	-	0.3*VCC	V
Output High Voltage	V <sub>OH</sub>	0.8VCC	-	VCC	V
Output Low Voltage	V <sub>OL</sub>	GND	-	0.2VCC	V

### 8.2 BACKLIGHT UNITS

Ta=25°C

ITEM	SYMBOL	MIN	TYP	MAX	UNIT
LED Driving Voltage	VLED	3	5	5.5	V
LED Driving Current	I <sub>LED</sub> (VLED=3.3V)	-	650	850	mA
	I <sub>LED</sub> (VLED=5V)	-	400	550	mA
ADJ Input Voltage	-	3	-	3.3	V
ADJ Frequency	-	19	20	21	KHz

※ USE NICHIA LED.

Note 1: LED Number

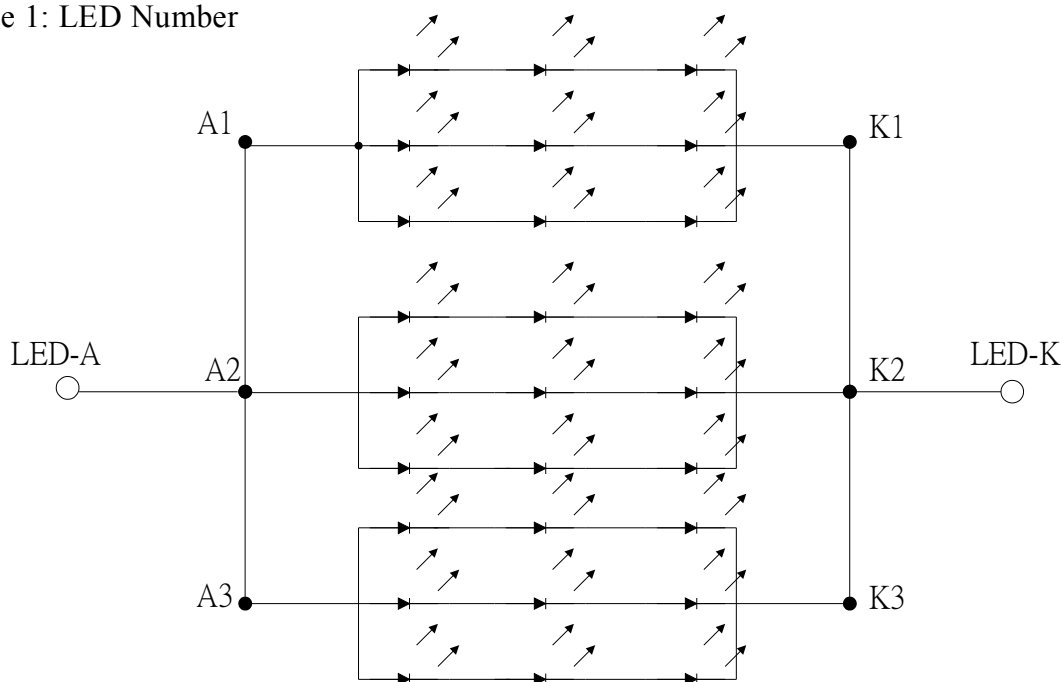

Note 2: The LED of B/L is drive by current only, drive voltage is for reference only, drive voltage can make driving current under safety area(current between minimum and maximum). 20K hours is only an estimate for reference.

# 9.OPTICAL CHARACTERISTICS

Ta=25°C

ITEM	SYMBOL	CONDITIONS	MIN.	TYP.	MAX.	UNIT	REMARK	
Contrast Ratio	CR	At optimized Viewing angle	300	400	-	-	Note (1)	
Response Time	TR	T=0	-	5	10	ms	Note (2)	
	TF		-	15	20	ms		
Chromaticity	White	Viewing Angle $\Theta_x = \Theta_y = 0^\circ$	x	0.28	0.33	0.38	-	Note (4)
			y	0.33	0.38	0.43	-	
Viewing Angle	$\Theta_{x+}$	$CR \geq 10$	60	70	-	Deg.	Note (3)	
	$\Theta_{x-}$		60	70	-			
	$\Theta_{y+}$		40	50	-			
	$\Theta_{y-}$		50	60	-			
Luminance	L	ADJ=3.3V	400	500	-	cd/m2		
Luminance uniformity	YU		70	-	-	%	Note (5)	

\*Note (1) Definition of Contrast Ratio (CR):

The contrast ratio can be calculated by the following expression.

$$\text{Contrast Ratio (CR)} = L_{63} / L_0$$

L63: Luminance of gray level 63

L 0: Luminance of gray level 0

$$CR = CR (5)$$

CR (X) is corresponding to the Contrast Ratio of the point X at Figure in Note (5).

\*Note (2) Definition of Response Time ( $T_R$ ,  $T_F$ ):

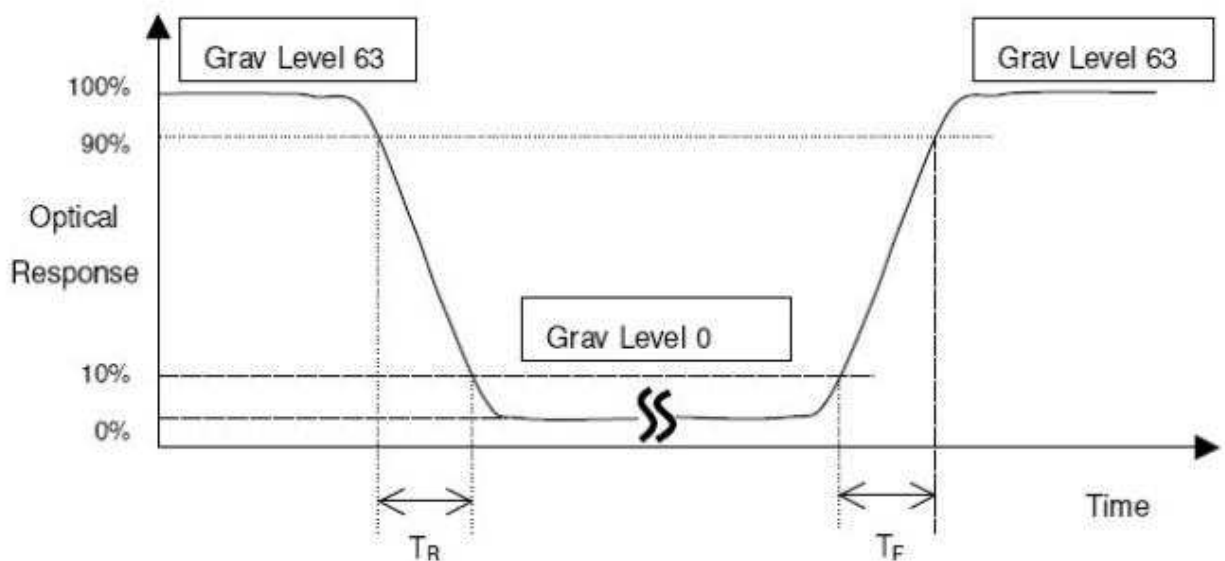



\*Note(3) Definition of Viewing Angle

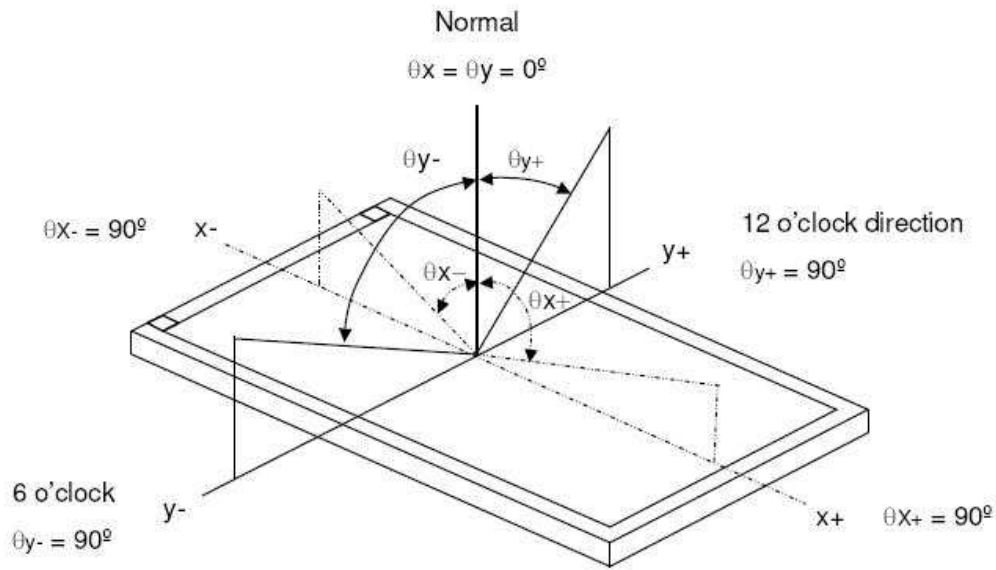

\*Note (4) Measurement Set-Up:

The LCD module should be stabilized at a given temperature for 20 minutes to avoid abrupt temperature change during measuring. In order to stabilize the luminance, the measurement should be executed after lighting Backlight for 20 minutes in a windless room.

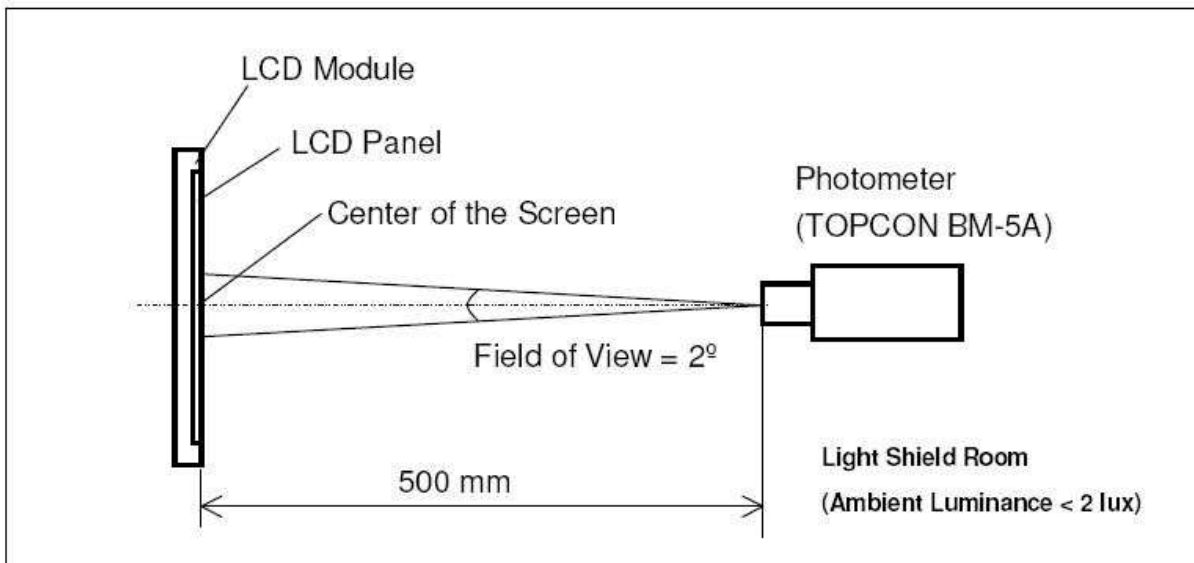

\*Note (5)

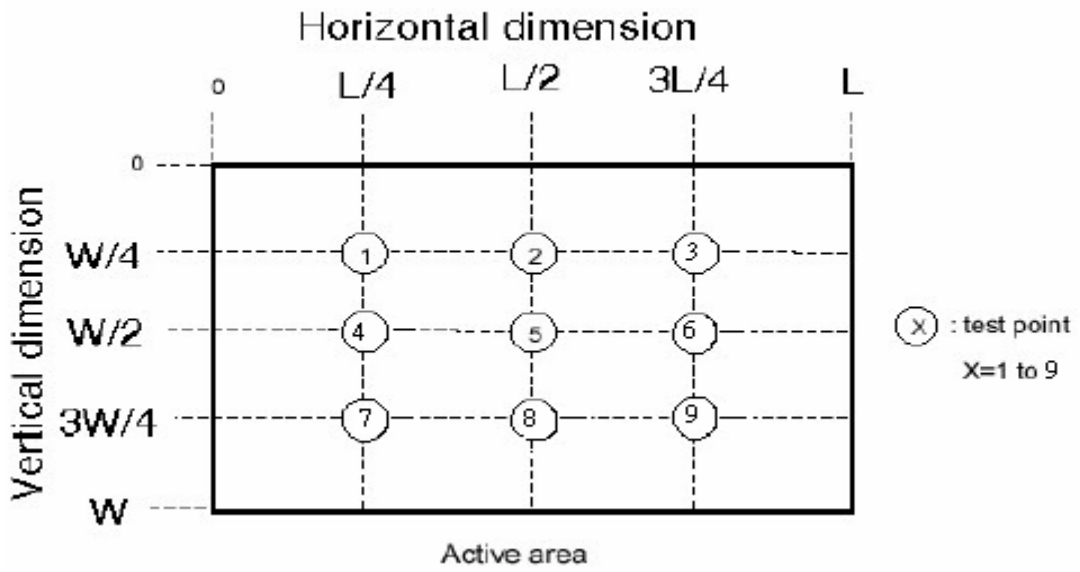

$$\left( 1 - \frac{\text{MAX Luminance} - \text{Average Luminance}}{\text{Average Luminance}} \right) \times 100\% > 70\%$$

# 10. TIMING SPECIFICATIONS

## 10.1 POWER SIGNAL SEQUENCE

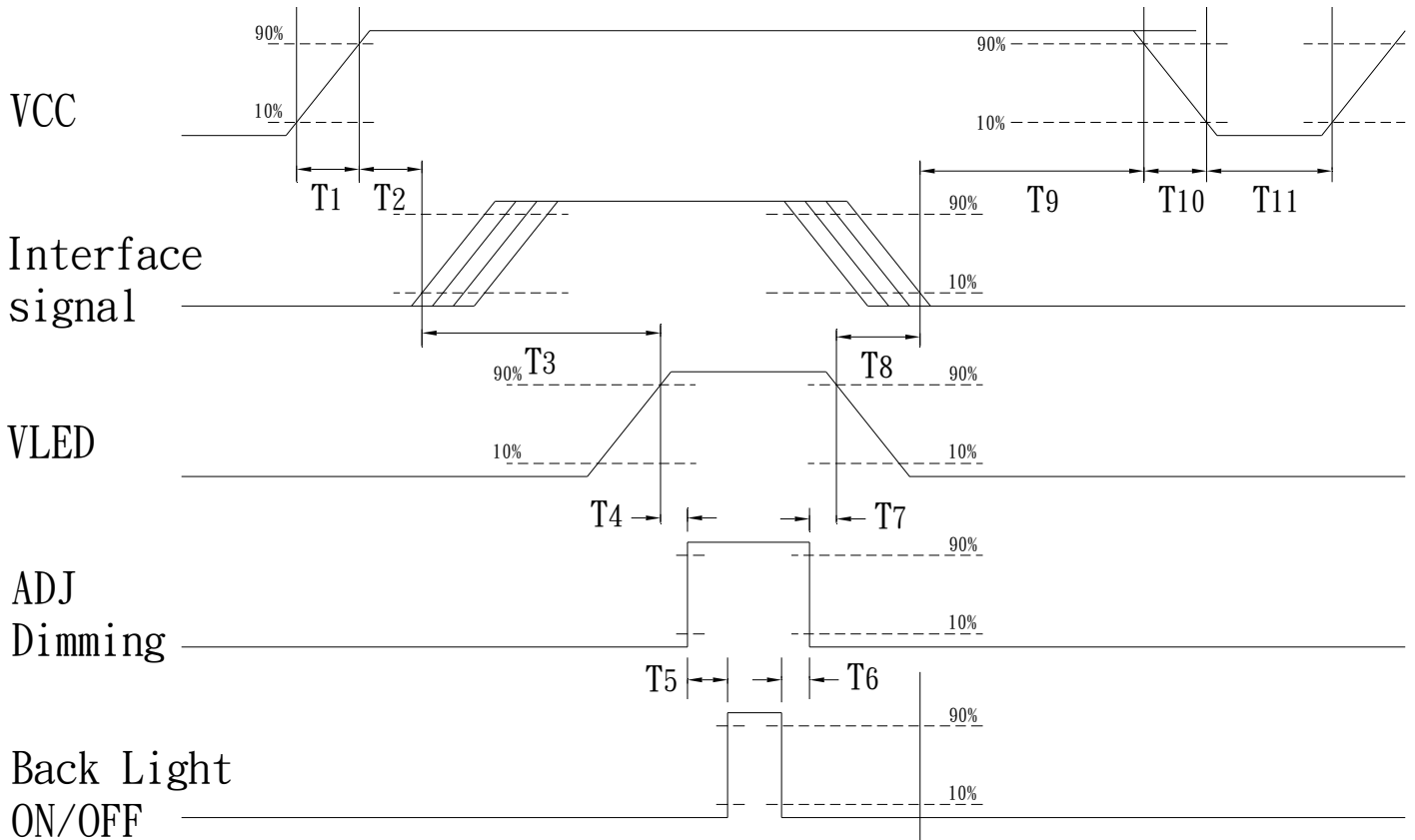

Power ON/OFF sequence timing

PARAMETER	MIN.	TYP.	MAX.	UNIT
T1	0.5	-	10	ms
T2	0	-	50	ms
T3	200	-	-	ms
T4	10	-	-	ms
T5	10	-	-	ms
T6	0	-	-	ms
T7	10	-	-	ms
T8	100	-	-	ms
T9	0	16	50	ms
T10	-	-	10	ms
T11	1000	-	-	ms

The above on/off sequence should be applied to avoid abnormal function in the display. Please make sure to turn off the power when you plug the cable into the input connector or pull the cable out of the connector.

## 10.2 AC TIMING CHARACTERISTICS

PARAMETER		SYMBOL	MIN.	TYP.	MAX.	UNIT	CONDITION
Clock	Frequency	$1/T_c$	-	33.26	-	MHz	Note1
	Clk pulse duty	$T_{cwh}$	40	50	60	%	Note1
	Clk cycle time	$T_{cph}$	25	-	-	ns	Note1
Data	Setup time	$T_{dsu}$	6	-	-	ns	Note1
	Hold time	$T_{dhd}$	6	-	-	ns	Note1
ENAB signal	Setup time	$T_{esu}$	6	-	-	ns	Note1

Note 1: Frame rate is 60 Hz at 3.3V VCC

Clock and Data Timing Diagram

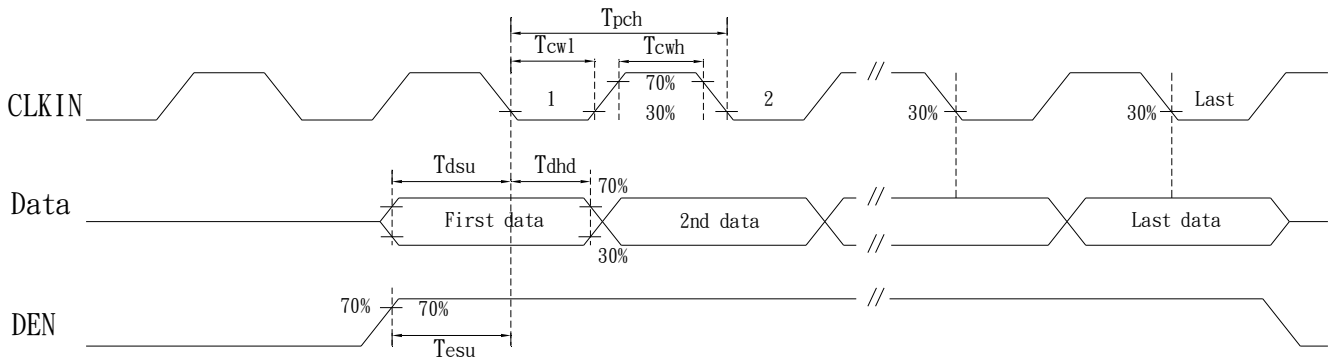

## 10.3 DE MODE DATA FORMAT

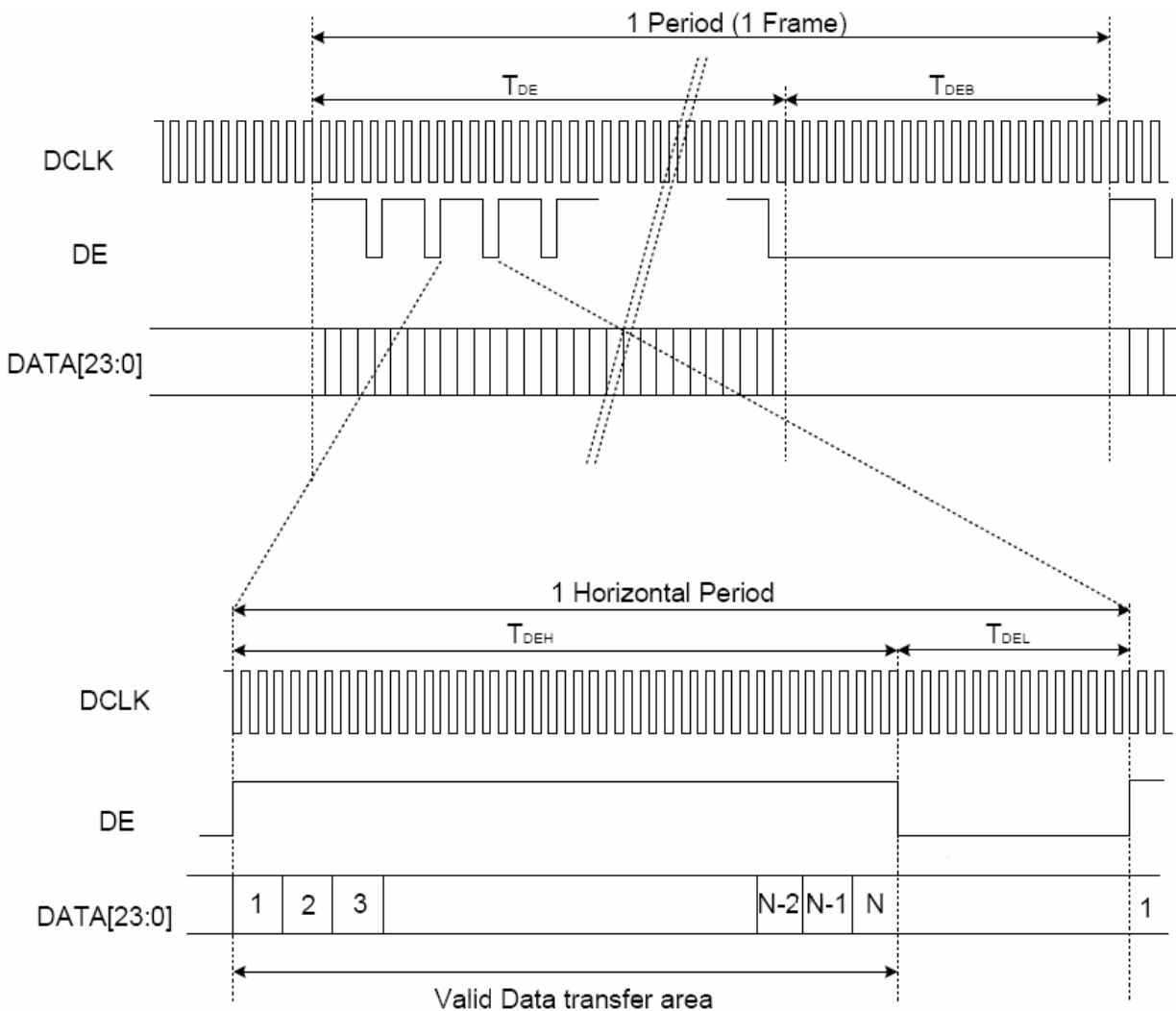

## 11. RELIABILITY TEST

Environmental Test				
NO.	ITEM	CONDITIONS	TIME PERIOD	REMARK
1	High Temperature Storage	80°C	240HRS	
2	Low Temperature Storage	-30°C	240HRS	
3	High Temperature Humidity Storage	60°C 90%RH	240HRS	NOTE(2)
4	High Temperature Operation	70°C	240HRS	NOTE(2)
5	Low Temperature Operation	-20°C	240HRS	NOTE(2)
6	Temperature Cycle	-20°C ← 25°C → 70°C (30min) (5min) (30min)	30CYCLE	NOTE(2)

NOTE (1) : a. THE MODULE SHOULD WORK PROPERLY.

b. BEFORE AND AFTER FUNCTION TEST, THE DIFFERENCE OF CONSUMPTIVE CURRENT SHOULD BE WITHIN 10%

NOTE (2) : a. THE MODULE SHOULD WORK PROPERLY.

b. THE MODULE WON'T BE DEFORMATIVE, COLOR CHANGEABLE OR BROKEN.

c. THE MODULES CAN'T BE APART.

NOTE (3) : BEFORE COSMETIC AND FUNCTION TEST, THE PRODUCT MUST HAVE ENOUGH RECOVERY TIME, AT LEAST 2 HOURS AT ROOM TEMPERATURE.