



CUSTOMER' S APPROVAL SPECIFICATIONS

MODEL: CH057DLCT-002

(Complied with RoHS)

ISSUE:Jul.12.2012

Spec Condition: Preliminary

No.	ITEM	PAGE
1	COVER	--
2	RECORD OF REVISION	0-1
3	MECHANICAL SPECIFICATIONS	1
4	OUTLINE DIMENSIONS	2
5	INTERFACE PIN CONNECTION	3
6	BLOCK DIAGRAM	4
7	ABSOLUTE MAXIMUM RATINGS	4
8	ELECTRICAL CHARACTERISTICS	5
9	OPTICAL CHARACTERISTICS	6~8
10	TIMING SPECIFICATIONS	9~12
11	RELIABILITY TEST	13
12	USE PRECAUTIONS	14~15

CUSTOMER	CHEFREE		
APPROVAL	APPROVAL	CHECKER	PREPARE
	<i>ch lee</i>	<i>kevin</i>	<i>well</i>

2.RECORD OF REVISION

Rev	DATE	PAGE	SUMMARY
0.1	2012.07.12	ALL	Preliminary specification was first issued

3.MECHANICAL SPECIFICATIONS

NO.	ITEM	SPECIFICATION
(1)	Number Of Dots (Dots)	640(R.G.B) X 480
(2)	Module Size(mm)	127.0(W) x 98.43(H) x7(D)
(3)	Active Area(mm)	115.2 (W) x 86.4(H)
(4)	Pixel Pitch(mm)	0.06 (W) x 0.18 (H)
(5)	LCD Model	TFT
(6)	Backlight Color	White LED
(7)	Viewing Direction	6 O'clock
(8)	Gray Scale Inversion Direction	12 O'clock
(9)	Color Configuration	R.G.B Stripe
(10)	Module Weight(g)	(110)

Note:Viewing direction for best image quality is different from TFT definition, ther is the 180 degrees shift.



4. OUTLINE DIMENSIONS

1	2	3	4
文件題目	圖號	頁	次頁
發行日	舊版日	登入號碼	機密等級

7			8 樣式 QT3-RD-E-0004-003	
No.	修訂區塊	修訂內容	作成	修訂日期
		新版	Empire	

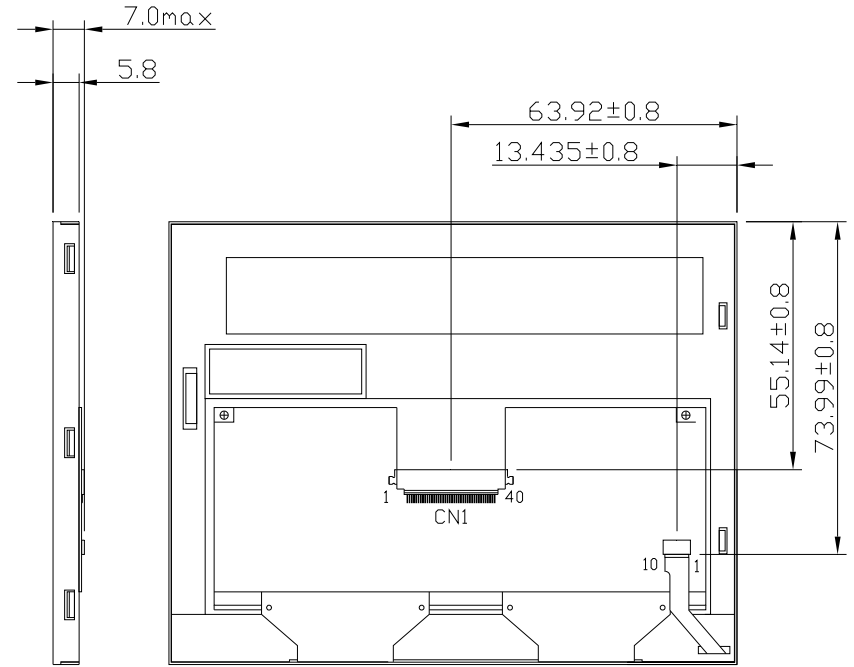
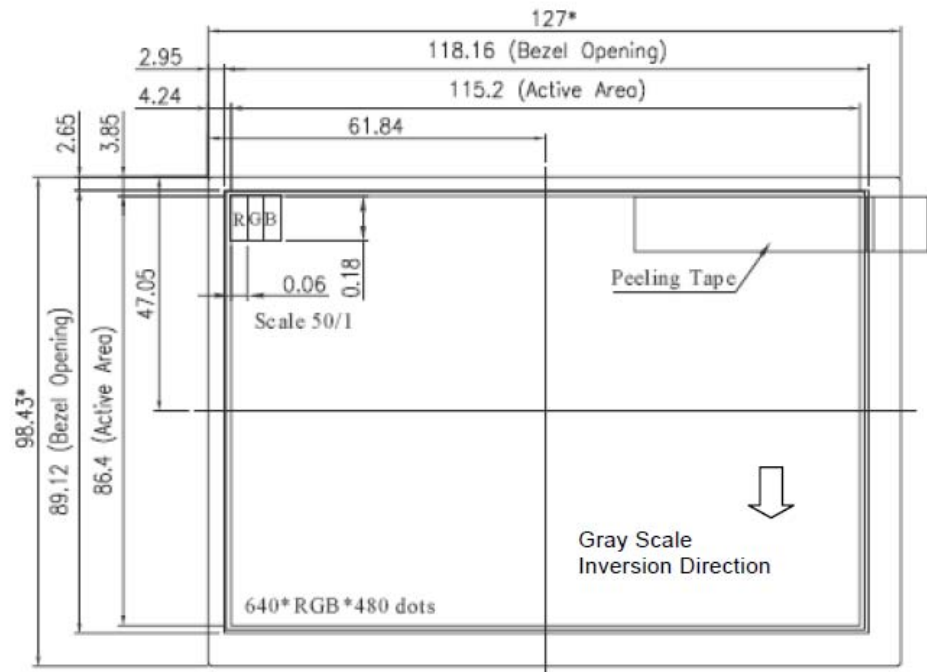

- NOTE:
1. Unit:mm
 2. Without Tolerance ± 0.3
 3. CN1 Connector: JAE FA5B040HP1 or Equivalent.

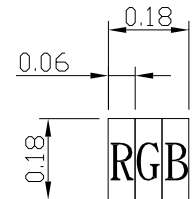

備考	單位:mm	投影法:	比例尺: 1:1
入庫	製圖 Empire 111104	名稱: 5.7" LCM	圖號 CH057DLCT-002
	審查		
	承認		

A
B
C
D
E
F

5. INTERFACE PIN CONNECTION

5.1 LCM PANEL DRIVING SECTION

40PIN Connector : JAE FA5B040HP1 or Equivalent.

PIN NO.	SYMBOL	FUNCTION	REMARK
1	U/D	Up or Down Display Control	Note 1
2	NC	No Connection	
3	HSYNC	Horizontal SYNC.	
4	VLED	Power Supply for LED Driver circuit	
5	VLED	Power Supply for LED Driver circuit	
6	VLED	Power Supply for LED Driver circuit	
7	VCC	Power Supply for LCD	
8	VSYNC	Vertical SYNC.	
9	DE	Data Enable	Note 2
10	VSS	Power Ground	
11	VSS	Power Ground	
12	ADJ	Brightness control for LED B/L	
13	B5	Blue Data 5 (MSB)	
14	B4	Blue Data 4	
15	B3	Blue Data 3	
16	VSS	Power Ground	
17	B2	Blue Data 2	
18	B1	Blue Data 1	
19	B0	Blue Data 0 (LSB)	
20	VSS	Power Ground	
21	G5	Green Data 5 (MSB)	
22	G4	Green Data 4	
23	G3	Green Data 3	
24	VSS	Power Ground	
25	G2	Green Data 2	
26	G1	Green Data 1	
27	G0	Green Data 0 (LSB)	
28	VSS	Power Ground	
29	R5	Red Data5 (MSB)	
30	R4	Red Data 4	
31	R3	Red Data 3	
32	VSS	Power Ground	
33	R2	Red Data 2	
34	R1	Red Data 1	
35	R0	Red Data 0 (LSB)	
36	VSS	Power Ground	
37	VSS	Power Ground	
38	DCLK	Clock Signals; Latch Data at the Falling Edge	
39	VSS	Power Ground	
40	L/R	Left or Right Display Control	Note 1

Note 2: If DE signal is fixed low, SYNC mode is used. Otherwise, DE mode is used.

6. BLOCK DIAGRAM

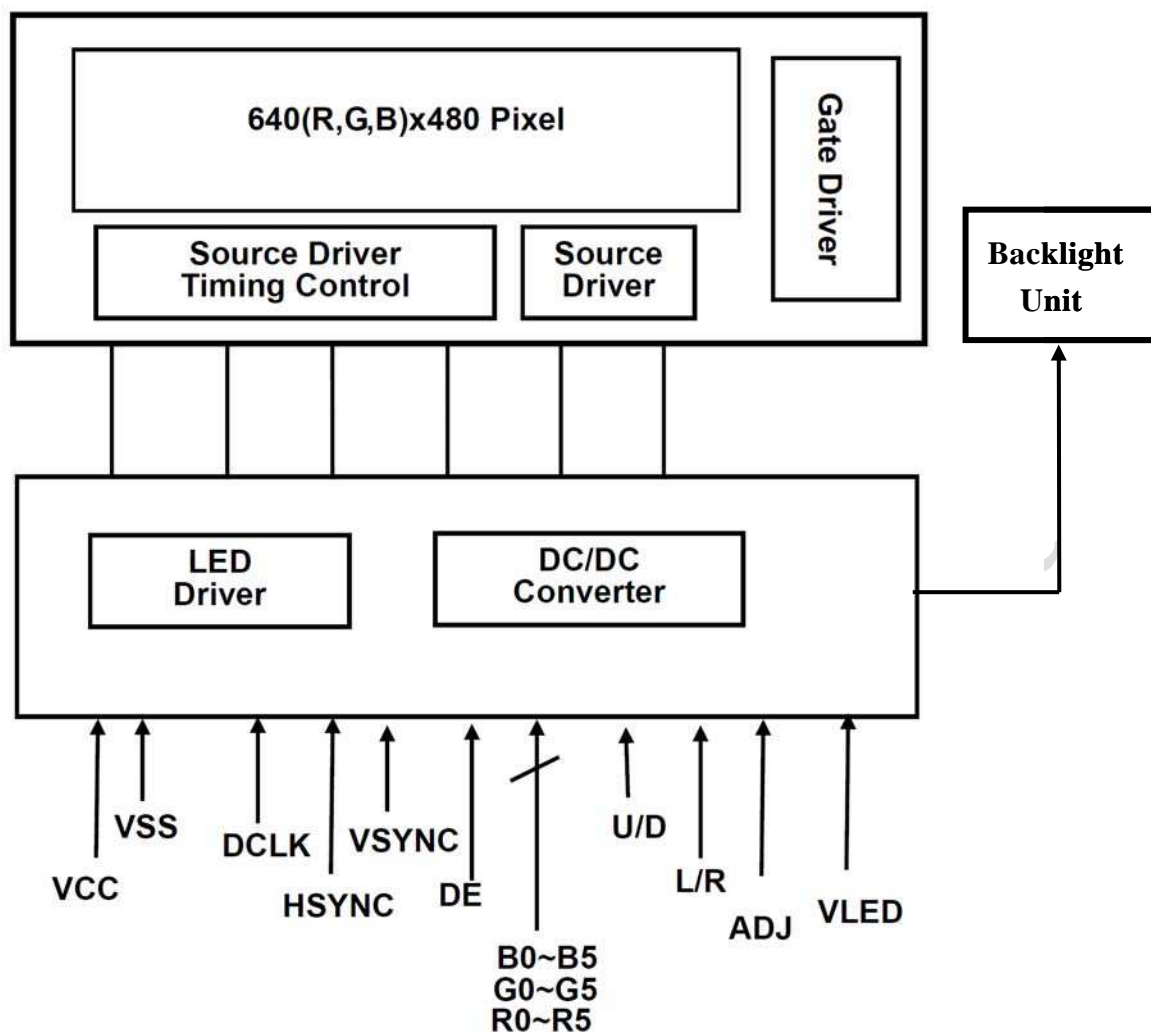

7. ABSOLUTE MAXIMUM RATINGS

7.1 ELECTRICAL ABSOLUTE MAXIMUM RATING

ITEM	SYMBOL	MIN.	MAX.	UNIT	REMARK
Power Supply Voltage	VCC	-0.3	+5.0	V	
Signal Input Voltage	VI	-0.3	VCC+0.3	V	

7.2 ENVIRONMENTAL ABSOLUTE MAXIMUM RATINGS

ITEM	OPERATING		STORAGE		REMARK
	MIN.	MAX.	MIN.	MAX.	
Ambient Temperature[°C]	-20	70	-30	80	Note 1,2,3
Humidity[%RH]	Note 4				

Note 1 : The response time will become lower when operated at low temperature.

Note 2 : Background color changes slightly depending on ambient temperature.

Note 3 : Operation $T_a=70^{\circ}\text{C}$ & $-20^{\circ}\text{C} \leq 240\text{Hrs}$.

Note 4 : Operation $T_a=60^{\circ}\text{C}$ & $H=90\% \leq 240\text{Hrs}$.

8.ELECTRICAL CHARACTERISTICS

8.1 LCM ELECTRICAL CHARACTERISTICS

Ta=25°C

ITEM	SYMBOL	MIN.	TYP.	MAX.	UNIT
Power supply for LCD	VCC	3.0	3.3	3.6	V
	ICC **	-	(111)	(140)	mA
Input High Voltage	V _{IH}	0.7*VCC	-	VCC	V
Input Low Voltage	V _{IL}	0	-	0.3*VCC	V
Ripple Voltage	VRF	-	-	100	mV _{P-P}

**Test pattern:Black

8.2 BACKLIGHT UNITS

Ta=25°C

ITEM	SYMBOL	MIN.	TYP.	MAX.	UNIT	REMARK
LED Driver Voltage	VLED	4.5	5	5.5	V	
	ILED	-	333	-	mA	
ADJ frequency	-	19	20	21	KHz	
ADJ Input Voltage	ADJ _{IH}	3.0	-	3.3	V	
	ADJ _{IL}	0	-	0.3	V	
LED Life Time (For Reference only)	Ta=25°C 60-70%RH	-	50000	-	Hr	Note 1

Note1:LED number

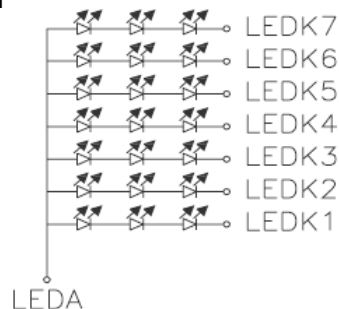

Note2:The LED of B/L is drive by current only, drive Voltage is for reference only, drive voltage can make driving current under safety area (current Between minimum and maximum).50K hours is only an estimate for reference.

9.OPTICAL CHARACTERISTICS

Ta=25°C

ITEM	SYMBOL	CONDITIONS	MIN.	TYP.	MAX.	UNIT	REMARK	
Contrast Ratio	CR	Viewing normal angle $\theta X = \theta Y = 0^\circ$	200	300	-	-	Note (1)	
Response Time	TR		-	15	-	ms	Note (2)	
	TF		-	35	-			
Brightness	L		(720)	(900)	-	cd/m2		
Uniformity	YU		70	80	-	%	Note (5)	
Color Chromaticity	Red		X _R	(0.565)	(0.615)	(0.665)	-	Note (4)
			Y _R	(0.310)	(0.360)	(0.410)		
	Green		X _G	(0.295)	(0.345)	(0.395)		
			Y _G	(0.490)	(0.540)	(0.590)		
	Blue		X _B	(0.098)	(0.148)	(0.198)		
		Y _B	(0.056)	(0.106)	(0.156)			
	White	X _W	(0.259)	(0.309)	(0.359)			
		Y _W	(0.270)	(0.320)	(0.370)			
Viewing Angle	$\theta Y+$	Viewing normal angle $\theta X = \theta Y = 0^\circ$ CR ≥ 10	50	60	-	Deg.	Note (3)	
	$\theta Y-$		30	40	-			
	$\theta X+$		60	70	-			
	$\theta X-$		60	70	-			
Image Stick	tis	2 hours	-	-	2	sec	Note (6)	

Note (1) Definition of Contrast Ratio(CR):

The contrast ratio can be calculated by the following expression

$$\text{Contrast Ratio (CR)} = L_{63}/L_0$$

L₆₃:Luminance of gray level 63

L₀:Luminance of gray level 0

$$CR = CR(5)$$

CR(X) is corresponding to the Contrast Ratio of the point X at Figure in Note(5)

Note(2) Definition of Response Time(TR,TF):

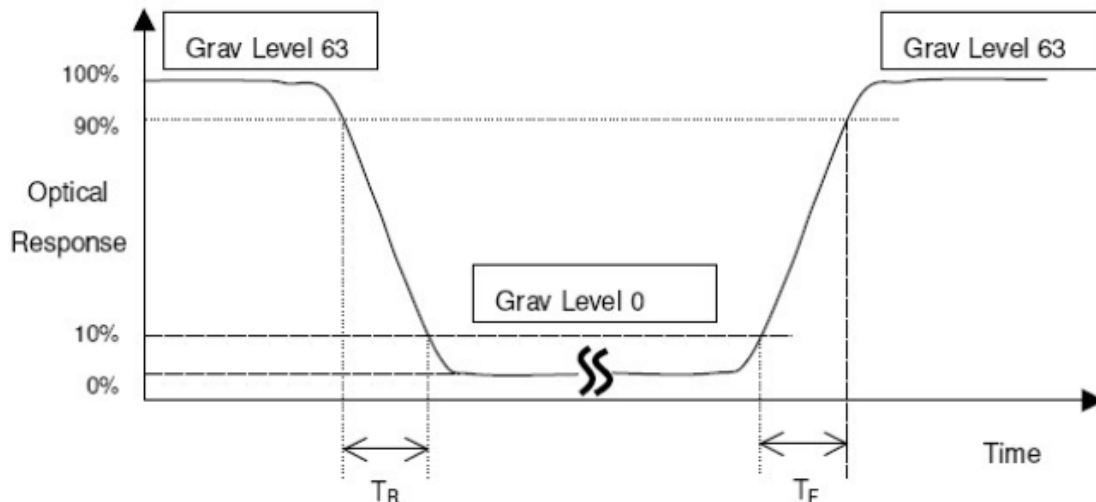

Note (3) Definition of Viewing Angle

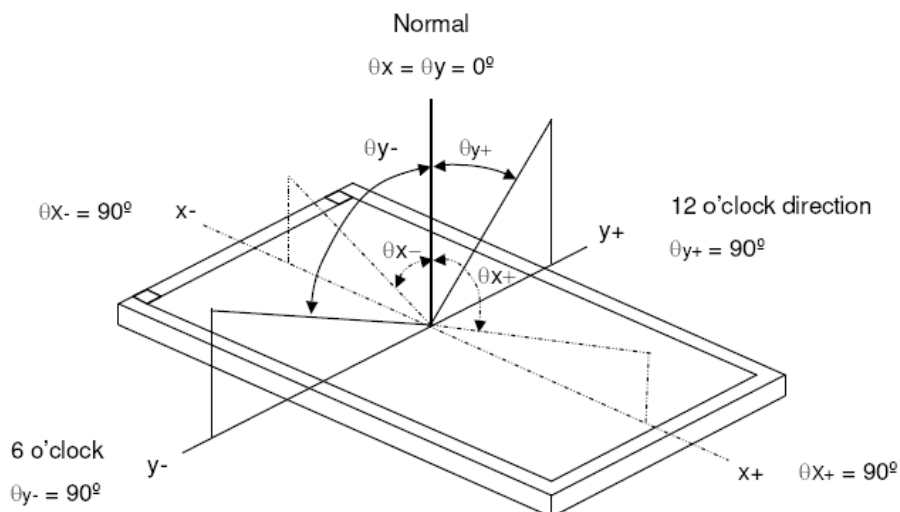

Note (4) Measurement Set-Up:

The LCD module should be stabilized at a given temperature for 20 minutes to avoid abrupt temperature change during measuring. In order to stabilize the luminance, the measurement should be executed after lighting Backlight for 20 minutes in a windless room.

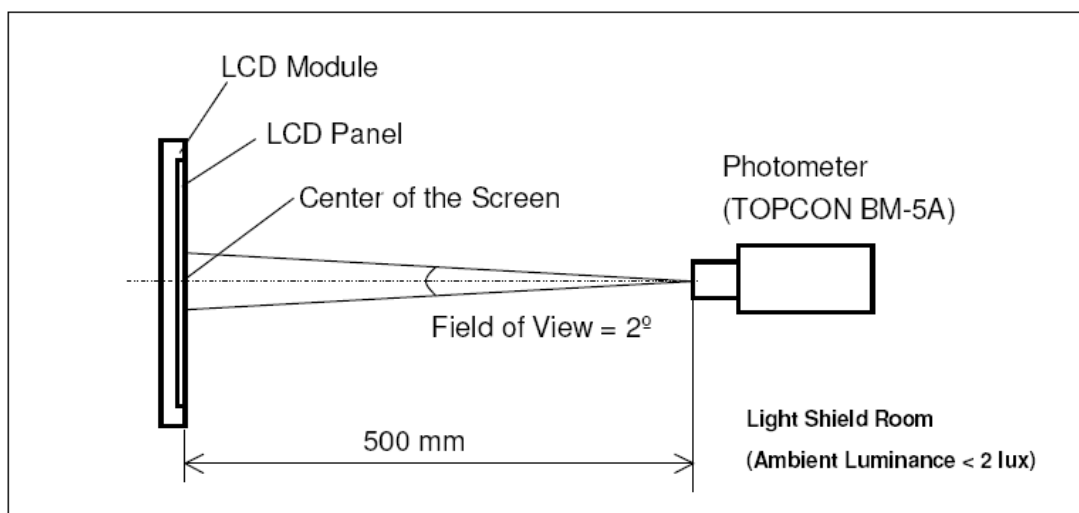

Note (5)

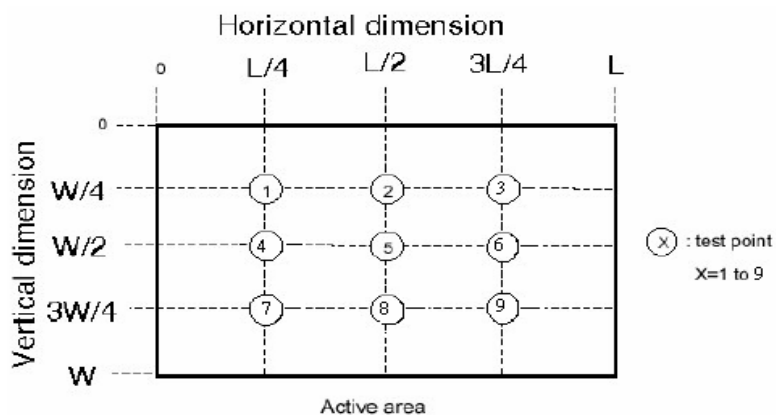

$$\left(1 - \frac{\text{MAX Luminance} - \text{Average Luminance}}{\text{Average Luminance}} \right) \times 100\% \geq 70\%$$

Note (6) Definition of Image sticking (tis):

Continuously display the test pattern shown in the figure below for 2 hours. Then display a completely white screen. The previous images shall not persist more than 2 sec at 25 °C.

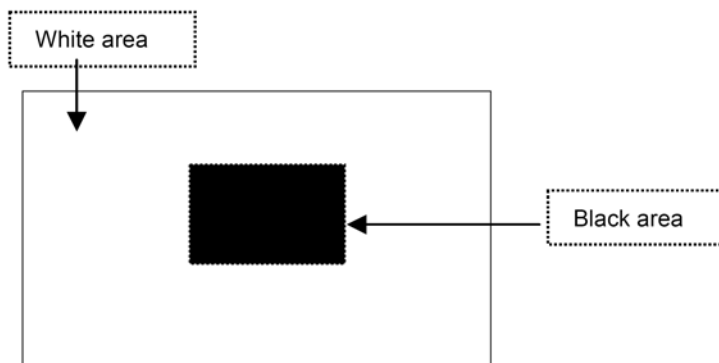

10. TIMING SPECIFICATIONS

10.1 POWER SIGNAL SEQUENCE

10.1.1: Power Signal sequence:

$$t1 \leq 10\text{ms} : 1 \text{ sec} \leq t5$$

$$50\text{ms} \leq t2 : 200\text{ms} \leq t6$$

$$0 < t3 \leq 50\text{ms} : 200\text{ms} \leq t7$$

$$0 < t4 \leq 10\text{ms}$$

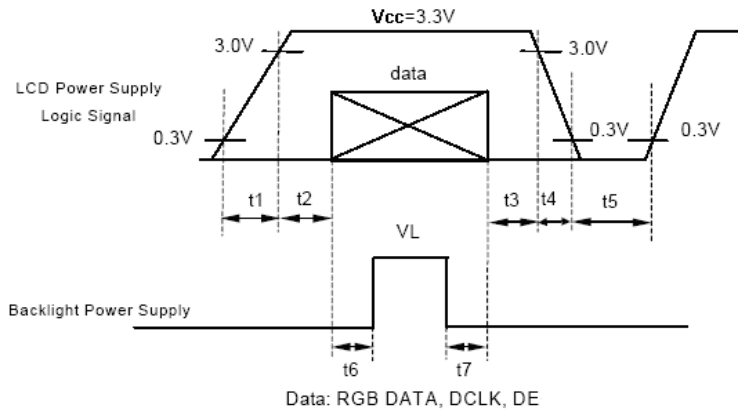

10.1.2: VCC-dip condition:

$$10.5.2.1: 2.7 \text{ V} \leq VCC < 3.0\text{V}, t_d \leq 10 \text{ ms}$$

10.5.2.2: $VCC > 3.0\text{V}$, VCC-dip condition should be the same with VCC-turn-on condition.

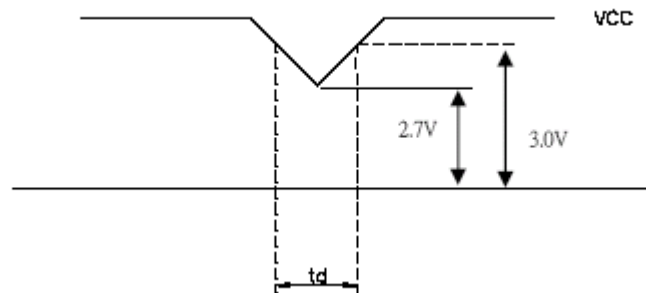

10.2 AC TIMING CHARACTERISTICS.

ITEM	SYMBOL	MIN.	TYP.	MAX.	UNIT	REMARK	
	t_{CPH}	33	40	43	ns		
Frequency	f_{CPH}	23	25	30	MHz		
Low Level width	t_{CWL}	6	-	-	ns		
High Level width	t_{CWH}	6	-	-	ns		
Rise Fall Time	t_{CLKr}, t_{CLKf}	-	-	3	ns		
Duty	-	0.45	0.50	0.55	-	Note1	
DE(Data Enable)	Setup Time	t_{DES}	5	-	-	ns	
	Hold Time	t_{DEH}	10	-	-	ns	
	Rise, Fall Time	t_{DEr}, t_{DEf}	-	-	16	ns	
	Horizontal Period	t_{HP}	750	800	900	t_{CLK}	
	Horizontal Valid	t_{HV}	640	640	640	t_{CLK}	
	Horizontal Blank	t_{HBK}	110	160	260	t_{CLK}	
	Vertical Period	t_{VP}	515	525	560	t_{HP}	
	Vertical Valid	t_{VW}	480	480	480	t_{HP}	
	Vertical Blank	t_{VBK}	35	45	80	t_{HP}	
	Vertical Frequency	f_V	55	60	65	Hz	
Data R,G,B	Setup Time	t_{DS}	5	-	-	ns	
	Hold Time	t_{DH}	10	-	-	ns	
	Rise, Fall Time	t_{DR}, t_{Df}	-	-	3	ns	

Note: (1)Clock Duty= t_{CLKL} / t_{CLK} .

10.3 DE MODE TIMING WAVEFORM

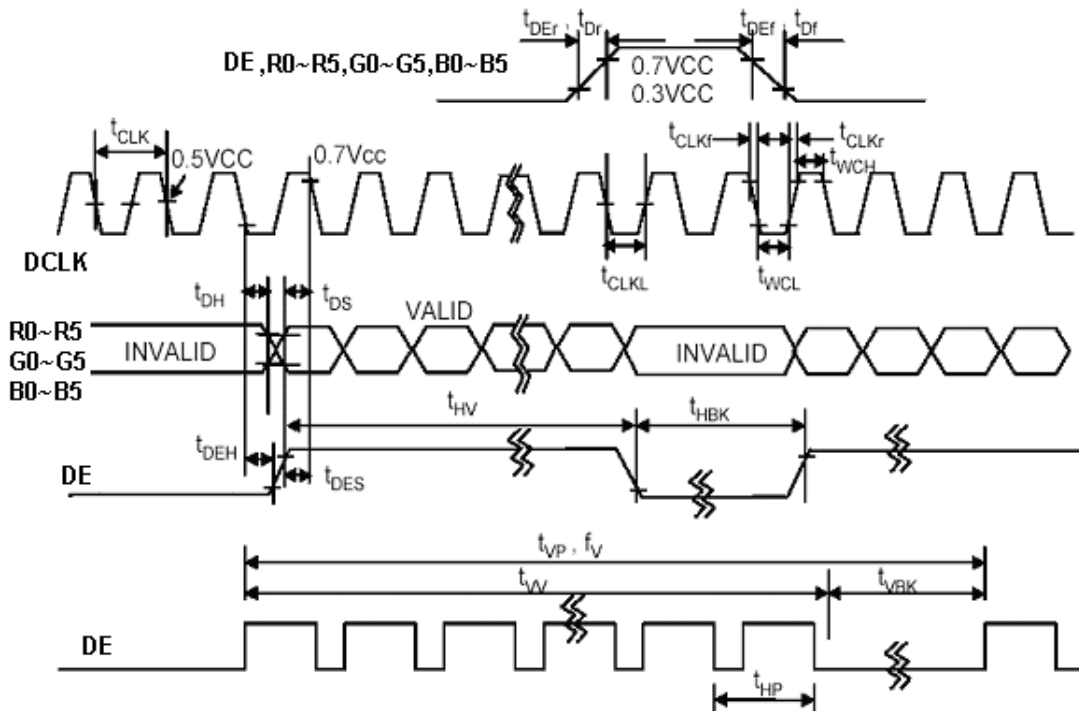

10.4 SYNC MODE INPUT SIGNAL CHARACTERISTICS

ITEM	SYMBOL	MIN.	TYP.	MAX.	UNIT	REMARK
Clock Period	t_{CLK}	33	40	43	ns	
Clock Frequency	f_{CLK}	23	25	30	MHz	
Clock Low Level width	t_{WCL}	6	-	-	ns	
Clock High Level width	t_{WCH}	6	-	-	ns	
Clock Rise Fall Time	t_{CLKr}, t_{CLKf}	-	-	3	ns	
HSYNC Period	t_{HP}	750	880	900	t_{CLK}	
HSYNC Pulse Width	t_{HW}	5	30		t_{CLK}	
HSYNC Front Porch	t_{HFP}	1	16	116	t_{CLK}	
HSYNC Back Porch	t_{HBP}	1	114	139	t_{CLK}	
HSYNC Width + Back Porch	$t_{HW} + t_{HBP}$	144	144	144	t_{CLK}	
Horizontal Blank	t_{HBK}	1	160	260	t_{CLK}	Note1
Horizontal Valid	t_{HV}	640	640	640	t_{CLK}	
VSYNC Period	t_{VP}	515	525	560	t_{HP}	
VSYNC Pulse Width	t_{VW}	1	3	5	t_{HP}	
VSYNC Front Porch	t_{VFP}	1	10	45	t_{HP}	
VSYNC Back Porch	t_{VBP}	30	32	34	t_{HP}	
VSYNC Width+Back Porch	$t_{VW} + t_{VBP}$	35	35	35	t_{CLK}	
Vertical Blank	t_{VBK}	35	45	80	t_{HP}	
Vertical data Width	t_W	480	480	480	t_{HP}	
Data Setup Time	t_{DS}	5	-	-	ns	
Hold Time	t_{DH}	10	-	-	ns	

Note: (1) $t_{HBK} = t_{HFP} + t_{HW} + t_{HBP}$

10.5 SYNC MODE TIMING WAVEFORM

10.5.1: Input vertical timing

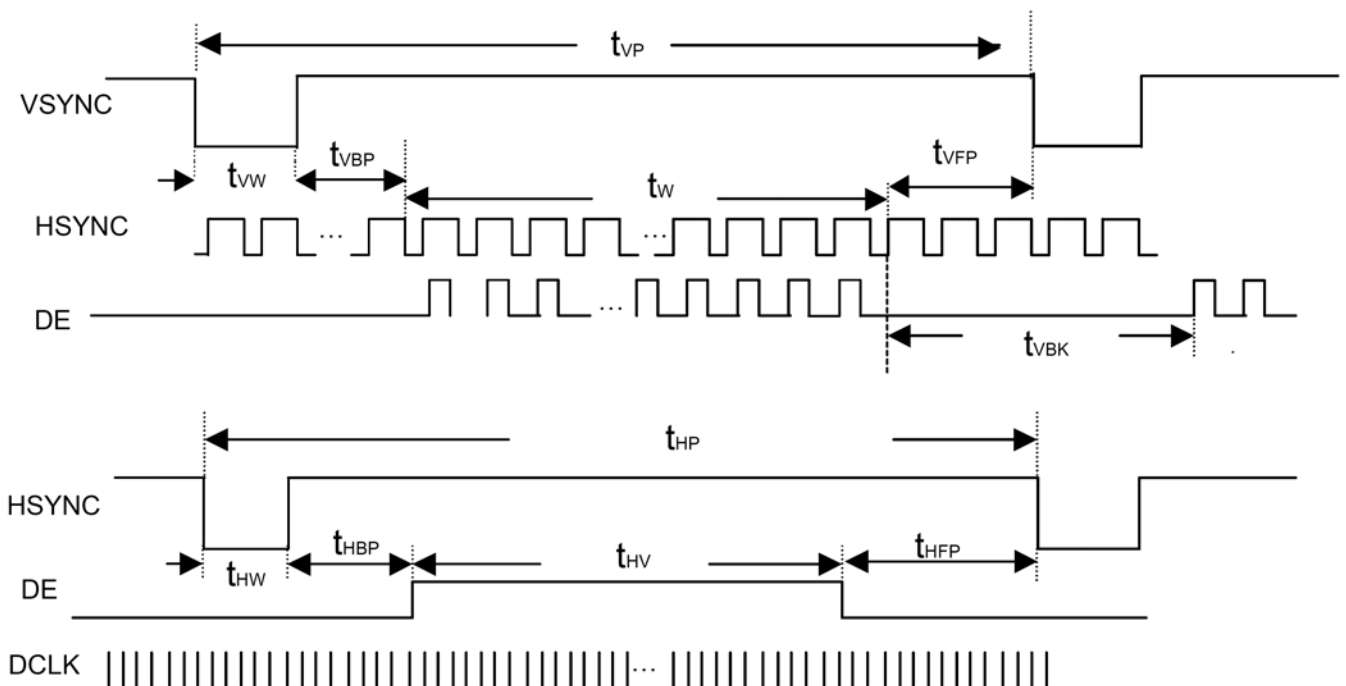

10.5.2 Input horizontal timing

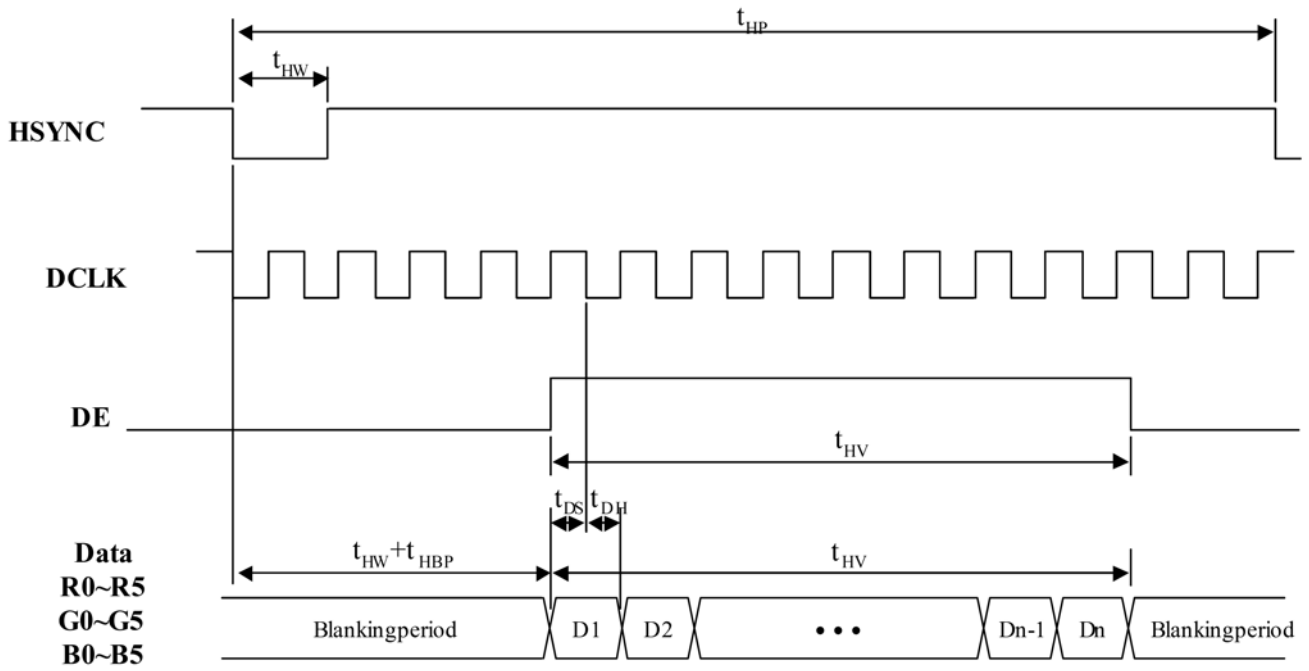

11. RELIABILITY TEST

ENVIRONMENTAL TEST				
NO.	ITEM	CONDITIONS	TIME PERIOD	REMARK
1	High Temperature Storage	80°C	240HRS	
2	Low Temperature Storage	-30°C	240HRS	
3	High Temperature Operation	70°C	240HRS	Note (2)
4	Low Temperature Operation	-20°C	240HRS	Note (2)
5	Temperature Cycle	-30°C (30min) ←25→ (5min) 80°C (30min)	200CYCLE	Note (2)
6	High Temperature Humidity Operation	60°C 90%RH	240HRS	Note (2)

Note (1): a. The module should work properly.

b. Before and after function test, the difference of consumptive current should be within 10%

Note (2): a. The module should work properly.

b. The module won't be deformed, color changeable or broken.

c. The modules can't be apart.

12. USE PRECAUTIONS

12.1. LIQUID CRYSTAL DISPLAY (LCD)

LCD is made up of glass, organic sealant, organic fluid, and polymer based polarizers. The following precautions should be taken when handling,

- (1). Keep the temperature within range of use and storage. Excessive temperature and humidity could cause polarization degradation, polarizer peel off or bubble.
- (2). Do not contact the exposed polarizers with anything harder than an HB pencil lead. To clean dust off the display surface, wipe gently with cotton, chamois or other soft material soaked in petroleum benzin.
- (3). Wipe off saliva or water drops immediately. Contact with water over a long period of time may cause polarizer deformation or color fading, while an active LCD with water condensation on its surface will cause corrosion of ITO electrodes.
- (4). Glass can be easily chipped or cracked from rough handling, especially at corners and edges.
- (5). Do not drive LCD with DC voltage.

12.2. Liquid Crystal Display Modules

12.2.1. Mechanical Considerations

LCM are assembled and adjusted with a high degree of precision. Avoid excessive shocks and do not make any alterations or modifications. The following should be noted.

- (1). Do not tamper in any way with the tabs on the metal frame.
- (2). Do not modify the PCB by drilling extra holes, changing its outline, moving its components or modifying its pattern.
- (3). Do not touch the elastomer connector, especially insert a backlight panel (for example, EL).
- (4). When mounting a LCM make sure that the PCB is not under any stress such as bending or twisting . Elastomer contacts are very delicate and missing pixels could result from slight dislocation of any of the elements.
- (5). Avoid pressing on the metal bezel, otherwise the elastomer connector could be deformed and lose contact, resulting in missing pixels.

12.2.2. Static Electricity

LCM contains CMOS LSI's and the same precaution for such devices should apply, namely

- (1). The operator should be grounded whenever he/she comes into contact with the module.
Never touch any of the conductive parts such as the LSI pads, the copper leads on the PCB and the interface terminals with any parts of the human body.
- (2). The modules should be kept in antistatic bags or other containers resistant to static for storage.
- (3). Only properly grounded soldering irons should be used.
- (4). If an electric screwdriver is used, it should be well grounded and shielded from commutator sparks.
- (5) The normal static prevention measures should be observed for work clothes and working benches; for the latter conductive (rubber) mat is recommended.

(6). Since dry air is inductive to statics, a relative humidity of 50-60% is recommended.

12.2.3. Soldering

- (1). Solder only to the I/O terminals.
- (2). Use only soldering irons with proper grounding and no leakage.
- (3). Soldering temperature : $280^{\circ}\text{C} \pm 10^{\circ}\text{C}$
- (4). Soldering time: 3 to 4 sec.
- (5). Use eutectic solder with resin flux fill.
- (6). If flux is used, the LCD surface should be covered to avoid flux spatters. Flux residue should be removed afterwards.

12.2.4. Operation

- (1). The viewing angle can be adjusted by varying the LCD driving voltage V_0 .
- (2). Driving voltage should be kept within specified range; excess voltage shortens display life.
- (3). Response time increases with decrease in temperature.
- (4). Display may turn black or dark blue at temperatures above its operational range; this is (however not pressing on the viewing area) may cause the segments to appear “fractured”.
- (5). Mechanical disturbance during operation (such as pressing on the viewing area) may cause the segments to appear “fractured”.

12.2.5. Storage

If any fluid leaks out of a damaged glass cell, wash off any human part that comes into contact with soap and water. Never swallow the fluid. The toxicity is extremely low but caution should be exercised at all the time.

12.2.6 Limited Warranty

Unless otherwise agreed between Chefree and customer, Chefree will replace or repair any of its LCD and LCM which is found to be defective electrically and visually when inspected in accordance with Chefree acceptance standards, for a period on one year from date of shipment. Confirmation of such date shall be based on freight documents. The warranty liability of Chefree is limited to repair and/or replacement on the terms set forth above. Chefree will not responsible for any subsequent or consequential events.