

CUSTOMER' S APPROVAL SPECIFICATIONS

MODEL: CH% \$=@ @001

(Complied with RoHS)



ISSUE:SEP.12.2013

Spec Condition:preliminary

NO.	ITEM	PAGE
1	COVER	--
2	RECORD OF REVISION	0-1
3	MECHANICAL SPECIFICATIONS	1
4	OUTLINE DIMENSIONS	2-3
5	INTERFACE PIN CONNECTION	4
6	BLOCK DIAGRAM	5
7	ABSOLUTE MAXIMUM RATINGS	5
8	ELECTRICAL CHARACTERISTICS	6-7
9	OPTICAL CHARACTERISTICS	7-9
10	TIMING SPECIFICATIONS	10-11
11	RELIABILITY TEST	12
12	PRECAUTIONS FOR USE	13

CUSTOMER	CHEFREE		
APPROVAL	APPROVAL	CHECKER	PREPARE
	<i>Joly</i>	<i>Joly</i>	<i>Jan</i>

2.RECORD OF REVISION

REV	DATE	PAGE	SUMMARY
0.1	2013.06.25	ALL	Preliminary specification was first issued.
0.2	2013.09.12	7	Modify Brightness, Power consumption and LED life-time.

3.MECHANICAL SPECIFICATIONS

(1)	Number Of Dots (Dots)	1024(R.G.B) X 768
(2)	Module Size(mm)	326.5(H) X 253.5(V) X 12(D)
(3)	Active Area(mm)	304.128(H) X 228.096(V)
(4)	Pixel Pitch(mm)	0.297 (H) X 0.297(V)
(5)	LCD / Polarizer Model	TFT , Transmissive, Normally/White
(6)	Backlight Color	White,LED
(7)	Viewing Direction	6 O'clock
(8)	Gray Scale Inversion Direction	12 O'clock
(9)	Electrical Interface	LVDS Interface
(10)	Color Configuration	R.G.B. Vertical Stripe
(11)	Module Weight(g)	930(Typ.) 960 (Max)

Note 1. Viewing direction for best image quality is different from TFT definition, there is the 180 degrees shift.



1	2	3	4
文件題目	圖號	頁	次頁
發行日	舊版日	登入號碼	機密等級

7		8 樣式 QT3-RD-E-0004-003	
No.	修定區塊	修訂內容	作成 修訂日期
		新版	Alan 2013.06.25

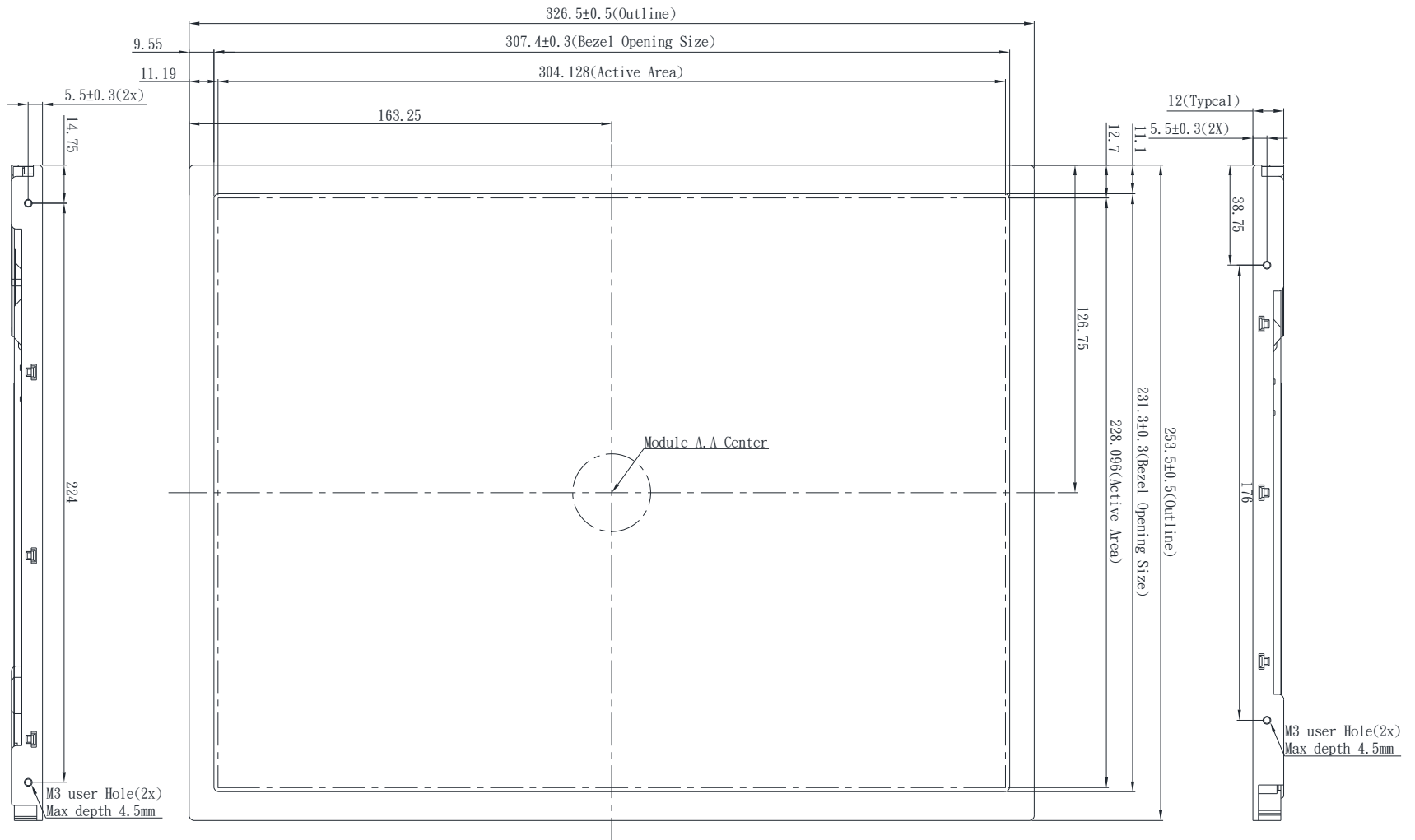

NOTE:

- Unit:mm
- Without Tolerance ± 0.3
- CN1:MSB240420HD or Compatible
- CN2:3808K-F05N-02R or Compatible

備考	單位:mm		投影法:	比例尺: 1:1
入庫	製圖 Alan	130625	名稱: CG' LCM	圖號 UZCGB[^X^?BEC
	審查			
	承認			

4. OUTLINE DIMENSIONS

A

B

C

D

E

F

1	2	3	4
文件題目	圖號	頁	次頁
發行日	舊版日	登入號碼	機密等級

7		8 樣式 QT3-RD-E-0004-003	
No.	修訂區塊	修訂內容	作成
		新版	Alan
			修訂日期
			2013.06.25

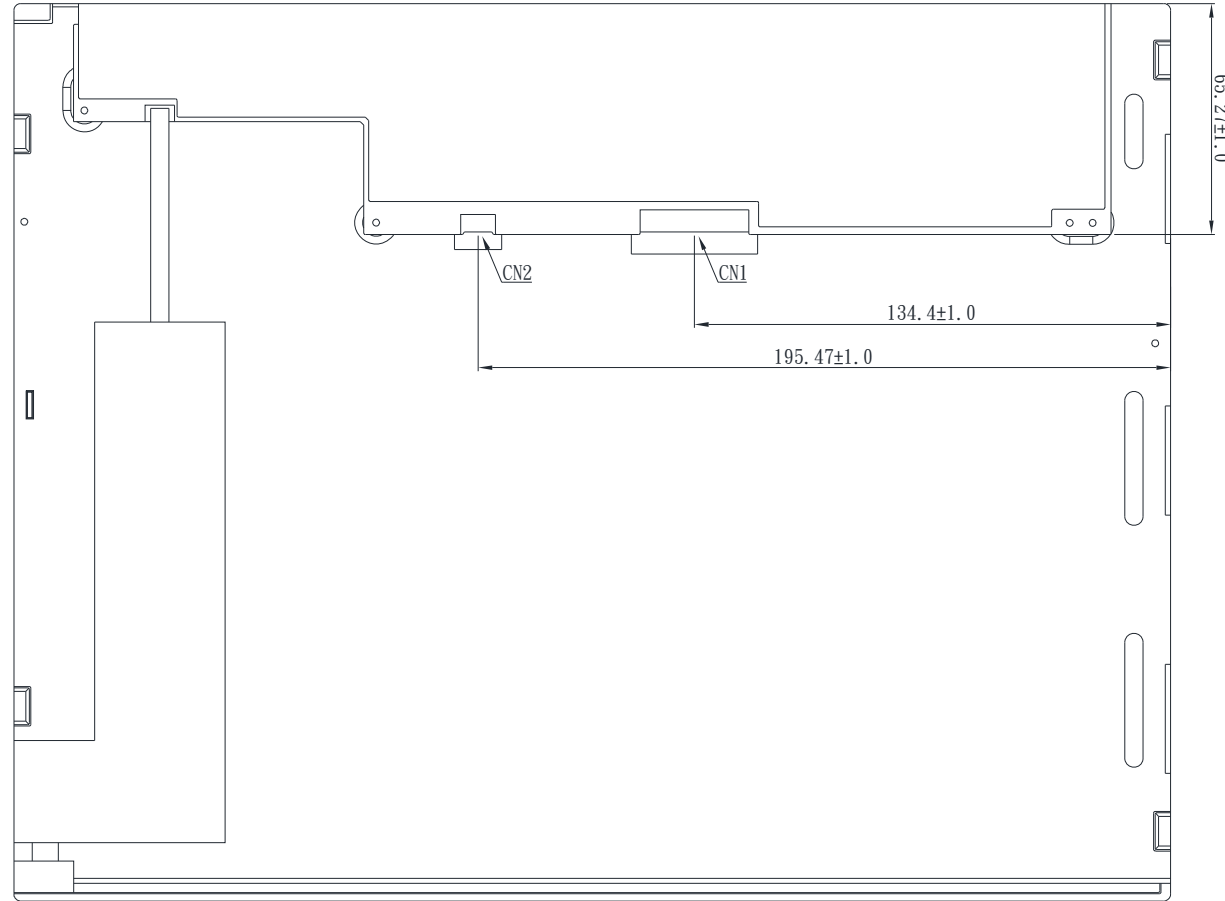

NOTE:
 1. Unit:mm
 2. Without Tolerance ±0.3
 3. CN1:MSB240420HD or Compatible
 4. CN2 : 3808K-F05N-02R or Compatible

備考	單位:mm		投影法:	比例尺: 1:1
入庫	製圖 Alan	130625	名稱: 15" LCM	圖號 CH1501LFL-001
	審查			
	承認			

5. INTERFACE PIN CONNECTION

5.1 LCM PANEL DRIVING SECTION

Connector: MSB240420HD or Equivalent

PIN NO.	SYMBOL	FUNCTION	REMARK
1	VDD	Power Supply, 3.3V (typical)	
2	VDD	Power Supply, 3.3V (typical)	
3	VSS	Ground	
4	REV	Reverse Scan selection	Note 1
5	Rin1-	-LVDS differential data input	
6	Rin1+	+LVDS differential data input	
7	VSS	Ground	
8	Rin2-	-LVDS differential data input	
9	Rin2+	+LVDS differential data input	
10	VSS	Ground	
11	Rin3-	-LVDS differential data input	
12	Rin3+	+LVDS differential data input	
13	VSS	Ground	
14	ClkIN-	-LVDS differential clock input	
15	ClkIN+	+LVDS differential clock input	
16	VSS	Ground	
17	Rin4-	-LVDS differential data input	
18	Rin4+	+LVDS differential data input	
19	VSS	Ground	
20	NC	Not connect	

Note 1: I REV = LOW/NC

Gate Scan :

Y1→Y2→Y3

Y1 : G1→G2- - - -→G258

Source Scan :

X1→X2→X3→X4→X5

X1: S1→S2- - - -→S600

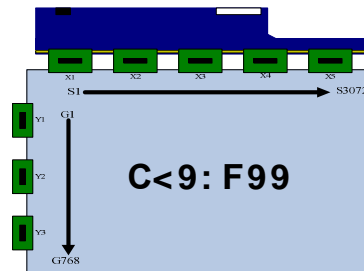

II REV = High

Gate Scan :

Y3→Y2→Y1

Y1 : G258→G257- - - -→G1

Source Scan :

X5→X4→X3→X2→X1

X1: S600→S599- - - -→S1

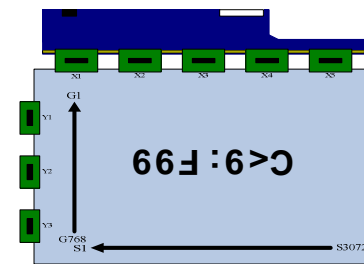

5.2 LED INTERFACE CONNECTOR

Connector: 3808K-F05N-02R or Equivalent

PIN NO.	SYMBOL	FUNCTION	REMARK
1	VCC	12V	
2	GND	GND	
3	Enable	5V-On / 0V-Off	
4	Dimming	PWM Dimming or Analog Dimming	
5	NC	Not connect	

6. BLOCK DIAGRAM

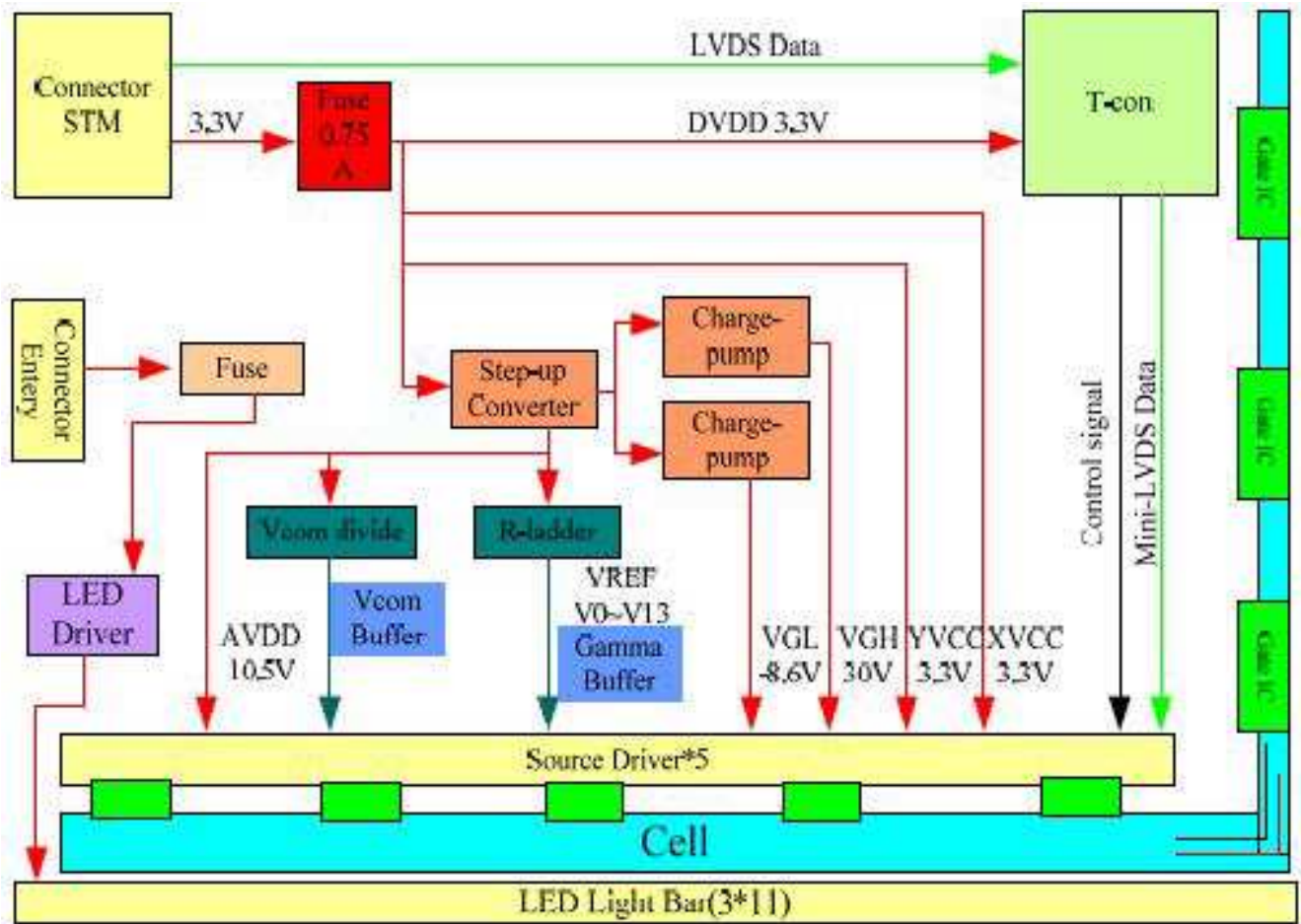

7. ABSOLUTE MAXIMUM RATINGS

7.1 ELECTRICAL ABSOLUTE MAXIMUM RATINGS

ITEM	SYMBOL	MIN.	MAX.	UNIT	REMARK
Power Voltage	VDD	-0.5	5	V	

7.2 ENVIRONMENTAL ABSOLUTE MAXIMUM RATINGS

ITEM	OPERATING		STORAGE		REMARK
	MIN.	MAX.	MIN.	MAX.	
Ambient Temperature(°C)	-20	70	-30	80	Note 1,2,3
Humidity(% RH)	10	85	10	95	Note 4

Note 1 : The response time will become lower when operated at low temperature.

Note 2 : Background color changes slightly depending on ambient temperature.

Note 3 : Operation $T_a=70^\circ\text{C}$ & $-20^\circ\text{C} \leq 240\text{Hrs}$.

Note 4 : Operation $T_a=50^\circ\text{C}$ & $\text{RH}=85\% \leq 240\text{Hrs}$.

Note 5 : Please make sure to keep the temperature of LCD module is less than 70°C

8.ELECTRICAL CHARACTERISTICS

8.1 ELECTRICAL CHARACTERISTICS OF LCD

Ta=25°C

ITEM	SYMBOL	MIN.	TYP.	MAX.	UNIT	REMARK
Power Voltage For LCD	VDD	3.0	3.3	3.6	V	-
	IDD	-	250	300	mA	3.3V/Black pattern
	PDD	-	-	1.3	W	Black Pattern, 60Hz
	Irush	-	-	0.75	A	Note1
	VDDrp	-	-	200	[mV]p-p	Note2

Note 1: Measure Condition

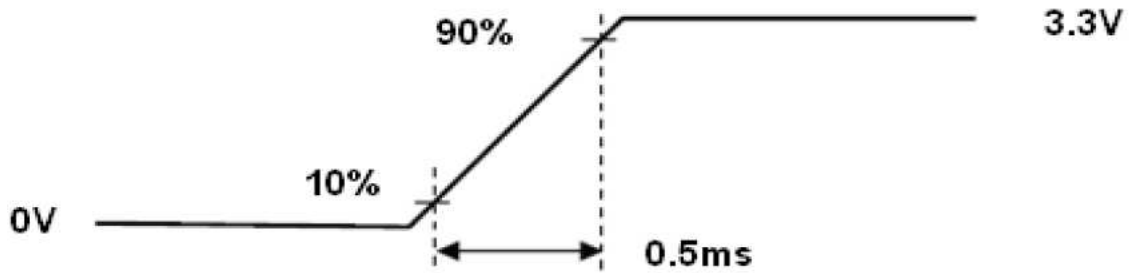

VDD rising time

Note 2: VDD Power Dip Condition

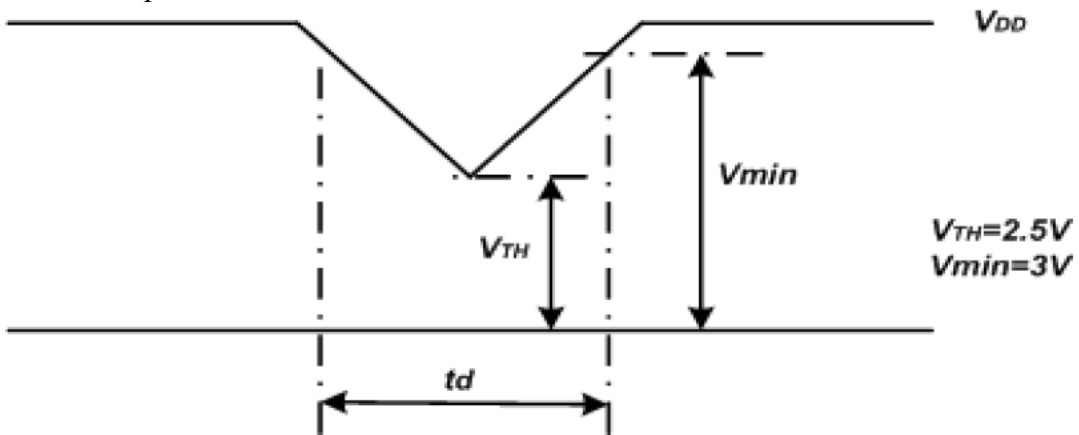

If $V_{TH} < V_{DD} \leq V_{min}$, then $t_d \leq 10ms$; When the voltage return to normal our panel must revive automatically.

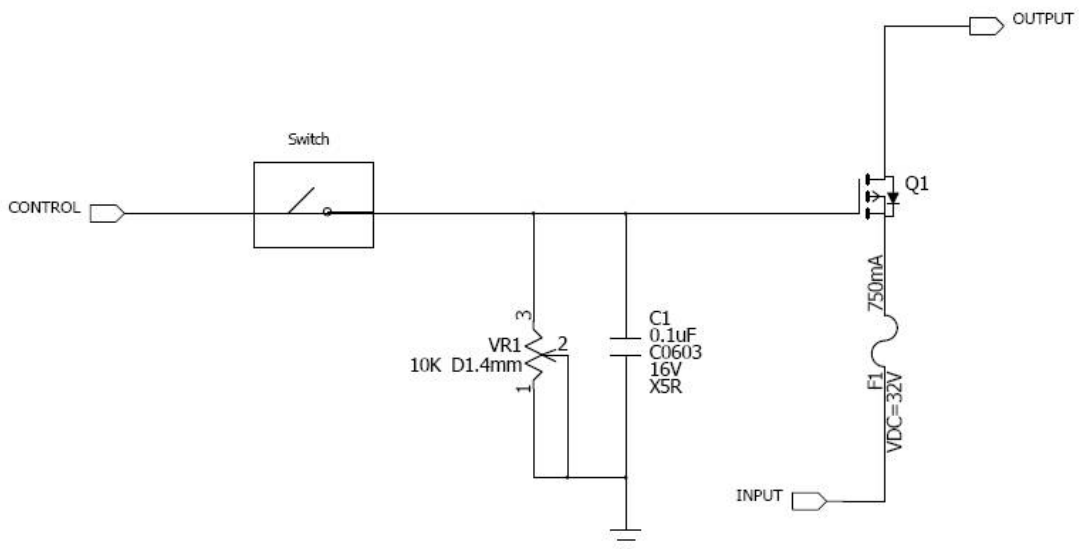

8.2 BACKLIGHT CHARACTERISTICS

Ta=25°C

ITEM	SYMBOL	MIN.	TYP.	MAX.	UNIT	REMARK	
LED Input	VLED	10.8	12	12.6	V	Note 2	
LED Power Consumption	PLED	-	-	7.5	W	Note 2	
PWM Signal Voltage	VLED_PWM	High	4.5	5	5.5	V	-
		Low	-	-	0.8	V	-
PWM dimming Frequency	FPWM	200	-	20K	Hz	Ddim ≥ 5°C	
LED Enable Voltage	VLED_EN	High	2.0	5	5.5	V	-
		Low	-	-	0.8	V	-
LED Life Time	LT	50,000	-	-	Hours	Note 1	

Note 1: The LED life time define as the estimated time to 50% degradation of initial luminous.

Note 2: A higher LED power supply voltage will result in better power efficiency. Keep the VLED between 12V and 12.6V is strongly recommended.

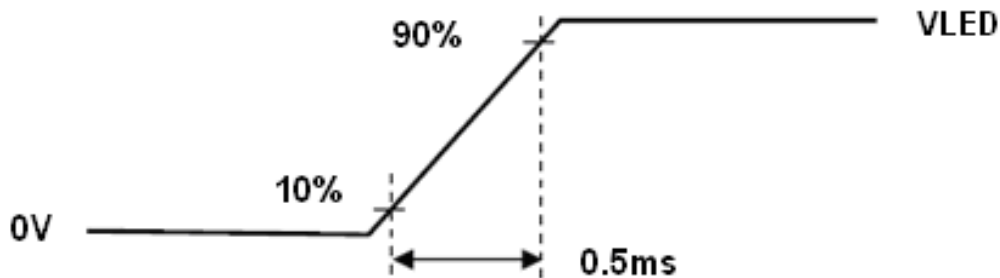

VLED rising time

9.OPTICAL CHARACTERISTICS

Ta=25°C

ITEM	SYMBOL	CONDITIONS	MIN.	TYP.	MAX.	UNIT	REMARK
Contrast Ratio	CR		450	800	-	-	Note (1)
Response Time	TR		-	-	-	ms	Note (2)
	TF		-	-	-	ms	
	TR+TF		-	16	-	ms	
Chromaticity	White	Wx	0.255	0.305	0.355	-	Note (4)
		Wy	0.275	0.325	0.375	-	
	Red	Rx	0.601	0.631	0.661	-	
		Ry	0.324	0.354	0.384	-	
	Green	Gx	0.288	0.318	0.348	-	
		Gy	0.600	0.630	0.660	-	
	Blue	Bx	0.117	0.147	0.177	-	
		By	0.045	0.075	0.105	-	
Viewing Angle	Hor.	Θx+	70	80	-	Deg.	Note (3)
		Θx-	70	80	-		
	Ver.	Θy+	70	80	-		
		Θy-	60	70	-		
Luminance	L	PWM=100%	(320)	400	-	cd/m2	
Uniformity			75	80		%	Note (5)

*Note (1) Definition of Contrast Ratio (CR):

The contrast ratio can be calculated by the following expression.

$$\text{Contrast Ratio (CR)} = L_{63} / L_0$$

L63: Luminance of gray level 63

L 0: Luminance of gray level 0

$$\text{CR} = \text{CR} (5)$$

CR (X) is corresponding to the Contrast Ratio of the point X at Figure in Note (5).

*Note (2) Definition of Response Time (T_R , T_F):

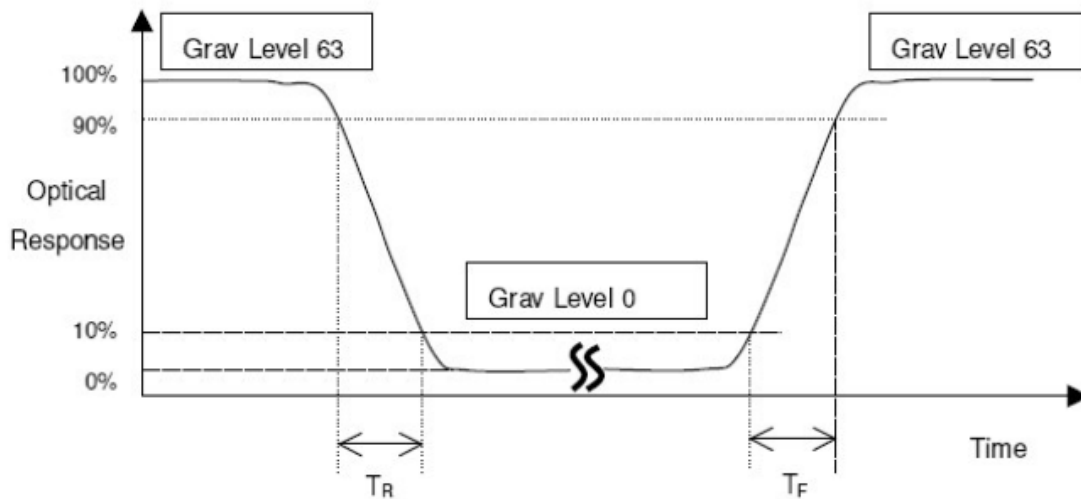

*Note(3) Definition of Viewing Angle

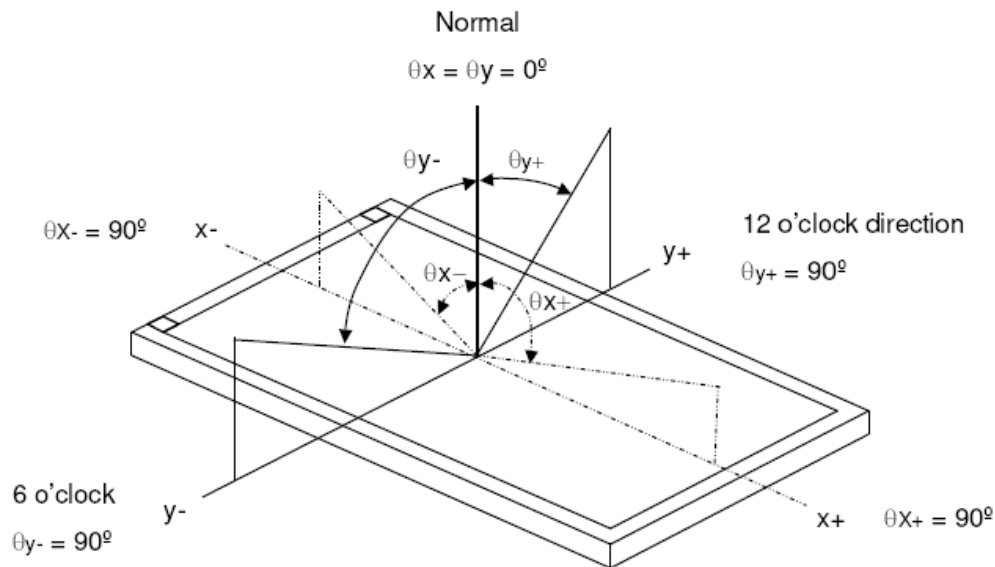

*Note (4) Measurement Set-Up:

The LCD module should be stabilized at a given temperature for 20 minutes to avoid abrupt temperature change during measuring. In order to stabilize the luminance, the measurement should be executed after lighting Backlight for 20 minutes in a windless room.

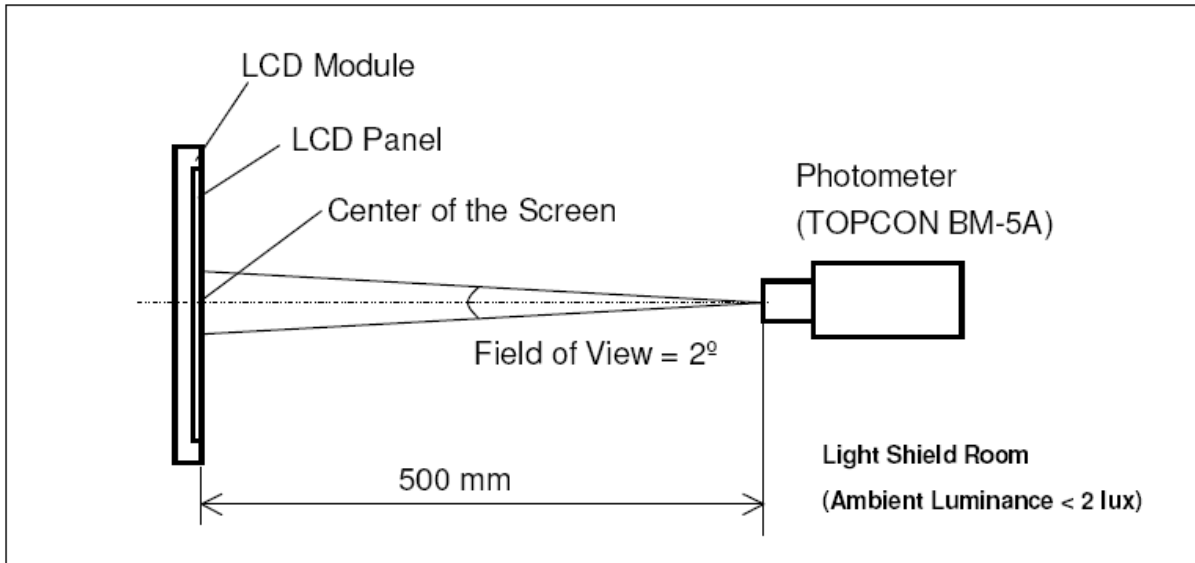

*Note (5)

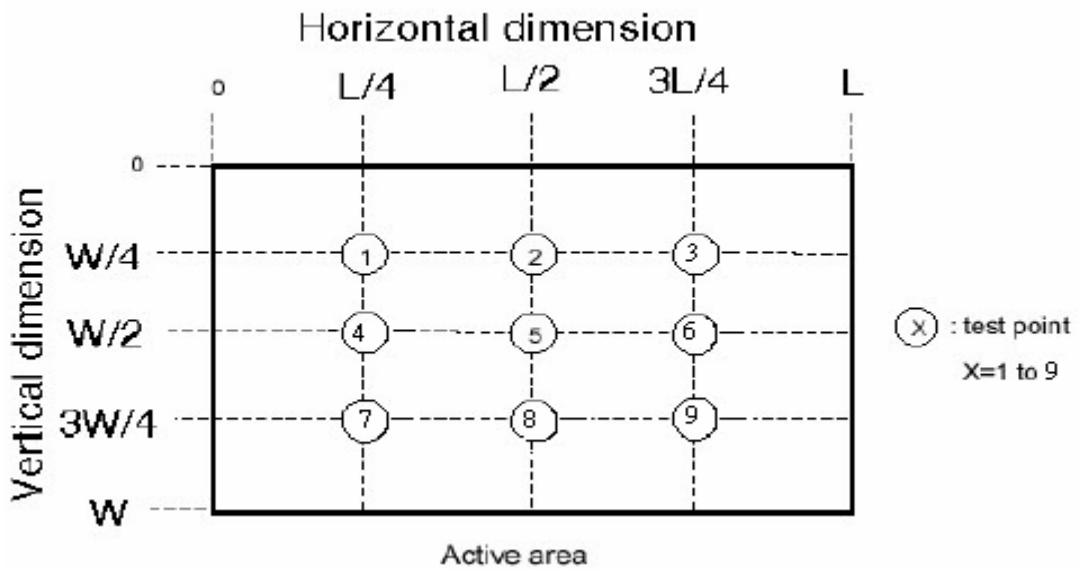

$$\left(1 - \frac{\text{MAX Luminance} - \text{Average Luminance}}{\text{Average Luminance}} \right) \times 100\% > 75\%$$

10. TIMING SPECIFICATIONS

10.1 POWER SIGNAL SEQUENCE

VDD power on/off sequence is as follows. Interface signals are also shown in the chart. Signals from any system shall be Hi-Z state or low level when VDD is off. a. Power on sequence:

Power Sequence

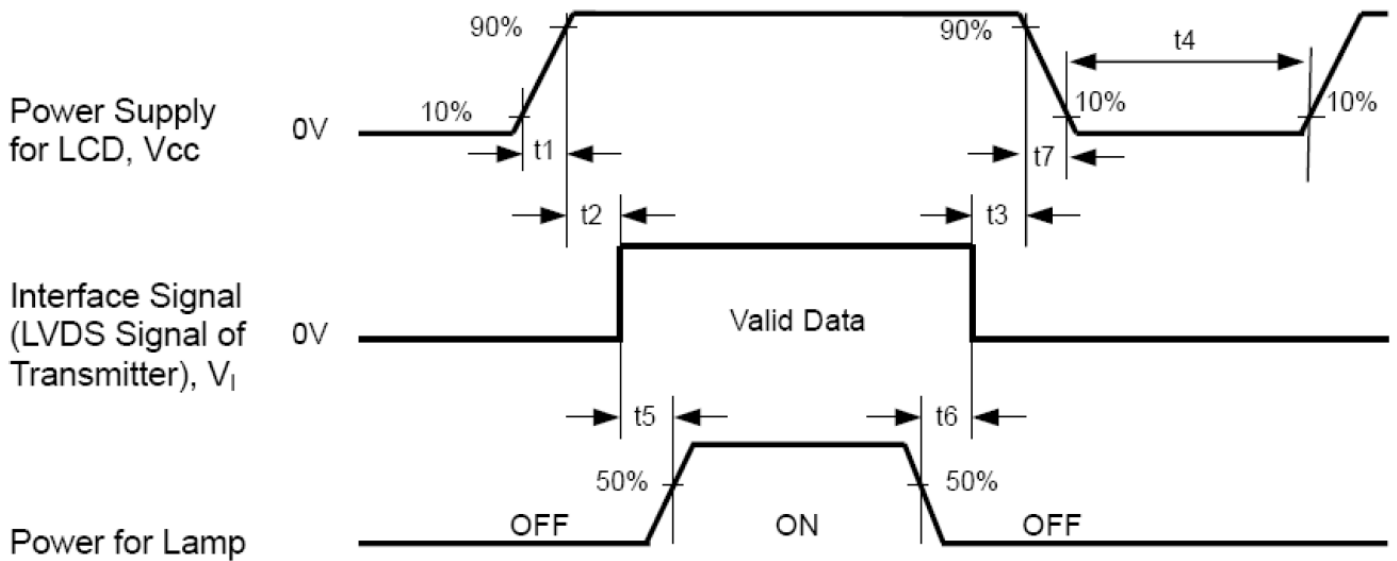

Power Sequencing Requirements

ITEM	SYMBOL	MIN.	TYP.	MAX.	UNIT	REMARK
VDD Rise Time	t1	0.02	-	10	ms	
VDD Good to Signal Valid	t2	0	-	20	ms	
Signal Disable to Power Down	t3	0	-	1000	ms	
Power Off	t4	1000	-		ms	
Signal Valid to Backlight On	t5	300	-		ms	
Backlight Off to Signal Disable	t6	200	-		ms	
VDD Fall Time	t7	0	-	100	ms	

10.2 TIMING CHARACTERISTICS

10.2.1. Interface Timings

Synchronization Method : DE only

ITEM	SYMBOL	MIN.	TYP.	MAX.	UNIT	REMARK
LVDS Clock Frequency <single >	fdck	50	65	80	MHz	
H Total Time	Thp	1056	1344	1720	clocks	
H Active Time	HA	1024	1024	1024	clocks	
H Front Porch	Thfp	-	48	-	clocks	
H Sync Pulse Width	HSPW	-	32	-	clocks	
H Back Porch	Thbp	-	240	-	clocks	
H Frequency	fh	46.32	48.36	59.40	kHz	
V Total Time	Tvp	772	806	990	lines	
V Active Time	VA	768	768	768	lines	
V Front Porch	Tvfp	-	3	-	lines	
V Sync Pulse Width	VSPW	-	12	-	lines	
V Back Porch	Tvbp	-	23	-	lines	
V Frequency	fv		60		Hz	

Note: H Blank area and V Blank area can not be changed at every frame

10.2.2. Timing Diagram of Interface Signal

Timing Characteristics

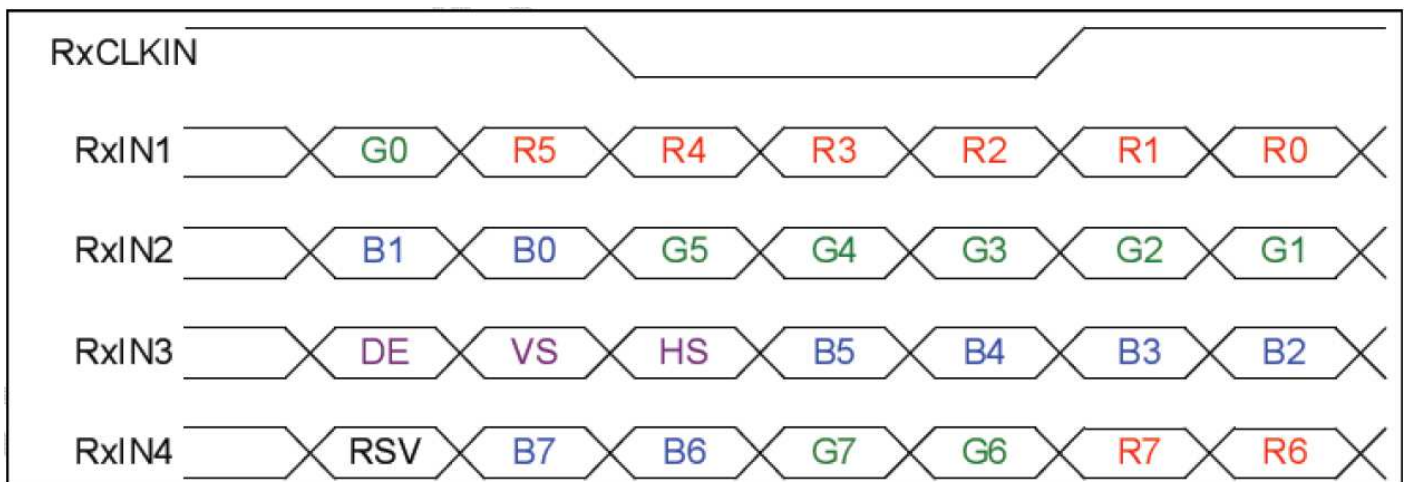

Note1 : Follow SPWG

Note2 : R/G/B data7 : MSB , R/G/B data0 : LSB

11. RELIABILITY TEST

Ta = 25°C

ENVIRONMENTAL TEST				
NO.	ITEM	CONDITIONS	TIME PERIOD	REMARK
1	High Temperature Storage	80°C	240HRS	
2	Low Temperature Storage	-30±3°C	240HRS	
3	High Temperature Operation	70°C	240HRS	
4	Low Temperature Operation	-20°C	240HRS	
5	Temperature Cycle	-20°C ← 25°C → 70°C (30min) (5min) (30min)	100CYCLE	
6	High Temperature Humidity Operation	50°C 85%RH	240HRS	

NOTE (1): a. THE MODULE SHOULD WORK PROPERLY.

b. BEFORE AND AFTER FUNCTION TEST, THE DIFFERENCE OF CONSUMPTIVE CURRENT SHOULD BE WITHIN 10%

NOTE (2) : a. THE MODULE SHOULD WORK PROPERLY.

b. THE MODLUE WON'T BE DEFORMATIVE, COLOR CHANGEABLE OR BROKEN.

c. THE MODULES CAN'T BE APART.

12. PRECAUTIONS FOR USE

12.1 Safety

- (1) Do not swallow any liquid crystal, even if there is no proof that liquid crystal is poisonous.
- (2) If the LCD panel breaks, be careful not to get liquid crystal to touch your skin.
- (3) If skin is exposed to liquid crystal, wash the area thoroughly with alcohol or soap.

12.2 Storage Conditions

- (1) Store the panel or module in a dark place where the temperature is $23\pm 5^{\circ}\text{C}$ and the humidity is below $50\pm 20\%\text{RH}$.
- (2) Store in anti-static electricity container.
- (3) Store in clean environment, free from dust, active gas, and solvent.
- (4) Do not place the module near organics solvents or corrosive gases.
- (5) Do not crush, shake, or jolt the module.

12.3 Handling Precautions

- (1) Avoid static electricity which can damage the CMOS LSI.
- (2) The polarizing plate of the display is very fragile. So, please handle it very carefully.
- (3) Do not give external shock.
- (4) Do not apply excessive force on the surface.
- (5) Do not wipe the polarizing plate with a dry cloth, as it may easily scratch the Surface of plate.
- (6) Do not use ketonics solvent & Aromatic solvent, use with a soft cloth soaked with a cleaning naphtha solvent.
- (7) Do not operate it above the absolute maximum rating.
- (8) Do not remove the panel or frame from the module.
- (9) When the module is assembled, it should be attached to the system firmly, Be careful not to twist and bend the module.
- (10) Wipe off water droplets or oil immediately . If you leave the droplets for a long time, staining and discoloration may occur.
- (11) If the liquid crystal material leaks from the panel, it should be kept away from the eyes or mouth. In case of contact with hands, legs or clothes, it must be washed away thoroughly with soap.

12.4 Warranty

(1) Acceptance inspection period

The period is within one month after the arrival of contracted commodity at the buyer's factory site.

(2) Applicable warrant period

The period is within 12 months since the date of shipping out under normal using and storage conditions.