

A Brighter Solution

AMP DISPLAY INC.

Distributed by:



SPECIFICATIONS

4.3-in COLOR TFT MODULE

CUSTOMER:	
CUSTOMER PART NO.	
AMP DISPLAY PART NO.	AM480272E %HNQW-T0\$ <
APPROVED BY:	
DATE:	

APPROVED FOR SPECIFICATIONS

APPROVED FOR SPECIFICATION AND PROTOTYPES

AMP DISPLAY INC

9856 SIXTH STREET RANCHO CUCAMONGA CA 91730
TEL: 909-980-13410 FAX: 909-980-1419
WWW.AMPDISPLAY.COM

DISTRIBUTED BY TEXIM EUROPE

RECORD OF REVISION

Revision Date	Page	Contents	Editor
2011/06/28	--	New Release	Rober
2011/09/05	4	Redefine Operation & Storage Temperature	Rober
2011/09/30	30	Update OUTLINE DIMENSION	Rober
2012/3/19	8	Correct .BLOCK DIAGRAM	Rober

DISTRIBUTED BY TEXIM EUROPE

1. INTRODUCTION

This is a color active matrix TFT-LCD that uses amorphous silicon TFT as a switching device . This model is composed of a 4.3inch TFT-LCD panel, a driving circuit, Capacitive touch panel and LED backlight system. This TFT-LCD has a high resolution (480(R.G.B) X 272) and can display up to 262,144 colors.

1-1. Features

- (1) Construction : a-Si TFT-LCD with driving system, White LED Backlight.
- (2) LCD type :Normally Black,MVA
- (3) Number of the Colors : 262,144 colors (R,G,B 6 bit digital each)
- (4) RGB Interface 40 pin.
- (5) LCD Power Supply Voltage : 3.3V single power input,
- (6) Capacitive touch panel

2. PHYSICAL SPECIFICATIONS

Item	Specifications	unit
Display resolution(dot)	480RGB (W) x 272(H)	dots
Display area	95.04 (W) x 53.856 (H)	mm
Pixel pitch	0.198 (W) x 0.198 (H)	mm
Color configuration	R.G.B Vertical stripe	
Overall dimension	68.2 (W) x 105.5 (H)x6.71(T)	mm
Surface treatment	Antiglare , Hard-Coating(3H)	
Brightness	450	cd/m ²
Contrast ratio	500 : 1	
Backlight unit	LED	
Display color	262,144	colors
Display Mode	Normally Black	

DISTRIBUTED BY TEXIM EUROPE

3. ABSOLUTE MAXIMUM RATINGS

ITEM	SYMBOL	MIN	MAX	UNIT	NOTE
Power Supply Voltage	V _{cc}	-0.5	5	V	
Led Supply Voltage	V _{LED}	--	6	V	
Signal Input Voltage	DCLK , DE R0~R5 G0~G5 B0~B5	-0.5	V _{cc} + 0.5	V	
Operation Temperature	Top	-20	70	°C	(1)
Storage Temperature	Tstg	-30	80	°C	(1)

4. ELECTRICAL CHARACTERISTICS

4-1 TFT LCD Module voltage

ITEM	SYMBOL	MIN	TYP	MAX	UNIT	NOTE
Power Voltage For LCD	V _{CC}	3.0	3.3	3.6	V	(1)
Power Voltage For VLED	V _{DD}	--	5.0	--	V	
Logic Input Voltage	V _{IH}	V _{CC} *0.7	--	V _{CC}	V	
	V _{IL}	0	--	V _{CC} *0.3	V	
ADJ Input Voltage	V _{IH}	3.0	--	5.0	V	
	V _{IL}	GND	--	0.3	V	

4-2 TFT LCD current consumption

ITEM	SYMBOL	MIN	TYP	MAX	UNIT	NOTE
LCD Power Current	I _{cc}	-	75	-	mA	(1)
LED Power Current	I _{LED} (V _{LED} =5V)	-	130	-	mA	(2)

NOTE : (1) Typ : under 64 gray pattern Max : under white pattern



(a) 64 Gray Pattern



(b) White Pattern

(2) Typ : When V_{LED} is 5.0V Max : When V_{LED} is 4.5V

Note: The data is reference only

DISTRIBUTED BY TEXIM EUROPE

4-3 Backlight Driving Conditions

Parameter	Symbol	Min.	Typ.	Max.	Unit	Condition
LED voltage	V_{AK}	--	23.1	--	V	$I_{LED}=20mA, T_a=25^{\circ}C$
LED forward current	I_{LED}	--	20	--	mA	$T_a=25^{\circ}C$
	I_{LED}	--	15	--	mA	$T_a=60^{\circ}C$

Note 1 : The LED Supply Voltage is defined by the number of LED at $T_a=25^{\circ}C$ and $I_L=74mA$.

Note 2 : The "LED life time" is defined as the module brightness decrease to 50% original brightness at $T_a=25^{\circ}C$ and $I_L=74mA$. The LED lifetime could be decreased if operating I_L is larger than 74mA.

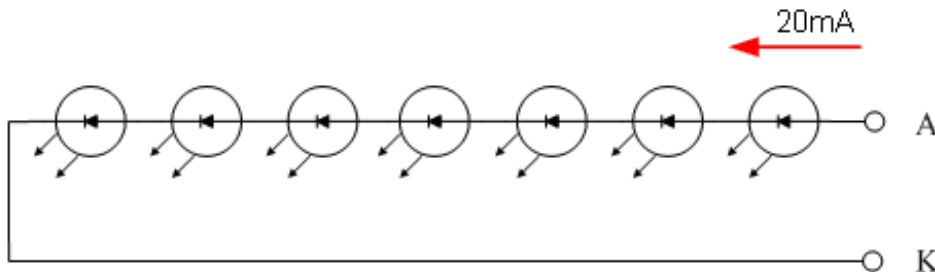

Note 3 : When LCM is operated over $40^{\circ}C$ ambient temperature, the I_{LED} should be follow :

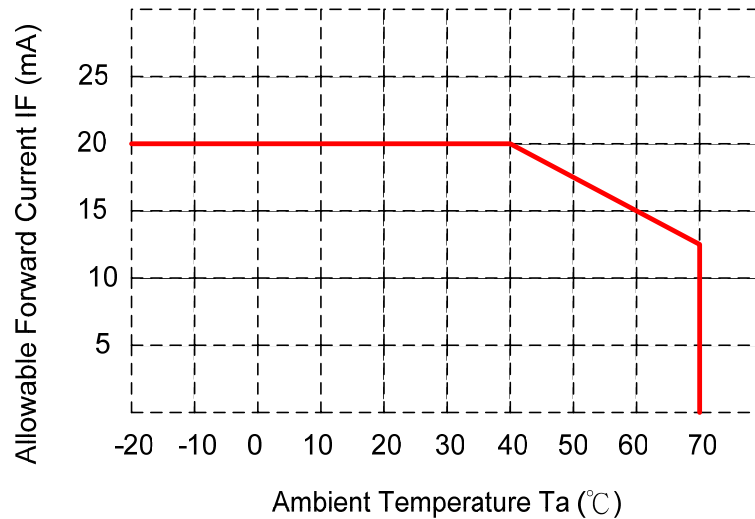

5. INTERFACE

5.1 TFT INTERFACE

Pin No	Symbol	Function
1	U/D	Up or Down Display Control
2	(NC)	No connection
3	Hsync(NC)	Horizontal SYNC. (Sync mode used)
4	VLED	Power Supply for LED
5	VLED	Power Supply for LED
6	VLED	Power Supply for LED
7	Vcc	Power Supply for LCD
8	Vsync(NC)	Vertical SYNC. (Sync mode used)
9	DE	Data Enable
10	Vss	Power Ground
11	Vss	Power Ground
12	ADJ	Adjust for LED Brightness
13	B5	Blue Data 5 (MSB)
14	B4	Blue Data 4
15	B3	Blue Data 3
16	Vss	Power Ground
17	B2	Blue Data 2
18	B1	Blue Data 1
19	B0	Blue Data 0 (LSB)
20	Vss	Power Ground
21	G5	Green Data 5 (MSB)
22	G4	Green Data 4
23	G3	Green Data 3
24	Vss	Power Ground
25	G2	Green Data 2
26	G1	Green Data 1
27	G0	Green Data 0 (LSB)
28	Vss	Power Ground
29	R5	Red Data 5 (MSB)
30	R4	Red Data 4
31	R3	Red Data 3
32	Vss	Power Ground
33	R2	Red Data 2
34	R1	Red Data 1
35	R0	Red Data 0 (LSB)
36	Vss	Power Ground
37	Vss	Power Ground
38	DCLK	Clock Signals
39	Vss	Power Ground
40	L/R	Left or Right Display Control

Connector Part NO: STARCONN 089H40-000000-G2-C or equivalent

DISTRIBUTED BY TEXIM EUROPE

5.2 Capacitive Touch Panel FPC Descriptions

No.	Symbol	I/O	Description	Remark
1.	GND	-	Ground.(0V)	
2.	SDA	I/O	I2C Interface.	
3.	SCL	I		
4.	VDD	-	Power Supply for TP controller.(3.3V)	
5.	INT	O	IRQ Terminal.	
6.	XRES	I	Terminal of Reset TP controller.	

Connector Part NO: STARCONN 089H06-000000-G2-R or equivalent.

NOTE :

- ADJ adjust brightness to control Pin , Pulse duty the bigger the brighter.

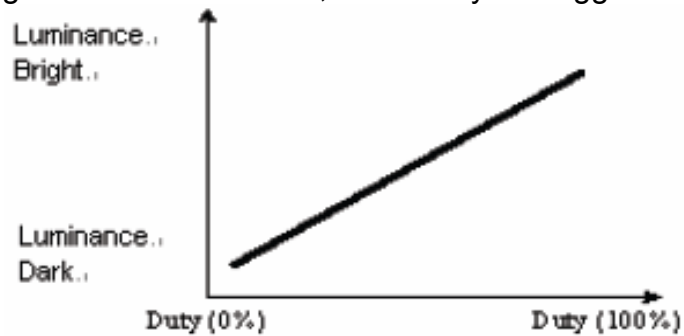

- ADJ signal = 0 ~ 5.0V , operation frequency : 300Hz~1KHz

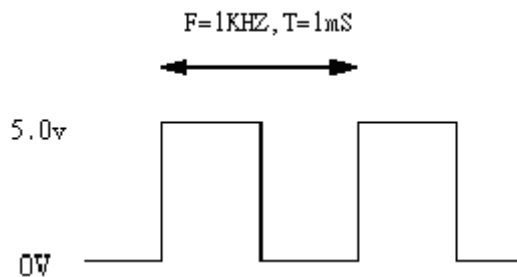

- VSS Pin must ground contact, can not be floating.

Note: The data is reference only

DISTRIBUTED BY TEXIM EUROPE

6. BLOCK DIAGRAM

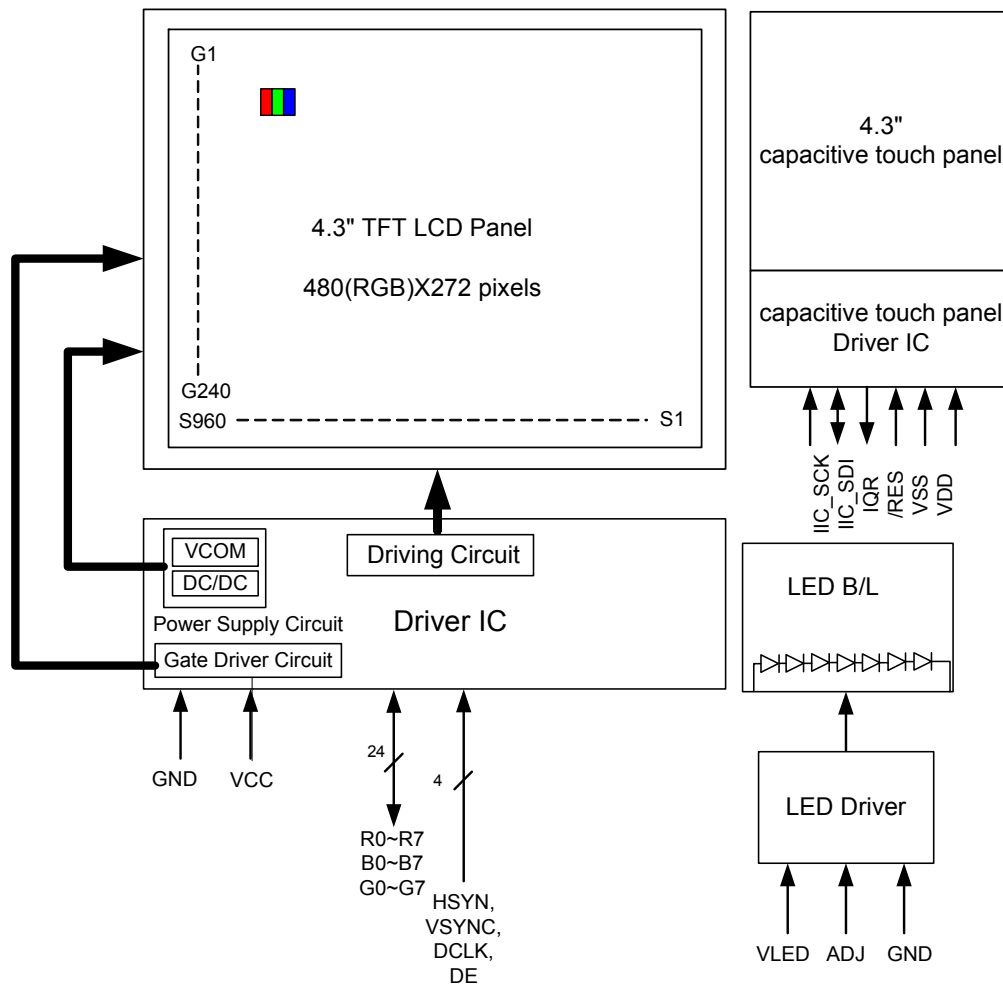

DISTRIBUTED BY TEXIM EUROPE

7. INPUT SIGNAL :

7-1 Timing Specification.

Item	Symbol	Min.	Typ.	Max.	Unit		
DCLK Frequency	Fclk	5	9	12	MHz		
DCLK Period	Tclk	83	110	200	ns		
Hsync	Period Time	Th	490	531	605	DCLK	
	Display Period	Thdisp		480		DCLK	
	Back Porch	Thbp	8	43		DCLK	By H_BLANKING setting
	Front Porch	Thfp	2	8		DCLK	
	Pulse Width	Thw	1			DCLK	
Vsync	Period Time	Tv	275	288	335	H	
	Display Period	Tvdisp		272		H	
	Back Porch	Tvbp	2	12		H	By V_BLANKING setting
	Front Porch	Tvfp	1	4		H	
	Pulse Width	Tvw	1	10		H	

7-2 Timing chart

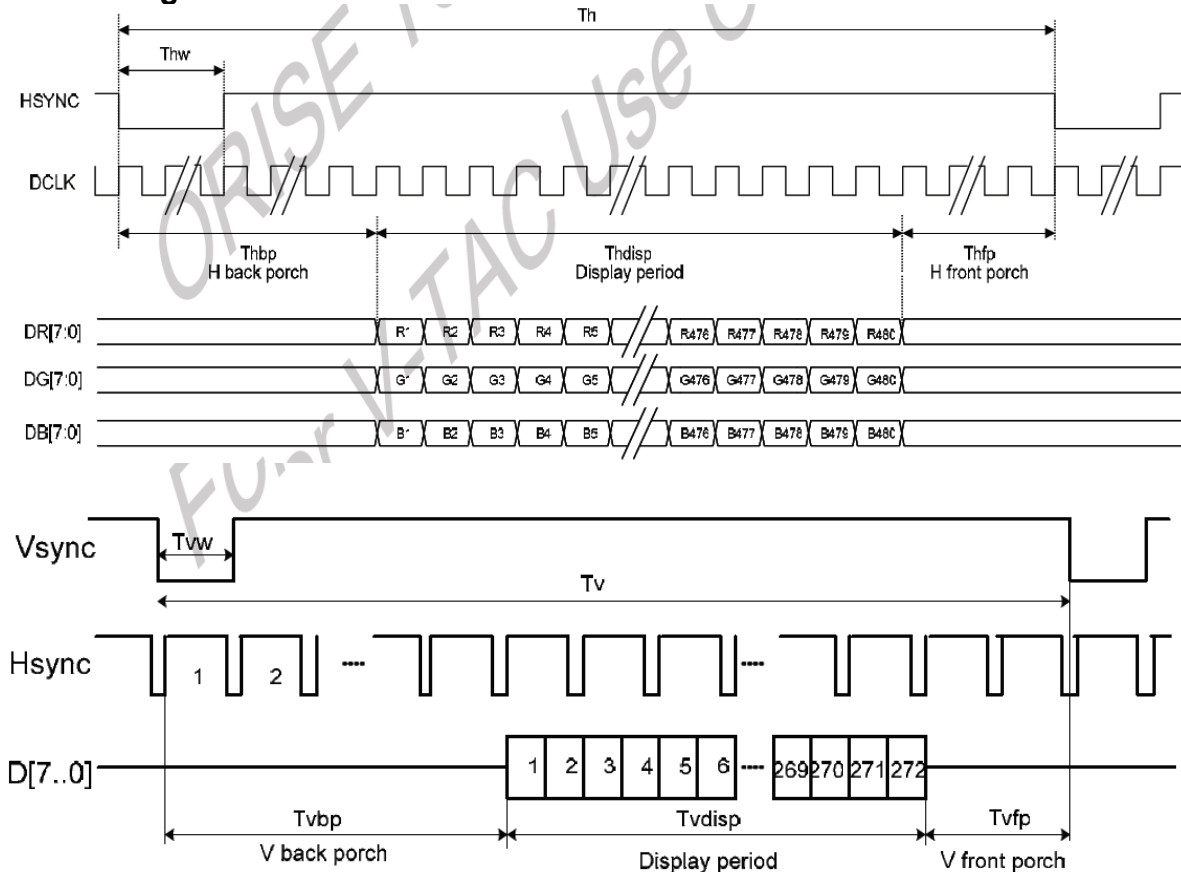

DISTRIBUTED BY TEXIM EUROPE

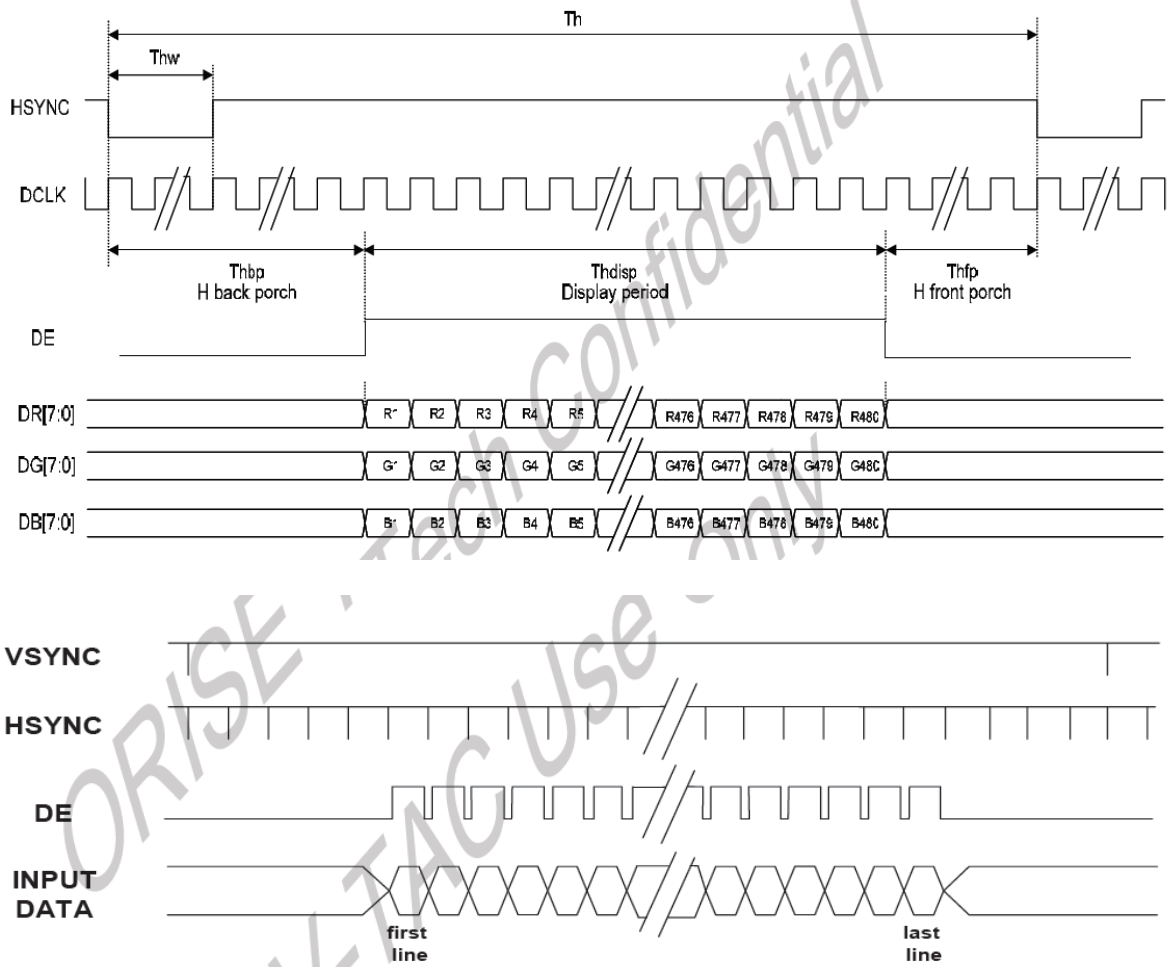

DISTRIBUTED BY TEXIM EUROPE

7-3 AC Timing characteristic of the capacitive touch panel IIC Interface (T/P Controller) Slave Address=0x5C.

Standard IIC Timing

Write Operating

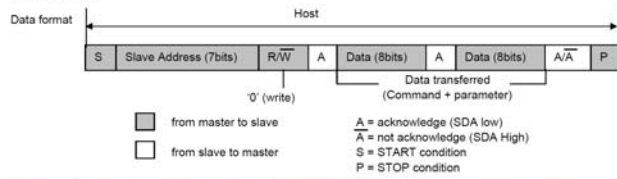

Example 1 (Set Drive Line Number to 18 lines (1 parameter command))

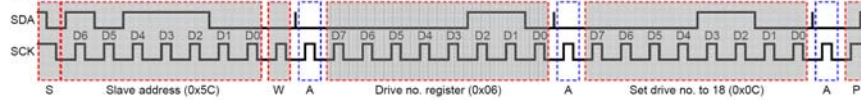

Example 2 (Set Single click time to 100ms (2 parameters command))

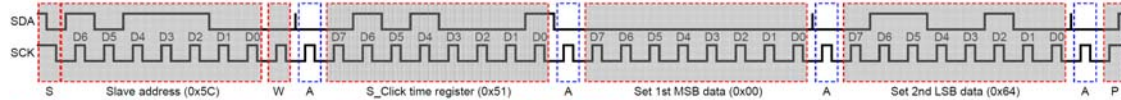

Note: All the command and parameter data byte must be sent within 1 transaction (i.e. between START and STOP signal)

Read Operation

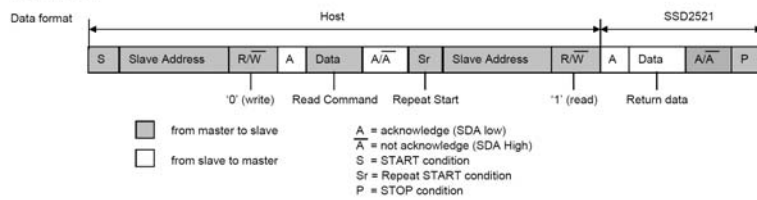

Example (Read ID from SSD2521)

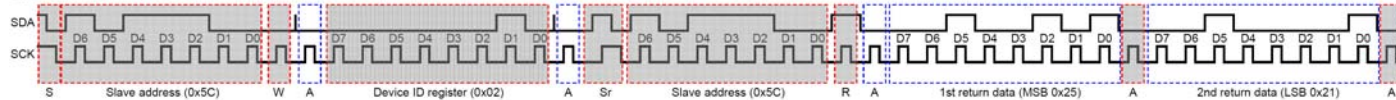

Note: A Repeat-START condition must be use between the address setup and data read transaction.

All the data must be read within one transaction of the address counter will return to 0 after the SSD2521 received a STOP signal (i.e. the return data will always start from 1st data byte when host issued READ request).

Symbol	Parameter	Min	Typ	Max	Unit
t_{cycle}	Clock Cycle Time	2.5	-	-	us
t_{HSTART}	Start condition Hold Time	0.6	-	-	us
t_{HD}	Data Hold Time (for "SDA _{OUT} " pin)	0	-	-	ns
	Data Hold Time (for "SDA _N " pin)	300	-	-	ns
t_{SD}	Data Setup Time	100	-	-	ns
t_{SSTART}	Start condition Setup Time (Only relevant for a repeated Start condition)	0.6	-	-	us
t_{SSTOP}	Stop condition Setup Time	0.6	-	-	us
t_R	Rise Time for data and clock pin	-	-	300	ns
t_F	Fall Time for data and clock pin	-	-	300	ns
t_{IDLE}	Idle Time before a new transmission can start	1.3	-	-	us

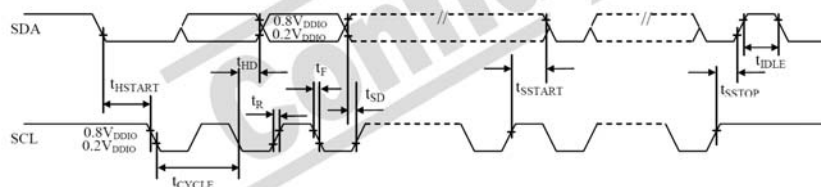

Symbol	Parameter	Min	Typ	Max	Unit
t_{PR}	Power rise time	-	-	30	us
t_{PD}	Power delay time	-	-	30	us
t_{STABLE}	Chip stable time	-	-	10	us
t_{RES}	Reset pulse	4	-	-	us
t_{READY}	Chip need time after hardware reset	-	-	1	us

DISTRIBUTED BY TEXIM EUROPE

7-4 TP controller command table

Reg#	Function	R/W/C	No. of Byte	Parameter	Default
R00h	No Operation	C	0	N/A	N/A
R01h	Software Reset	C	0	N/A	N/A
R02h	Device ID	R	2	nibble based representation of "2521"	0x2521
R06h	Number of Driving Electrodes	W	1	[7:4]: Reserved [3:0]: Select between 6 to 21 electrodes according to mapping in specification.	0x0F
R07h	Number of Sensing Electrodes	W	1	[7:3]: Reserved [2:0]: Select between 6 to 12 electrodes according to mapping in specification.	0x06
R08h	Select Drive Pin and Slew Rate for Drive Line 00	W	1	[7:5] Slew rate [4:0] Drive pin select	0x00
R09h	Select Drive Pin and Slew Rate for Drive Line 01	W	1	[7:5] Slew rate [4:0] Drive pin select	0x01
RAh	Select Drive Pin and Slew Rate for Drive Line 02	W	1	[7:5] Slew rate [4:0] Drive pin select	0x02
RBh	Select Drive Pin and Slew Rate for Drive Line 03	W	1	[7:5] Slew rate [4:0] Drive pin select	0x03
RCh	Select Drive Pin and Slew Rate for Drive Line 04	W	1	[7:5] Slew rate [4:0] Drive pin select	0x04
RDh	Select Drive Pin and Slew Rate for Drive Line 05	W	1	[7:5] Slew rate [4:0] Drive pin select	0x05
REh	Select Drive Pin and Slew Rate for Drive Line 06	W	1	[7:5] Slew rate [4:0] Drive pin select	0x06
RFh	Select Drive Pin and Slew Rate for Drive Line 07	W	1	[7:5] Slew rate [4:0] Drive pin select	0x07
R10h	Select Drive Pin and Slew Rate for Drive Line 08	W	1	[7:5] Slew rate [4:0] Drive pin select	0x08
R11h	Select Drive Pin and Slew Rate for Drive Line 09	W	1	[7:5] Slew rate [4:0] Drive pin select	0x09
R12h	Select Drive Pin and Slew Rate for Drive Line 10	W	1	[7:5] Slew rate [4:0] Drive pin select	0x0A
R13h	Select Drive Pin and Slew Rate for Drive Line 11	W	1	[7:5] Slew rate [4:0] Drive pin select	0x0B
R14h	Select Drive Pin and Slew Rate for Drive Line 12	W	1	[7:5] Slew rate [4:0] Drive pin select	0x0C
R15h	Select Drive Pin and Slew Rate for Drive Line 13	W	1	[7:5] Slew rate [4:0] Drive pin select	0x0D
R16h	Select Drive Pin and Slew Rate for Drive Line 14	W	1	[7:5] Slew rate [4:0] Drive pin select	0x0E
R17h	Select Drive Pin and Slew Rate for Drive Line 15	W	1	[7:5] Slew rate [4:0] Drive pin select	0x0F
R18h	Select Drive Pin and Slew Rate for Drive Line 16	W	1	[7:5] Slew rate [4:0] Drive pin select	0x10
R19h	Select Drive Pin and Slew Rate for Drive Line 17	W	1	[7:5] Slew rate [4:0] Drive pin select	0x11
R1Ah	Select Drive Pin and Slew Rate for Drive Line 18	W	1	[7:5] Slew rate [4:0] Drive pin select	0x12

DISTRIBUTED BY TEXIM EUROPE

R1Bh	Select Drive Pin and Slew Rate for Drive Line 19	W	1	[7:5] Slew rate [4:0] Drive pin select	0x13
R1Ch	Select Drive Pin and Slew Rate for Drive Line 20	W	1	[7:5] Slew rate [4:0] Drive pin select	0x14
R23h	System Enable (wake-up)	C	1	Dummy Byte. For example, 0x00 can be sent.	N/A
R24h	System Disable (go to sleep)	C	1	Dummy Byte. For example, 0x00 can be sent.	N/A
R25h	Write Operation Mode	W	1	[7:4]: reserved [3:0]: 0000 = Idle mode 0001 = Idle mode 0010 = Fast Scan, 200Hz 0011 = Fast Scan, 166Hz 0100 = Fast Scan, 142Hz 0101 = Fast Scan, 125Hz 0110 = Fast Scan, 100Hz 0111 = Normal Scan, 83.3Hz 1000 = Normal Scan, 71.4Hz 1001 = Normal Scan, 62.5Hz 1010 = Normal Scan, 55.5Hz 1011 = Normal Scan, 50.0Hz 1100 = Slow Scan, 45.5Hz 1101 = Slow Scan, 37.0Hz 1110 = Slow Scan, 30.3Hz 1111 = Slow Scan, 25.0Hz	0x00
R26h	Read Operation Mode	R	1	Ditto	0x00
R27h	Set Power Down Time	W	1	[7:3]: reserved [2:0]: 000 = 200ms (5Hz) 001 = 140ms (7Hz) 010 = 100ms (10Hz) 011 = 70ms (14Hz) 100 = 50ms (20Hz) 101 = 35ms (28Hz) 110 = 25ms (40Hz) 111 = 17.7ms (56Hz)	0x04
R28h	Set No. of Frames escape without finger touch before entering Power Save Mode.	W	1	[7:4]: reserved [3:0]: 0000 = 20 frames 0001 = 40 frames 0010 = 60 frames 0011 = 80 frames 0100 = 100 frames 0101 = 120 frames 0110 = 140 frames 0111 = 160 frames 1000 = 180 frames 1010 = 200 frames 1011 = 220 frames 1100 = 240 frames 1101 = 260 frames 1110 = 280 frames 1111 = 300 frames 1111 = 320 frames	0x08
R29h	Number of idle cycles insert between driving two rows.	W	1	[7:4]: reserved [2:0] =: No. of idle cycles – 2 Range: 2 – 9 cycles	0x07

DISTRIBUTED BY TEXIM EUROPE

R2Ah	Number of Sub Frames per frame scan.	W	1	[7:2]: reserved [1:0]: No. of sub frames – 1 Range: 1 – 4 sub frames	0x03
R33h	Min Finger Area (in unit of crossover points)	W	1	[7:0]: set minimum area for valid finger detection	0x02
R34h	Min Finger Level (in unit of delta difference)	W	1	[7:0] set minimum level for valid finger detection	0x05
R35h	Min Finger Weight (in unit of delta difference)	W	2	[7:0]: set minimum weight for valid finger detection	0x00 0x0A
R36h	Max Finger Area (in unit of crossover points)	W	1	[7:0]: set maximum area for valid finger detection	0x1E
R37h	Control depth of image segmentation	W	1	[7:2]: reserved [1:0]: 0 = 68% of max value 1 = 63% of max value 2 = 56% of max value 3 = 49% of max value	0x00
R38h	Select Delta Data Range	W	1	[7:2]: reserved [1:0]: 00 = delta_data[7:0] 01 = delta_data[8:1] 10 = delta_data[9:2] 11 = delta_data[10:3]	0x00
R39h	Select CG calculation method	W	1	[7:1]: reserved [0]: 0 = Weighted Avg. 1 = Curve Fitting	0x00
R3Ah	Enable filtering in init calibration sequence	W	1	[7:1]: reserved [0]: 0 = disable filter 1 = enable filter	0x00
R3Bh	Invert polarity of delta	W	1	[7:1]: reserved [0]: 0 = invert 1 = non-invert	0x00
R51h	Single Click Timing (in 1ms unit)	W	2	[15:11]: Reserved [10:0]: define single click timing	0x00 0x00
R52h	Double Click Timing (in 1ms unit)	W	2	[15:11]: Reserved [10:0]: define double click timing	0x00 0x00
R53h	CG Tolerance (in 1/32 electrode span)	W	1	[7]: Reserved [6:0]: define CG tolerance	0x00
R54h	X Tracking tolerance (in 1/32 electrode span)	W	1	[7:0]: X coordinate tracking tolerance	0x00
R55h	Y Tracking tolerance (in 1/32 electrode span)	W	1	[7:0] Y coordinate tracking tolerance	0x00
R56h	Enable Adaptive Moving Average filter to smooth fingers' output coordinates.	W	1	[7:1]: reserved [0]: 0 = disable filter 1 = enable filter	0x00
R57h	Select the scaling factor for finger speed (in 1/32 electrode span)	W	1	[7:1]: reserved [0]: 0 = speed / 4 1 = speed / 8	0x00
R58h	Select the scaling factor for finger press weight (in unit of a delta difference)	W	1	[7:2]: reserved [1:0]: 00 = weight/1 01 = weight/2 10 = weight/4 11 = weight/8	0x00

DISTRIBUTED BY TEXIM EUROPE

R66h	Scaling factor for X coordinate. Floating point format is ##.#####.	W	1	[7:0]: X scaling factor. 2-bit integer part and 6-bit fractional part.	0x40
R67h	Scaling factor for Y coordinate. Floating point format is ##.#####.	W	1	[7:0]: Y scaling factor. 2-bit integer part and 6-bit fractional part.	0x40
R68h	Offset of X coordinate. (in unit of pixel. That is, after X scaling)	W	1	[7:6]: reserved [5:0]: X offset	0x00
R69h	Offset of Y coordinate. (in unit of pixel. That is, after Y scaling)	W	1	[7:6]: reserved [5:0]: Y offset	0x00
R79h	Event Status	R	1	[7]: Reserved [6]: Large Object detected [5]: FIFO overflow [4]: FIFO not empty [3]: Finger 3 detected [2]: Finger 2 detected [1]: Finger 1 detected [0]: Finger 0 detected	N/A
R7Ah	Event Mask	W	2	[15]: Unknown event mask [14:8]: Reserved [7]: FM Event mask [6]: FL Event mask [5]: FE Event mask [4]: DFDC Event mask [3]: DFSC Event mask [2]: SFDC Event mask [1]: SFSC Event mask [0]: Reserved	0x00 0x00
R7Bh	IRQ Mask	W	1	[7]: Reserved [6]: Large Object status mask [5]: FIFO overflow status mask [4]: FIFO not empty status mask [3]: Finger03 status mask [2]: Finger02 status mask [1]: Finger01 status mask [0]: Finger00 status mask	0x00
R7Ch	Finger01 (X,Y) coordinates, speed index and press weight index.	R	4	[31:24]: x-coordinate[7:0] [23:16]: y-coordinate[7:0] [15:12]: x-coordinate [11:8] [11:08]: y-coordinate [11:8] [07:04]: press weight index[3:0] [03:00]: speed index [3:0]	0xFF 0xFF 0xFF 0x00
R7Dh	Finger02 (X,Y) coordinates, speed index and press weight index.	R	4	Ditto	Ditto
R7Eh	Finger03 (X,Y) coordinates, speed index and press weight index.	R	4	Ditto	Ditto
R7Fh	Finger04 (X,Y) coordinates, speed index and press weight index.	R	4	Ditto	Ditto

DISTRIBUTED BY TEXIM EUROPE

R80h	Event Stack	R	4	[31:28]: Finger flag [3:0] [27:24]: Event number [3:0] [23:16]: x-coordinate[7:0] [15:08]: y-coordinate[7:0] [07:04]: x-coordinate [11:8] [03:00]: y-coordinate [11:8]	0x00 0xFF 0xFF 0xFF
R81h	Event Stack Clear	C	0	Clear the Event Stack when not overflow	N/A
RA2h	Reset Init Reference Procedure	W	1	Dummy Byte	N/A
RC1h	Charge Pump 2 nd Booster Control	W	1	[7:6]: Reserved [5:4]: 2 nd Booster Control 00: x6 01: Reserved 10: x5 11: x4 [3:0]: Reserved	0x32
RD5h	Select Driving voltage level	W	1	[7:4]: reserved [3:0]: 0 = 8.0V, 1 = 8.5V 2 = 9.0V, 3 = 9.5V 4 = 10.0V, 5 = 10.5V 6 = 11.0V, 7 = 11.5V 8 = 12.0V, 9 = 12.5V 10 = 13.0V, 11 = 13.5V 12 = 14.0V, 13 = 14.5V 14 = 15.0V, 15 = 15.5V	0x00

*Check the datasheet of SSD2531 for further detail.

7-5 Initial Code

```
void SSD2531_ini (void)
```

```
{  
IO_I2C_WR(0x5C,0x23,0x00); //System Enable (R23h)  
IO_I2C_WR(0x5C,0x2B,0x03); //Drive Line Number Register (R06h) =19  
IO_I2C_WR(0x5C,0xD4,0x01); //Sense Line Number Register (R07h) =11  
IO_I2C_WR(0x5C,0x06,0x0D); //Drive Line Number Register (R06h) =19  
IO_I2C_WR(0x5C,0x07,0x06); //Sense Line Number Register (R07h) =11  
IO_I2C_WR(0x5C,0x08,0x00); //Drive Line 00 DRIVER01  
IO_I2C_WR(0x5C,0x09,0x01); //Drive Line 01 DRIVER02  
IO_I2C_WR(0x5C,0x0A,0x02); //Drive Line 02 DRIVER03  
IO_I2C_WR(0x5C,0x0B,0x03); //Drive Line 03 DRIVER04  
IO_I2C_WR(0x5C,0x0C,0x04); //Drive Line 04 DRIVER05  
IO_I2C_WR(0x5C,0x0D,0x05); //Drive Line 05 DRIVER06  
IO_I2C_WR(0x5C,0x0E,0x06); //Drive Line 06 DRIVER07  
IO_I2C_WR(0x5C,0x0F,0x07); //Drive Line 07 DRIVER08  
IO_I2C_WR(0x5C,0x10,0x08); //Drive Line 08 DRIVER09  
IO_I2C_WR(0x5C,0x11,0x09); //Drive Line 09 DRIVER10  
IO_I2C_WR(0x5C,0x12,0x0A); //Drive Line 10 DRIVER11  
IO_I2C_WR(0x5C,0x13,0x0B); //Drive Line 11 DRIVER12  
IO_I2C_WR(0x5C,0x14,0x0C); //Drive Line 12 DRIVER13  
IO_I2C_WR(0x5C,0x15,0x0D); //Drive Line 13 DRIVER14  
IO_I2C_WR(0x5C,0x16,0x0E); //Drive Line 14 DRIVER15  
IO_I2C_WR(0x5C,0x17,0x0F); //Drive Line 15 DRIVER16  
IO_I2C_WR(0x5C,0x18,0x10); //Drive Line 16 DRIVER17  
IO_I2C_WR(0x5C,0x19,0x11); //Drive Line 17 DRIVER18  
IO_I2C_WR(0x5C,0x1A,0x12); //Drive Line 18 DRIVER19  
IO_I2C_WR(0x5C,0x2A,0x04); //Number of Sub Frames per frame scan.  
IO_I2C_WR(0x5C,0x8D,0x01); //Change system to manual scan mode  
IO_I2C_WR(0x5C,0x8E,0x02); //  
IO_I2C_WR_2Byte(0x5C,0x94,0x00,0x00); //  
IO_I2C_WR(0x5C,0x8D,0x00); //Change system to manual scan mode  
IO_I2C_WR(0x5C,0x25,0x09); //Write Operation Mode  
IO_I2C_WR(0x5C,0xC1,0x02); ///Charge Pump 2nd Booster Control  
IO_I2C_WR(0x5C,0xD5,0x0A); //Select Driving voltage level  
IO_I2C_WR(0x5C,0x38,0x00); //Select Delta Data Range  
IO_I2C_WR(0x5C,0x33,0x00); //Min Finger Area Setting Register  
IO_I2C_WR(0x5C,0x34,0x40); //Min Finger Level Setting Register  
IO_I2C_WR_2Byte(0x5C,0x35,0x00,0x40); //Min Finger Weight Setting Register  
IO_I2C_WR(0x5C,0x36,0x1E); //Max Finger Area Setting Register  
IO_I2C_WR(0x5C,0x37,0x02); //Control depth of image segmentation  
IO_I2C_WR(0x5C,0x39,0x01); //Select CG calculation method  
IO_I2C_WR(0x5C,0x56,0x01); //Enable Adaptive Moving Average filter to  
smooth fingers' output coordinates.  
IO_I2C_WR_2Byte(0x5C,0x51,0x00,0xFF); //Single Click Timeing  
IO_I2C_WR_2Byte(0x5C,0x52,0x00,0xFF); //Double Click Timer Setting Register  
IO_I2C_WR(0x5C,0x53,0x35); //CG Tolerance Setting Register  
IO_I2C_WR(0x5C,0x54,0x40); //X Tracking Tolerance Register  
IO_I2C_WR(0x5C,0x55,0x40); //Y Tracking Tolerance Register  
IO_I2C_WR(0x5C,0xD9,0x01); //scaling factor
```

```

IO_I2C_WR(0x5C,0xD8,0x02); //scaling factor
IO_I2C_WR(0x5C,0xD7,0x06); //scaling factor
IO_I2C_WR(0x5C,0x2C,0x01); //scaling factor
IO_I2C_WR(0x5C,0xAE,0x0F); //scaling factor
IO_I2C_WR(0x5C,0xBC,0x01); //scaling factor
IO_I2C_WR(0x5C,0x3D,0x01); //?
IO_I2C_WR(0x5C,0x66,0x36); //scaling factor //scaling factor
(11-1)*32=320=====>320/resolution x =0.85
IO_I2C_WR(0x5C,0x67,0x35); //scaling factor //scaling factor
(19-1)*32=576=====>576/resolution Y =0.83
IO_I2C_WR(0x5C,0xD6,0x01); //scaling factor
IO_I2C_WR(0x5C,0xA2,0x00); //Reset Init Reference Procedure
}

```

7-6 Sample code

```

void coord_reporter(void)
{
    u32 PCT_Z[12],PCT_Y[12],PCT_X[12];
    u16 a;
    Full_LCD(0x0000);
    SET_TPCS; //Reset IC
    Delay(5);
    CLR_TPCS;
    Delay(5);
    SET_TPCS; //Reset IC
    SSD2521_ini();
    Delay(5);
    PCT_Z[0]=0x0000;
    PCT_Z[1]=0x0000;
    PCT_Z[2]=0x0000;
    PCT_Z[3]=0x0000;
    PCT_Z[4]=0x0000;
    PCT_Z[5]=0x0000;
    PCT_X[0]=0x0000;
    PCT_X[1]=0x0000;
    PCT_X[2]=0x0000;
    PCT_X[3]=0x0000;
    PCT_X[4]=0x0000;
    PCT_X[5]=0x0000;
    PCT_Y[0]=0x0000;
    PCT_Y[1]=0x0000;
    PCT_Y[2]=0x0000;
    PCT_Y[3]=0x0000;
    PCT_Y[4]=0x0000;
    PCT_Y[5]=0x0000;
}

```

```

while(1)
{
  if((ReadINT()==0)
  {
    IO_I2C_RD(0x5C,0x79,1);
    PCT_Z[0]=(u16)((u16)pbuffer[0]);//finger No.
    IO_I2C_RD(0x5C,0x80,4)
      if((PCT_Z[0]&0x0003)==0x0001)
        {
          IO_I2C_RD(0x5C,0x7C,4);
          PCT_X[0]=(u16)((u16)pbuffer[0]+((pbuffer[2]&0x0300)<<4));
          PCT_Y[0]=(u16)((u16)pbuffer[1]+((pbuffer[2]&0x0003)<<8));
          IO_I2C_RD(0x5C,0x80,4);
          IO_I2C_RD(0x5C,0x7D,4);
          PCT_X[1]=(u16)((u16)pbuffer[0]+((pbuffer[2]&0x0300)<<4));
          PCT_Y[1]=(u16)((u16)pbuffer[1]+((pbuffer[2]&0x0003)<<8));
          IO_I2C_RD(0x5C,0x80,4);
          PCT_X[4]=PCT_X[0];      //coordinate X1
          PCT_Y[4]=PCT_Y[0];      //coordinate Y1
          PCT_X[5]=PCT_X[1];      //coordinate X2
          PCT_Y[5]=PCT_Y[1];      //coordinate Y2
        }
      }
    }
}

```

7-7 Color Data Assignment

COLOR	Input Data	R DATA						G DATA						B DATA					
		R5 MSB	R4	R3	R2	R1	R0 LSB	G5 MSB	G4	G3	G2	G1	G0 LSB	B5 MSB	B4	B3	B2	B1	B0 LSB
BASIC COLOR	BLACK	0	0	0	0	0	0	0	0	0	0	0	0	0	0	0	0	0	0
	RED(63)	1	1	1	1	1	1	0	0	0	0	0	0	0	0	0	0	0	0
	GREEN(63)	0	0	0	0	0	0	1	1	1	1	1	1	0	0	0	0	0	0
	BLUE(63)	0	0	0	0	0	0	0	0	0	0	0	0	1	1	1	1	1	1
	CYAN	0	0	0	0	0	0	1	1	1	1	1	1	1	1	1	1	1	1
	MAGENTA	1	1	1	1	1	1	0	0	0	0	0	0	1	1	1	1	1	1
	YELLOW	1	1	1	1	1	1	1	1	1	1	1	1	0	0	0	0	0	0
	WHITE	1	1	1	1	1	1	1	1	1	1	1	1	1	1	1	1	1	1
RED	RED(0)	0	0	0	0	0	0	0	0	0	0	0	0	0	0	0	0	0	0
	RED(1)	0	0	0	0	0	1	0	0	0	0	0	0	0	0	0	0	0	0
	RED(2)	0	0	0	0	1	0	0	0	0	0	0	0	0	0	0	0	0	0
	RED(62)	1	1	1	1	1	0	0	0	0	0	0	0	0	0	0	0	0	0
	RED(63)	1	1	1	1	1	1	0	0	0	0	0	0	0	0	0	0	0	0
GREEN	GREEN (0)	0	0	0	0	0	0	0	0	0	0	0	0	0	0	0	0	0	0
	GREEN (1)	0	0	0	0	0	0	0	0	0	0	0	1	0	0	0	0	0	0
	GREEN (2)	0	0	0	0	0	0	0	0	0	0	1	0	0	0	0	0	0	0
	GREEN (62)	0	0	0	0	0	0	1	1	1	1	1	0	0	0	0	0	0	0
	GREEN (63)	0	0	0	0	0	0	1	1	1	1	1	1	0	0	0	0	0	0
BLUE	BLUE (0)	0	0	0	0	0	0	0	0	0	0	0	0	0	0	0	0	0	0
	BLUE (1)	0	0	0	0	0	0	0	0	0	0	0	0	0	0	0	0	0	1
	BLUE (2)	0	0	0	0	0	0	0	0	0	0	0	0	0	0	0	0	1	0
	BLUE (62)	0	0	0	0	0	0	0	0	0	0	0	0	0	0	0	0	0	1
	BLUE (63)	0	0	0	0	0	0	0	0	0	0	0	0	0	0	0	0	1	0

- NOTE : (1) Definition of Gray Scale , Color(n) : n is series of Gray Scale
The more n value is the bright Gray Scale
(2) Data : 1-High , 0-Low

8. OPTICAL CHARACTERISTICS

Item	Symbol	Condition	Min.	Typ.	Max.	Unit	Note	
Contrast ratio	CR	Point - 5 $\Theta = \Phi = 0^\circ$	--	500	--	--	(1)(2)(3)	
Luminance	Lw		--	450	-	cd/m ²	(1)(3)	
Luminance Uniformity	ΔL		70	75	-	%	(1)(3)	
Response Time (White – Black)	$T_r + T_f$		--	35	--	ms	(1)(3)(5)	
Viewing Angle	Horizontal	Θ_h	CR > 10	--	160	-	Deg.	(1)(2)(4)
	Vertical	Θ_v		--	160	-		
Color chromaticity	Red	Rx	Point - 5 $\Theta = \Phi = 0^\circ$	0.633	0.653	0.673	--	(1)(3)
		Ry		0.312	0.332	0.352		
	Green	Gx		0.294	0.314	0.334		
		Gy		0.554	0.575	0.595		
	Blue	Bx		0.117	0.137	0.157		
		By		0.113	0.133	0.153		
	White	Wx		0.287	0.307	0.327		
		Wy		0.321	0.341	0.361		

NOTE :

- (1) Measure conditions : $25^\circ\text{C} \pm 2^\circ\text{C}$, $60 \pm 10\% \text{RH}$ under 10Lux , in the dark room by BM-7TOPCON) , viewing 2° , VCC=3.3V , VDD=3.3V

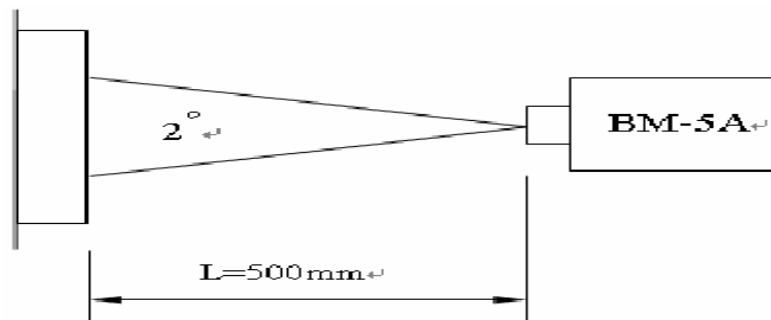

- (2) Definition of Contrast Ratio :

Contrast Ratio (CR) = (White) Luminance of ON ÷ (Black) Luminance of OFF

- (3) Definition of Luminance :

Definition of Luminance Uniformity

Measure white luminance on the point 5 as figure9-1

Measure white luminance on the point 1 ~ 9 as figure9-1

$$\Delta L = [L(\text{MIN}) / L(\text{MAX})] \times 100\%$$

DISTRIBUTED BY TEXIM EUROPE

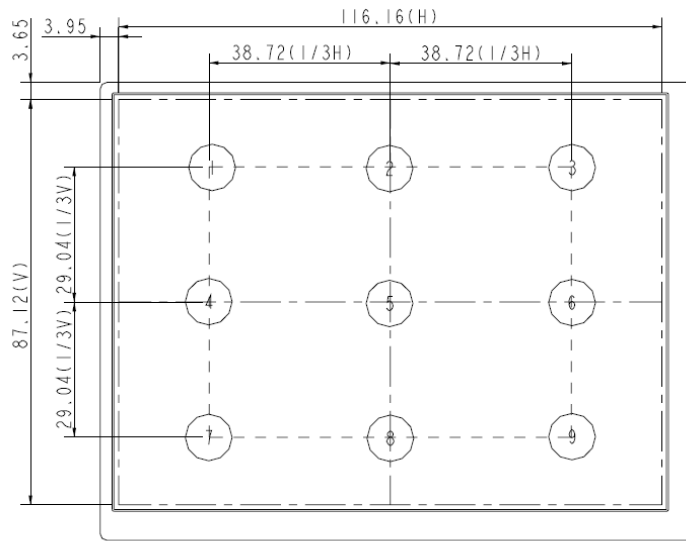

Fig9-1 Measuring point

(4) Definition of Viewing Angle(Θ, Φ), refer to Fig9-2 as below :

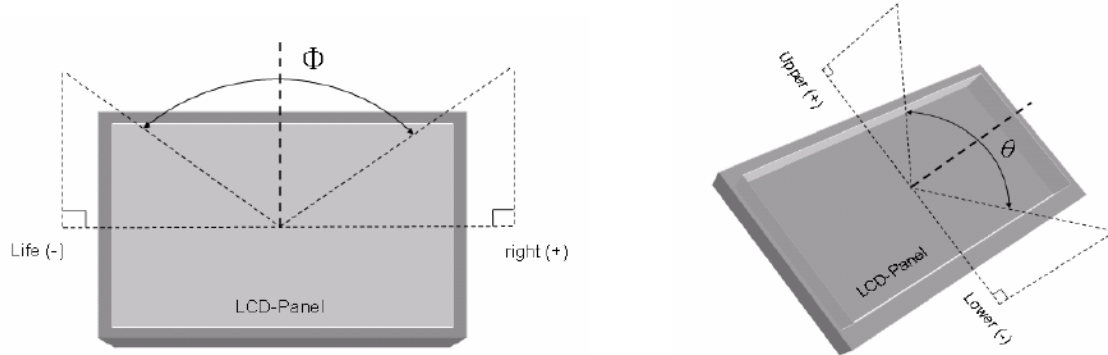

Fig9-2 Definition of Viewing Angle

(5) Definition of Response Time.(White – Black)

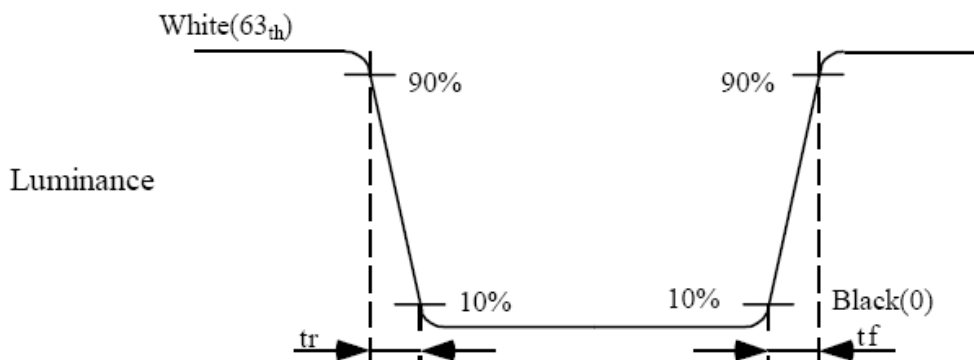

Fig9-3 Definition of Response Time(White-Black)

9 INCOMING INSPECTION STANDARD FOR TFT-LCD PANEL

DEFECT TYPE		LIMIT				Note		
VISUAL DEFECT	INTERNAL	SPOT	$\phi < 0.15\text{mm}$		Ignore	Note1		
			$0.15\text{mm} \leq \phi \leq 0.5\text{mm}$		$N \leq 4$			
			$0.5\text{mm} < \phi$		$N=0$			
		FIBER	$0.03\text{mm} < W \leq 0.1\text{mm},$ $L \leq 5\text{mm}$		$N \leq 3$		Note1	
			$1.0\text{mm} < W, 1.5\text{mm} < L$		$N=0$			
		POLARIZER BUBBLE	$\phi < 0.15\text{mm}$		Ignore		Note1	
			$0.15\text{mm} \leq \phi \leq 0.5\text{mm}$		$N \leq 2$			
			$0.5\text{mm} < \phi$		$N=0$			
		Mura	It' OK if mura is slight visible through 6%ND filter					
ELECTRICAL DEFECT	BRIGHT DOT	A Grade			B Grade			
		C Area	O Area	Total	C Area	O Area	Total	Note3
		$N \leq 0$	$N \leq 2$	$N \leq 2$	$N \leq 2$	$N \leq 3$	$N \leq 5$	Note2
	DARK DOT	$N \leq 2$	$N \leq 3$	$N \leq 3$	$N \leq 3$	$N \leq 5$	$N \leq 8$	
	TOTAL DOT	$N \leq 4$			$N \leq 5$	$N \leq 6$	$N \leq 8$	Note2
	TWO ADJACENT DOT	$N \leq 0$	$N \leq 1$ pair	$N \leq 1$ pair	$N \leq 1$ pair	$N \leq 1$ pair	$N \leq 1$ pair	Note4
	THREE OR MORE ADJACENT DOT	NOT ALLOWED						
	LINE DEFECT	NOT ALLOWED						

(1) One pixel consists of 3 sub-pixels, including R,G, and B dot.(Sub-pixel = Dot)

(2) LITTLE BRIGHT DOT ACCEPTABLE UNDER 6 % ND-Filter

[Note1] W : Width[mm], L : Length[mm], N : Number, ϕ : Average Diameter

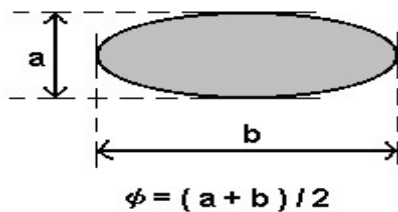

1. (White, black) Spot
2. Polarizer Bubble

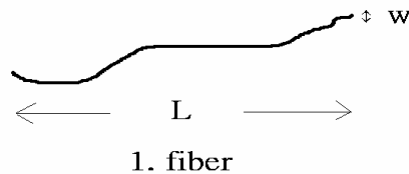

DISTRIBUTED BY TEXIM EUROPE

[Note2] Bright dot is defined through 6% transmission ND Filter as following.

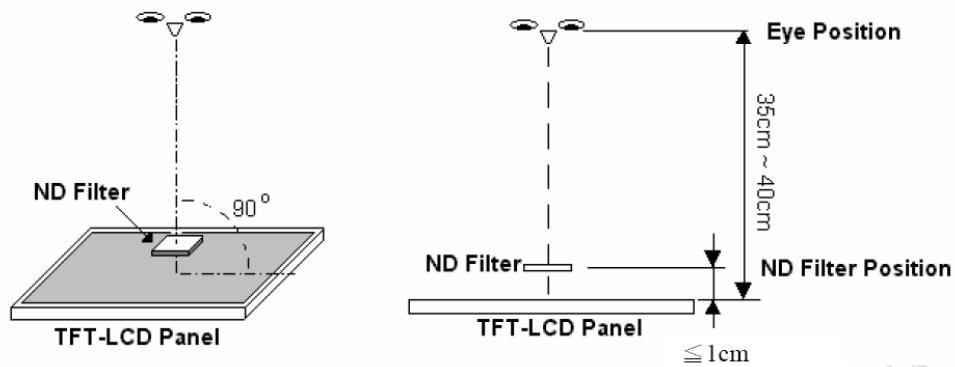

[Note3]

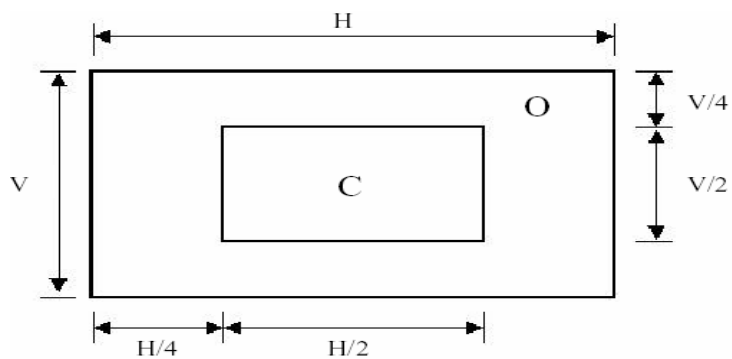

C Area: Center of display area

C Area: Outer of display area

[Note4]

Judge defect dot and adjacent dot as following. Allow below (as A, B, C and D status) adjacent defect dots, including bright and dart adjacent dot. And they will be counted 2 defect dots in total quantity.

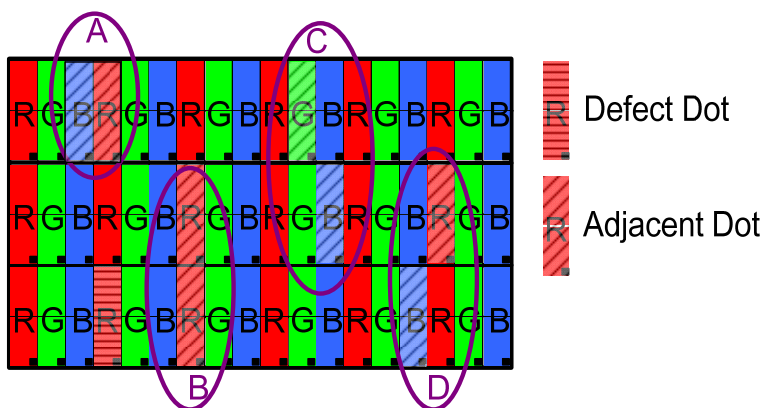

- (1) The defects that are not defined above and considered to be problem shall be reviewed and discussed by both parties.
- (2) Defects on the Black Matrix, out of Display area, are not considered as a defect or counted.

DISTRIBUTED BY TEXIM EUROPE

10. RELIABILITY TEST CONDITIONS

ITEM	CONDITIONS
HIGH TEMPERATURE OPERATION	70°C , 240Hrs
HIGH TEMPERATURE AND HIGH HUMIDITY OPERATION	60°C , 90%RH , 240Hrs
HIGH TEMPERATURE STORAGE	80°C , 240Hrs
LOW TEMPERATURE OPERATION	-20°C , 240Hrs
LOW TEMPERATURE STORAGE	30°C , 240Hrs
THERMAL SHOCK	-20°C (0.5Hr) ~70°C (0.5Hr) 200Cycle

10.1 OTHERS

AMIPRE will provide one year warranty for all products and three months warrantee for all repairing products.

11. OUTLINE DIMENSION

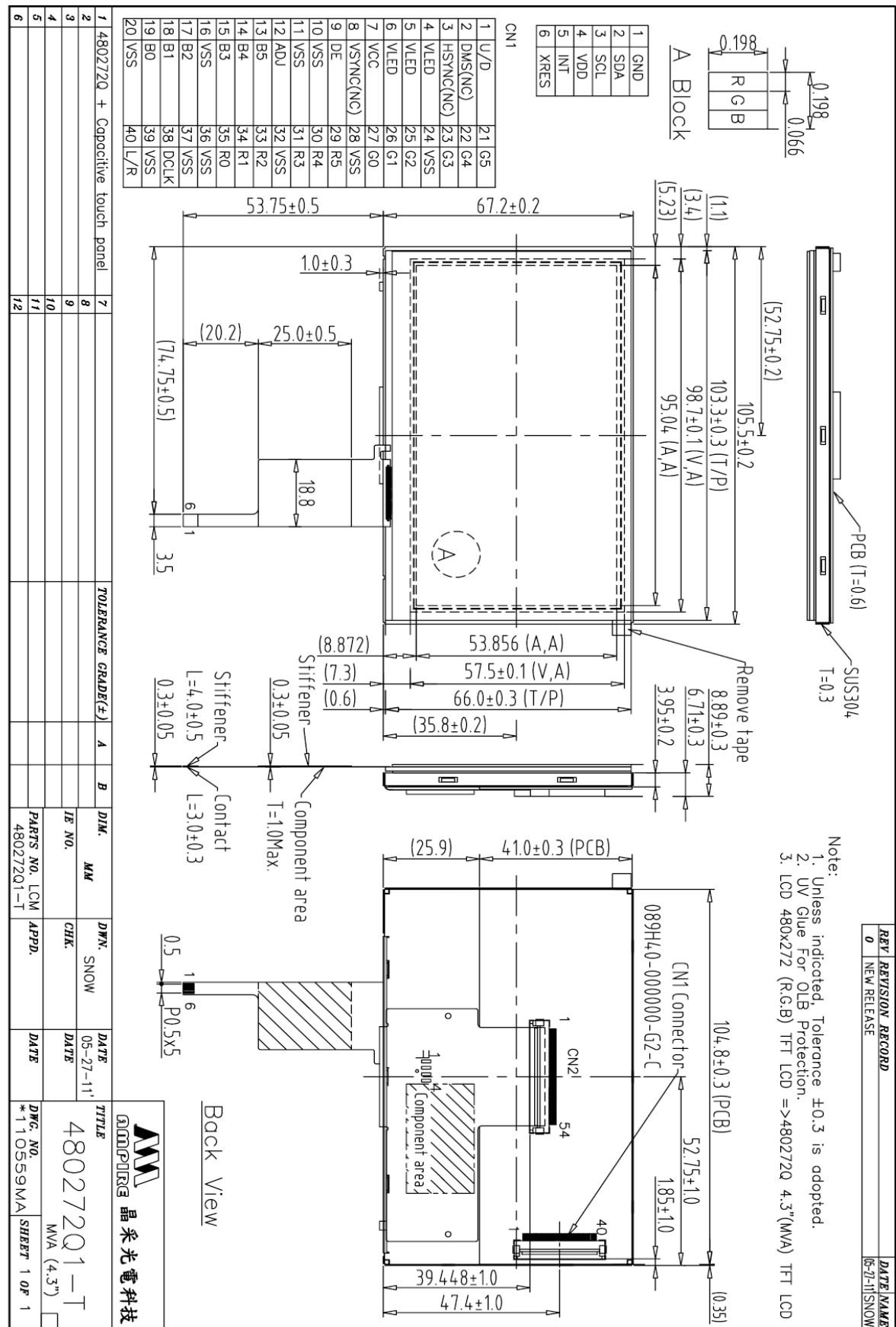

DISTRIBUTED BY TEXIM EUROPE

TEXIM EUROPE

Partner in Electronic Components & Supply Chain Solutions



The Netherlands

Elektrostraat 17
NL-7483 PG Haaksbergen
Tel: +31 (0)53 573 33 33
Fax: +31 (0)53 573 33 30
nl@texim-europe.com



Denmark

Nørregade 15
DK-9240 Nibe
Tel: +45 88 20 26 30
Fax: +45 88 20 26 39
nordic@texim-europe.com



Belgium

Gentsesteenweg 1154-C22
Chaussée de Gand 1154-C22
B-1082 Brussel / Bruxelles
Tel: +32 (0)2 462 01 00
Fax: +32 (0)2 462 01 99
belgium@texim-europe.com



United Kingdom

St. Mary's House, Church Lane
Carlton Le Moorland
Lincoln LN5 9HS
Tel: +44 (0)1522 789 555
Fax: +44 (0)845 299 22 26
uk@texim-europe.com



Germany

Justus-von-Liebig-Ring 7-9
D-25451 Quickborn
Tel: +49 (0)4106 627 07-0
Fax: +49 (0)4106 627 07-20
germany@texim-europe.com



Germany

Martin-Kollar-Strasse 9
D-81829 München
Tel: +49 (0)89 436 086-0
Fax: +49 (0)89 436 086-19
germany@texim-europe.com



Austria

Warwitzstrasse 9
A-5020 Salzburg
Tel: +43 (0)662 216026
Fax: +43 (0)662 216026-66
austria@texim-europe.com

Texim Europe B.V.

Elektrostraat 17
NL-7483 PG Haaksbergen
Tel: +31 (0)53 573 33 33
info@texim-europe.com
www.texim-europe.com

