



File Name	Specification For HINK 2.13" EPD	Module Number	HINK-E0213A01
Version	A/0	Page Number	1 of 28

Specification for HINK 2.13"EPD

Model NO.:HINK-E0213A01

Customer approval

Customer	
Approval by	
Date of approval	

Prepared by	Checked by	Approval by
Zhai chongzhi	Jia pengfei	Ma zewu





THINGWELL ELECTRONICS

TEL:+86-755-27435731 FAX:+86-755-27132381

<http://www.lcdmaker.com>

File Name	Specification For HINK 2.13" EPD	Module Number	HINK-E0213A01
Version	A/0	Page Number	2 of 28

Version	Content	Date	Producer
A/0	New release	2015/08/27	



File Name	Specification For HINK 2.13" EPD	Module Number	HINK-E0213A01
Version	A/0	Page Number	3 of 28

CONTENTS

1 General Description	4
2 Features	4
3 Application	4
4 Mechanical Specification	4
5 Mechanical Drawing of EPD Module	5
6 Input/Output Terminals	6
7 MCU Interface	7
7.1 MCU interface selection	7
7.2 MCU Serial Peripheral Interface (4-wire SPI)	7
7.3 MCU Serial Peripheral Interface (3-wire SPI)	9
8 Temperature Register Mapping	10
9 Panel Break Detection	10
10 COMMAND TABLE	11
11 Absolute Maximum Rating	15
12 DC Characteristics	16
13 Serial Peripheral Interface Timing	17
13.1 Oscillator Frequency	17
13.2 Interface Timing	17
13.3 Power Consumption	18
14 Reference Circuit	18
15 Typical Operating Sequence	20
16 Optical Characteristics	21
16.1 Specifications	21
16.2 Definition Of Contrast Ratio	21
16.3 Reflection Ratio	22
16.4 Bi-stability	22
17 Handling Safety And Environment Requirements	23
18 Reliability Test	24
19 Block Diagram	25
20 Point And Line Standard	26
21 Packing	28

File Name	Specification For HINK 2.13" EPD	Module Number	HINK-E0213A01
Version	A/0	Page Number	4 of 28

1. General Description

HINK-E0213A01 is an Active Matrix Electrophoretic Display(AMEPD) , with interface and a reference system design. The 2.13" active area contains 122×250 pixels, and has 1-bit full display capabilities. An integrated circuit contains gate buffer, source buffer, interface, timing control logic, oscillator, DC-DC. SRAM. LUT ,VCOM, and border are supplied with each panel.

2. Features

- 122×250 pixels display
- White reflectance above 43%
- Contrast ratio above 10:1
- Ultra wide viewing angle
- Ultra low power consumption
- Pure reflective mode
- Bi-stable display
- Commercial temperature range
- Landscape, portrait modes
- Hard-coat antiglare display surface
- Ultra Low current deep sleep mode
- On chip display RAM
- Waveform stored in On-chip OTP
- Serial peripheral interface available
- On-chip oscillator
- On-chip booster and regulator control for generating VCOM, Gate and Source driving voltage
- I²C signal master interface to read external temperature sensor

3. Application

Electronic Shelf Label System

4. Mechanical Specifications

Parameter	Specifications	Unit	Remark
Screen Size	2.13	Inch	
Display Resolution	122(H)×250(V)	Pixel	
Active Area	23.71(H)×48.55(V)	mm	
Pixel Pitch	0.194×0.194	mm	
Pixel Configuration	Rectangle		
Outline Dimension	29.2(H)×59.2 (V) ×1.05(D)	mm	
Weight	TBD	g	

File Name	Specification For HINK 2.13" EPD	Module Number	HINK-E0213A01
Version	A/0	Page Number	5 of 28

5. Mechanical Drawing of EPD module

已确认此版本的所有图纸
签名: _____ 日期: _____

REV: A2 DESCRIPTION: 分辨率: 250*122 开孔点(C): SSD1673
DATE: 2014.12.10 NAME: X.Z.P

FRONT VIEW

SIDE VIEW

BOTTOM VIEW

易撕贴

NOTES:
1. DISPLAY MODE 2.13" ARREY FOR EPD;
2. DRIVE IC: SSD1673;
3. RESOLUTION: 250gate X 122source;
4. pixel size: 0.1942mm X 0.1943mm;
5. Unspecified Tolerance: ±0.20;
6. Material conform to the ROHS standard

THINGWELL ELECTRONICS COMPANAY LIMITED

ALL UNITS: mm	DATE	MODEL NUMBER:	SH: P1: 1
DWRN: X.Z.P	2014.12.23	HINK-E0213A01-A3	DATE: 2014.12.23
CHK: Shi hao	2014.12.23	CUSTOMER NO:	
APP: jiang xiao hui	2014.12.23	DO NOT SCALE THIS DRAWING!	

PIN	SIGNAL
1	NC
2	GDR
3	REFSE
4	VGL
5	VGH
6	NC
7	NC
8	BS1
9	BUSY
10	RES#
11	D/C#
12	OS#
13	DO
14	DT
15	VDDIO
16	VCL
17	VSS
18	VDD
19	VBP
20	VSH
21	PREVGH
22	VSL
23	PREVGL
24	VCOM

A(2:1)

File Name	Specification For HINK 2.13" EPD	Module Number	HINK-E0213A01
Version	A/0	Page Number	6 of 28

6. Input/Output Terminals

Pin #	Type	Single	Description	Remark
1		NC	No connection and do not connect with other NC pins	Keep Open
2	O	GDR	N-Channel MOSFET Gate Drive Control	
3	O	RESE	Current Sense Input for the Control Loop	
4	C	VGL	Negative Gate driving voltage	
5	C	VGH	Positive Gate driving voltage	
6	-	NC	No connection and do not connect with other NC pins	
7	O	TOUT1	Serial data pin for panel break detection	
8	I	BS1	Bus selection pin	Note 6-5
9	O	BUSY	Busy state output pin	Note 6-4
10	I	RES #	Reset	Note 6-3
11	I	D/C #	Data /Command control pin	Note 6-2
12	I	CS #	Chip Select input pin	Note 6-1
13	I/O	D0 (SCLK)	serial clock pin (SPI)	
14	I/O	D1 (SDIN)	serial data pin (SPI)	
15	I	VDDIO	Power for interface logic pins	
16	I	VCI	Power Supply pin for the chip	
17		VSS	Ground	
18	C	VDD	Core logic power pin	
19	C	VPP	Power Supply for OTP Programming	
20	C	VSH	Positive Source driving voltage	
21	C	PREVGH	Positive Gate driving voltage	
22	C	VSL	Negative Source driving voltage	
23	C	PREVGL	Power Supply pin for VCOM, VGL and VSL	
24	C	VCOM	VCOM driving voltage	

Note 6-1: This pin (CS#) is the chip select input connecting to the MCU. The chip is enabled for MCU communication: only when CS# is pulled LOW.

Note 6-2: This pin (D/C#) is Data/Command control pin connecting to the MCU. When the pin is pulled HIGH, the data will be interpreted as data. When the pin is pulled LOW, the data will be interpreted as command.

Note 6-3: This pin (RES#) is reset signal input. The Reset is active low.

File Name	Specification For HINK 2.13" EPD	Module Number	HINK-E0213A01
Version	A/0	Page Number	7 of 28

Note 6-4: This pin (BUSY) is Busy state output pin. When Busy is Low the operation of chip should not be interrupted and any commands should not be issued to the module. The driver IC will put Busy pin Low when the driver IC is working such as:

- Outputting display waveform; or
- Communicating with digital temperature sensor

Note 6-5: This pin (BS1) is for 3-line SPI or 4-line SPI selection. When it is “Low”, 4-line SPI is selected. When it is “High”, 3-line SPI (9 bits SPI) is selected.

7. MCU Interface

7.1 MCU interface selection

The SSD1673A can support 3-wire/4-wire serial peripheral interface. In the SSD1673A, the MCU interface is pin selectable by BS1 pins shown in.

Table 7-1: MCU interface selection

BS1	MPU Interface
L	4-lines serial peripheral interface (SPI)
H	3-lines serial peripheral interface (SPI) - 9 bits SPI

7.2 MCU Serial Peripheral Interface (4-wire SPI)

The 4-wire SPI consists of serial clock SCLK, serial data SDIN, D/C# and CS#. In SPI mode, D0 acts as SCLK and D1 acts as SDIN. The control pins status in 4-wire SPI in writing command/data is shown in Table 7-1 and the write procedure 4-wire SPI is shown in 错误! 未找到引用源。

Table 7-1 : Control pins status of 4-wire SPI

Function	D0 (SCLK) pin	D1 (SDIN) pin	D/C# pin	CS# pin
Write command	↑	Command bit	L	L
Write data	↑	Data bit	H	L

Note:

- (1) L is connected to V_{SS} and H is connected to V_{DDIO}
- (2) ↑ stands for rising edge of signal
- (3) SDIN is shifted into an 8-bit shift register on every rising edge of SCLK in the order of D7, D6, ... D0. The level of D/C# should be kept over the whole byte. The data byte in the shift register is written to the Graphic Display Data RAM (RAM)/Data Byte register or command Byte register according to D/C# pin.

File Name	Specification For HINK 2.13" EPD	Module Number	HINK-E0213A01
Version	A/0	Page Number	8 of 28

Figure 7-1 : Write procedure in 4-wire SPI

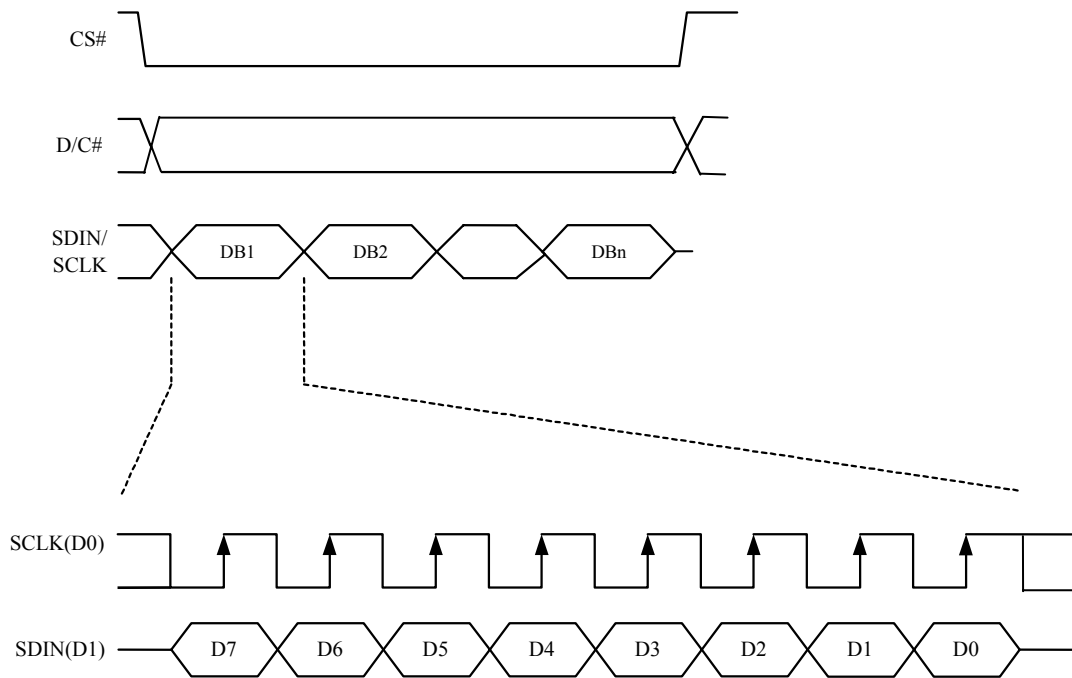

File Name	Specification For HINK 2.13" EPD	Module Number	HINK-E0213A01
Version	A/0	Page Number	9 of 28

7.3 MCU Serial Peripheral Interface (3-wire SPI)

The 3-wire SPI consists of serial clock SCLK, serial data SDIN and CS#. In SPI mode, D0 acts as SCLK, D1 acts as SDIN. The operation is similar to 4-wire SPI while D/C# pin is not used and it must be tied to LOW. The control pins status in 3-wire SPI is shown in Table 7-2.

In the write operation, a 9-bit data will be shifted into the shift register on every clock rising edge. The bit shifting sequence is D/C# bit, D7 bit, D6 bit to D0 bit. The first bit is D/C# bit which determines the following byte is command or data. When D/C# bit is 0, the following byte is command. When D/C# bit is 1, the following byte is data. Figure 7-2 shows the write procedure in 3-wire SPI

Table 7-2 : Control pins status of 3-wire SPI

Function	SCLK pin	SDIN pin	D/C# pin	CS# pin
Write command	↑	Command bit	Tie LOW	L
Write data	↑	Data bit	Tie LOW	L

Note:

- (1)L is connected to V_{SS} and H is connected to V_{DDIO}
- (2)↑ stands for rising edge of signal

Figure 7-2 : Write procedure in 3-wire SPI

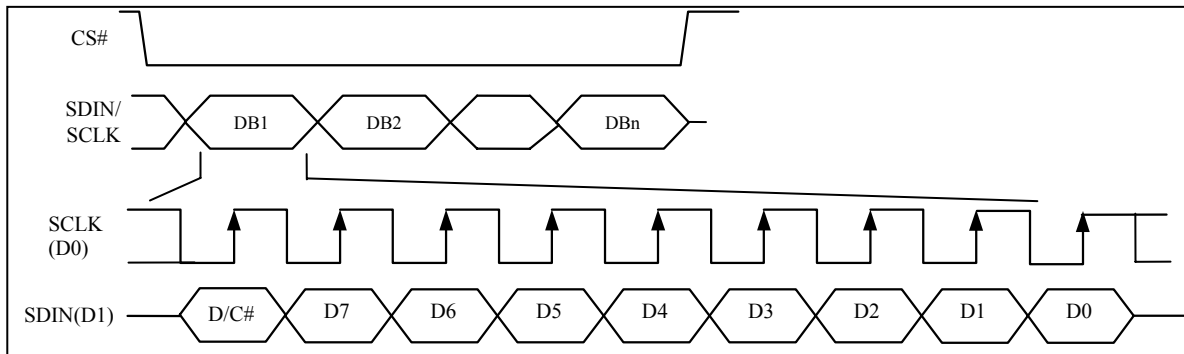

File Name	Specification For HINK 2.13" EPD	Module Number	HINK-E0213A01
Version	A/0	Page Number	10 of 28

8. Temperature Register Mapping

1. If the Temperature value MSByte bit D11 = 0, then

The temperature is positive and value (DegC) = + (Temperature value) / 16

2. If the Temperature value MSByte bit D11 = 1, then

The temperature is negative and value (DegC) = ~ (2's complement of Temperature value) / 16

12-bit binary (2's complement)	Hexadecimal Value	Decimal Value	Value [DegC]
0111 1111 0000	7F0	2032	127
0111 1110 1110	7EE	2030	126.875
0111 1110 0010	7E2	2018	126.125
0111 1101 0000	7D0	2000	125
0001 1001 0000	190	400	25
0000 0000 0010	002	2	0.125
0000 0000 0000	000	0	0
1111 1111 1110	FFE	-2	-0.125
1110 0111 0000	E70	-400	-25
1100 1001 0010	C92	-878	-54.875
1100 1001 0000	C90	-880	-55

9. Panel Break Detection

The panel break detection function is used to detect the breakage at panel edge. When the panel break detection command is issued, the panel break detection will be executed. During the detection period, BUSY output is at high level. BUSY output is at low level when the detection is completed. Then, user can issue the Status Bit Read command to check the status bit for the result of panel break.

File Name	Specification For HINK 2.13" EPD	Module Number	HINK-E0213A01
Version	A/0	Page Number	11 of 28

10. COMMAND TABLE

R/W#	D/C#	Hex	D7	D6	D5	D4	D3	D2	D1	D0	Command	Description									
0	0	01	0	0	0	0	0	0	0	1	Driver Output Control	Set the number of gate. Setting for 232 gates is: Set A[7:0] = F9h Set B[7:0] = 00h									
0	1	-	A7	A6	A5	A4	A3	A2	A1	A0											
0	1	-	0	0	0	0	0	0	B2	B1	B0	Gate Driving Voltage Control	Set Gate driving voltage. A[4:0] = 10h [POR], VGH at 22V B[3:0] = 0Ah [POR], VGL at -20V								
0	0	03	0	0	0	0	0	0	1	1											
0	1	-	0	0	0	0	A4	A3	A2	A1	A0	Source Driving voltage Control	Set Source output voltage. A[4:0] = 19h [POR], VSH/VSL at +/-15V								
0	1	-	0	0	0	0	0	B3	B2	B1	B0										
0	0	04	0	0	0	0	0	0	1	0	0	Deep Sleep Mode	<table border="1"> <tr> <th colspan="2">Deep Sleep mode Control</th> </tr> <tr> <th>A[0]</th> <th>Description</th> </tr> <tr> <td>0</td> <td>Normal Mode [POR]</td> </tr> <tr> <td>1</td> <td>Enter Deep Sleep Mode</td> </tr> </table>	Deep Sleep mode Control		A[0]	Description	0	Normal Mode [POR]	1	Enter Deep Sleep Mode
Deep Sleep mode Control																					
A[0]	Description																				
0	Normal Mode [POR]																				
1	Enter Deep Sleep Mode																				
0	1	-	0	0	0	0	A4	A3	A2	A1	A0										
0	0	10	0	0	0	1	0	0	0	0	Data Entry mode setting	Define data entry sequence. A [1:0] = ID[1:0] Address automatic increment / decrement setting The setting of incrementing or decrementing of the address counter can be made independently in each upper and lower bit of the address. 00 – Y decrement, X decrement, 01 – Y decrement, X increment, 10 – Y increment, X decrement, 11 – Y increment, X increment [POR] A[2] = AM Set the direction in which the address counter is updated automatically after data is written to the RAM. When AM= 0, the address counter is updated in the X direction. [POR] When AM = 1, the address counter is updated in the Y direction. Remark: More information in section 6.1									
0	1	-	0	0	0	0	0	0	A2	A1			A0								
0	0	12	0	0	0	1	0	0	1	0	SWRESET	It resets the commands and parameters to their S/W Reset default values except R10h-Deep Sleep Mode Note: RAM are unaffected by this command.									
0	0	1A	0	0	0	1	1	0	1	0	Temperature Sensor Control (Write to temperature register)	Write to temperature register. A[7:0] – MSByte 01111111[POR] B[7:0] – LSByte 11110000[POR] Remark: More information in section 6.2.									
0	1	-	A7	A6	A5	A4	A3	A2	A1	A0											
0	1	-	B7	B6	B5	B4	0	0	0	0	Master Activation	Activate Display Update Sequence. The Display Update Sequence Option is located at R22h User should not interrupt this operation to avoid corruption of panel images.									
0	0	20	0	0	1	0	0	0	0	0											



THINGWELL ELECTRONICS

TEL:+86-755-27435731 FAX:+86-755-27132381

http://www.lcdmaker.com

File Name		Specification For HINK 2.13" EPD									Module Number	HINK-E0213A01							
Version		A/0									Page Number	12 of 28							
R/W#	D/C#	Hex	D7	D6	D5	D4	D3	D2	D1	D0	Command	Description							
0	0	21	0	0	1	0	0	0	0	1	Display Update Control 1	Option for Display Update Bypass Option used for Pattern Display, which is used for display the RAM content into the Display OLD RAM Bypass option A [7] A[7] = 1: Enable bypass A[7] = 0: Disable bypass [POR] A[4] value will be used as New RAM for bypass. A[4] = 0 [POR] A[1:0] Initial Update Option - Source Control							
0	1	-	A7	A6	A5	A4	A3	A2	A1	A0									
		<table border="1"> <tr> <td>A[1:0]</td> <td>GSA</td> <td>GSB</td> </tr> <tr> <td>01[POR]</td> <td>GS0</td> <td>GS1</td> </tr> </table>			A[1:0]	GSA	GSB	01[POR]	GS0	GS1									
A[1:0]	GSA	GSB																	
01[POR]	GS0	GS1																	
0	0	22	0	0	1	0	0	0	1	0	Display Update Control 2	Display Update Sequence Option: Enable the stage for Master Activation							
0	1	-	A7	A6	A5	A4	A3	A2	A1	A0									
				Parameter (in Hex)															
		Enable Clock Signal, Then Enable Analog Then Load LUT Then INITIAL DISPLAY Then PATTERN DISPLAY Then Disable Analog Then Disable OSC		FF [POR]															
		<u>Setting for LUT from OTP</u> Enable Clock Signal, Then Enable Analog Then Load LUT Then PATTERN DISPLAY Then Disable Analog Then Disable OSC		D7															
		<u>Setting for LUT from MCU</u> Enable Clock Signal, Then Enable Analog Then PATTERN DISPLAY Then Disable Analog Then Disable OSC		C7															
0	0	23	0	0	1	0	0	0	1	1	Panel Break Detection	After this command is issued, panel break detection will start. The status can be checked by Command 2Fh. During detection, BUSY pad will output high. The command required CLKEN=1.							
0	0	24	0	0	1	0	0	1	0	0	Write RAM	After this command, data entries will be written into the RAM until another command is written. Address pointers will advance accordingly.							



THINGWELL ELECTRONICS

TEL:+86-755-27435731 FAX:+86-755-27132381

http://www.lcdmaker.com

File Name		Specification For HINK 2.13" EPD									Module Number	HINK-E0213A01																																																																
Version		A/0									Page Number	13 of 28																																																																
R/W#	D/C#	Hex	D7	D6	D5	D4	D3	D2	D1	D0	Command	Description																																																																
0	0	2C	0	0	1	0	1	0	1	1	Write VCOM register	Write VCOM register from MCU interface																																																																
0	1	-	A7	A6	A5	A4	A3	A2	A1	A0		<table border="1"> <thead> <tr> <th>A[7:0]</th> <th>VCOM (V)</th> <th>A[7:0]</th> <th>VCOM (V)</th> </tr> </thead> <tbody> <tr><td>0Fh</td><td>-0.2</td><td>5Ah</td><td>-1.7</td></tr> <tr><td>14h</td><td>-0.3</td><td>5Fh</td><td>-1.8</td></tr> <tr><td>19h</td><td>-0.4</td><td>64h</td><td>-1.9</td></tr> <tr><td>1Eh</td><td>-0.5</td><td>69h</td><td>-2</td></tr> <tr><td>23h</td><td>-0.6</td><td>6Eh</td><td>-2.1</td></tr> <tr><td>28h</td><td>-0.7</td><td>73h</td><td>-2.2</td></tr> <tr><td>2Dh</td><td>-0.8</td><td>78h</td><td>-2.3</td></tr> <tr><td>32h</td><td>-0.9</td><td>7Dh</td><td>-2.4</td></tr> <tr><td>37h</td><td>-1</td><td>82h</td><td>-2.5</td></tr> <tr><td>3Ch</td><td>-1.1</td><td>87h</td><td>-2.6</td></tr> <tr><td>41h</td><td>-1.2</td><td>8Ch</td><td>-2.7</td></tr> <tr><td>46h</td><td>-1.3</td><td>91h</td><td>-2.8</td></tr> <tr><td>4Bh</td><td>-1.4</td><td>96h</td><td>-2.9</td></tr> <tr><td>50h</td><td>-1.5</td><td>9Bh</td><td>-3</td></tr> <tr><td>55h</td><td>-1.6</td><td></td><td></td></tr> </tbody> </table>	A[7:0]	VCOM (V)	A[7:0]	VCOM (V)	0Fh	-0.2	5Ah	-1.7	14h	-0.3	5Fh	-1.8	19h	-0.4	64h	-1.9	1Eh	-0.5	69h	-2	23h	-0.6	6Eh	-2.1	28h	-0.7	73h	-2.2	2Dh	-0.8	78h	-2.3	32h	-0.9	7Dh	-2.4	37h	-1	82h	-2.5	3Ch	-1.1	87h	-2.6	41h	-1.2	8Ch	-2.7	46h	-1.3	91h	-2.8	4Bh	-1.4	96h	-2.9	50h	-1.5	9Bh	-3	55h	-1.6		
A[7:0]	VCOM (V)	A[7:0]	VCOM (V)																																																																									
0Fh	-0.2	5Ah	-1.7																																																																									
14h	-0.3	5Fh	-1.8																																																																									
19h	-0.4	64h	-1.9																																																																									
1Eh	-0.5	69h	-2																																																																									
23h	-0.6	6Eh	-2.1																																																																									
28h	-0.7	73h	-2.2																																																																									
2Dh	-0.8	78h	-2.3																																																																									
32h	-0.9	7Dh	-2.4																																																																									
37h	-1	82h	-2.5																																																																									
3Ch	-1.1	87h	-2.6																																																																									
41h	-1.2	8Ch	-2.7																																																																									
46h	-1.3	91h	-2.8																																																																									
4Bh	-1.4	96h	-2.9																																																																									
50h	-1.5	9Bh	-3																																																																									
55h	-1.6																																																																											
0	0	2F	0	0	1	0	1	0	0	1	Status Bit Read	A[3] : Panel-Break flag (POR=0) 0:Normal 1:Broken A[1:0] : Chip ID (POR=01)																																																																
1	1	-	0	0	0	0	A3	0	A1	A0																																																																		
0	0	32	0	0	1	1	0	0	1	0	Write LUT register	Write LUT register from MCU interface [30 bytes] (excluding the VSH/VSL and Dummy bit)																																																																
0	1	-	A7	A6	A5	A4	A3	A2	A1	A0																																																																		
0	1	-	B7	B6	B5	B4	B3	B2	B1	B0																																																																		
0	1	-	:	:	:	:	:	:	:	:																																																																		
0	1	-	:	:	:	:	:	:	:	:																																																																		
0	0	3A	0	0	1	1	1	0	1	0	Set dummy line period	Set A[7:0] = 06h																																																																
0	1	-	0	A6	A5	A4	A3	A2	A1	A0	Set Gate line width	Set A[3:0] = 0Bh																																																																
0	0	3B	0	0	1	1	1	0	1	1	Border Waveform Control	Select border waveform for VBD A[7] Follow Source at Initial Update Display A [7]=0: [POR] A [7]=1: Follow Source at Initial Update Display for VBD, A [6:0] setting are being overridden at Initial Display STAGE. A [6] Select GS Transition/ Fix Level for VBD A [6]=0: Select GS Transition A[3:0] for VBD A [6]=1: Select FIX level Setting A[5:4] for VBD [POR] A [5:4] Fix Level Setting for VBD																																																																
0	1	-	0	0	0	0	A3	A2	A1	A0																																																																		
0	0	3C	0	0	1	1	1	1	0	0																																																																		
0	1	-	A7	A6	A5	A4	0	0	A1	A0	<table border="1"> <thead> <tr> <th>A[5:4]</th> <th>VBD level</th> </tr> </thead> <tbody> <tr><td>00</td><td>VSS</td></tr> <tr><td>01</td><td>VSH</td></tr> <tr><td>10</td><td>VSL</td></tr> <tr><td>11[POR]</td><td>HiZ</td></tr> </tbody> </table> A [1:0] GS transition setting for VBD (Select waveform like data A[3:2] to data A[1:0]) <table border="1"> <thead> <tr> <th>A[1:0]</th> <th>GSC</th> <th>GSD</th> </tr> </thead> <tbody> <tr><td>01[POR]</td><td>GS0</td><td>GS1</td></tr> </tbody> </table>	A[5:4]	VBD level	00	VSS	01	VSH	10	VSL	11[POR]	HiZ	A[1:0]	GSC	GSD	01[POR]	GS0	GS1																																																	
A[5:4]	VBD level																																																																											
00	VSS																																																																											
01	VSH																																																																											
10	VSL																																																																											
11[POR]	HiZ																																																																											
A[1:0]	GSC	GSD																																																																										
01[POR]	GS0	GS1																																																																										



THINGWELL ELECTRONICS

TEL:+86-755-27435731 FAX:+86-755-27132381

<http://www.lcdmaker.com>

File Name		Specification For HINK 2.13" EPD									Module Number	HINK-E0213A01
Version		A/0									Page Number	14 of 28
R/W#	D/C#	Hex	D7	D6	D5	D4	D3	D2	D1	D0	Command	Description
0	0	44	0	1	0	0	0	1	0	0	Set RAM X - address Start / End position	Specify the start/end positions of the window address in the X direction by an address unit A[4:0]: X-Start, POR = 00h B[4:0]: X-End, POR = 12h
0	1	-	0	0	0	A4	A3	A2	A1	A0		
0	0	45	0	1	0	0	0	1	0	1	Set Ram Y-address Start / End position	Specify the start/end positions of the window address in the Y direction by an address unit A[7:0]: Y-Start, POR = 00h B[7:0]: Y-End, POR = F9h
0	1	-	A7	A6	A5	A4	A3	A2	A1	A0		
0	0	4E	0	1	0	0	1	1	1	0	Set RAM X - address counter	Make initial settings for the RAM X address in the address counter (AC) A[4:0] : POR is 00h
0	1	-	0	0	0	A4	A3	A2	A1	A0		
0	0	4F	0	1	0	0	1	1	1	1	Set RAM Y - address counter	Make initial settings for the RAM Y address in the address counter (AC) A[7:0] : POR is 00h
0	1	-	A7	A6	A5	A4	A3	A2	A1	A0		

File Name	Specification For HINK 2.13" EPD	Module Number	HINK-E0213A01
Version	A/0	Page Number	15 of 28

11. ABSOLUTE MAXIMUM RATING

Table 11-1: Maximum Ratings

Symbol	Parameter	Rating	Unit
V _{CI}	Logic supply voltage	-0.5 to +4.0	V
V _{IN}	Logic Input voltage	-0.5 to V _{DDIO} +0.5	V
V _{OUT}	Logic Output voltage	-0.5 to V _{DDIO} +0.5	V
T _{OPR}	Operation temperature range	0 to 60	°C
T _{STG}	Storage temperature range	-25 to 85	°C

Maximum ratings are those values beyond which damages to the device may occur. Functional operation should be restricted to the limits in the Electrical Characteristics tables or Pin Description section

This device contains circuitry to protect the inputs against damage due to high static voltages or electric fields; however, it is advised that normal precautions be taken to avoid application of any voltage higher than maximum rated voltages to this high impedance circuit. For proper operation it is recommended that V_{CI} be constrained to the range V_{SS} < V_{CI}. Reliability of operation is enhanced if unused input is connected to an appropriate logic voltage level (e.g., either V_{SS} or V_{DDIO}). Unused outputs must be left open. This device may be light sensitive. Caution should be taken to avoid exposure of this device to any light source during normal operation. This device is not radiation protected.



File Name	Specification For HINK 2.13" EPD	Module Number	HINK-E0213A01
Version	A/0	Page Number	16 of 28

12.DC CHARACTERISTICS

The following specifications apply for: VSS=0V, VCI=3.0V, T_{OPR}=25°C.

Table 12-1: DC Characteristics

Symbol	Parameter	Test Condition	Applicable pin	Min.	Typ.	Max.	Unit
V _{CI}	VCI operation voltage		VCI	2.4	3.0	3.7	V
V _{IH}	High level input voltage		D1 (SDIN), D0 (SCLK), CS#, D/C#, RES#, BS1	0.8V _{DDIO}			V
V _{IL}	Low level input voltage					0.2V _{DDIO}	V
V _{OH}	High level output voltage	IOH = -100uA	BUSY, TOUT1	0.9V _{DDIO}			V
V _{OL}	Low level output voltage	IOL = 100uA				0.1V _{DDIO}	V

File Name	Specification For HINK 2.13" EPD	Module Number	HINK-E0213A01
Version	A/0	Page Number	17 of 28

13. Serial Peripheral Interface Timing

13.1 Oscillator Frequency

The following specifications apply for: VSS=0V, VCI=2.4V to 3.7V, T_{OPR}=25°C

Symbol	Parameter	Min	Typ	Max	Unit
t _{cycle}	Clock Cycle Time	250	-	-	ns
t _{AS}	Address Setup Time	150	-	-	ns
t _{AH}	Address Hold Time	150	-	-	ns
t _{CSS}	Chip Select Setup Time	120	-	-	ns
t _{CSH}	Chip Select Hold Time	60	-	-	ns
t _{DSW}	Write Data Setup Time	50	-	-	ns
t _{DHW}	Write Data Hold Time	15	-	-	ns
t _{CLKL}	Clock Low Time	100	-	-	ns
t _{CLKH}	Clock High Time	100	-	-	ns
t _R	Rise Time [20% ~ 80%]	-	-	15	ns
t _F	Fall Time [20% ~ 80%]	-	-	15	ns

Figure 13-1 : Serial peripheral interface characteristics

13.2 Interface Timing

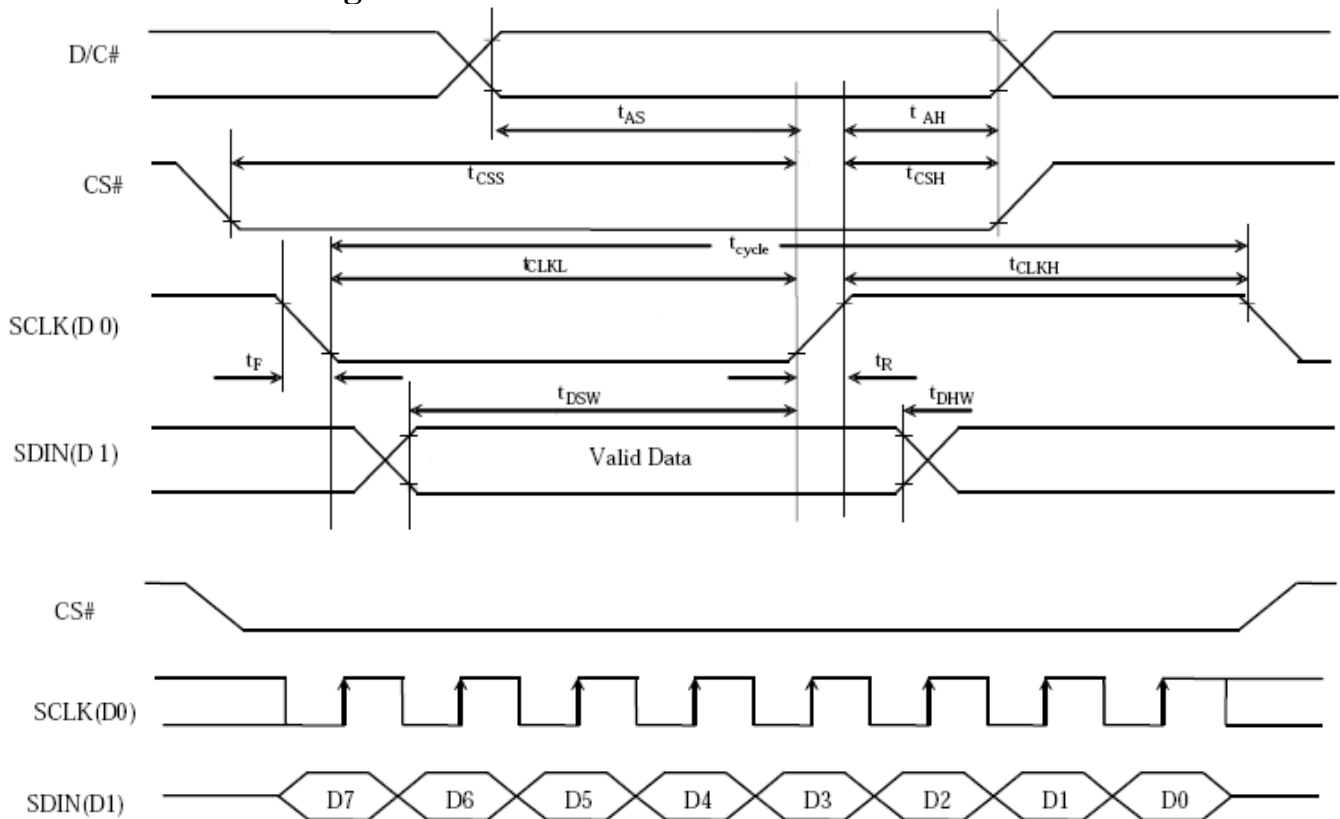

File Name	Specification For HINK 2.13" EPD	Module Number	HINK-E0213A01
Version	A/0	Page Number	18 of 28

13.3 Power Consumption

Parameter	Symbol	Conditions	TYP	Max	Unit	Remark
Panel power consumption during update	-	-	26.4	40	mW	-
Power consumption in standby mode	-	-	-	0.017	mW	-

14 Reference Circuit

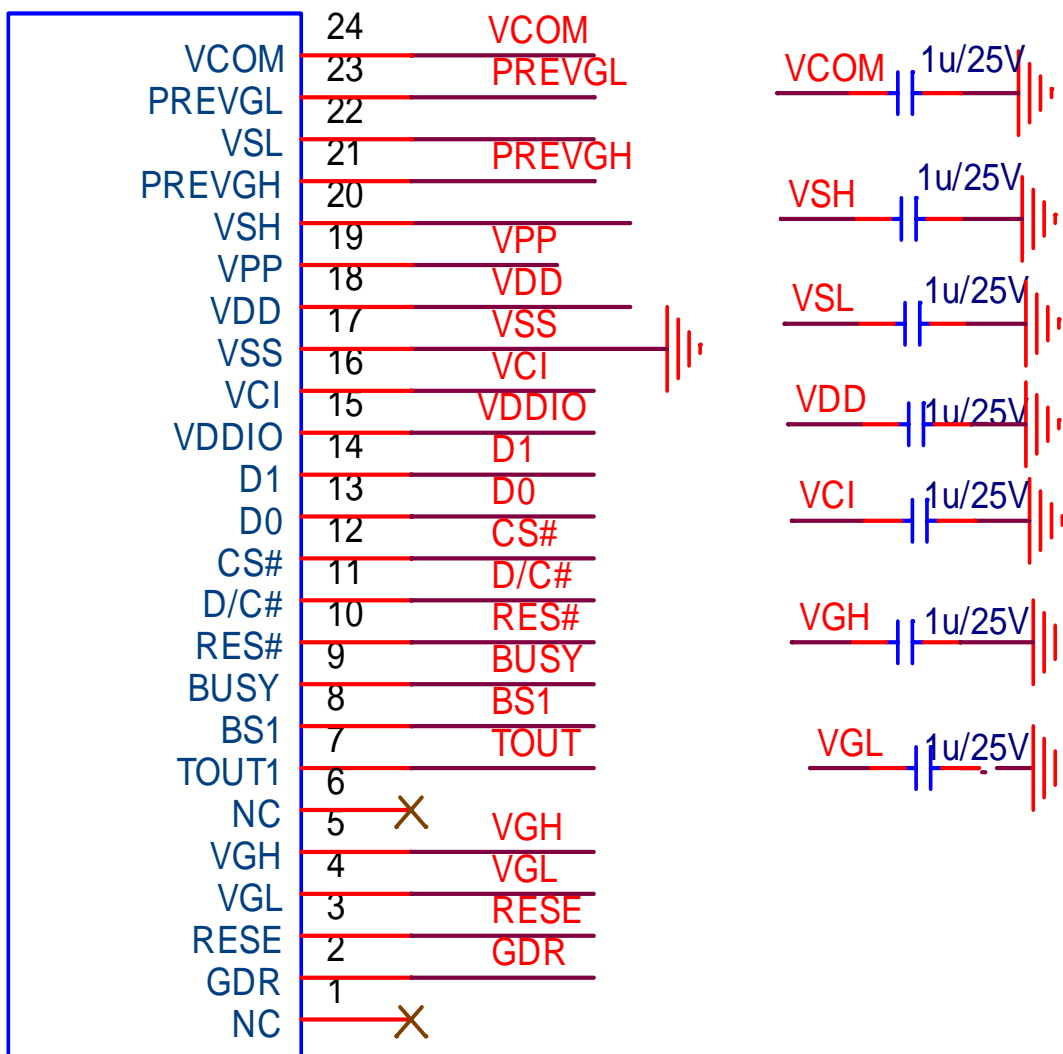

Figure . 14-1

File Name	Specification For HINK 2.13" EPD	Module Number	HINK-E0213A01
Version	A/0	Page Number	19 of 28

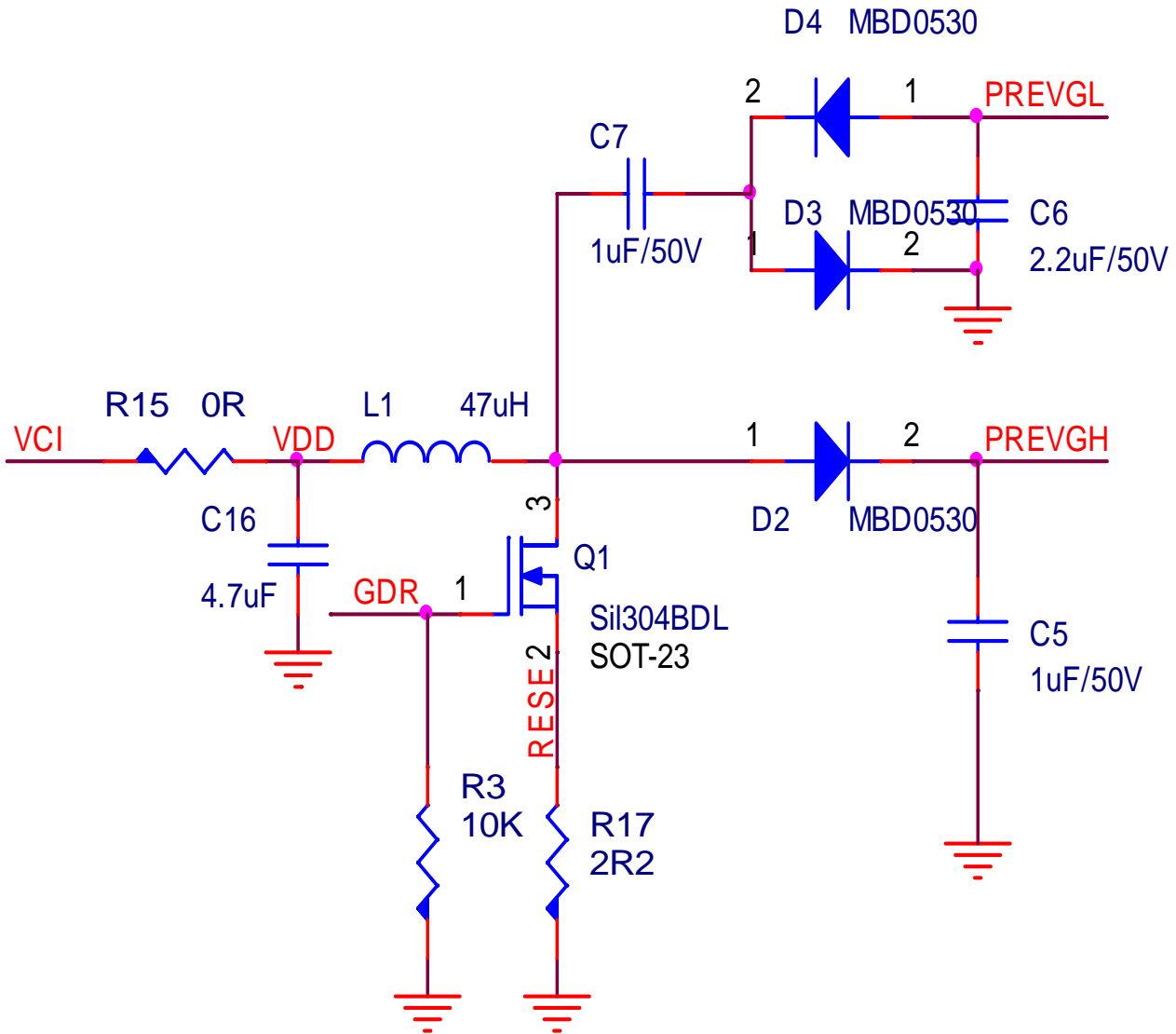
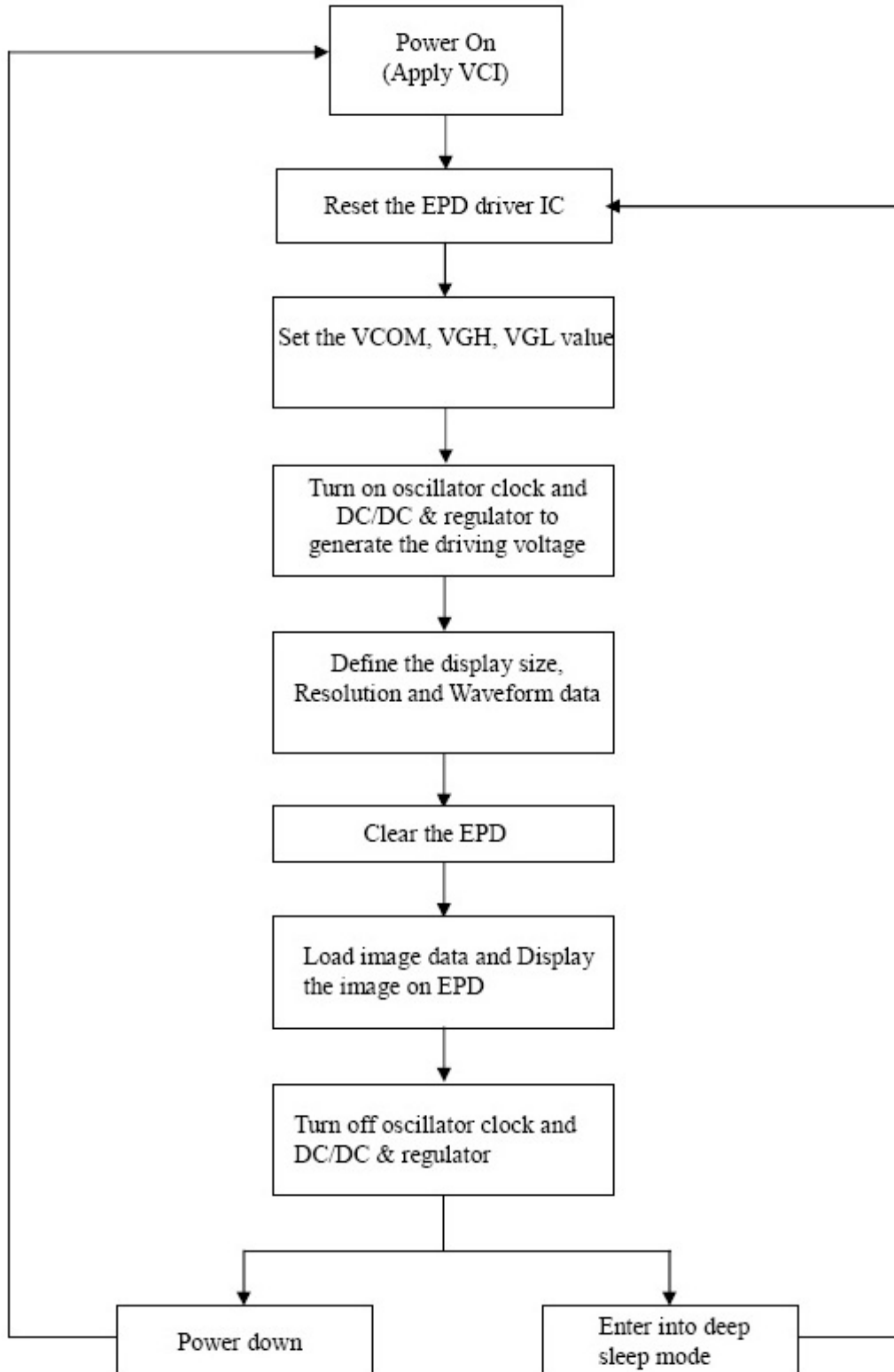

Figure . 14-3

File Name	Specification For HINK 2.13" EPD	Module Number	HINK-E0213A01
Version	A/0	Page Number	20 of 28

15. Typical Operating Sequence



File Name	Specification For HINK 2.13" EPD	Module Number	HINK-E0213A01
Version	A/0	Page Number	21 of 28

16. Optical characteristics

16.1 Specifications

Measurements are made with that the illumination is under an angle of 45 degrees, the detection is perpendicular unless otherwise specified.

T=25°C

SYMBOL	PARAMETER	CONDITIONS	MIN	TYPE	MAX	UNIT	Note
R	Reflectance	White	34	43	-	%	Note 17-1
Gn	2Grey Level	-	-	DS+(WS-DS) x n (m-1)	-	L*	-
CR	Contrast Ratio	indoor	-	10	-	-	-
T _{update}	Update time	25°C	-	600	-	ms	-
Panel's life		0°C~60°C		1000000 times or 5 years			Note 17-2

WS : White state, DS : Dark state

Gray state from Dark to White : DS、WS

m : 2

Note 17-1 : Luminance meter : Eye - One Pro Spectrophotometer

Note 17-2 :When work in temperature below 0 degree or above 40 degree , we do not recommend because the panel's life will not be guaranteed

16.2 Definition of contrast ratio

The contrast ratio (CR) is the ratio between the reflectance in a full white area (R1) and the reflectance in a dark area (Rd) :

R1: white reflectance

Rd: dark reflectance

$$CR = R1/Rd$$

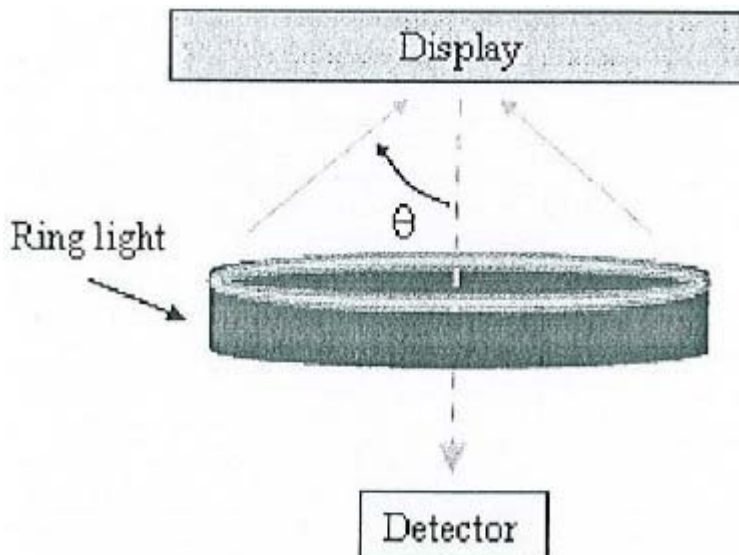

File Name	Specification For HINK 2.13" EPD	Module Number	HINK-E0213A01
Version	A/0	Page Number	22 of 28

16.3 Reflection Ratio

The reflection ratio is expressed as :

$$R = \text{Reflectance Factor}_{\text{white board}} \times (L_{\text{center}} / L_{\text{white board}})$$

L_{center} is the luminance measured at center in a white area ($R=G=B=1$) . $L_{\text{white board}}$ is the luminance of a standard white board . Both are measured with equivalent illumination source . The viewing angle shall be no more than 2 degrees .

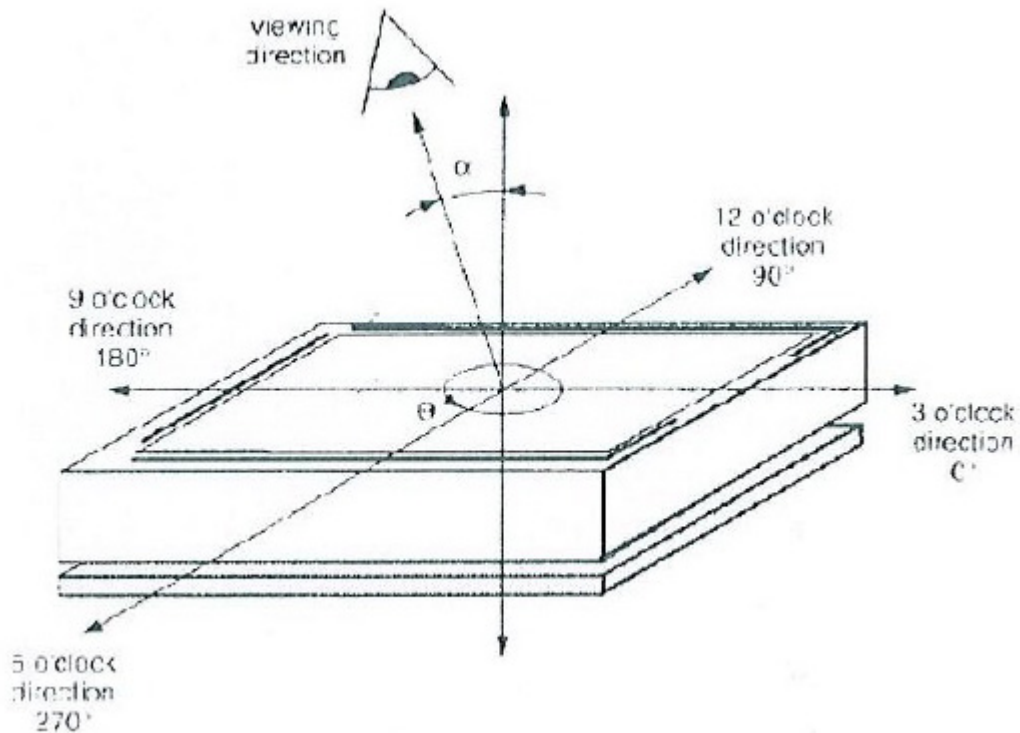

16.4 Bi-stability

The Bi-stability standard as follows:

Bi-stability	Result		
		AVG	MAX
24 hours Luminance drift	White state ΔL^*	-	2
	Black state ΔL^*	-	2



File Name	Specification For HINK 2.13" EPD	Module Number	HINK-E0213A01
Version	A/0	Page Number	23 of 28

17. HANDLING, SAFETY AND ENVIRONMENTAL REQUIREMENTS

WARNING

The display glass may break when it is dropped or bumped on a hard surface . Handle with care. Should the display break, do not touch the electrophoretic material . In case of contact with electrophoretic material , wash with water and soap.

CAUTION

The display module should not be exposed to harmful gases , such as acid and alkali gases , which corrode electronic components.

Disassembling the display module can cause permanent damage and invalidate the warranty agreements.

Observe general precautions that are common to handling delicate electronic components . The glass can break and front surfaces can easily be damaged . Moreover the display is sensitive to static electricity and other rough environmental conditions.

Data sheet status

Product specification	The data sheet contains final product specifications.
-----------------------	---

Limiting values

Limiting values given are in accordance with the Absolute Maximum Rating System (IEC 134). Stress above one or more of the limiting values may cause permanent damage to the device. These are stress ratings only and operation of the device at these or any other conditions above those given in the Characteristics sections of the specification is not implied . Exposure to limiting values for extended periods may affect device reliability.

Application information

Where application information is given , it is advisory and does not form part of the specification.

Product Environmental certification

ROHS

File Name	Specification For HINK 2.13" EPD	Module Number	HINK-E0213A01
Version	A/0	Page Number	24 of 28

18. Reliability test

	TEST	CONDITION	METHOD	REMARK
1	High-Temperature Operation	T = 50°C,30% for 240 hrs	IEC 60 068-2-2Bp	
2	Low-Temperature Operation	T = 0°Cfor 240 hrs	IEC 60 068-2-2Ab	
3	High-Temperature Storage	T = +70°C23% for 240 hrs Test in white pattern	IEC 60 068-2-2Bp	
4	Low-Temperature Storage	T = -25°Cfor 240 hrs Test in white pattern	IEC 60 068-2-2Ab	
5	High Temperature, High-Humidity Operation	T=+40°C RH=90%for 240hrs	IEC 60 068-2-3CA	
6	High Temperature, High-Humidity Storage	T=+60°C RH=80%for 240hrs Test in white pattern	IEC 60 068-2-3CA	
7	Temperature Cycle	[-25°C30mins]→ [+70°C30mins] ,1000cycles Test in white pattern	IEC 60 068-2-14NB	

Actual EMC level to be measured on customer application.

Note : The protective film must be removed before temperature test.

File Name	Specification For HINK 2.13" EPD	Module Number	HINK-E0213A01
Version	A/0	Page Number	25 of 28

19. Block Diagram

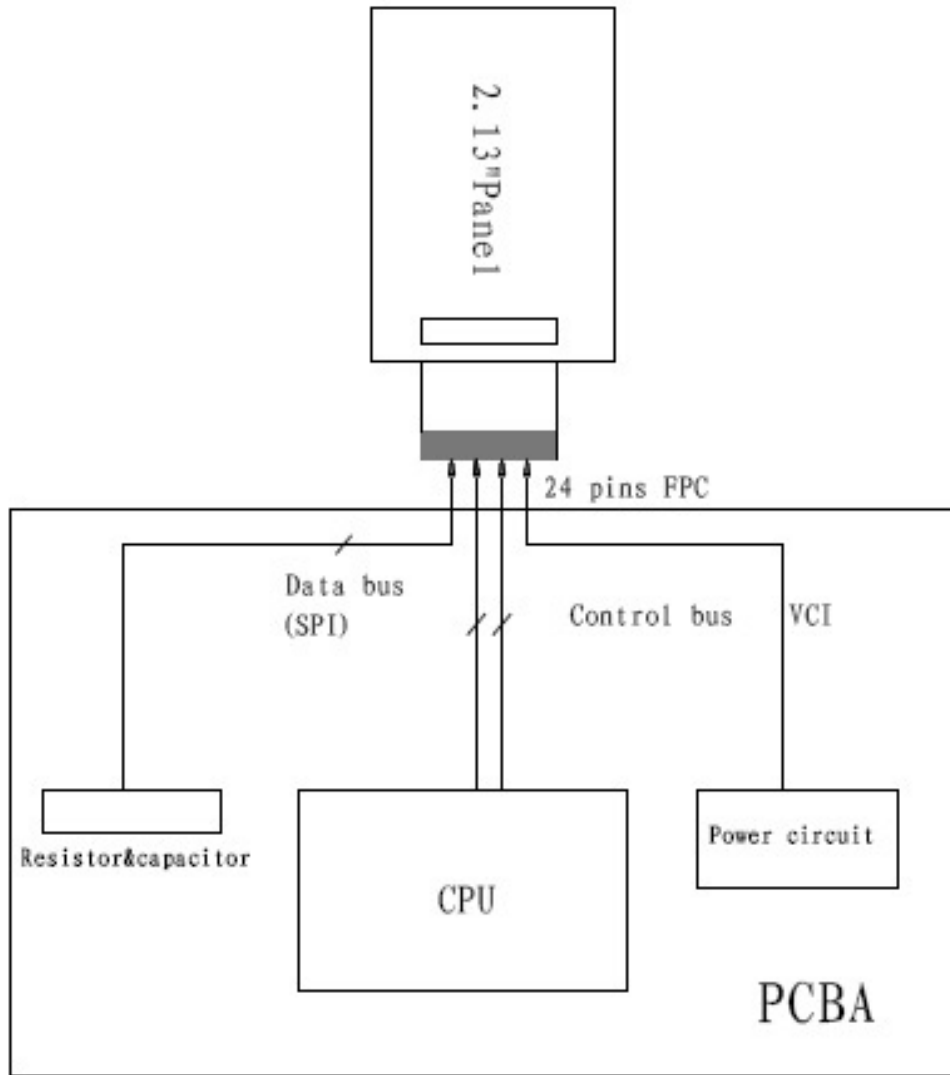

File Name	Specification For HINK 2.13" EPD	Module Number	HINK-E0213A01
Version	A/0	Page Number	26 of 28

20. Point and line standard

Shipment Inseption Standard						
Equipment: Electrical test fixture, Point gauge						
Outline demension: 36.7(H)×79.0(V) ×1.05(D)				Unit: mm		
Environment	Temperature	Humidity	Illuminance	Distance	Time	Angle
	19℃~25℃	40%~55%RH	700~1000Lux	200~400 mm	35Sec	
appearance standard	Defet type	Inspection	Standard		Part-A	
	dead/ switch point (point overproof)	Electric Display	D≤0.2 mm		Ignore	
			0.2 mm < D ≤ 0.4 mm		N≤3	
			D > 0.4 mm		Not Allow	
	2.line (no switch)	Electric Display	L≤0.5mm, to point to determine			
			L≤4W, to point to determine			
	3.line (Switching line)	Electric Display	Ignore in gray scale viewing In Blak&white viewing Follow Non-Switching Criteria			
	4.Display unwork	Electric Display	Not Allow			
	5.Display error	Electric Display	Not Allow			
	6.warping	Vsual	T<0.5mm, Ignore;			
	7.Protector hurt	Vsual	L≤2 mm, W≤0.05 mm, Ignore;			
			0.05mm < W ≤ 0.1mm, L≤4mm, N≤2			
			L > 4 mm, W > 0.1 mm, Not Allow;			
8.PS Bubble	Vsual	D≤0.20mm, Ignore;				
		0.2mm≤D<0.35mm & N≤2				
		D > 0.35 mm, Not Allow;				
9.Packing	Vsual	cannot be dirty and breakdown;must be marked and identified				
Remark	1.Cannot be defect&failure cause by appearence defect;					
	2.Cannot be larger size cause by appearence defect;					

File Name	Specification For HINK 2.13" EPD	Module Number	HINK-E0213A01
Version	A/0	Page Number	27 of 28

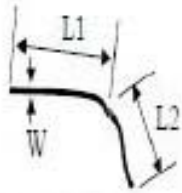

$$L = L1 + L2$$

Line Defect

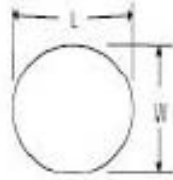

$$D = (L + W) / 2$$

Spot Defect

L=long W=wide D=point size

Edition	Content	Date
1	New edition	Sep.26.2014

File Name	Specification For HINK 2.13" EPD	Module Number	HINK-E0213A01
Version	A/0	Page Number	28 of 28

21. Packing

包装文件

文件编号:

	产品型号	HINK-E0213A01-A3	编制日期	2015. 8. 16	版本	A0	页码	2-1
--	------	------------------	------	-------------	----	----	----	-----

一、外包装方式: 纸箱

外箱型号	HINK-E0213A01-ZX-A0
外箱尺寸	482*400*170
产品总数量	432 PCS

产品图纸

二、内包装方式: 吸塑
单位: mm

吸塑盒	433*355*12	13 pcs
防静电铝箔袋	700*530*0.1	1 pcs
吸塑盘珍珠棉垫	370.00*74.55*2	48 pcs
天地珍珠棉垫	435*350*10	2 pcs
左右珍珠棉垫	355*145*10	2 pcs
前后珍珠棉垫	440*145*10	2 pcs
纸板	375*455*5	2 pcs
产品数量/盒	36 pcs	
盘数/扎	12+1 Sheets	
扎数/箱	1	

步骤一:
材料: 吸塑, 吸塑盘珍珠棉垫
产品如图示将显示面朝上方向一致放在吸塑盒里面, 每盒里面再放上吸防静电铝箔袋珍珠棉垫。

步骤二,
1), 吸塑盒与吸塑盒之间需要旋转180度摆放,
2), 每扎放置12层产品, 共 32*12=384片产品。
3), 表层交叉放置1个空吸塑盒

步骤三,
1), 在每扎吸塑里面放两袋子干燥剂再用胶纸封紧,
2), 将封好的吸塑放进铝箔袋中
3), 对铝箔袋进行热压封口

步骤四,
1), 先将纸板放入纸箱底部再放上天地珍珠棉垫, 最后把左右及前后珍珠棉垫放入纸箱的左右前后。
2), 将封好的产品放入纸箱里面
3), 再装好产品纸箱最上面放上天地珍珠棉垫, 再放上纸板。

步骤五,
1), 用胶纸将装有产品的纸箱封好。
2), 在外箱的外面贴上出货标签, 标签不可覆盖安全运输标志及无铅标识。

The Netherlands



Elektrostraat 17
NL-7483 PG Haaksbergen

T: +31 (0)53 573 33 33
F: +31 (0)53 573 33 30
E: nl@texim-europe.com

Belgium



Zuiderlaan 14 bus 10
B-1731 Zellik

T: +32 (0)2 462 01 00
F: +32 (0)2 462 01 25
E: belgium@texim-europe.com

UK & Ireland



St. Mary's House, Church Lane
Carlton Le Moorland
Lincoln LN5 9HS

T: +44 (0)1522 789 555
F: +44 (0)845 299 22 26
E: uk@texim-europe.com

Germany North



Bahnhofstrasse 92
D-25451 Quickborn

T: +49 (0)4106 627 07-0
F: +49 (0)4106 627 07-20
E: germany@texim-europe.com

Germany South



Martin-Kollar-Strasse 9
D-81829 München

T: +49 (0)89 436 086-0
F: +49 (0)89 436 086-19
E: germany@texim-europe.com

Austria



Warwitzstrasse 9
A-5020 Salzburg

T: +43 (0)662 216 026
F: +43 (0)662 216 026-66
E: austria@texim-europe.com

Nordic region



Sdr. Jagtvej 12
DK-2970 Hørsholm

T: +45 88 20 26 30
F: +45 88 20 26 39
E: nordic@texim-europe.com

General information



info@texim-europe.com
www.texim-europe.com